

T H E
"RADIO"
H A N D B O O K

THIS EDITION, CLOTH BOUND, \$1.60 IN CONTINENTAL U.S.A.; ELSEWHERE \$1.85

OTHER PUBLICATIONS

By the Editors of "Radio"

"RADIO"

RADIO TECHNICAL DIGEST

"RADIO" AMATEUR NEWCOMER'S HANDBOOK

"RADIO" NOISE REDUCTION HANDBOOK

"RADIO" ULTRA-HIGH FREQUENCY HANDBOOK

(SEE ADVERTISING SECTION FOR DETAILS)

T H E
" R A D I O "
H A N D B O O K

SEVENTH EDITION

ISSUED ANNUALLY
BY THE EDITORS OF "RADIO"

W. W. SMITH
EDITORIAL DIRECTOR

RAY L. DAWLEY
EDITOR

E. H. Conklin
K. V. R. Lansingh

W. E. McNatt
A. McMullen
J. H. Rothman

Leigh Norton
B. A. Ontiveros

PUBLISHED AND DISTRIBUTED BY
EDITORS AND ENGINEERS
LIMITED

1300 KENWOOD ROAD, SANTA BARBARA, CALIFORNIA

FIRST PRINTING, OCTOBER, 1940

PUBLISHED ANNUALLY

COPYRIGHT, 1940, BY

**EDITORS AND ENGINEERS
LIMITED**

1300 KENWOOD ROAD, SANTA BARBARA, CALIFORNIA

COPYRIGHT SECURED UNDER PAN-AMERICAN CONVENTION

ALL TRANSLATION RIGHTS RESERVED

THE "RADIO" HANDBOOK

Table of Contents

Foreword	6
Chapter	
1. Introduction to Amateur Radio.....	7
2. Introductory Electricity and Fundamental Radio Theory.....	19
3. Vacuum Tube Theory.....	50
4. Radio Receiver Theory.....	66
5. Radio Receiver Tube Characteristics.....	95
6. Radio Receiver Construction.....	129
7. Transmitter Theory.....	150
8. Radiotelephony Theory.....	184
9. Frequency Modulation.....	214
10. Transmitting Tubes.....	224
11. Transmitter Design.....	240
12. Exciters and Low Powered Transmitters.....	249
13. Medium and High Powered Amplifiers.....	262
14. Speech and Modulation Equipment.....	271
15. Power Supplies.....	291
16. Transmitter Construction.....	313
17. U.H.F. Communication.....	339
18. U.H.F. Receivers and Transceivers.....	350
19. U.H.F. Transmitters.....	368
20. Antennas	393
21. U.H.F. Antennas.....	447
22. Test and Measuring Equipment.....	452
23. Workshop Practice.....	482
24. Broadcast Interference.....	491
25. Radio Therapy.....	498
26. Radio Mathematics and Calculations.....	502

Appendix—Buyer's Guide—Index

WRITTEN BY THE EDITORS OF "RADIO"

THE "RADIO" HANDBOOK

Foreword

The Editors of RADIO have unquestionably become in recent years the outstanding group in radio not affiliated with a definite commercial interest. They are all practical radio engineers and active amateurs of many years' experience. They are the source of the reputation and prestige of RADIO, envied by publications of greater circulation.

Starting several years ago with an extensive set of "notes" compiled for their own use, the Editors of RADIO have developed the present "RADIO" HANDBOOK, which is now in its seventh edition. Each edition is thoroughly revised, not merely brought up to date. To keep up with rapid developments in commercial equipment, the great majority of items shown in the constructional pages are newly built for each edition. Though a few outstanding items were selected from other publications by the same publishers, the greater portion are built especially for this handbook. All have been tried in actual practice.

Taken all in all, no effort has been spared in an attempt to compile the most comprehensive book on the subject, both as a reference for those with wide knowledge of the field and as a practical text for those of limited knowledge and means.

In closing, we wish to thank those whose year-after-year purchases have indicated their approval of such an unusual policy. This policy has only been possible, however, with the additional cooperation of our advertisers. In similar technical fields texts such as this sell from \$5.00 upwards; whatever value this book may have for you over its purchase price is a gift to you from our advertisers. We hope that you will reciprocate by using their products when suited to the job at hand.

SANTA BARBARA, CALIFORNIA
October, 1940

THE PUBLISHERS

The Editors of RADIO in preparing this work have not only drawn upon their own knowledge and extensive experience, but also have drawn upon nearly the whole current field of radio literature, wherefore it is impossible to give due acknowledgment to all whose work has been consulted to some extent. We wish to acknowledge particularly the kind permission of the RCA Manufacturing Co., Inc., to use certain of the formulas in the theoretical pages, as well as extensive data and specifications on vacuum tubes.

CHAPTER ONE

Introduction to Amateur Radio

Although much of the information in this handbook is of interest to engineers, students, sound men, experimenters, servicemen, and commercial operators, undoubtedly the largest single group having use for the material herein is composed of radio amateurs. Hence, to them the major portion of this book is dedicated; the material is written from their point of view.

Naturally an amateur finds much use for a text that caters primarily to him. But the person interested in *becoming* an amateur has still greater need for such a book. Hence this book is not only dedicated primarily to the radio amateur, but is so written that previous experience with amateur radio or previous knowledge of amateur radio is not required for comprehension of its contents.

Radio Amateurs. While the definition of "amateur" would seem to include shortwave listeners as radio amateurs, the term ordinarily is used to indicate specifically those radio hobbyists possessing a government license and amateur call letters.

More than 50,000 licensed amateurs in the U.S.A. are actively engaged in this field for purposes of experimentation, adventure, and personal enjoyment. It is interesting to consider what there is about amateur radio that captures and holds the interest of so many people throughout the world and from all walks of life, for unquestionably there is something about it which generates a lasting interest in its varied problems and activities.

Many famous men, holding high-salaried positions of importance in the radio industry today, got their start in the radio business by discovering an interest in amateur radio. A large number of these executives and engineers continue to enjoy amateur radio as an avocation even though commercially engaged in the radio industry, so strong is the fascination afforded by this hobby.

Technical Achievement. Although "Hamming" generally is considered to be "only a hobby" by the general public, its history contains countless incidents of technical achievements by its members which have served to improve radio communication and broadcasting. Many of the more important advancements in the art of radio communication can be chalked up to the ingenuity of radio amateurs. Experiments conducted by inquisitive amateurs have led to important developments in the fields of electronics, television, radio therapy, sound pictures, and public address, as well as in radio communication and broadcasting.

Fellowship. Amateurs are a most hospitable and fraternal lot. Their common interest makes them "brothers under the skin" and binds them together as closely as would membership in any college fraternity, lodge, or club. When visiting a strange town an amateur naturally first will look up any friends in that town he has made over the air. But even if he is unknown to any amateurs in that town, his amateur call is an "open sesame." The local amateurs will hang out the welcome sign and greet him like a long lost brother.

It is not unusual for an amateur to boast a large circle of friends, scattered throughout the country, with whom he chats nightly while seated comfortably at home. He gets to know these people intimately, many of whom he will never meet personally. Frequently he is of service to them, and they to him, in delivering messages to other people.

Amateur radio clubs have been formed in nearly all of the principal cities in the United States. The first thing a newcomer should do is to attend one of these club meetings and let the members know that he is interested in joining the ranks of radio amateurs. The veteran amateurs will be glad to lend a hand

with any difficult problems you might encounter and often can give invaluable advice as a result of their own experience. Also, you will be introduced to others who have recently taken an interest in amateur radio, and will have someone with whom to study. A "study companion" is especially helpful when it comes to learning the code.

Public Service. The radio amateur, or "ham," often renders public service. When hurricane, flood, earthquake, or heavy ice wrecks havoc with telephone and telegraph lines and the mails, the newspapers invariably follow with an account of how aid was summoned to the devastated area and communication maintained with the outside world largely through the efforts of radio amateurs. Radio amateurs are justly proud of their record of heroism and service in times of emergency. Many expeditions to remote places have kept in touch with home and business by "working" amateurs on the short waves.

A Diversified Hobby. Amateur radio is a hobby with several phases. There are those who revel in long-distance contacts with amateurs in far-off lands and try to excel in number of distant stations "worked." These enthusiasts are called "dx" men. Unfortunately this activity has been curtailed by the war.

Others make a specialty of relaying messages free of charge for people in their communities, and these fellows often perform meritorious services. Still others prefer not to specialize, but simply to "chew the rag" with any other hams who happen to be on the air.

Then, there are the experimenters, indefatigable individuals always striving for perfection. They are everlastingly building up and tearing down transmitters and receivers, deriving as much enjoyment from the construction or improvement of equipment as from its operation on the air. Whichever phase most strongly captures your fancy, you will find amateur radio an absorbing hobby.

Before you may join the others on the air, however, you must be licensed by the government to operate a transmitting station; so your first task will be to acquire sufficient knowledge to pass the test. Those who attempt to operate (on the air) *any kind of transmitting* equipment without a license are liable to a fine and imprisonment.

How to Obtain Your License

To obtain an amateur transmitting license from the U.S. government, you must be a citizen of the U.S.A., master the code, know how amateur transmitters and receivers work and how they must be adjusted, and be familiar with regulations pertaining to amateur operators and stations. An application blank for amateur radio operator and station license can be obtained from your district office of the Federal Communications Commission. A list of district offices is printed in chapter 27.

When you have filled out this application properly, sworn to it before a notary public, and returned it to the district office, the inspector in charge will notify you of the time and place of your examination. There is no charge for an amateur operator and sta-



Figure 1.

The signals of de luxe amateur station KAILZ in Manila, Philippine Islands, are heard consistently throughout the world. Most amateur stations, especially those outside the U.S.A., are not nearly so elaborate.

tion license and there are no age limits.

It is necessary that your station not be located on premises under the *control* of an alien. Remember this when determining the proposed site of your transmitter and filling out the application blanks. If you rent from an alien, the premises are under your "control" and you have nothing to worry about. However, if you merely "board" instead of rent, that does not put the premises under your control.

The examination will consist of a practical code test and a written theoretical examination. The written examination usually includes ten questions, some of which are in several parts. The questions are of the "multiple answer" type, and the applicant has to pick the correct answer from several listed with each question. An extensive list of questions, typical of those asked in the examination, is given in the RADIO AMATEUR NEWCOMER. In the code test you will be required to send and receive messages in plain language, including figures and punctuation marks, at a speed of 13 words per minute (5 characters to the word) for a period of one minute, without mistakes.

If you pass both the code and written tests successfully, you will later receive a class B license from the Commission's offices in Washington. This license, when signed by you, becomes valid. It is a combination operator and station license, one being printed on the reverse side of the other.

The station license portion will bear your call letters, which will be made up of the initial letter W or K, your call area numeral

(to determine your prefix and in which U.S. call area you are residing, refer to figure 4), and two or three additional letters, such as W9ZZZ. The prefix W is assigned to all amateur stations within the *continental* U.S.A. and KA to KH to territories and possessions.

Do not confuse the *call areas* (1 to 9) with the *U.S. Radio Districts* (1 to 22). It is rather confusing to the newcomer because amateurs commonly refer to call areas as districts and indicate a station in, for example, the ninth call area as a "ninth district station."

The class B operator license will authorize you to operate c.w. radiotelegraph transmitters (any licensed amateur transmitter, not just your own) in any amateur band or radiophone transmitters in the 160-, 10-, 5-, 2½-, 1¼-, and ¾-meter bands. You will not be entitled to operate phone in the select 80- and 20-meter bands until you have held your class B license for at least one year and have passed an examination for the class A license.

The Class C License. If you live more than 125 miles air-line distance, from the nearest examining point maintained by the Federal Communications Commission, you may apply for a class C license, the examination for which is given by mail. Other persons allowed to apply for the class C license include (1) applicants who can show a certificate from a reputable physician stating that the applicant is unable because of protracted disability to appear for examination, (2) persons stationed at a camp of the Civilian Conservation Corps, and (3) persons who

Figure 2.
Amateur radiophone station
W9NLP of Chicago, a typical
high power installation using
"commercial" type construction.

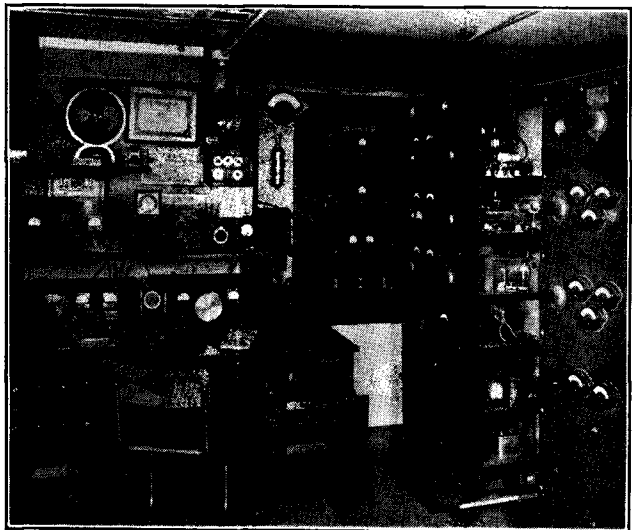

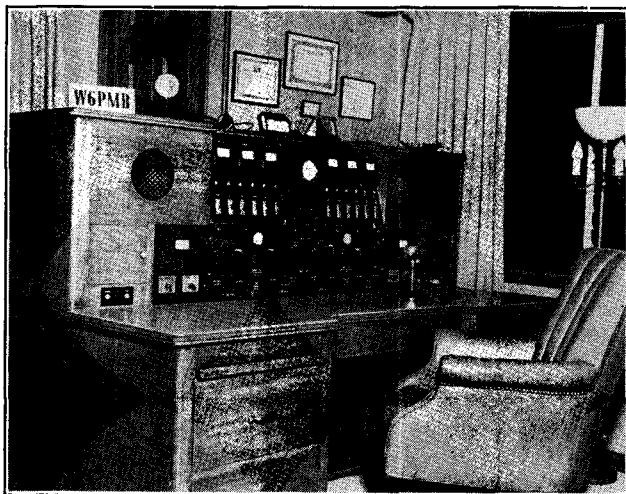

Figure 3.
The receiving position of the preprocessing installation at W6PMB shows that amateur equipment may be made to blend unobtrusively with home furnishings.

are in the *regular* military or naval service of the United States at a military post or naval station.

A licensed radiotelegraph operator (other than an amateur operator who himself holds only a class C license) or a regularly employed government radiotelegraph operator must sign the class C applicant's blank in the presence of a notary public, attesting to the applicant's ability to send and receive the continental Morse code at the required speed of 13 words per minute. Do *not* send for class C blanks containing the examinations and questions until you feel you are *ready to take your examination*, as you are not supposed to hold them indefinitely after receiving them.

Holders of class C licenses *may* be required by the Commission to appear at an examining point for a supervised written examination and practical code test at any time during the term of their licenses. This is seldom done except where the Commission has reason to suspect that the applicant would have difficulty in passing the class B examination. For instance, an amateur holding a class C ticket who regularly is heard on the air with a bad note or modulation, or is heard sending always at 8 or 9 words a minute, or repeatedly requests QRS, should not be at all surprised to receive a notice to appear. The class C license will be cancelled if the holder does not appear for examination when called or if he fails to pass when he does appear.

The privileges granted by the class C license are identical with those of the class B.

Your operator and station licenses will run concurrently, both expiring together three

years from the date of issuance stated on the face of the license. Both may be renewed without examination if an application is filed at least 60 days prior to the indicated date of expiration and the applicant offers proof that he has communicated via amateur radio with three other amateur stations during the three-month period directly preceding the date of application for renewal.

You may obtain just an operator license (without the station license) if you desire; this will permit you to operate any licensed amateur station. The "station" side of the license will be left blank and you will have no call letters assigned to you. It is not possible to apply for or obtain a station license singly unless you already have an operator license.

Heavy penalties are provided for obtaining an amateur license by fraudulent means, such as by impersonating another person in an examination, copying from notes, books or the like, or misrepresenting the fact of one's U.S. citizenship. Applicants who fail to pass the examination can take it again after two months have passed from the time of the last examination.

There are so many special instances that may arise that no attempt will be made to cover every possible contingency pertaining to the application for and privileges accorded by an amateur license. If you have a special question regarding some point not covered in this book or which is not clear to you, write to the Inspector-in-Charge of your radio district. Don't guess at the proper interpretation or take somebody else's word for it; you may get in trouble.

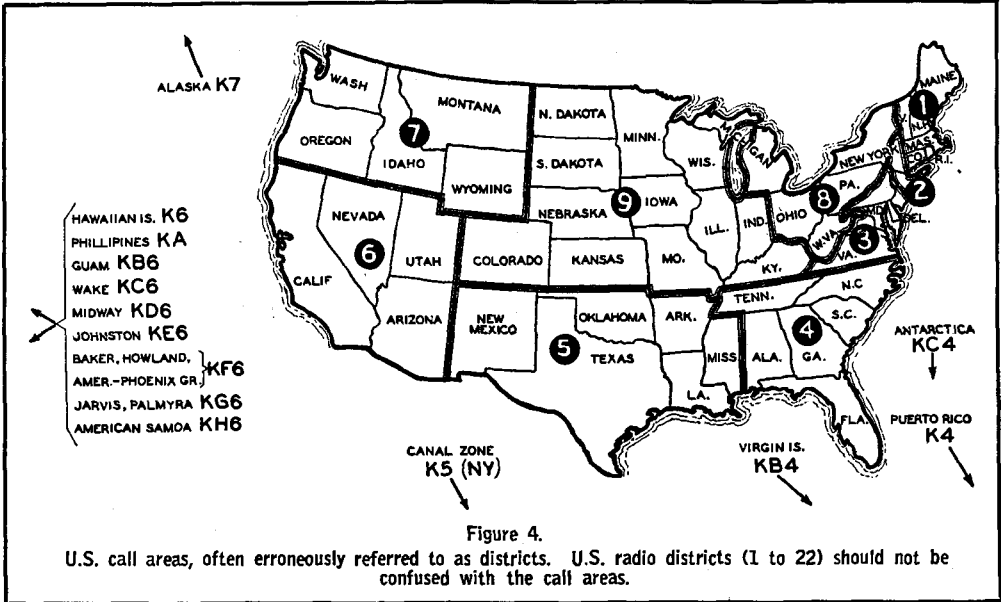

Figure 4.

U.S. call areas, often erroneously referred to as districts. U.S. radio districts (1 to 22) should not be confused with the call areas.

There is one thing you should *not* write to the inspector about and that is the necessity for a license to *transmit*. A transmitter license is absolutely necessary, regardless of power, frequency, or type of emission; there are no exceptions nor special cases.

Before attempting to take the amateur examination, the reader should have a thorough knowledge of the regulations affecting amateur operators and stations. While "memorizing" procedure is not to be recommended when preparing for the *technical* portion of the amateur examination, the best way to prepare for the questions pertaining to regulations is to memorize the pertinent extracts from the communications law and also the United States amateur regulations, given in chapter 27. They do not necessarily have to be memorized verbatim, but the applicant must have at his command *all of the information contained therein*.

It is important that the reader clearly understand the distinction between violations of the basic Communications Act of 1934 and violations of the rules and regulations set up under the basic act by the Federal Communications Commission. The former constitutes the more serious offense, and anyone is liable, whether he be an amateur or not. The difficulty some applicants experience with certain questions is in deciding whether a certain offense is a violation of the basic act or a violation of rules set up by our F.C.C. under the act.

Starting Your Study. When you start

your study to prepare yourself for the amateur examination, you will probably find that the circuit diagrams, tube characteristic curves, and formulas first appear confusing and difficult of comprehension. However, after putting in a few evenings of study, one becomes sufficiently familiar with basic concepts and fundamentals that the acquisition of further knowledge is not only easy but fascinating.

As it takes considerable time to become proficient at sending and receiving code, it is a good idea to start by interspersing technical study sessions with short periods of code practice. There are two reasons for this: many short code practice sessions benefit one much more than a fewer number of comparatively longer sessions. Also, it keeps one from getting "stale" while studying theory and regulations by serving as a rest period, thus serving to maintain one's interest. Each kind of study serves as a respite from the other.

You can even start on one of the simpler receivers described in the chapter on *receiver construction* if you wish, though at first you will be unable to decipher many of the dots and dashes you pick up on it. However, many interesting hours can be spent listening to the conversations of amateur phone stations. The numerous references to "QSA," "Rig," "Rotary," and other mysterious terms will begin to take on significance.

When you have practiced the code long enough, you will be able to follow the gist of the conversation of slower sending code

stations, and fish for "dx." Many stations send slower than "13 per" when working dx. Stations repeat their calls many times when calling "CQ," and one need not have achieved

much proficiency to make out their calls and thus determine their location. Granted that it is advisable to start right in with learning the code, you will want to know how to go about mastering it in the shortest possible time with the least amount of effort.

THE RADIOTELEGRAPH CODE			
A	••	N	••
B	••••	O	••••
C	•••••	P	•••••
D	••••	Q	•••••
E	•	R	•••
F	••••	S	•••
G	••••	T	•
H	••••	U	•••
I	••	V	••••
J	•••••	W	••••
K	••••	X	••••
L	••••	Y	•••••
M	••	Z	•••••
NUMERALS, PUNCTUATION MARKS, ETC.			
1	••••••	6	•••••
2	•••••	7	•••••
3	•••••	8	••••••
4	•••••	9	••••••
5	•••••	Ø	••••••
INTERNATIONAL DISTRESS SIGNAL			
PERIOD	••••••		
COMMA	••••••		
INTERROGATION	••••••		
QUOTATION MARK	••••••		
COLON	••••••		
SEMICOLON	••••••		
PARENTHESIS	••••••		
FRACTION BAR	••••••		
WAIT SIGN	•••••		
DOUBLE DASH (BREAK)	•••••		
ERROR (ERASE) SIGN	•••••••		
END OF MESSAGE	•••••		
END OF TRANSMISSION	••••••		

Figure 5.

Shown above is the Continental code used for all radio communications. The more complicated Morse code is used for land line telegraphic communication within the U.S.A.

Learning the Code

The applicant for an amateur license must be able to send and receive the Continental code at a speed of 13 words per minute, with an average of 5 characters to the word. Thus 65 characters must be copied consecutively without error in one minute. Similarly, 65 consecutive characters must be transmitted without error in that time. The applicant, however, is given sufficient opportunity to pass this code test, since sending and receiving tests are both five minutes in length. If 65 consecutive characters, at the required rate, are copied correctly, somewhere during the first five-minute period, the applicant may then attempt a transmission. Again, if 65 consecutive characters are sent correctly somewhere during this second period, a passing mark is received.

Failure to pass the code test results in a two-month rest period during which the applicant can improve his mastery of the code; thereafter, he may again appear for another try.

Approximately 30 per cent of the amateur license applicants fail to pass the code examination. It should be expected that nervousness and excitement—at least to some degree—will hinder the applicant's code ability. The best prevention against this is to be able to master the code at a little better than the required speed, under ordinary conditions. Then a little slowing down due to nervousness will not prove "fatal" during the strain and excitement of the examination. As to the correct method of learning the code, the following is recommended. Unfortunately, no "trick" short cut to learning the code has been found generally successful.

Memorizing the Characters. To memorize the alphabet entails but a few evenings of diligent application. The time required to build up speed will be entirely dependent upon individual ability and regularity of drill, and may take any length of time from a few weeks to many months.

Since code reading requires that individual letters be recognized instantly, any memorizing scheme which depends upon an orderly sequence, such as learning all "dot" letters and all "dash" letters in separate groups, is to be discouraged.

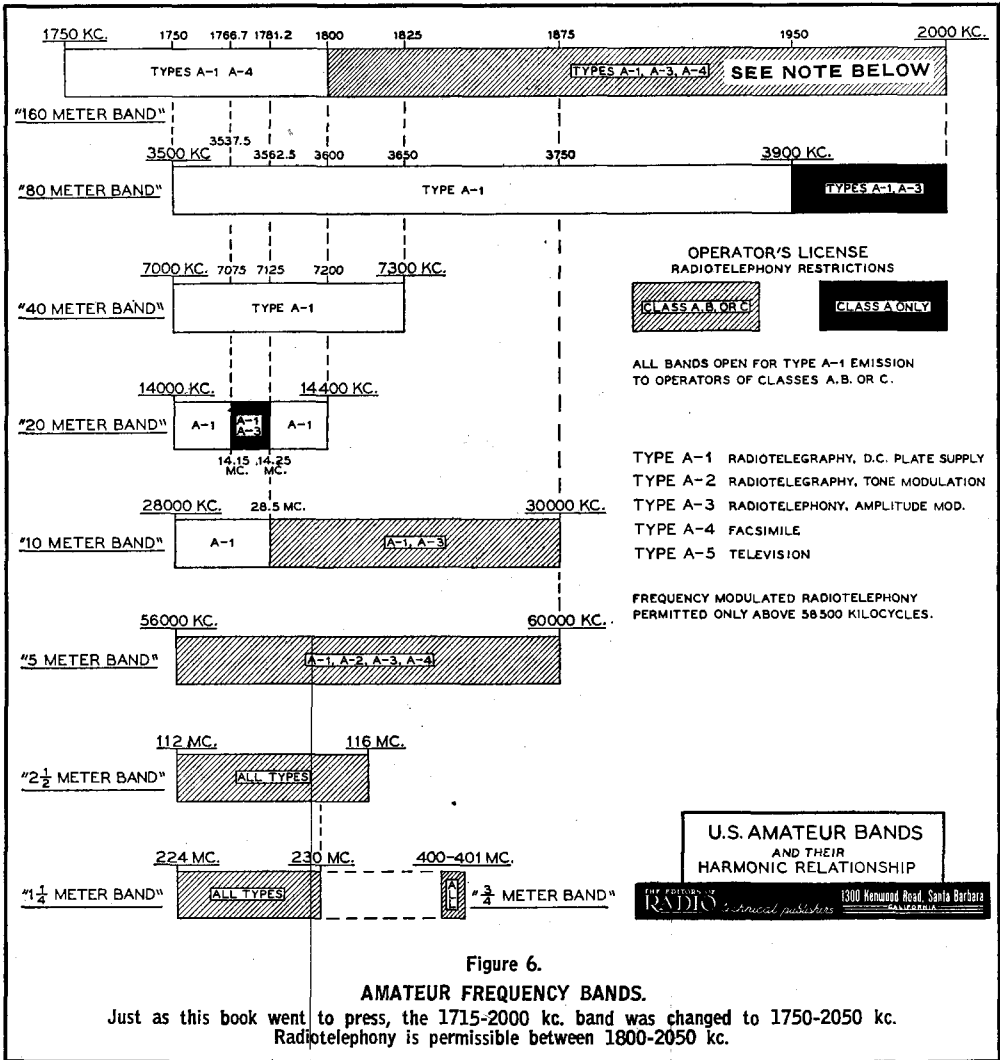

Figure 6.

AMATEUR FREQUENCY BANDS.

Just as this book went to press, the 1715-2000 kc. band was changed to 1750-2050 kc. Radiotelephony is permissible between 1800-2050 kc.

Each letter and figure must be recognized by its *sound* rather than by its appearance. Telegraphy is a system of sound communication, the same as is the spoken word. The letter A, for example, is one short and one long sound in combination, sounding like *did-dah*, and it must be remembered as such, not *dot-dash*.

If you listen to the sound of a letter transmitted slowly by a buzzer and key in the hands of some experienced operator, you will notice how closely the dots resemble the sound *did* and the dashes *dah*.

Before beginning practice with a code-practice set, it is necessary to memorize the whole alphabet perfectly. A good plan is to study only two or three letters a day and to

drill with those letters until they become part of your consciousness. Mentally translate each day's letters into their sound equivalent wherever they are seen—on signs, in papers; indoors and outdoors. Tackle two additional letters in the code chart each day, at the same time reviewing all of the characters already learned.

Avoid memorizing by routine. Be able to sound out any letter immediately without so much as hesitating to think about the letters preceding or following the one in question. Know C, for example, apart from the sequence A, B, C. Skip about among all of the characters learned, and before very long sufficient letters will have been acquired to enable you to spell out simple words to your-

self in "did-dahs." This is interesting exercise, and for that reason it is good to memorize all of the vowels first, the most common letters next.

Actual code practice should start only when the entire code, including numerals and the few commonly used punctuation marks, have been memorized so thoroughly that any letter or figure can be sounded at a moment's notice without hesitation.

Once you have memorized the code thoroughly, you should concentrate on increasing your receiving speed. True, if you practice with another newcomer who is learning the code, you will both have to do some sending. But do not attempt to practice sending just for the sake of increasing your sending speed.

When transmitting on the code practice set to your partner, so that he can get receiving practice, concentrate on the quality of your sending, not on your speed. Your partner will appreciate it, and he could not copy you if you "opened up" anyhow. If you want to get a reputation as having an excellent "fist" on the air, just remember that speed alone won't do the trick. Proper execution of your letters and spacing will make much more of an impression. Fortunately, as you get so that you can send evenly and accurately, your sending speed will automatically increase. Remember, try to see how evenly you can send and how fast you can receive.

Because it is comparatively easy to learn to send rapidly, especially when no particular care is given to the quality of the sending, many amateurs who have just received their licenses get on the air and send mediocre code at 20 words a minute when they can barely receive good code at 13. While most old timers on the air remember their own period of initiation and are only too glad to be patient and considerate if you tell them you are a beginner, the surest way to incur their scorn is to try to impress them with your "lightning

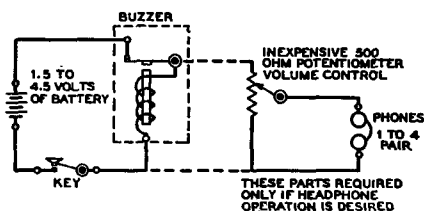

Figure 7.

THE SIMPLEST CODE PRACTICE SET CONSISTS OF A KEY AND BUZZER.

Adjust the buzzer to give a steady, high pitched "whine." If desired, the phones and volume control may be omitted, in which case the buzzer should be mounted firmly on a sounding board.

sending" and then request "QRS" when they come back to you at the same speed.

Code Practice Sets. If you don't feel too foolish doing it, you can secure a measure of code practice with the help of a partner by sending "did dah" messages to each other while riding to work, eating lunch, etc. It is better, however, to use a buzzer or code practice oscillator in conjunction with a regular telegraph key.

As a good key may be considered an investment, it is wise to make a well-made key your first purchase. Regardless of what type code practice set you use, you will need a key, and later on you will need one to key your transmitter. If you get a good key to begin with, you won't have to buy another one later.

The key should be rugged and have fairly heavy contacts. Not only will the key stand up better, but such a key will contribute to the "heavy" type of sending so desirable for radio work. Morse (telegraph) operators use a "light" style of sending and can send somewhat faster when using this light touch. But in radio work static and interference are often present, and a slightly heavier dot is desirable. If you use a husky key, you will find yourself automatically sending in this manner.

Special types of keys, especially the semi-automatic "bug" type, should be left alone by the beginner. Mastery of the standard type key should come first. The correct manner of using such a key will be discussed later.

To generate a tone simulating a code signal as heard on a receiver, either a mechanical buzzer or an audio oscillator (howler) may be used. The buzzer may be mounted on a sounding board in order to increase the fullness and volume of the tone; or it may be mounted in a cardboard box stuffed with cotton in order to silence it and the signal fed

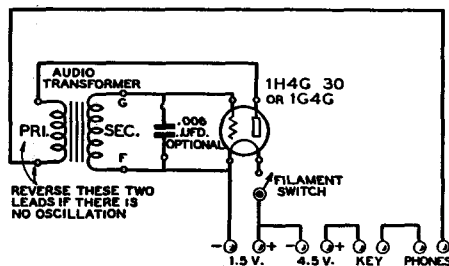

Figure 8.

V.T. CODE PRACTICE OSCILLATOR OF THE SIMPLEST TYPE.

Power is furnished by a dry cell and a $4\frac{1}{2}$ -volt C battery. If the .006- μ fd. condenser is omitted, a higher pitched note will result. The note may have too low a pitch even with the condenser omitted unless you use the smallest, cheapest audio transformer you can find.

into a pair of earphones. The latter method makes it possible to practice without annoying other people as much, though the clicking of the key will no doubt still bother someone in the same room.

A buzzer-type code practice circuit is shown in figure 7. The buzzer should be of good quality or it will change tone during keying; also the contacts on a cheap buzzer will soon wear out. The volume control, however (used only for headphone operation), may be of the least expensive type available, as it will not be subjected to constant adjustment as in a radio receiver. For maximum buzzer and battery life, use the least amount of voltage that will provide stable operation of the buzzer and sufficient volume. Some buzzers operate stably on $1\frac{1}{2}$ volts, while others require more.

A vacuum tube audio oscillator makes the best code practice oscillator, as there is no sound except that generated in the earphones and the note more closely resembles that of a radio signal. Such a code practice oscillator is diagrammed schematically in figure 8. The parts are all screwed to a wood board and connections made to the phones and batteries by means of Fahnestock clips, as illustrated in figure 9. A single dry cell supplies filament power and a $4\frac{1}{2}$ -volt C battery supplies plate voltage. Both filament and plate current are very low, and long battery life can be expected. The vacuum tube is the biggest item from the standpoint of cost, but it can later be used in a field-strength meter with the same batteries supplying power. Such a device is very handy to have around a station, as it can be used for neutralizing,

checking the radiation characteristics of your antenna, etc.

A 1H4, 30, or 1G4G may be used with the same results. The first two are 2-volt tubes, but will work satisfactorily on a 1.5-volt filament battery because of the very small amount of emission required for the low value of plate current drawn. Be sure to get a socket that will accommodate the particular tube you buy.

Oddly, it is important that the audio transformer used *not* be of good quality; if it is, it may have so much inductance that it will be impossible to get a sufficiently high pitched note. If you buy a new transformer, get the smallest, cheapest one you can buy. The old transformers used in moderately priced sets of 12 years ago are fine for the purpose, and can oftentimes be picked up for a small fraction of a dollar at the "junk parts" stores. The turns ratio is not important; it may be anything between 1.5/1 and 6/1.

Correct transformer polarity is necessary for oscillation. If oscillation is not obtained, reverse the two wires going to the primary terminals of the transformer.

The tone may be varied by substituting a larger (.025 μ fd.) or smaller (.001 μ fd.) condenser for the .006- μ fd. capacitor shown in the diagram. A lower capacity condenser will raise the pitch of the note somewhat and vice versa. The highest pitch that can be obtained with a given transformer will result when the condenser is left out of the circuit altogether. Lowering the plate voltage to 3 volts will also have a noticeable effect upon the pitch of the note. If the particular trans-

Figure 9.
THE CIRCUIT OF FIGURE 8 IS USED IN THIS BATTERY OPERATED CODE OSCILLATOR.

A tube and audio transformer essentially comprise the oscillator. Fahnestock clips screwed to the baseboard are used to make connections to batteries, key, and phones.

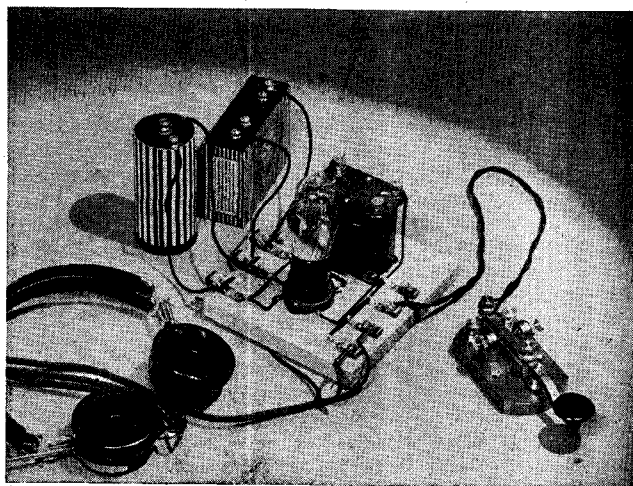



Figure 10.

When special quarters are not available for the station, the entire equipment often is placed in one corner of a den or bedroom, and as in the case of W9UMS, need not detract from the appearance of the room.

former you use does not provide a note of a pitch that suits you, the pitch can be altered in this manner.

Using a 1H4G, a standard no. 6 dry cell for filament power, and a 4½-volt C battery for plate power, the oscillator may be constructed for about \$2.00 exclusive of key and earphones. The filament battery life will be about 700 hours, the plate battery life considerably more. This set has an advantage over an a.c. operated practice set in that it can be used where there is no 110-volt power available; you can take it on a Sunday picnic if you wish. Also, there is no danger of electrical shock.

The carrier-operated keying monitor described in *Chapter Twenty-two* also may be used for code practice, and is recommended where loud speaker operation is desired, such as for group practice.

Automatic Code Machines. The two practice sets just described—the buzzer and the v.t. oscillator—are of most value when you have someone with whom to practice. If you are unable to enlist a code partner and have to practice by yourself, the best way to get receiving practice is by use of a set of phonograph code practice records or a tape machine (automatic code-sending machine) with several practice tapes.

The records are of use only if you have a phonograph whose turntable speed is readily adjustable. The tape machine can be rented by the month for a reasonable fee. Once you can copy close to 10 w.p.m., you can get receiving practice by listening to slow-sending amateurs on your receiver, as amateurs usually send quite slowly when

working extreme dx. However, until you can copy around 10 w.p.m., your receiver isn't of much use and either another operator or a tape machine or code records are necessary for getting receiving practice after you have once memorized the code.

The student must observe the rule always to write down each letter as soon as it is received, never dots and dashes to be translated later. If the alphabet has actually been mastered beforehand, there will be no hesitation from failure to recognize most of the characters unless the transmission speed is too high.

Don't practice too long at one stretch; it does more harm than good. Twenty-five or thirty minutes should be the limit.

Time must not be spent trying futilely to recall a missed letter. Dismiss it and center the attention on the next letter. In order to prevent guessing and to give you equal practice on seldom-used letters such as X, Y, etc., the transmitted material should not be plain language except perhaps for a few minutes out of each practice period.

During the first practice period, the speed should be such that a substantially solid copy can be made of the entire transmission without strain. Then, in the next period, the speed should be increased slightly to a point where all of the characters can be caught only through conscious effort. When the student becomes proficient at this new speed, another slight increase may be made, progressing in this manner until a speed of about 16 words per minute is attained. The margin of 3 w.p.m. is recommended to overcome the possible excitement factor at ex-

amination time. Then when you take the test you don't have to worry about "jitters" or an "off day."

The speed must not be increased to a new level until the student finally makes solid copy for a 5-minute period at the old level. How frequently increases of speed can be made depends upon individual ability and the number of practice hours. Each increase is apt to prove decidedly disconcerting, but keep in mind the statement by Dr. G. T. Buswell, "You are never learning when you're comfortable."

Using A Key. See figure 11 for the proper position of the hand, fingers, and wrist when manipulating the telegraph key. The forearm rests naturally on the desk. The knob of the key is grasped lightly with the thumb along the edge and the index and third fingers resting on the top towards the front edge. The hand moves with a free up and down motion, the wrist acting as a fulcrum. The power comes entirely from the arm muscles. The third and index fingers will bend *slightly* during sending, but not because of conscious effort to manipulate the finger muscles. Keep your finger muscles just tight enough to act as a "cushion" for the arm motion and let the slight movement of the fingers take care of itself.

The key spring is adjusted to the individual wrist and should be neither stiff nor "sloppy." Use a moderately stiff tension at first and gradually lighten it as you get more proficient. The separation between the contacts must be the proper amount for the desired speed, being about 1/16 inch for slow speeds and correspondingly closer together (about 1/32 inch) for faster speeds. Avoid extremes in either direction. It is preferable that the key be placed far enough from the edge of the table (about 18 inches) that the elbow can rest on the table.

The characters must be properly spaced and timed, with the dot as the yardstick. A standard dash is three times as long as a dot. The spacing between parts of the same letter is equal to one dot; between letters, three dots; between words, five dots.

This does *not* apply when sending slower than about 10 words per minute for the benefit of someone learning the code and desiring receiving practice. When sending at say 5 w.p.m., the individual letters should be made the same as though the sending rate were about 10 w.p.m. except that the spacing between letters and words is greatly exaggerated. The reason for this is obvious. The letter L, for instance, will sound exactly the same at 10 w.p.m. as at 5 w.p.m., and

when the speed is increased above 5 w.p.m., the student will not have to become familiar with a new sound (faster combination of dots and dashes). He will merely have to learn the identifying of the *same* sounds without taking so long to do so.

It has been shown that it does not aid a student to identify a letter by sending the individual components of the letter at a speed corresponding to less than 10 words per minute. By sending the letter moderately fast, a longer space can be left between letters for a given code speed, giving the student more time to identify the letter.

When two co-learners have memorized the code and are ready to start sending to each other for practice, it is a good idea to enlist the aid of an experienced operator for the first practice session so that you will get an idea of what properly formed letters sound like.

When you are practicing with another beginner, don't gloat because you seem to be learning to receive faster than he. It may mean that his *sending* is better than yours. Remember that the quality of sending affects the maximum copying speed of a beginner by as much as 100 per cent. Yes, if the sending is bad enough, a newcomer won't be able to read it at all, even though an old timer may be able to get the general drift of what you are trying to send. A good test for any "fist" is to try it on someone who is just getting to the "13 per" stage.

If You Have Trouble. Should you expe-

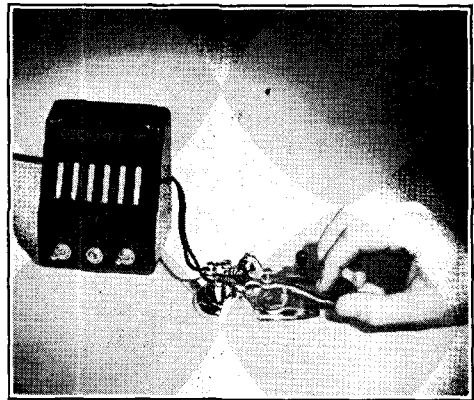

Figure 11.

PROPER POSITION OF FINGERS FOR OPERATING A TELEGRAPH KEY.

The fingers hold the knob and act as a cushion. The hand rests lightly on the key. The muscles of the forearm provide the power, the wrist acting as a fulcrum. The power should not come from the wrist, but rather from the forearm muscles.

CHAPTER TWO

Fundamental Radio and Electrical Theory

Constitution of Matter. All matter is made up of approximately 92 fundamental constituents commonly called *elements*. These elements can exist either in the free state such as iron, oxygen, carbon, copper, tungsten, and aluminum, or in chemical unions commonly called *compounds*. The smallest unit which still retains all the original characteristics of an element is the *atom*.

Combinations of atoms, or subdivisions of compounds, result in another fundamental unit, the *molecule*. The molecule is the smallest unit of any compound. All reactive elements when in the gaseous state also exist in the molecular form, made up of two or more atoms. The nonreactive or noble gaseous elements helium, neon, argon, krypton, xenon, and radon are the only gaseous elements that ever exist in a truly atomic state.

The Atom. An atom is an extremely small unit of matter—there are literally billions of them making up so small a piece of material as a speck of dust. But to understand the basic theory of electricity and hence of radio, we must go further and divide the atom into its main components, a positively charged nucleus and a cloud of negatively charged particles that surround the nucleus. These particles, swirling around the nucleus in elliptical orbits at an incredible rate of speed, are called orbital electrons. It is upon the behavior of these electrons that depends the study of electricity and radio, as well as allied sciences. Actually it is possible to subdivide the nucleus of the atom into other particles: the proton, nuclear electron, negatron, positron, and neutron; but this further subdivision can be left to quantum mechanics and atomic physics. As far as radio theory is concerned it is only necessary to think of

the normal atom as being composed of a nucleus having a net positive charge that is exactly neutralized by the orbital electrons surrounding it.

The atoms of different elements differ in respect to the charge on the positive nucleus and in the number of electrons revolving around this charge. They range all the way from hydrogen, having a net charge of one on the nucleus and one orbital electron, to uranium with a net charge of 92, and 92 orbital electrons. The number of orbital electrons is called the *atomic number* of the element.

From the above it must not be thought that the electrons revolve in a haphazard manner around the nucleus. Rather the electrons in an element having a large atomic number are grouped into "shells" having a definite number of electrons. In the first shell there is room for only two electrons; in the next, 2, the next, 6, then 2, 6, 10, 2, 6, 10, etc., until a total of 92 electrons can be accommodated in the heaviest atom, that of uranium. The only atoms in which these shells are completely filled are those of the inert or noble gases mentioned before; all other elements have one or more uncompleted shells of electrons. If the uncompleted shell is nearly empty, the element is *metallic* in character, being most metallic when there is only one electron in the outer shell. If the incomplete shell lacks only one or two electrons, the element is usually *non-metallic*. Elements with a shell about half completed will exhibit both non-metallic and metallic character; carbon, silicon and arsenic are examples of this type of element.

In metallic elements (elements in which the outer shell is just started and has only one or two electrons) these outer-shell electrons are rather loosely held. Conse-

quently, there is a continuous helter-skelter movement of these electrons and a continual shifting from one atom to another. The electrons which move about in a substance are called *free electrons* and it is the ability of these electrons to drift from atom to atom which makes possible the *electric current*.

The Electric Current. The free electrons in a conductor move constantly about and change their position in a haphazard manner. If, however, the conductor is connected between the positive and negative terminals of a battery, there will be a steady movement of electrons from the negative to positive terminal, in *addition* to the irregular movement of the electrons. This flow constitutes an electric current, but as soon as the battery is removed, the current will cease.

When the battery was first connected to the wire there was an electrostatic attraction between the positive terminal of the battery and the negative electrons, and at the same time there was a repulsion due to the negative terminal of the battery at the other end of the wire. It is the combined action of this attraction and repulsion which causes the current to flow. When the battery is removed the electron drift from one end of the wire to the other ceases and we say that the circuit has been broken and the current stopped.

However, from the above it must not be thought that each free electron that has been set into drift by the current flow travels from one end of the wire to the other. Quite the opposite is true; each free electron travels only an extremely short distance, then instantly passes on its motion, bucket brigade fashion, to a succeeding free electron. Thus in the general drift of electrons along a wire carrying an electric current each electron travels only a short distance and the excess of electrons at one end and the deficiency at the other are balanced by the battery. When the battery is removed the state of normalcy returns; there is still the rapid interchange of free electrons between atoms but there is no general trend in either one direction or the other.

Conductors and Insulators. In the molecular structure of many materials such as glass, porcelain, and mica all electrons are tightly held within their orbits and there are comparatively few free electrons. This type of substance will conduct an electric current only with great difficulty and is known as an *insulator*. An insulator is said to have a high electrical *resistance*.

On the other hand, materials that have a large number of free electrons are known as *conductors*. Most metals, those elements which have only one or two electrons in their outer shell, are good conductors. Silver, copper, and aluminum, in that order, are the best of the common conductors and are said to have the greatest *conductivity*, or lowest resistance to the flow of an electric current.

Resistance. Certain materials have a molecular structure such that when the free electrons are made to flow in a definite direction, there are frequent collisions between them and the individual atoms in the material. The result of these collisions is a *decrease* in the total electron flow. This property of a substance which causes it to resist a steady electron flow is called its *resistance*.

It will require a greater *electromotive force* to produce a given current through a substance with high resistance than to produce the same current in a good conductor. In the case of the conductor virtually all of the electromotive force is effective in producing current, whereas in the resistor a portion is wasted in the form of lost energy due to electron collisions. These collisions cause the material to become heated, and part of the initially-applied electromotive force is thus ultimately lost in the form of heat. This same phenomenon of heat is exhibited when a metal is repeatedly struck by a hammer.

The resistance of a uniform length of material is directly proportional to its length and inversely proportional to its cross sectional area. A wire with a certain resistance for a given length will have twice as much resistance if the length of the wire is doubled. For a given length, doubling the area of cross section of the wire will *halve* the resistance.

It is interesting to note that the resistance of most metals will increase with an increase in temperature. Thus the filament of a vacuum tube or a tungsten-filament lamp will have a much lower resistance when cold than when at normal operating temperature. On the other hand non-metallic conductors such as carbon and silicon and insulators such as glass and porcelain have a lower resistance at high temperatures than when cold.

The resistance of a material or circuit can be expressed by a constant, R , which is equal to the ratio of the applied electromotive force to the current produced. Expressed as an equation:

$$R = \frac{\text{electromotive force}}{\text{current}}$$

This equation constitutes the basis for *Ohm's Law*, which is treated at length in the succeeding text.

Fundamental Electrical Units

The most fundamental of the common electrical units are the *ohm*, the *volt*, and the *ampere*.

The Ohm. The commonly used unit of resistance, or opposition to the flow of an electrical current, is the ohm. The international ohm is the resistance offered by a column of mercury at 0° C., 14.4521 grams in mass, of constant cross-sectional area and 106.300 centimeters in length. The expression *megohm* (1,000,000 ohms) is also sometimes used when speaking of very large values of resistance. By definition, if a voltage of one volt is applied across a resistance of one ohm, a current of one ampere will flow.

The Ampere. The fundamental unit of current, or rate of flow of electricity is the ampere. A current of one ampere will deposit silver from a specified solution of silver nitrate at a rate of 1.118 milligrams per second. Many persons confuse the ampere which is a unit of rate of flow with the *coulomb*, which is a unit of quantity of electricity. A coulomb is equal to 6.28x10¹⁸ electrons, and when this quantity of electrons flows by a given point in every second, a current of one ampere is said to be flowing. An ampere is equal to one coulomb per second; a coulomb is, conversely, equal to one ampere-second. Thus we see that *coulomb* indicates amount, and *ampere* indicates rate of flow.

The Volt. The electrons are driven through the wires and components of a circuit by a force called an *electromotive force*, usually abbreviated *e.m.f.* or *E.M.F.* The unit that denotes this force is called the *volt*. This force or pressure is measured in terms of the difference in the number of electrons at one point with respect to another. This is known as the *potential difference*.

The standard of electromotive force is the Weston cell which at 20° C. has a potential of 1.0183 volts across its terminals. This cell is used only for reference purposes since only an infinitesimal amount of current may be drawn from it without disturbing its characteristics.

The relationship between the electromotive force (voltage), the flow of current (amperes), and the resistance which impedes the flow of current (ohms), is very clearly

expressed in a simple but highly valuable law known as *Ohm's law*.

Ohm's Law. This law states that the current in amperes is equal to the voltage divided by the resistance in ohms. Expressed as an equation:

$$I = \frac{E}{R}$$

If the voltage (E) and resistance (R) are known, the current (I) can be readily found. If the voltage and current are known, and the resistance is unknown, the resistance

(R) is equal to $\frac{E}{I}$. When the voltage is the

unknown quantity, it can be found by multiplying I X R. These three equations are all secured from the original by simple transposition. The expressions are here repeated for quick reference:

$$I = \frac{E}{R} \quad R = \frac{E}{I} \quad E = IR$$

where I is the current in amperes,

R is the resistance in ohms,

E is the electromotive force in volts.

Applying Ohm's Law. As a practical example suppose we take the case where it is desired to place a bleeder resistor which will draw 40 ma. across a 500-volt power supply. In this example both the voltage and the current are known and the resistance value is the unknown; hence, we use the second of the three above equations which states that the voltage in volts divided by the current in amperes will give the desired resistance value in ohms. The current value is given in milliamperes; to convert ma. into amperes the decimal point is moved three points to the left. Hence 40 ma. = .040 amperes.

$$R = \frac{E}{I} = \frac{500}{.04} = 12,500 \text{ ohms}$$

Thus if a 12,500-ohm resistor is placed across a 500-volt plate supply the current passing through the resistor will be 40 ma. or .040 amperes.

Another typical problem for the application of Ohm's law would be a resistance-coupled amplifier whose plate resistor has a value of 50,000 ohms, with a measured current through this resistor of 5 milliamperes. The problem is to find the actual voltage applied to the plate of the tube.

The resistance R is 50,000 ohms. The current I is given as 5 milliamperes; milliamperes must, therefore, first be converted into amperes; .005 amperes equals 5 milliamperes.

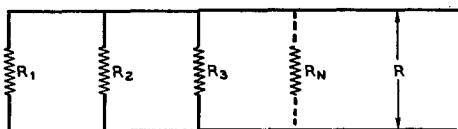

Figure 1.
RESISTORS IN PARALLEL.

The electromotive force or voltage, E , is the unknown quantity. Ohm's law is applied as follows:

$$\begin{aligned} \text{Formula: } E &= I \times R \\ R &= 50,000 \text{ ohms} \\ I &= .005 \text{ amperes} \end{aligned}$$

Solution: $.005 \times 50,000 = 250$ volts drop across the resistor.

If the power supply delivers 300 volts, the actual voltage on the plate of the tube would be only 50 volts. This means that 250 volts of the supply voltage would be consumed in forcing a current of .005 amperes through the 50,000-ohm plate resistor.

As another example suppose that given supply voltage is 300, and that the (measured) voltage on the plate of the tube is 100 volts. Find the current flowing through the plate resistor of 20,000 ohms.

$$\text{From Ohm's law, } I = \frac{E}{R}, \text{ and } E \text{ equals the}$$

difference between supply and measured plate voltages.

Therefore:

$$I = \frac{200}{20,000}$$

$I = 0.010$ amperes, or 10 milliamperes.

Resistances in Series and Parallel. When resistances are connected in series the total value of resistance is equal to the sum of each of the individual resistances. Thus a 2000-ohm resistor in series with a 3000-ohm one would make a total of 5000 ohms—and if another resistor of 5000 ohms were connected in series with the other two the total value would be the sum of all three or 10,000 ohms.

However, when resistors are connected in *parallel* (or shunt as such a connection is sometimes called) the resultant value of resistance is always less than the value of the lowest of the paralleled resistors. It is well to bear this simple law in mind as it will assist greatly in approximating the value of paralleled resistors at a later time. The calculation of the exact values of paralleled resistors will be discussed in the succeeding paragraphs.

Like Values of Resistance in Parallel. When two or more resistances of the same

value are placed in parallel the effective resultant of the paralleled resistors is equal to the value of one of the resistors divided by the number of resistors in parallel. This can be expressed mathematically as:

$$R \text{ (N resistors in parallel)} = \frac{R \text{ (each resistor)}}{N \text{ (number in parallel)}}$$

Thus if (2) resistors of (5000) ohms are placed in parallel the resultant value is 5000 divided by 2, or 2500 ohms. As another example, if (4) resistors of (100,000) ohms are placed in parallel the effective resistance of the paralleled combination is 100,000 divided by 4 or 25,000 ohms.

Unlike Resistances in Parallel. The resultant value of placing a number of unlike resistors in parallel is equal to the reciprocal of the sum of the reciprocals of the various resistors. This can be expressed as:

$$R = \frac{1}{\frac{1}{R_1} + \frac{1}{R_2} + \frac{1}{R_3} + \dots + \frac{1}{R_n}}$$

The effective value of placing any number of unlike resistors in parallel can be determined from the above formula. However, it is commonly used only when there are three or more resistors under consideration since the simplified formula given in the following paragraph is more convenient when only two resistors are being used.

Two Unlike Paralleled Resistors. When two resistances of unlike values are to be used in parallel the following formula may be used to determine their effective resistance:

$$R = \frac{R_1 \times R_2}{R_1 + R_2}$$

where R is the unknown resistance,
 R_1 is the resistance of the first resistor,
 R_2 is the resistance of the second resistor.

A typical example would be an a.v.c. resistor of 500,000 ohms, which is to be shunted (paralleled) with another resistor of some value, in order to bring the effective resistance value down to a value of 300,000 ohms. Substituting these values in the equation for two unequal resistances in parallel:

$$300,000 = \frac{500,000 \times R_2}{500,000 + R_2}$$

By transposition, factoring and solution, the effective value of R will be 750,000 ohms.

Thus a 750,000-ohm resistance must be connected across the 500,000-ohm resistance in order to secure an effective resistance of 300,000 ohms.

In solving for values other than those given, the simplified equation becomes:

$$R_2 = \frac{R_1 \times R}{R - R_1}$$

where R is the resistance present,
 R_1 is the resistance to be obtained,
 R_2 is the value of the unknown resistance necessary to give R_1 when in parallel with R .

Resistances in Series-Parallel. Resistances in series-parallel can be solved from the equation (see figure 2):

$$R = \frac{1}{\frac{1}{R_1 + R_2} + \frac{1}{R_3 + R_4} + \frac{1}{R_5 + R_6 + R_7}}$$

Power in Resistive Circuits. Heat is generated when a source of voltage causes a given current to flow through a resistor. If the flow of current is continually being impeded as a result of an insufficient number of free electrons, there will be countless collisions between the moving electrons and the atoms and the electrons must, therefore, be forced through in order that a given number will move continuously through the conducting medium. This phenomenon results in heating of the conductor, and the heating is the result of loss of useful power or energy.

Wattage. The power in an electrical circuit is expressed in watts and is equal to the product of the voltage and the current flowing in that circuit. Hence W (watts) = EI . Since it is often convenient to express power in terms of the resistance of the circuit and the current flowing through it, a substitution of IR for E ($E = IR$) in the above formula gives: $W = IR \times I$ or $W = I^2R$.

In terms of voltage and resistance, $W = E^2/R$. Here, $I = E/R$ and when this was substituted for I the formula became $W = E \times E/R$ or $W = E^2/R$. To repeat these three expressions for determining wattage in an electrical circuit:

$W = EI$, $W = I^2R$, and $W = E^2/R$,
 where W is the power in watts,
 E is the electromotive force in volts,
 and I is the current in amperes.

To apply the above equations to a typical problem: The voltage drop across a cathode resistor in a power amplifier stage is 50 volts; the plate current flowing through the resistor is 150 milliamperes. The number of watts

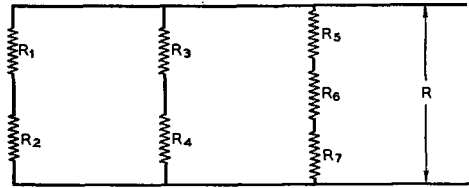

Figure 2.
 RESISTORS IN SERIES PARALLEL.

the resistor will be required to dissipate is found from the formula: W (watts) = $E \times I$, or $50 \times .150 = 7.5$ watts (.150 amperes is equal to 150 milliamperes). From the foregoing it is seen that a 7.5-watt resistor will safely carry the required current, yet a 10- or 20-watt resistor would ordinarily be used to provide a safety factor.

In another problem, the conditions being similar to those above, but with resistance and current being the known factors, the solution is obtained as follows: $W = I^2 \times R = .0225 \times 333.33 = 7.5$.

If only the voltage and resistance are known, $W = \frac{E^2}{R} = \frac{2500}{333.33} = 7.5$ watts.

It is seen that all three equations give the same result; the selection of the particular equation depends only upon the known factors.

Bleeder Resistors. Resistors are often connected across the output terminals of power supplies in order to bleed off a constant value of current or to serve as a constant fixed load. The regulation of the power supply is thereby improved and the voltage is maintained at a more or less constant value, regardless of load conditions. When the load is entirely removed from a power supply, the voltage may rise to such a high value as to ruin the filter condensers.

The amount of current which can be drawn from a power supply depends upon the current rating of the particular power transformer in use. If a transformer will carry a maximum safe current of 100 milliamperes, and if 75 milliamperes of this current is required for operation of a radio receiver, there remains 25 milliamperes of current available which can be wasted in the bleeder resistor.

An example for calculating bleeder resistor values for safe wattage rating is as follows: The power supply delivers 300 volts. The power transformer can safely supply 75 milliamperes of current of which 60 milliamperes will be required for the re-

ceiver. The problem is to find the correct value of resistance to give a bleeder current of 15 milliamperes. Ohm's law gives the solution:

$$R = \frac{E}{I} = \frac{300}{.015} = 20,000 \text{ ohms.}$$

(15 milliamperes is equivalent to .015 ampere.) Therefore, it is seen that the bleeder resistor should have a resistance of 20,000 ohms.

Another problem would be to find the required safe wattage rating of the bleeder, under the same conditions as given in the previous example. The answer is secured as follows: $W = E \times I = 300 \times .015 = 4.5$ watts. It is considered good practice to allow an overload factor of at least 100 per cent, since the voltage will increase somewhat when all load except the bleeder is removed. Therefore, a 10-watt resistor should be chosen.

Voltage Dividers. A voltage divider is exactly what its name implies: a resistor or a series of resistors connected across a source of voltage from which various lesser values of voltage may be obtained by connection to various points along the resistor.

A voltage divider serves a most useful purpose in a radio receiver, transmitter or amplifier, because it offers a simple means of obtaining plate, screen and bias voltages of different values from a common power supply source. It may also be used to obtain very low voltages of the order of .01 to .001 volts with a high degree of accuracy, even though a means of measuring such voltages is lacking. The procedure for making these measurements can best be given in the following example:

Assume that an accurately calibrated 0-150 voltmeter is available and that the source of voltage is exactly 100 volts. This 100 volts is then impressed through a resistance of exactly 1,000 ohms. It will, then, be found that the voltage along various points on the resistor, with respect to the grounded end, will be exactly proportional to the resistance at that point. From Ohm's law, the current would be 0.1 ampere; this current remains unchanged since the original value of resistance (1,000 ohms) and the voltage source (100 volts) are unchanged. Thus, at a 500-ohm point on the resistor (half its entire resistance), the voltage will likewise be halved or reduced to 50 volts.

The equation ($E = I \times R$) gives the proof: $E = 500 \times 0.1 = 50$. At the point of 250 ohms on the resistor, the voltage will

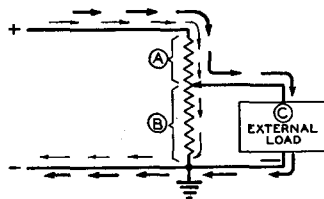

Figure 3.
Indicating the flow of current through a tapped voltage divider to an external load.

be one-fourth the total value or 25 volts ($E = 250 \times 0.1 = 25$). Continuing with this process, a point can be found where the resistance measures exactly one ohm and where the voltage equals 0.1 volt. It is, therefore, obvious that if the original source of voltage and resistance can be measured, it is a simple matter to predetermine the voltage at any point along the resistor, provided that the current remains constant, and provided that no current is taken from the tap on point unless this current is taken into consideration.

Design of Voltage Divider. Proper design of a voltage divider for any type of radio equipment is a relatively simple matter. The first consideration is the amount of bleeder current to be drawn, which is dictated largely by the examples previously given. In addition, it is also necessary that the desired voltage and the exact current at each tap on the voltage divider be known.

The current does not flow from the tap-on point through the resistor to ground or negative terminal, but rather from the positive side, then out through the tap, then through the device to ground. This explanation can be more easily followed by referring to figure 3, wherein the arrows indicate the direction of current flow through the external load and through the voltage divider.

The device which secures current from the voltage divider is indicated as C. The current drawn by C flows through section A of the bleeder resistor, then through C, and back to ground. The bleeder current, however, flows through the entire divider, i.e., through both A and B. Therefore, it becomes apparent that when a tap-on point is chosen to give the voltage desired, it is necessary to consider not only the current drawn by the device C, but also the bleeder current.

The design of more complex voltage dividers can best be illustrated by means of the following problems:

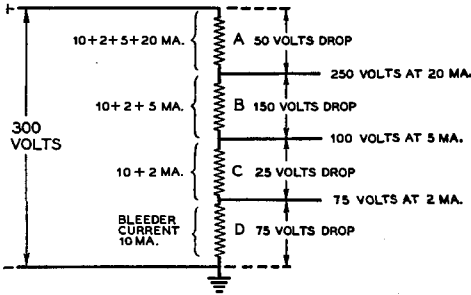

Figure 4.
Combined bleeder resistor and voltage divider as often used in radio receivers.

A power supply delivers 300 volts and is conservatively rated to supply all needed current for the receiver and still allow a bleeder current of 10 milliamperes. The following voltages are wanted: 250 volts at 20 milliamperes for the plates of the tubes, 100 volts at 5 milliamperes for the screens of the tubes, and 75 volts at 2 milliamperes for the detector tube. The voltage drop from the 300-volt value to the required 250 volts would be 50 volts; for the 100-volt value, the drop will be 150 volts; for the 75-volt value, the drop will be 225 volts. These values are shown in the diagram of figure 4. The respective current values are also indicated.

Tabulating the foregoing:

$$A = \frac{\text{Voltage Drop } 50}{\text{Current } .037} = 1,351 \text{ ohms.}$$

$$\text{Dissipation} = .037 \times 50 = 1.85 \text{ watts.}$$

$$B = \frac{\text{Voltage Drop } 150}{\text{Current } .017} = 8,823 \text{ ohms.}$$

$$\text{Dissipation} = .017 \times 150 = 2.25 \text{ watts.}$$

$$C = \frac{\text{Voltage Drop } 26}{\text{Current } .012} = 2,083 \text{ ohms.}$$

$$\text{Dissipation} = .012 \times 25 = 0.3 \text{ watts.}$$

$$D = \frac{\text{Voltage Drop } 75}{\text{Current } .010} = 7,500 \text{ ohms.}$$

$$\text{Dissipation} = .010 \times 75 = 0.75 \text{ watts.}$$

The divider has a total resistance of 19,757 ohms; this value is secured by adding together the four resistance values of 1,351, 8,823, 2,083 and 7,500 ohms. A 20,000-ohm resistor with three sliding taps will, therefore, be of the approximately correct size and, therefore, would ordinarily be used be-

cause of the difficulty in securing four separate resistors of the exact odd values indicated and because no adjustment would be possible to compensate for any slight error in estimating the probable currents through the various taps.

While the wattage dissipation across all the individual sections is only 5.15 watts, the selection of a single resistor, such as a large resistor with several sliders, should be based not only on the wattage rating but also on the current that it will safely carry. In the above example, the wattage of the section carrying the heaviest current is only 1.85 watts. The maximum dissipation of any particular section is 2.25 watts. Yet, if a 5-watt resistor were selected, it would very soon burn up. The reason for this is that *part* of the divider must handle 37 ma.

The selection for wattage rating is, therefore, made on the basis of *current* because wattage rating of resistors assumes uniform current distribution. Most manufacturers rate their resistors in this manner; if not, it can be calculated from the resistance and wattage rating.

When the sliders on the resistor once are set to the proper point, as in the above example, the voltages will remain constant at the values shown as long as the current remains a constant value.

Disadvantages of Voltage Dividers. One of the serious disadvantages of the voltage divider becomes evident when the current drawn from one of the taps changes. It is obvious that the voltage drops are interdependent and, in turn, the individual drops are in proportion to the current which flows through the respective sections of the divider resistor. The only remedy lies in providing a heavy steady bleeder current in order to make the individual currents so small a part of the total current that any change in current will result in only a slight change in voltage. This can seldom be realized in practice because of the excessive values of bleeder current which would be required.

When a power supply is used for C-bias service, still another factor must be taken into consideration. Rectified grid current from the class B or C stages will flow through the divider in the same direction as the bleeder current. If this grid current changes, the voltage applied to the grid will also correspondingly change. Adjustments of a C-bias supply should be made while the amplifier draws its proper amount of grid current; otherwise, the C-bias resistor

setting will be greatly in error. Heavy bleeder currents are thus required for C-bias supplies, especially where the grid current is changing and the bias must remain constant, as in certain types of phone transmitters.

Since the grid current in a C-bias supply flows from the tap on the divider to ground, and in the same direction as the bleeder current, it is important to remember that in this case the regulation is in the opposite direction from the case where power is being taken from a tap on the divider. In other words, the greater the grid current that is flowing through the bleeder, the *higher* will be the voltage at this tap on the divider—and for that matter, at all other taps in the same divider.

Filaments in Series and Parallel. When computations are made for the operation of vacuum tube filaments or heaters in series connection, it should be remembered that each has a definite resistance and that Ohm's law here again holds true, just as it does in the case of a conventional resistance.

No particular problem is involved when two exactly similar tubes of the same voltage and current rating are to be operated with their filaments or heaters connected in series in order to operate them from a source of voltage twice as high as is required for each tube. If two six-volt tubes, each requiring 0.5 ampere for heater operation, are connected in series across a 12-volt power source, each tube will have the same voltage drop (6 volts), and the total current drawn from the power supply will be the same as for one tube or 0.5 ampere. By making this connection, the resistance has actually been doubled; yet, because the voltage is doubled, each tube automatically secures its proper voltage drop.

In this example, the resistance of each tube would be 12 ohms (6 divided by 0.5). In series, the resistance would be twice this value or 24 ohms. The current I would then

equal $12/24$ or 0.5 ampere, from which it can be seen that the current drawn from the supply is the same as for a single tube.

It is important to understand that in a series connection the sum of the voltage drops across all of the tubes in the circuit cannot be more than the voltage of the supply. It is not possible to connect six similar 6-volt tubes in series across a 32-volt supply and expect to realize 6 volts on the filaments of each, since the sum of the various voltage drops is equal to 36 volts. The tubes can, however, be connected in such a manner that the correct voltage drop will be secured as will be explained later.

Different Tubes in Series. A 6F6 and a 6L6 are to be operated in a low-power airplane transmitter. The power supply delivers 12.6 volts. The problem is to connect the heaters of the two tubes in such a manner that each tube will have exactly the same voltage drop across its heater terminals. The *tube tables* show that a type 6F6 tube draws 0.7 ampere at 6.3 volts, while the 6L6 draws 0.9 ampere at the same voltage. The resistance of the 6F6 heater is

$$R = \frac{E}{I} = \frac{6.3}{0.7} = 9 \text{ ohms. Then, the re-}$$

sistance of the 6L6 heater equals $\frac{6.3}{0.9} = 7$ ohms.

If these tubes are connected in series without precautionary measures, the total resistance of the two will be 16 ohms ($9 + 7$). A potential of 12.6 volts will pass a current of 0.787 ampere through this value of 16 ohms. The drop across each separate resistor is found from Ohm's law, as follows: $9 \times 0.787 = 7.083$ volts, and $7 \times 0.787 = 5.4$ volts. Thus, it is seen that neither tube will have the correct voltage drop.

If the tubes are regarded on the basis of their respective current ratings, it will be found that the 6L6 draws 0.9 ampere and the 6F6 0.7 ampere, or a difference of 0.2 ampere. If the resistance of the 6F6 is made equal to that of the 6L6, both tubes will draw the same current. Simply take the difference in current, 0.2 ampere, and divide this value into the proper voltage drop, 6.3 volts; the answer will be 31.5 ohms, which is the value of resistor which must be paralleled with the 6F6 filament to make its resistance the same as that of the 6L6.

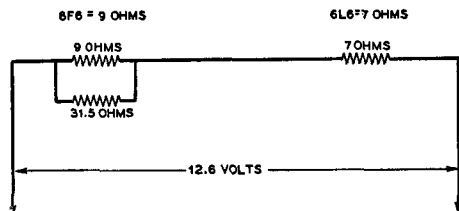

Figure 5.

Obtaining the proper filament voltage drop across each of a pair of dissimilar tubes by means of a resistor across the heater of the one drawing the least amount of current.

When tube heaters or filaments are operated in series, the current is the same throughout the entire circuit. The resistance of all tube filaments must then be made the same if each is to have the same voltage drop across its terminals. The resistance of a tube heater or filament should never be measured when cold because the resistance will be only a fraction of the resistance present when the tube functions at proper heater or filament temperature. The resistance can be calculated satisfactorily by using the current and voltage ratings given in the tube tables.

Electromagnetism

Everyone is familiar with the common bar or horseshoe magnet. The magnetic field which surrounds it allows the magnet to attract nails, washers, or other pieces of iron to it. A peculiarity of an electric current, hence of electrons in motion in general, is that a magnetic field is set up in the vicinity of the conductor of the current for as long a period of time as the current is flowing. A field set up by an electric current is called an *electromagnetic* field to distinguish it from the permanent field surrounding the bar magnet.

Magnetic Flux. The field, or *magnetic lines of force*, set up in the vicinity of the conductor extend outwardly from the conductor in a plane at right angles to its direction. It is these lines of magnetic force that make up the *magnetic flux*. The strength of this flux in the vicinity of a simple conductor is proportional to the strength of the current. However, if the conductor is wound into a coil the flux for each turn of wire becomes additive to that of the others and the flux becomes proportional to the number of turns as well as to the current flow. Since the flux is linearly proportional to both the current and the number of turns, the magnetizing effect of a coil may be described as a function of the ampere-turns of that coil; the magnetizing effect of a coil is proportional to the product of the current strength and the number of turns in the coil.

The magnetic flux increases or decreases in direct proportion to the change in the current. The ratio of the change in flux to the change in current has a constant value known as the *inductance* of a coil.

Electromagnetic Effects. In drawing an analogy of voltage, current and resistance in terms of magnetic phenomena, magnetic flux might be termed *magnetic*

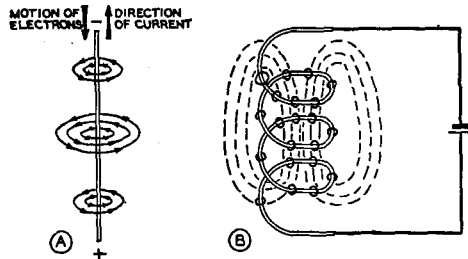

Figure 6.

(A) shows the magnetic lines of force produced around a conductor carrying an electric current. It also indicates the difference between the motion of electrons and the flow of current. (B) indicates how the effectiveness of the field may be increased by winding the conductor into a coil.

current, magnetomotive force or magnetic voltage. The unit of magnetomotive force (m.m.f.) is the *gilbert*. The *reluctance* of a magnetic circuit can be thought of as the resistance of the magnetic path. The relation between the three is exactly the same as that between current, voltage and resistance (Ohm's law).

The magnetic flux depends upon the material, cross section and length of the magnetic circuit, and it varies directly as the current flowing in the circuit. The *reluctance* is dependent upon the length, cross section, permeability and air gap, if any, of the magnetic circuit.

In the electrical circuit, the current would equal the voltage divided by the resistance, and so it is in the magnetic circuit.

$$\text{Magnetic Flux } (\phi) = \frac{\text{magnetomotive force (m.m.f.)}}{\text{reluctance } (\tau)}$$

Permeability. Permeability describes the difference in the magnetic properties of any magnetic substance as compared with the magnetic properties of air. Iron, for example, has a permeability of around 2000 times that of air, which means that a given amount of magnetizing effect produced in an iron core by a current flowing through a coil of wire will produce 2000 times the *flux density* that the same magnetizing effect would produce in air. The permeabilities of different iron *alloys* vary quite widely and permeabilities up to 100,000 can be obtained.

Core Saturation. Permeability is similar to *electric conductivity*. There is, however, one important difference: the permeability of iron is not independent of the magnetic current (flux) flowing through it, although electrical conductivity is usually

independent of electric current in a wire. After a certain point is reached in the flux density of a magnetic conductor, an increase in the magnetizing field will not produce a material increase in flux density. This point is known as the *point of saturation*. The inductance of a choke whose core is saturated declines to a very low value.

Counter E.M.F. A fundamental law of electricity is: when lines of force cut across a conductor, a voltage is induced in that conductor. Therefore, it can be readily seen that in the case of the coil previously mentioned the flux lines from one turn cut across the adjacent turn, and a voltage is induced in that turn. The effect of these induced voltages is to create a voltage across the entire coil of opposite polarity or in the opposite direction to the original voltage. Such a voltage is called *counter e.m.f.* or *back e.m.f.*

If a direct current potential such as a battery is connected across a multiturn coil or inductance, the back e.m.f. will exist at the time when the connection is being made or broken at which time the flux is rising to its maximum value, or falling to zero. While it is true that a current is flowing through the turns of the coil and that a magnetic field exists around and through the center of the inductance, an induced voltage may only be produced by a *changing flux*. It is only such a changing flux that will cut across the individual turns and induce a voltage in them. By a changing flux is meant a flux that is increasing or decreasing as would occur if the e.m.f. across the coil were alternating or changing its direction periodically.

The Unit of Self-Inductance: The Henry. As the current increases, the back e.m.f. reaches a maximum; as the current decreases, the back e.m.f. is maximum in the same direction as the current. This back voltage is always *opposite* to the exciting voltage and, hence, always acts to resist any change in current in the inductance. This property of an inductance is called its *self-inductance* and is expressed in *henrys*, the henry being the unit of inductance. A coil has an inductance of one henry when a voltage of one volt is induced by a current change of one ampere per second. The unit, *henry*, while commonly used in audio frequency circuits is too large for reference to inductance coils such as those used in radio-frequency circuits; *millihenry* or *microhenry* are more commonly used, in the following manner:

1 henry = 1,000 millihenrys, or 10^3 millihenrys.

1 millihenry = 1/1,000 of a henry, .001 henry, or 10^{-3} henry.

1 microhenry = 1/1,000,000 of a henry, or .000001 henry, or 10^{-6} henry.

One one-thousandth of a millihenry = .001 or 10^{-3} millihenrys.

1,000 microhenrys = 1 millihenry.

Mutual Inductance. If two inductances are so placed in relation to each other that the lines of force encircling one coil are interlinked with the turns of the other, a voltage will be set up or *induced* in the second coil. As in the case of self-inductance, the *induced voltage* will be opposite in direction to the exciting voltage. This effect of linking two inductances is called *mutual inductance*, abbreviated *M*, and is also expressed in henrys. Two circuits thus joined are said to be *inductively coupled*.

The magnitude of the mutual inductance depends upon the shape and size of the two circuits, their positions and distances apart and the permeability of the medium. The extent to which two inductances are coupled is expressed by a relation known as *coefficient of coupling*. This is the ratio of the mutual inductance actually present to the maximum possible value.

Inductances in Parallel. Inductances in parallel are combined exactly as are resistors in parallel, provided that they are far enough apart so that the mutual inductance is entirely negligible, i.e., if the coupling is very loose.

Inductances in Series. Inductances in series are additive, just as are resistors in series, again provided that no mutual inductance exists. In this case, the total inductance *L* is:

$$L = L_1 + L_2 + \dots \dots \dots \text{etc.}$$

Where mutual inductance does exist:

$$L = L_1 + L_2 + 2M,$$

where *M* is the mutual inductance.

This latter expression assumes that the coils are connected in such a way that all flux linkages are in the same direction, i.e., additive. If this is not the case and the mutual linkages *subtract* from the self-linkages, the following formula holds:

$$L = L_1 + L_2 - 2M,$$

where *M* is the mutual inductance.

Calculation of Inductance. The inductance of coils with magnetic cores can be determined with reasonable accuracy from the formula:

$$L = 1.257 \times N^2 \times P \times 10^{-8}$$

where

L is the inductance in henrys,

N is the number of turns,

P is the permeability of the core material.

From this formula it can be seen that the inductance is proportional to the *permeability* as well as to the square of the number of turns. Thus, it is possible to secure greater values of inductance with a given number of turns of wire wound on an iron core than would be possible if an air core coil were used.

The inductance of an air core is proportional to the square of the number of turns of wire, provided that the length and diameter remain constant as the turns are changed (actually an impossibility, strictly speaking). The formula for inductance of air core coils is given with good accuracy, as follows:

$$L = N^2 \times d \times F,$$

where:

L = inductance in microhenrys,

d = diameter of coil, measured to center of wire,

N = number of turns,

F = a constant, dependent upon the ratio of length-to-diameter.

This formula is explained under the heading of *Coil Calculation*, where a graph for the constant F is given.

Core Material. Ordinary magnetic cores cannot be used for radio frequencies because the *eddy current losses* in the core material become enormous as the frequency is increased. The principal use for magnetic cores is in the audio-frequency range below approximately 15,000 cycles, whereas at very low frequencies (50 to 60 cycles) their use is mandatory if an appreciable value of inductance is desired.

An air core inductor of only one henry inductance would be quite large in size, yet values as high as 500 henrys are commonly available in small iron core chokes. The inductance of a coil with a magnetic core will vary with the amount of direct current which passes through the coil. For this reason, iron core chokes that are used in power supplies have a certain inductance rating at a *pre-determined value of d.c.*

One exception to the statement that metal core inductances are highly inefficient at radio frequencies is in the *powdered* iron cores used in some types of intermediate frequency transformers. These cores are made of very *fine particles* of powdered iron,

which are first treated with an insulating compound so that each particle is insulated from the other. These particles are then molded into a solid core around which the wire is wound. Eddy current losses are greatly reduced, with the result that these special iron cores are entirely practical in circuits which operate up to 1500 kc. in frequency.

Electrostatic Storage of Energy

So far we have dealt only with the storage of energy in an electromagnetic field in the form of an inductance. The storage of energy in a magnetic field is expressed in *joules* and is equal to $(LI^2)/2$. (A joule is equal to one watt-second.) Electrical energy can also be stored in an electrostatic field. A device capable of storing energy in such a field is called a *condenser* and is said to have a certain *capacitance*. The energy stored in an electrostatic field is also expressed in *joules* and is equal to $CE^2/2$, where C is the capacity in *farads* (a unit of capacity to be discussed) and E is the potential in volts.

Capacitance and Condensers. Two metallic plates separated from each other by a thin layer of insulating material (called a *dielectric*, in this case), become a *condenser*. When a source of d.c. potential is momentarily applied across these plates, they may be said to become charged. If the same two plates are then joined together momentarily by means of a wire, the condenser will *discharge*.

When the potential was first applied, electrons immediately attempted to flow from one plate to the other through the battery or such source of d.c. potential as was applied to the condenser plates. However, the circuit from plate to plate in the condenser was *incomplete* (the two plates being separated by an insulator) and thus the electron flow ceased, meanwhile establishing a shortage of electrons on one plate and a surplus of electrons on the other.

Remember that when a deficiency of electrons exists at one end of a conductor, there is always a tendency for the electrons to move about in such a manner as to reestablish a state of balance. In the case of the condenser herein discussed, the surplus quantity of electrons on one of the condenser plates cannot move to the other plate because the circuit has been broken; that is, the battery or d.c. potential was removed. This leaves the condenser in a *charged* condition; the condenser plate with the electron *deficiency* is *positively* charged, the other plate being *negative*.

In this condition, a considerable stress exists in the insulating material (dielectric) which separates the two condenser plates, due to the mutual attraction of two unlike potentials on the plates. This stress is known as *electrostatic energy*, as contrasted with *electromagnetic energy* in the case of an inductance. This charge can also be called *potential energy* because it is capable of performing work when the charge is released through an external circuit.

The Unit of Capacitance: The Farad. If the external circuit of the two condenser plates is completed by joining the terminals together with a piece of wire, the electrons will rush immediately from one plate to the other through the external circuit and establish a state of equilibrium. This latter phenomenon explains the *discharge* of a condenser. The amount of stored energy in a charged condenser is dependent upon the charging potential, as well as a factor which takes into account the *size* of the plates, *dielectric thickness*, *nature* of the dielectric and the *number* of plates. This factor, which is determined by the foregoing, is called the *capacity* of a condenser and is expressed in *farads*.

The farad is such a large unit of capacity that it is rarely used in radio calculations, and the following more practical units have, therefore, been chosen:

- 1 microfarad = 1/1,000,000 of a farad, or .000001 farad, or 10⁻⁶ farads.
- 1 micro-microfarad = 1/1,000,000 of a microfarad, or .000001 microfarad, or 10⁻⁶ microfarads.
- 1 micro-micro-microfarad = one-million-millionth of a farad, or .000000000001 farad, or 10⁻¹² farads.

If the capacity is to be expressed in *microfarads* in the equation given under *energy storage*, the factor C would then have to be divided by 1,000,000, thus:

$$\text{Stored energy in joules} = \frac{C \times E^2}{2 \times 1,000,000}$$

This storage of energy in a condenser is one of its very important properties, particularly in those condensers which are used in power supply filter circuits.

Dielectric Constant. The capacity of a condenser is largely determined by the thickness and nature of the dielectric separation between plates. Certain materials offer a greater capacity than others, depending upon their physical makeup and chemical constitution. This property is expressed by a constant K, called the dielectric constant. A

table for some of the commonly used dielectrics is given here:

<i>Material</i>	<i>Dielectric Constant</i>
Air	1.00
Mica	5.75
Hard rubber	2.50 to 3.00
Glass	4.90 to 9.00
Bakelite derivatives	3.50 to 6.00
Celluloid	4.10
Fiber4 to 6
Wood (without special preparation):	
Oak	3.3
Maple	4.4
Birch	5.2
Transformer oil	2.5
Castor oil	5.0
Porcelain, Steatite	6.5
Lucite	2.5 to 3.0
Quartz	4.75
Victron, Trolitul	2.6

Dielectric Breakdown. The nature and thickness of a dielectric have a very definite bearing on the amount of charge of a condenser. If the charge becomes too great for a given thickness of dielectric, the condenser will break down, i.e., the dielectric will puncture. It is for this reason that condensers are rated in the manner of the amount of voltage they will safely withstand. This rating is commonly expressed as the *d.c. working voltage*.

Calculation of Capacity. The capacity of two parallel plates is given with good accuracy by the following formula:

$$C = 0.2248 \times K \times \frac{A}{t}$$

where C = capacity in micro-microfarads,
 K = dielectric constant of spacing material,
 A = area of dielectric in square inches,
 t = thickness of dielectric in inches.

This formula indicates that the capacity is directly proportional to the area of the plates and inversely proportional to the thickness of the dielectric (spacing between the plates). This simply means that when the area of the plate is doubled, the spacing between plates remaining constant, the capacity will be doubled. Also, if the area of the plates remains constant, and the plate spacing is doubled, the capacity will be reduced to half. The above equation also shows that capacity is directly proportional to the dielectric constant of the spacing

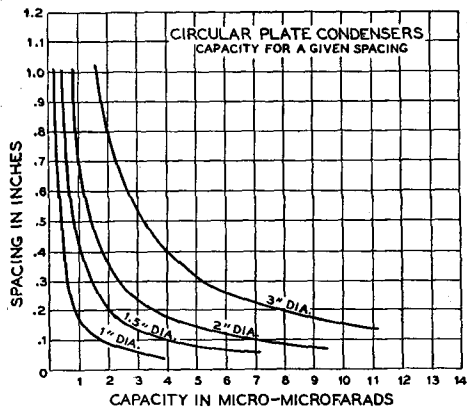

Figure 7.

material. A condenser that has a capacity of 100 $\mu\mu$ fd. in air would have a capacity of 500 $\mu\mu$ fd. when immersed in castor oil, because the dielectric constant of castor oil is 5.0 or five times as great as the dielectric constant of air.

In order to determine the capacity of a parallel plate condenser, the following transposition is of value when the spacing between plates is known:

$$A = \frac{C \times t}{0.2248 \times K}$$

where A = area of plates in square inches,
K = dielectric constant of spacing material,

C = capacity in micro-microfarads,
t = thickness of dielectric (plate spacing) in inches.

Where the area of the plates is definitely set, and when it is desired to know the spacing needed to secure a required capacity,

$$t = \frac{A \times 0.2248 \times K}{C}$$

where all units are expressed just as in the preceding formula. This formula is not confined to condensers having only square or rectangular plates, but also applies when the plates are circular in shape. The only change will be the calculation of the area of such circular plates; this area can be computed by squaring the radius of the plate, then multiplying by 3.1416, or "pi". Expressed as an equation:

$$A = 3.1416 \times r^2,$$

where r = radius in inches.

The capacity of a multi-plate condenser can be calculated by taking the capacity of one section and multiplying this by the number of dielectric spaces. In such cases,

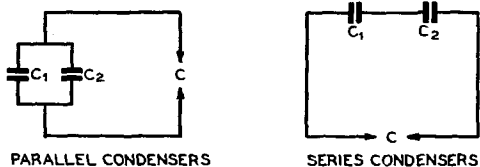

Figure 8.

however, the formula gives no consideration to the effects of edge capacity so that the capacity as calculated will not be entirely accurate. These additional capacities will be but a small part of the effective total capacity, particularly when the plates are reasonably large, and the final result will, therefore, be within practical limits of accuracy.

Equations for calculating capacities of condensers in *parallel* connection are the same as those for resistors in *series*:

$$C = C_1 + C_2, \text{ etc.}$$

Condensers in *series* connection are calculated in the same manner as are resistors in *parallel*.

The formulas are repeated: (1) For two or more condensers of *unequal* capacity in series:

$$C = \frac{1}{\frac{1}{C_1} + \frac{1}{C_2} + \frac{1}{C_3}}$$

$$\text{or } \frac{1}{C} = \frac{1}{C_1} + \frac{1}{C_2} + \frac{1}{C_3}$$

(2) Two condensers of *unequal* capacity in series:

$$C = \frac{C_1 \times C_2}{C_1 + C_2}$$

(3) Three condensers of *equal* capacity in series:

$$C = \frac{C_1}{3}, \text{ where } C_1 \text{ is the common capacity.}$$

(4) Three or more condensers of *equal* capacity in series:

$$C = \frac{\text{Value of common capacity}}{\text{Number of condensers in series}}$$

(5) Six condensers in series parallel:

$$C = \frac{1}{\frac{1}{C_1} + \frac{1}{C_2} + \frac{1}{C_3} + \frac{1}{C_4} + \frac{1}{C_5} + \frac{1}{C_6}}$$

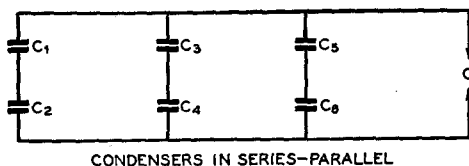

CONDENSERS IN SERIES-PARALLEL

Figure 9.

Voltage Rating of Condensers in Series. Any good paper dielectric filter condenser has such a high internal resistance (indicating a good dielectric) that the exact resistance will vary considerably from condenser to condenser even though they are made by the same manufacturer and are of the same rating. Thus, when 1000 volts d.c. is connected across two 1- μ fd. 500-volt condensers, the chances are that the voltage will divide unevenly and one condenser will receive more than 500 volts and the other less than 500 volts.

Voltage Equalizing Resistors. By connecting a half-megohm 1-watt carbon resistor across each condenser, the voltage will be equalized because the resistors act as a voltage divider and the internal resistances of the condensers are so much higher (many megohms) that they have but little effect in disturbing the voltage divider balance.

Carbon resistors of the inexpensive type are not particularly accurate (not being designed for precision service); therefore it is advisable to check several on an accurate ohmmeter to find two that are as close as possible in resistance. The exact resistance is unimportant, just so it is the same for the two resistors used.

Condensers in Series on A. C. When two condensers are connected in series, *alternating* current pays no heed to the relatively high internal resistance of each condenser, but divides across the condensers in inverse proportion to the *capacity*. Because, in addition to the d.c. across a capacitor in a filter or audio amplifier circuit, there is usually an a.c. or a.f. voltage component, it is inadvisable to series-connect condensers of unequal capacitance even if dividers are provided to keep the d.c. within the ratings of the individual capacitors.

For instance, if a 500-volt 1- μ fd. capacitor is used in series with a 4- μ fd. 500-volt condenser across a 250-volt a.c. supply, the 1- μ fd. condenser will have 200 volts a.c. across it and the 4- μ fd. condenser only 50 volts. An equalizing divider to do any good in this case would have to be of very low resistance because of the comparatively low impedance of the condensers to a.c. Such a divider would

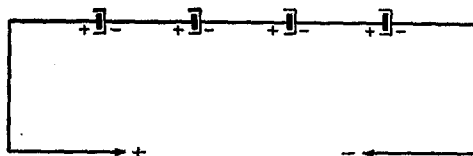

POLARIZED CONDENSERS (ELECTROLYTIC) IN SERIES

Figure 10.

draw excessive current and be impracticable.

The safest rule to follow is to use only condensers of the same capacity and voltage rating and to install matched high resistance proportioning resistors across the various condensers to equalize the d.c. voltage drop across each condenser. This holds regardless of how many capacitors are series-connected.

Electrolytic Condensers in Series. Similar electrolytic capacitors, of the same capacity and made by the same manufacturer, have more nearly uniform (and much lower) internal resistance though it still will vary considerably. However, the variation is not nearly as great as encountered in paper condensers, and the lowest d.c. voltage is across the weakest (leakiest) electrolytic condensers of a series group.

As an electrolytic capacitor begins to show signs of breaking down from excessive voltage, the leakage current goes up, which tends to heat the condenser and aggravate the condition. However, when used in series with one or more others, the lower resistance (higher leakage current) tends to put less d.c. voltage on the weakening condenser and more on the remaining ones. Thus, the capacitor with the *lowest* leakage current, usually the *best* capacitor, has the highest voltage across it. For this reason, dividing resistors are not essential across series-connected electrolytic capacitors.

Electrolytic condensers use a very thin film of oxide as the dielectric, and are polarized; that is, they have a positive and a negative terminal which must be properly connected in a circuit; otherwise, the oxide will boil, and the condenser will no longer be of service. When electrolytic condensers are connected in series, the positive terminal is always connected to the positive lead of the power supply; the negative terminal of the condenser connects to the positive terminal of the *next* condenser in the series combination. The method of connection is illustrated in figure 10.

Alternating Current

To this point in the text, consideration has been given primarily to a current consisting

of a steady flow of electrons in one direction. This type of current flow is known as *unidirectional* or *direct* current, abbreviated *d.c.* Equally as important in radio work and more important in power practice is another and altogether different type of current, known as *alternating current* and abbreviated *a.c.* Power distribution from one point to another and into homes and factories is almost universally *a.c.* On the other hand, the plate supply to vacuum tubes is almost universally *d.c.*

An alternating current begins to flow in one direction, meanwhile changing its amplitude from zero to a maximum value, then down again to zero, from which point it changes its direction, and again goes through the same procedure. Each one of these zero-maximum-zero amplitude changes in a given direction is called a *half cycle*. The complete change in two directions is called a *cycle*. The number of times per second that the current goes through a complete cycle is called the *frequency*. The frequency of common house-lighting alternating current is generally 60 cycles, meaning that it goes through 60 complete cycles (120 reversals) per second. However, 25- and 50-cycle power is to be found quite frequently and 40-, 133-, and 240-cycle power is found in certain foreign countries.

Radio Frequency A. C. Radio frequency currents, on the other hand, go through so many of these alternations per section that the term cycle becomes unwieldy. As an example, it can be said that a certain station in the ten-meter amateur band is operating on 28,640,000 cycles per second. However it is much more convenient to say that the carrier frequency is 28,640 kilocycles, or 28.64 megacycles, per second. A conversion

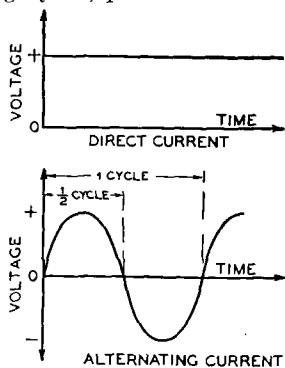

Figure 11.

Graphical comparison of unidirectional or direct current and alternating current.

table for simplifying this terminology is given here:

1,000 cycles = 1 kilocycle. The abbreviation for kilocycle is *kc.*

1 cycle = 1/1,000 of a kilocycle, .001 *kc.* or 10^{-3} *kc.*

1 megacycle = 1,000 kilocycles, or 1,000,000 cycles, 10^3 *kc.* or 10^6 cycles.

1 kilocycle = 1/1,000 megacycle, .001 megacycle, or 10^{-3} *Mc.* The abbreviation for megacycles is *Mc.*

Applying Ohm's Law to Alternating Current. Ohm's law applies equally to direct or alternating current, *provided* the circuits under consideration are purely resistive, that is, circuits which have neither inductance (coils) nor capacitance (condensers). Problems which involve tube filaments, drop resistors, electric lamps, heaters or similar resistive devices can be solved from Ohm's law, regardless of whether the current is direct or alternating. When a condenser or a coil is made a part of the circuit, a property common to either, called *reactance*, must be taken into consideration.

Inductive Reactance. As was previously stated, when an alternating current flows through an inductance, a back- or counter-electromotive force is developed; this force opposes any change in the initial e.m.f. The property of an inductance to offer opposition to a change in current is known as its *reactance* or *inductive reactance*. This is expressed as X_L :

$$X_L = 2\pi fL,$$

where X_L = inductive reactance expressed in ohms.

$$\pi = 3.1416 \quad (2\pi = 6.283),$$

f = frequency in cycles,

L = inductance in henrys.

Inductive Reactance at R. F. It is very often necessary to compute inductive reactance at radio frequencies. The same formula may be used, except that the units in which the inductance and the frequency are expressed will be changed. Inductance can, therefore, be expressed in *millihenrys* and frequency in *kilocycles*. For higher frequencies and smaller values of inductance, frequency is expressed in *megacycles* and inductance in *microhenrys*. The basic equation need not be changed since the multiplying factors for inductance and frequency appear in numerator and denominator, and hence are cancelled out. However, it is not possible in the same equation to express L in millihenrys and f in cycles without conversion factors.

Should it become desirable to know the value of inductance necessary to give a certain

reactance at some definite frequency, a transposition of the original formula gives the following:

$$L = X_L \div (2\pi f)$$

or when X_L and L are known:

$$f = \frac{X_L}{2\pi L}$$

Condensers in A. C. and D. C. Circuits.

When a condenser is connected into a direct current circuit, it will block the d.c., or stop the flow of current. Beyond the initial movement of electrons during the period when the condenser is being charged, there will be no flow of current because the circuit is effectively broken by the dielectric of the condenser. Strictly speaking, a very small current may actually flow because the dielectric of the condenser may not be a perfect insulator. This minute current flow is the leakage current previously referred to and is dependent upon the internal d.c. resistance of the condenser. This leakage current is usually quite noticeable in most types of electrolytic condensers.

When an alternating current is applied to a condenser, the condenser will charge and discharge a certain number of times per second in accordance with the frequency of the alternating voltage. The electron flow in the charge and discharge of a condenser when an a.c. potential is applied constitutes an alternating current, in effect. It is for this reason that a condenser will pass an alternating current yet offer practically infinite opposition to a direct current. These two properties are repeatedly in evidence in a radio circuit.

Capacitive Reactance. It has been explained that inductive reactance is the ability of an inductance to oppose a change in an alternating current. Condensers have a similar property although in this case the opposition is to the *voltage* which acts to charge the condenser. This action is called *capacitive reactance* and is expressed as follows:

$$X_c = \frac{1}{2\pi fC}$$

where X_c = capacitive reactance in ohms,

$$\pi = 3.1416,$$

$$f = \text{frequency in cycles,}$$

$$C = \text{capacity in farads.}$$

Capacitive Reactance at R. F. Here again, as in the case of inductive reactance, the units of capacity and frequency can be converted into smaller units for practical problems encountered in radio work. The equation may be written:

$$X_c = \frac{1,000,000}{2\pi fC}$$

where f = frequency in megacycles,

C = capacity in micro-microfarads.

In the design of filter circuits, it is often convenient to express frequency (f) in *cycles* and capacity (C) in *microfarads*, in which event the same formula applies.

Comparison of Inductive to Capacitive Reactance with Changing Frequency. From the equation for *inductive* reactance, it is seen that as the frequency becomes greater the reactance increases in a corresponding manner. The reactance is doubled when the frequency is doubled. If the reactance is to be very large when the frequency is low, the value of inductance must be very large.

The equation for capacitive reactance shows that the reactance varies *inversely* with frequency and capacity. With a fixed value of capacity, the reactance will become less as the frequency increases. When the frequency is fixed, the reactance will be greater as the capacity is lowered. In order to have high reactance, it is necessary to have low capacitance although in power filter circuits the reactance is always made low so that the alternating current component from the rectifier will be by-passed. The capacitance must be made large in this case because the frequency is quite low (60-120 cycles).

A comparison of the two types of reactance, inductive and capacitive, shows that in one case (inductive) the reactance *increases* with frequency, whereas in the other (capacitive) the reactance *decreases* with frequency.

Reactance and Resistance in Combination. When a circuit includes a capacity or an inductance or both, in addition to a resistance, the simple calculations of Ohm's law will *not* apply when the total impedance to alternating current is to be determined. Reference is here made to the passage of an *alternating current* through the circuit; the reactance must be considered in addition to the d.c. resistance because reactance offers an opposition to the flow of alternating current.

When alternating current passes through a circuit which contains only a condenser, the voltage and current relations are as follows:

$$E = IX_c, \text{ and } I = \frac{E}{X_c}$$

where E = voltage,

I = current in amperes,

$$X_c = \text{capacitive reactance or } \frac{1}{2\pi fC}$$

(expressed in ohms).

When the circuit contains inductance only, yet with the same conditions as above, the formula is as follows:

$$E = IX_L, \text{ and } I = \frac{E}{X_L},$$

where E = voltage,

I = current in amperes,

X_L = inductive reactance or $2\pi fL$
(expressed in ohms).

When a circuit has resistance, capacitive reactance and inductive reactance in *series*, the effective total opposition to the alternating current flow is known as the *impedance* of the circuit. Stated otherwise, impedance of a circuit is the vector sum of the resistance and the difference between the two reactances.

$$Z = \sqrt{r^2 + (X_L - X_c)^2} \text{ or}$$

$$Z = \sqrt{r^2 + \left(2\pi fL - \frac{1}{2\pi fC}\right)^2}$$

where Z = impedance in ohms,

r = resistance in ohms,

X_L = inductive reactance
($2\pi fL$) in ohms,

X_c = capacitive reactance $\left(\frac{1}{2\pi fC}\right)$

in ohms.

An example will serve to clarify the relationship of resistance and reactance to the total impedance. If a 10-henry choke, a 2- μ fd. condenser and a resistance of 10 ohms (which is represented by the d.c. resistance of the choke) are all connected in *series* across a 60-cycle source of voltage:

for reactance $X_L = 6.28 \times 60 \times 10 = 3,750$
ohms (approx.),

$$X_c = \frac{1,000,000}{6.28 \times 60 \times 2} =$$

1,300 ohms (approx.).
 $r = 10$ ohms

Substituting these values in the impedance equation:

$$Z = \sqrt{10^2 + (3750 - 1300)^2} = 2450 \text{ ohms.}$$

This is nearly 250 times the value of the d.c. resistance of 10 ohms. The subject of impedance is more fully covered under *Resonant Circuits*.

Generation of Alternating Current.

Again recalling previous text, an alternating current is one which rises to a maximum, then decreases to zero from that point,

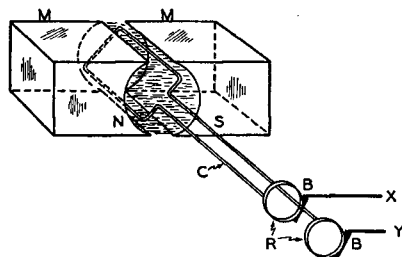

Figure 12.
Schematic representation of the simplest form of the alternator.

and then goes through the same sequence in the opposite direction. This continual change of amplitude and direction is maintained as long as the current continues to flow. The number of times that the current changes direction in a given length of time is called the frequency of change, or more generally, it is simply called the *frequency*.

Alternating currents which range from nearly zero to many millions of cycles per second are commonplace in radio applications. Such a current is produced by the rotating machine which generates the common 60-cycle house-lighting current; it is likewise produced by oscillatory circuits for the high radio frequencies. A machine that produces alternating current for house-lighting, industrial and other uses is called an *alternator*. It is also called an *a.c. generator*.

An alternator in its very basic form is shown in figure 12. It consists of two permanent magnets, M, the opposite poles of which face each other, and the poles being machined so that they have a common radius. Between these two poles, *north* (N) and *south* (S), magnetic lines of force exist; these lines of force constitute a *magnetic field*. If a conductor in the form of C is so suspended that it can freely rotate between the two poles, and if the opposite ends of conductor C are brought to collector rings, R, which are contacted by brushes, there will be a flow of alternating current when conductor C is rotated. This is the basic method of producing alternating current.

If the conductor loop is rotated so that it cuts or passes through the magnetic lines of force between the pole pieces (magnets), a current will be induced in the loop, and this current will flow out through the collector rings R and brushes B to the external circuit, X-Y. As the rotation con-

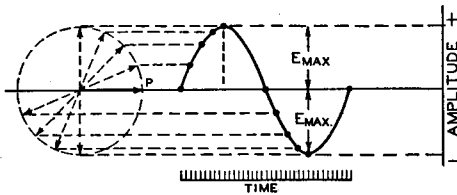

Figure 13.

Graph showing the voltage output of a single-turn conductor revolving in a magnetic field.

tinues, the current becomes increasingly greater as the center of each pole piece is approached by the loop.

The field intensity between the two pole pieces is substantially constant from one side to the other. However, as the conductor is rotated it can easily be seen that it will cut fewer magnetic lines of force when it is running essentially parallel to the lines at either side of the pole pieces than it will cut when it is running essentially perpendicular to them as it is when in the center of the pole pieces. After the conductor has rotated through 180° it can be seen that its position with respect to the pole pieces will be exactly the opposite to that when it started. Hence, the second 180° of rotation will produce a current starting from zero, rising to a maximum, and falling again to zero, but this current will flow in the opposite direction to that of the first half-cycle of rotation.

Actually the voltage does *not* increase directly as the angle of rotation, but rather as the *sine* of the angle; hence, such a current has the mathematical form of a *sine wave*. Although most electrical machinery does not produce a strictly pure sine curve, the departures are usually so slight that the assumption can be regarded as fact for most practical purposes.

Referring to figure 14, it will be seen that if a curve is plotted for an alternating voltage, such a curve would assume the shape of a sine wave and by plotting amplitude against time, the voltage at any instant could be found. When dealing with alternating current of sine wave character, it becomes necessary to make constant use of terms which involve the number of changes in *polarity* or, more properly, the *frequency* of the current. The instantaneous value of voltage at any given instant can be calculated as follows:

$$e = E_{\max} \sin 2\pi ft,$$

where e = the instantaneous voltage,
 \sin = the sine of the angle formed by

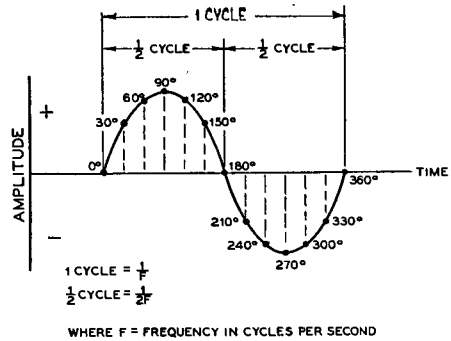

Figure 14.

the revolving point P at the instant of time, t .
 E = maximum crest value of voltage (figure 14).

The term $2\pi f$ should be thoroughly understood because it is of basic importance. Returning again to the rotating point P (figure 13), it can be seen that when this point leaves its horizontal position and begins its rotation in a counter-clockwise direction, through a complete revolution back to its initial starting point, it will have traveled through 360 electrical degrees. Instead of referring to this movement in terms of degrees, mathematical treatment dictates that the movement be expressed in *radians* or segments equal to the radius.

Radians. If radians must be considered in terms of degrees, there are approximately 57.32 degrees in one radian. In simple language, the radian is nothing more than a unit for dividing a circle into many parts. In a complete circle (360 degrees), there are 2π radians. Figure 15 shows lesser divisions of a circle in radians.

When the expression 2π radians is used, it implies that the current or voltage has gone through a complete circle of 360 elec-

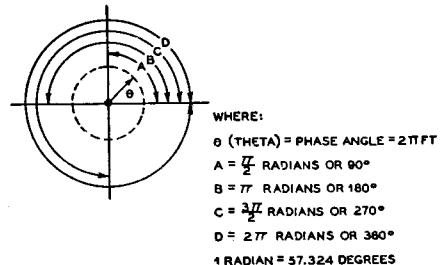

Figure 15.

trical degrees; this rotation represents two complete changes in direction during one cycle, as was previously shown. $2\pi f$ then represents one cycle, multiplied by the number of such cycles per second or the frequency of the alternating voltage or current. The expression $2\pi ft$ is a means of showing how far point P has traveled from its zero position toward a possible change of 2π radians or 360 electrical degrees.

In the case of an alternating current with a frequency of 60 cycles per second, the current must pass through *twice* 60 or 120 changes in polarity in the same length of time. This time can be expressed as:

$$\frac{1}{2f}$$

However, the only consideration at this point is one half of one alternation, and because the wave is symmetrical between 0 and 90 degrees rising, and from 90 degrees to zero when falling, the expression therefore becomes:

$$\frac{1}{4f}$$

The actual time, t , in the formula is seen to be only a fractional portion of a second;

a 60-cycle frequency would make $\frac{1}{4f}$ equal

to $\frac{1}{240}$ of a second at the maximum value,

and correspondingly less at lower amplitudes. $2\pi ft$ represents the *angular velocity*, and since the instantaneous voltage or current is proportional to the *sine* of this angle, a definite means is secured for calculating the voltage at any instant of time, provided that the wave very closely approximates a sine curve.

Current and voltage are synonymous in the foregoing discussion since they both follow the same laws. The instantaneous current can be found from the same formula, except that the maximum current would be used as the reference, viz:

$$i = I_{max} \sin 2\pi ft,$$

where i = instantaneous current,
 I_{max} = maximum or peak current.

Effective Value of Alternating Voltage or Current. An alternating voltage or current in an a.c. circuit is rapidly changing in direction, and since it requires a definite amount of time for the indicator needle on a d.c. measuring instrument to show a de-

flection, such instruments cannot be used to measure alternating current or voltage. Even if the needle had such negligible damping that it could be made to follow the a.c. changes, it would merely vibrate back and forth near the zero point on the meter scale.

Alternating and direct current can be expressed in similar terms from the standpoint of heating effect. In other words, an alternating current will have the same value as a direct current in that it produces the same heating effect. Thus, an alternating current or voltage will have an equivalent value of one ampere when it produces the same heating effect in a resistance as does one ampere of direct current. This is known as the *effective value*; it is neither the maximum nor the instantaneous value, but an entirely different value.

This effective value is derived by taking the instantaneous values of current over a cycle of alternating current, then squaring these values, then taking an average of this value, and then taking the square root of the average thus obtained. By this procedure, the *effective* value becomes known as the *root mean square* or *r.m.s.* This is the value that is read on alternating current voltmeters and ammeters. The r.m.s. value is 70.7 per cent of the peak or maximum instantaneous value and is expressed as follows:

$$E_{eff} = 0.707 \times E_{max}, \text{ or}$$

$$I_{eff} = 0.707 \times I_{max},$$

where E_{max} and I_{max} are peak values of voltage and current respectively, and E_{eff} and I_{eff} are effective or r.m.s. values.

The following relations are extremely useful in radio and power work:

$$E_{rms} = 0.707 \times E_{max},$$

$$E_{max} = 1.414 \times E_{rms}.$$

In order to find the peak value when the effective or r.m.s. value is known, simply multiply the r.m.s. value by 1.414. When the peak value is known, multiply it by 0.707 to find the r.m.s. value.

Rectified Alternating Current or Pulsating Direct Current. If an alternating current is passed through a full-wave rectifier, it emerges in the form of a current of *vary-*

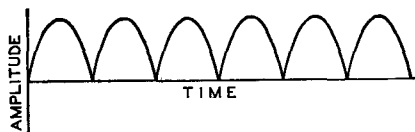

Figure 16.
 Waveform output from a full-wave rectifier.

ing amplitude which flows in one direction only. Such a current is known as *rectified a.c.* or *pulsating d.c.* A typical wave form of a pulsating direct current as would be obtained from the output of a full-wave rectifier is shown in figure 16.

Measuring instruments designed for d.c. operation will not read the peak or instantaneous maximum value of the pulsating d.c. output from the rectifier; it will read only the *average value*. This can be explained by assuming that it could be possible to cut off some of the peaks of the waves, using the cut-off portions to fill in the spaces that are open, thereby obtaining an *average d.c. value*. A milliammeter and voltmeter connected to the adjoining circuit, or across the output of the rectifier, will read this average value. It is related to *peak* value by the following expression:

$$E_{avg} = 0.636 \times E_{max}$$

It is thus seen that the average value is 63.6 per cent of the peak value.

Relationship between peak, r.m.s. or effective, and average values. To summarize the three most significant values of an a.c. wave: the peak value is equal to 1.41 times the r.m.s. or effective, and the r.m.s. value is equal to 0.707 times the peak value; the average value of a full-wave rectified a.c. wave is 0.636 times the peak value, and the average value of a rectified wave is equal to 0.9 times the r.m.s. value. This latter factor is of value in determining the voltage output from a power supply which operates with a choke-input filter system. If the input choke is of the swinging type and is of ample inductance, the d.c. voltage output of the power supply will be 0.9 times the r.m.s. a.c. output of the used secondary of the transformer (one-half secondary voltage in the case of a full-wave rectifier and the full secondary voltage in the case of bridge rectification) less the drop in the rectifier tubes (usually negligible) and the drop in the filter inductances.

Phase. When an alternating current flows through a purely resistive circuit, it will be found that the current will go through maximum and minimum in perfect step with the voltage. In this case the current is said to be in step or *in phase* with the voltage. For this reason, Ohm's law will apply equally well for a.c. or for d.c. where pure resistances are concerned, provided that the *effective* values of a.c. are used in the calculations.

If a circuit has capacity or inductance or both, in addition to resistance, the current does not reach a maximum at the same instant as the voltage; therefore Ohm's law

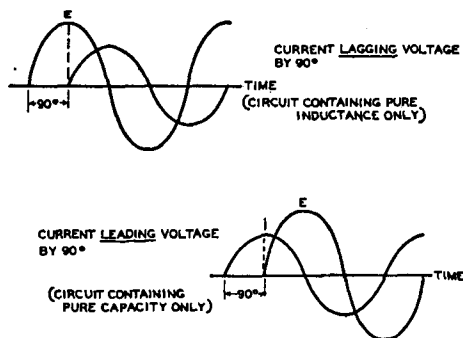

Figure 17.

The above two illustrations show the manner in which a pure inductance or a pure capacitance (no resistance component in either) will cause the current in the circuit either to lead or to lag the voltage by 90°.

will not apply. It has been stated that inductance tends to resist any change in current; when an inductance is present in a circuit through which an alternating current is flowing, it will be found that the current will reach its maximum *behind* or later than the voltage. In electrical terms, the current will *lag* behind the voltage or, conversely, the voltage will *lead* the current.

If the circuit is *purely* inductive, i.e., if it contains neither resistance nor capacitance, the current does not start until the voltage has first reached a maximum; the current, therefore, *lags* the voltage by 90 degrees as in figure 17. The angle will be less than 90 degrees if resistance is in the circuit.

When pure *capacity* alone is present in an a.c. circuit (no inductance or resistance of any kind), the opposite effect will be encountered; the current will reach a maximum at the instant the voltage is starting and, hence, will *lead* the voltage by 90 degrees. The presence of resistance in the circuit will tend to decrease this angle.

Power Factor. It should now be apparent to the reader that in such circuits that have reactance as well as resistance, it will not be possible to calculate the power as in a d.c. circuit or as in an a.c. circuit in which current and voltage are in-phase. The reactive components cause the voltage and current to reach their maximums at different times, as was explained under *phase*, and to calculate the power in such a circuit we must use a value called the *power factor* in our computations.

The *power factor* in a resistive-reactive a.c. circuit may be expressed as the *actual* watts (as measured by a watt-meter) divided by the product of voltage and current or:

$$\frac{W}{E \times I}$$

where W = watts as measured,
 E = voltage (r.m.s.)
 I = current in amperes (r.m.s.).

Stated in another manner:

$$\frac{W}{E \times I} = \cos\theta$$

The character θ is the angle of phase difference between current and voltage. The product of volts times amperes gives the *apparent* power of the circuit, and this must be multiplied by the $\cos\theta$ to give the *actual* power. This factor $\cos\theta$ is called the *power factor* of the circuit.

When the current and voltage are in-phase, this factor is equal to 1. Resonant or purely resistive circuits are then said to have unity power factor, in which case

$$W = E \times I, W = I^2R, W = \frac{E^2}{R}$$

Resonant Circuits

The reader is advised to review at this point the subject matter on inductance, capacity and alternating current in order that he may gain a complete understanding of the action of resonant circuits. Once the basic conception of the foregoing has been mastered, the more complex circuits in which they appear in combination will present no great problem.

Figure 18 shows an inductance, a capacitance and a resistance arranged in series, with a variable frequency source, E, of a.c. applied across the combination.

Some resistance is always present in a circuit because it is possessed in some degree by both the inductance and capacitor. If the frequency of the alternator E is varied from nearly zero to some high frequency, there will be one particular frequency at which the inductive reactance and capacitive reactance will be equal. This is known as the

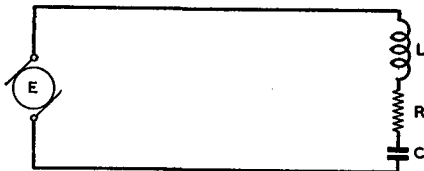

Figure 18.
 Schematic of a series-resonant circuit containing resistance.

resonant frequency, and in a series circuit it is the frequency at which the circuit current will be a maximum. Such series resonant circuits are chiefly used when it is desirable to allow a certain frequency to pass through the circuit (low impedance to this frequency), while at the same time the circuit is made to offer considerable opposition to currents of other frequencies.

If the values of inductance and capacity both are fixed, there will be only one resonant frequency.

For mechanical reasons, it is more common to change the capacitance rather than the inductance when a circuit is tuned, yet the inductance can be made variable if desired.

In the following table there are five radically different ratios of L to C (inductance to capacitance) each of which satisfies the resonant condition, $X_L = X_C$. When the frequency is constant, L must increase and C must decrease in order to give equal reactance. Figure 19 shows how the two reactances change with frequency; this illustration will greatly aid in clarifying this discussion.

If both the inductance and capacitance are made variable, the circuit may then be changed or *tuned*, so that a number of combinations of inductance and capacitance can resonate at the same frequency. This can be more easily understood when one considers that inductive reactance and capacitive reactance travel in opposite directions as the frequency is changed. For example, if the frequency were to remain constant and the values of inductance and capacitance were then changed, the following combinations would have equal reactance:

Frequency is constant at 60 cycles.

L is expressed in henrys.

C is expressed in microfarads (.000001 farad.)

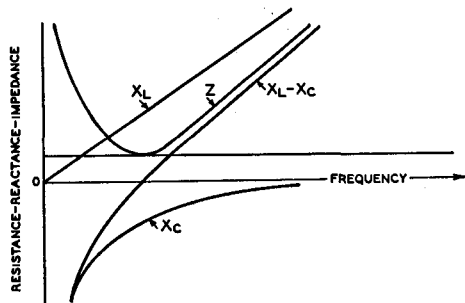

Figure 19.
 Variation in reactance and impedance of a series resonant circuit with changing frequency.

L	X _L	C	X _C
.265	100	26.5	100
2.65	1,000	2.65	1,000
26.5	10,000	.265	10,000
265.00	100,000	.0265	100,000
2,650.00	1,000,000	.0026	1,000,000

Frequency of Resonance. From the formula for resonance,

$$2\pi fL = \frac{1}{2\pi fC}, \text{ the resonant frequency}$$

can readily be solved. In order to isolate f on one side of the equation, merely multiply both sides by 2πf, thus giving:

$$4\pi^2 f^2 L = \frac{1}{C}$$

Divided by the quantity 4π²L, the result is:

$$f^2 = \frac{1}{4\pi^2 LC}$$

Then, by taking the square root of both sides: f =

$$\frac{1}{2\pi\sqrt{LC}}$$

where f = frequency in cycles,
L = inductance in henrys,
C = capacity in farads.

It is more convenient to express L and C in smaller units, especially in making radio-frequency calculations; f can also be expressed in megacycles or kilocycles. A very useful group of such formulas is:

$$f^2 = \frac{25,330}{LC} \text{ or } L = \frac{25,330}{f^2 C} \text{ or } C = \frac{25,330}{f^2 L}$$

where f = frequency in megacycles,
L = inductance in microhenrys,
C = capacity in micromicrofarads.

In order to clarify the original formula, f = $\frac{1}{2\pi\sqrt{LC}}$, take two values of inductance and capacitance from the previously given chart and substitute these in the formula. It was stated that the frequency is 60 cycles; therefore f = 60. Substituting these values to check the frequency:

$$60 = \frac{1}{2\pi\sqrt{LC}}; 3600 = \frac{1}{4\pi^2 LC}$$

$$L = \frac{3600 \times 4\pi^2 \times .000026}{1}$$

$$L = 0.27$$

The significant point here is that the formula calls for C in farads, whereas the capacity was actually in microfarads. Recalling that one microfarad equals .000001 farad, it is, therefore, possible to express 26 microfarads as .000026 farads. This consideration is often overlooked when computing for frequency and capacitive reactance because capacitance is expressed in a totally impractical unit, viz: the farad.

Impedance of Series Resonant Circuits. The impedance across the terminals of a series resonant circuit (figure 18) is

$$Z = \sqrt{r^2 + (X_L - X_C)^2},$$

where Z = impedance in ohms,
r = resistance in ohms,
X_C = capacitive reactance in ohms,
X_L = inductive reactance in ohms.

From this equation, it can be seen that the impedance is equal to the vector sum of the circuit resistance and the difference between the two reactances. Since at the resonant frequency X_L equals X_C, the difference between them (figure 19) is obviously zero so that at resonance the impedance is simply equal to the resistance of the circuit; therefore, because the resistance of most normal radio-frequency circuits is of a very low order, the impedance is also low.

At frequencies higher and lower than the resonant frequency, the difference between the reactances will be a definite quantity and will add with the resistance to make the impedance higher and higher as the circuit is tuned off the resonant frequency.

Current and Voltage in Series Resonant Circuits. Formulas for calculating currents and voltages in a series resonant circuit are similar to those of Ohm's law.

$$I = \frac{E}{Z} \quad E = IZ$$

The complete equations:

$$I = \frac{E}{\sqrt{r^2 + (X_L - X_C)^2}}$$

$$E = I \sqrt{r^2 + (X_L - X_C)^2}$$

Inspection of the above formulas will show the following to apply to series resonant circuits: When the impedance is low, the current will be high; conversely, when the impedance is high, the current will be low.

Since it is known that the impedance will be very low at the resonant frequency, it follows that the current will be a maximum at this point. If a graph is plotted of the cur-

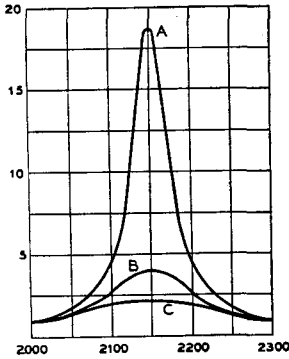

Figure 20.

Resonance curve showing the effect of resistance upon the selectivity of a tuned circuit.

rent against the frequency either side of resonance, the resultant curve becomes what is known as a *resonance curve*. Such a curve is shown in figure 20.

Several factors will have an effect on the shape of this resonance curve, of which resistance and L-to-C ratio are the important considerations. The curves B and C in figure 20 show the effect of adding increasing values of resistance to the circuit. It will be seen that the peaks become less and less prominent as the resistance is increased; thus, it can be said that the *selectivity* of the circuit is thereby *decreased*. Selectivity in this case can be defined as the ability of a circuit to discriminate against frequencies adjacent to the resonant frequency.

Referring again to figure 20, it can be seen from curve A that a signal, for instance, will drop from 19 to 5, or more than 10 decibels, at 50 ke. off resonance. Curve B, which represents considerable resistance in the circuit, shows a signal drop of from 4 to 2.3, or approximately 4 decibels, when the signal is also 50 kilocycles removed from the resonant point. From this it becomes evident that the steeper the resonant curve, the greater will be the change in current for a signal removed from resonance by a given amount. The effect of adding more resistance to the circuit is to flatten off the peaks without materially affecting the sides of the curve. Thus, signals far removed from the resonance frequency give almost the same value of current, regardless of the amount of resistance present.

Voltage Across Coil and Condenser in Series Circuit. Because the a.c. or r.f. voltage across a coil and condenser is proportional to the reactance (for a given current), the actual voltages across the coil and across

the condenser may be many times greater than the *terminal* voltage of the circuit. Furthermore, since the individual reactances can be very high, the voltage across the condenser, for example, may be high enough to cause flashover even though the applied voltage is of a value considerably below that at which the condenser is rated.

Circuit Q—Sharpness of Resonance. An extremely important property of an inductance is its factor-of-merit, more generally called its *Q*. It is this factor, *Q* which primarily determines the sharpness of resonance of a tuned circuit. This factor can be expressed as the ratio of the reactance to the resistance, as follows:

$$Q = \frac{2\pi fL}{R},$$

where *R* = total d.c. and r.f. resistances.

The actual resistance in a wire or inductance can be far greater than the d.c. value when the coil is used in a radio-frequency circuit; this is because the current does not travel through the entire cross-section of the conductor, but has a tendency to travel closer and closer to the surface of the wire as the frequency is increased. This is known as the *skin effect*.

The actual current-carrying portion of the wire is decreased, therefore, and the resistance is increased. This effect becomes even more pronounced in square or rectangular conductors because the principal path of current flow tends to work outwardly toward the four edges of the wire.

Examination of the equation for *Q* may give rise to the thought that even though the resistance becomes greater with frequency, the inductive reactance does likewise, and that the *Q* might be a constant. In actual practice, however, the resistance usually increases more rapidly with frequency than does the reactance, with the result that *Q* normally decreases with increasing frequency.

Parallel Resonance

In radio circuits, parallel resonance is more frequently encountered than series resonance; in fact, it is the basic foundation of receiver and transmitter circuit operation. A circuit is shown in figure 21.

The "Tank" Circuit. In this circuit, as contrasted with a circuit for series resonance, *L* (inductance) and *C* (capacitance) are connected in *parallel*, yet the *combination* can be considered to be in series with the remainder of the circuit. This combination of *L*

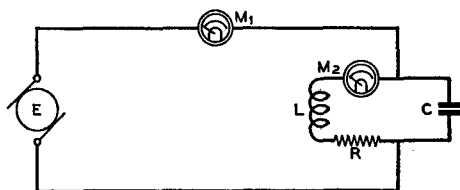

Figure 21.

The parallel resonant tank circuit. L and C comprise the reactive elements of the tank and R indicates the initial r.f. resistance of the components. M_1 indicates what is called the "line current" or the current that keeps the tank in a state of oscillation. M_2 indicates the "tank current" or the amount of current circulating through the elements of the tank.

and C, in conjunction with R, the resistance which is principally included in L, is sometimes called a *tank* circuit because it effectively functions as a storage tank when incorporated in vacuum tube circuits.

Contrasted with series resonance, there are two kinds of current which must be considered in a parallel resonant circuit: (1) the line current, as read on the indicating meter M_1 , (2) the circulating current which flows within the parallel L-C-R portion of the circuit. See figure 21.

At the resonant frequency, the line current (as read on the meter M_1) will drop to a very low value although the circulating current in the L-C circuit may be quite large. It is this line current that is read by the milliammeter in the plate circuit of an amplifier or oscillator stage of a radio transmitter, and it is because of this that the meter shows a sudden *dip* as the circuit is tuned through its resonant frequency. The current is, therefore, a minimum when a parallel resonant circuit is tuned to resonance, although the *impedance* is a *maximum* at this same point. It is interesting to note that the parallel resonant circuit acts in a distinctly opposite manner to that of a series resonant circuit, in which the current is at a maximum and the impedance is minimum at resonance. It is for this reason that in a parallel resonant circuit the principal consideration is one of impedance rather than current. It is also significant that the *impedance* curve for *parallel* circuits is very nearly identical to that of the *current* curve for *series* resonance. The impedance at resonance is expressed as:

$$Z = \frac{(2\pi fL)^2}{R}$$

where Z = impedance in ohms,
L = inductance in henrys,
f = frequency in cycles,
R = resistance in ohms.

Or, impedance can be expressed as a function of Q as:

$$Z = 2\pi fL \cdot Q$$

showing that the impedance of a circuit is directly proportional to its Q at resonance.

The curves illustrated in figure 20 can be applied to parallel resonance in addition to the purpose for which they are illustrated.

Reference to the impedance curve will show that the effect of adding resistance to the circuit will result in both a broadening out and a lowering of the peak of the curve. Since the voltage of the circuit is directly proportional to the impedance, and since it is this voltage that is applied to the grid of the vacuum tube in a detector or amplifier circuit, the impedance curve must have a sharp peak in order for the circuit to be *selective*. If the curve is broadtopped in shape, both the desired signal and the interfering signals at close proximity to resonance will give nearly equal voltages on the grid of the tube, and the circuit will then be *non-selective*; i.e., it will tune broadly.

Effect of L/C Ratio in Parallel Circuits.

In order that the highest possible voltage can be developed across a parallel resonant circuit, the impedance of this circuit must be very high. The impedance will be greater when the ratio of inductance-to-capacitance is great, that is, when L is large as compared with C. When the resistance of the circuit is very low, X_L will equal X_C at resonance and of course, there are innumerable ratios of L and C that will have *equal* reactance, at a given resonant frequency, exactly as is the case in a series resonant circuit. Contrasted with the necessity for a high L/C ratio for high *impedance*, the capacity for maximum *selectivity* must be *high* and the *inductance low*. While such a ratio will result in lower *gain*, it will offer greater *rejectivity* to signals adjacent to the resonant signal.

In practice, where a certain value of inductance is tuned by a variable capacitance over a fairly wide range in frequency, the L/C ratio will be small at the lowest frequency and large at the high-frequency end. The circuit, therefore, will have unequal selectivity at the two ends of the band of frequencies which is being tuned. At the low-frequency end of the tuning band, where the capacitance predominates, the selectivity will be greater and the gain less than at the high-frequency end, where the opposite condition holds true. Increasing the Q of the circuit (lowering the series resistance) will obviously increase *both* the selectivity and gain.

Circulating Tank Current at Resonance.

The Q of a circuit has a definite bearing on

the circulating tank current at resonance. This tank current is very nearly the value of the line current multiplied by the circuit Q . For example: an r.f. line current of 0.050 amperes, with a circuit Q of 100, will give a circulating tank current of approximately 5 amperes. From this it can be seen that the inductance and connecting wires in a circuit with a high Q must be of very low resistance, particularly in the case of high power transmitters, if heat losses are to be held to a minimum.

Effect of Coupling on Impedance. If a parallel resonant circuit is coupled to another circuit, such as an antenna output circuit, the impedance of the parallel circuit is decreased as the coupling becomes closer. The effect of closer (tighter) coupling is the same as though an actual resistance were added to the parallel circuit. The resistance thus coupled into the tank circuit can be considered as being *reflected* from the output or load circuit to the driver circuit.

If the load across the parallel resonant tank circuit is purely resistive, just as it might be if a resistor were shunted across part of the tank inductance, the load will not disturb the resonant setting. If, on the other hand, the load is reactive, as it could be with too-long or too-short antenna for the resonant frequency, the setting of the tank tuning condenser will have to be changed in order to restore resonance.

Tank Circuit Flywheel Effect. When the plate circuit of a class B or class C operated tube (defined in the following chapter) is connected to a parallel resonant circuit, the plate current serves to maintain this L/C circuit in a state of oscillation. If an initial impulse is applied across the terminals of a parallel resonant circuit, the condenser will become charged when one set of plates assumes a positive polarity, the other set a negative polarity. The condenser will then discharge through the inductance; the current thus flowing will cut across the turns of the inductance and cause a counter e.m.f. to be set up, charging the condenser in the opposite direction.

In this manner, an alternating current is set up within the L/C circuit and the oscillation would continue indefinitely with the condenser charging, discharging and charging again if it were not for the fact that the circuit possesses some resistance. The effect of this resistance is to dissipate some energy each time the current flows from inductance to condenser and back, so that the amplitude of the oscillation grows weaker and weaker, eventually dying out completely.

The frequency of the initial oscillation is dependent upon the L/C constants of the circuit. If energy is applied in short spurts or pushes at just the right moments, the L/C circuit can be maintained in a constant oscillatory state. The plate current pulses from class B and class C amplifiers supply just the desired kind of kicks.

Whereas the class B plate current pulses supply a kick for a longer period, the short pulses from the class C amplifier give a pulse of very high amplitude, thus being even more effective in maintaining oscillation. So it is that the positive half cycle in the tank circuit will be reinforced by a plate current kick, but since the plate current of the tube only flows during a half cycle or less, the *missing* half cycle in the tank circuit must be supplied by the discharge of the condenser.

Since the amplitude of this half cycle will depend upon the charge on the plates of the condenser, and since this in turn will depend upon the capacitance, the value of capacitance in use is very important. Particularly is this true if a distorted wave shape is to be avoided, as would be the case when a transmitter is being modulated. The foregoing applies particularly to single-ended amplifiers. If push-pull were employed, the negative half-cycle would secure an additional kick, thereby greatly lessening the necessity of the use of higher C in the L/C circuit.

Impedance Matching: Impedance, Voltage and Turns Ratio. A fundamental law of electricity is that the maximum transfer of energy results when the impedance of the load is equal to the impedance of the driver. Although this law holds true, it is not necessarily a desirable one for every condition or purpose. In many cases where a vacuum tube works into a parallel resonant circuit load, it is desirable to have the load impedance considerably higher than the tube plate impedance, so the maximum power will be dissipated by the load rather than in the tube. On the other hand, one of the notable conditions for which the law holds true is in the matching of transmission lines to an antenna impedance.

Often a vacuum tube circuit requires that the plate impedance of a driver circuit be matched to the grid impedance of the tube being driven. When the driven tube operates in such a condition that it draws grid current, such as in all transmitter r.f. amplifier circuits, the grid impedance may well be lower than the plate tank impedance of the driver stage. In this case it becomes necessary to tap down on the driver tank coil in order to select the proper number of turns that will

give the desired impedance. If the desired working load impedance of the driver stage is 10,000 ohms, for example, and if the tank coil has 20 turns, the grid impedance of the driven stage being 5000 ohms, it is evident that there will be required a step-down im-

pedance ratio of $\frac{10,000}{5000}$ or 2-to-1. This im-

pedance value is *not* secured when the driver inductance is tapped at the center. It is of importance to stress the fact that the impedance is decreased *four times* when the number of turns on the tank coil is *halved*. The following equations show this fact:

$$\frac{N_1}{N_2} = \sqrt{\frac{Z_1}{Z_2}} \quad \text{or} \quad \frac{N_1^2}{N_2^2} = \frac{Z_1}{Z_2}$$

where $\frac{N_1}{N_2}$ = turns ratio,

$$\frac{Z_1}{Z_2} = \text{impedance ratio}$$

In the foregoing example, a step-down impedance ratio of 2-to-1 would require a turns step-down ratio of the square root of the impedance or 1.41. Therefore, if the inductance has 20 turns, a tap would be taken on the sixth turn down from the hot end or 14 turns up from the cold end. This is arrived at by taking the resultant for the turns ratio, i.e., 1.41, and then dividing it into the total number of turns, as follows:

$$\frac{20}{1.41} = (14 \text{ approx.})$$

Either an impedance step-up or step-down ratio can be secured from a parallel resonant circuit. One type of antenna impedance matching device utilizes this principle. Here, however, two condensers are effectively in series across the inductance; one has quite a high capacitance (500 $\mu\text{mfd.}$), the other is a conventional size condenser used principally to restore resonance. The theory of the device is simply that the impedance is proportional to the reactances of the condensers and, by changing the ratio of the two, the antenna is effectively connected into the tank circuit at impedance points which reach higher or lower values at the ratio of the condensers is changed.

In practice, however, it is usually necessary to change the value of inductance in order to maintain resonance while still correctly matching it to the antenna or feeder.

This method is discussed at greater length in *Chapter 20*.

As the impedance step-down ratio becomes larger, the voltage step-down becomes correspondingly great. Such a condition takes place when a resonant circuit is tapped down for reasons of impedance matching; the voltage will be stepped down in direct proportion to the turn step-down ratio. The reverse holds true for step-up ratios. As the step-up ratio is increased, the voltage is increased.

Transformers

When two coils are placed in such inductive relation to each other that the lines of force from one cut across the turns of the other and induce a voltage in so doing, the combination can be called a *transformer*. The name is derived from the fact that energy is transformed from one coil into another. The inductance in which the original flux is produced is called the *primary*; the inductance which receives the induced voltage is called the *secondary*. In a radio receiver power transformer, for example, the coil through which the 110-volt a.c. passes is the *primary*, and the coil from which a higher or lower voltage than the a.c. line potential is obtained is the *secondary*.

Transformers can have either air or magnetic cores, depending upon whether they are to be operated at radio or audio frequencies. The reader should thoroughly impress upon his mind the fact that current can be transferred from one circuit to another *only* if the primary current is changing or alternating. From this it can be seen that a power transformer cannot possibly function as such when the primary is supplied with non-pulsating d.c.

A power transformer usually has a magnetic core which consists of laminations of iron, built up into a square or rectangular form, with a center opening or window. The secondary windings may be several in number, each perhaps delivering a different voltage. The secondary voltages will be proportional to the number of turns and to the primary voltage.

If a primary winding has an a.c. potential of 110 volts applied to 220 turns of wire on the primary, it is evident that this winding will have two turns per volt. A secondary winding of 10 turns, wound on an adjacent leg of the transformer core, would have a potential of 5 volts. If the secondary winding has 500 turns, the potential would be 250 volts, etc. Thus, a transformer can be designed to have either a step-up or step-down ratio, or both simultaneously. The same ap-

plies to air core transformers for radio-frequency circuits.

Transformer Action. Transformers are used in alternating current circuits to transfer power at one voltage and impedance to another circuit at another voltage and impedance. There are three main classifications of transformers: those made for use in power-frequency circuits (25, 50, and 60 cycles), those made for use at radio frequencies, and those made for audio-frequency applications. Power transformers will be discussed in the section devoted to *Power Supplies*, and r.f. transformers are analyzed later on in this chapter; a few of the pertinent facts concerning audio transformers will be covered in the following paragraphs.

Impedance Matching in Audio Circuits. In most audio applications it will be the function of the audio transformer to match the impedance of the plate circuit of a vacuum-tube amplifier to a load circuit of a different impedance. The information given under the paragraph headed *Impedance Matching* is very easily applied to this type of calculation.

In all audio-frequency circuit applications, it is only necessary to refer to the *tube tables* in this book in order to find the recommended load impedance for a given tube and a given set of operating conditions. For example, the table shows that a type 42 pentode tube requires a load impedance of 7000 ohms. Audio transformers are always rated for both their primary and secondary impedance, which means that the primary impedance will be of the rated value *only* when the secondary is terminated in its rated impedance.

If a 7000-ohm plate load is to work into a 7-ohm loudspeaker voice coil, the impedance ratio of the transformer would be

$$\frac{7000}{7} = 1000\text{-to-}1. \text{ Hence, the turns-ratio}$$

will be the square root of 1000 or 31.6. This does not mean that the primary will have only 31.6 turns of wire and only one turn on the secondary. The primary must have a certain *inductance* in order to offer a high impedance to the lower audio frequencies. Consequently, it must have a large number of turns of wire in the primary winding. The *ratio* of total primary turns to total secondary turns must remain constant, regardless of the number of turns in the primary if the correct primary impedance is to be maintained.

To summarize, a certain transformer will have a certain impedance ratio (determined by the square of the turns ratio) which will remain constant. If the transformer is term-

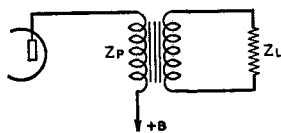

Figure 22.

The reflected impedance Z_P varies directly in proportion to Z_L and in proportion to the square of the turns ratio.

inated with an impedance or resistance *lower* than the original rated value, the reflected impedance on the primary will also be lower than the rated value. If the transformer is terminated in an impedance *higher* than rated, the reflected primary impedance will be higher.

For push-pull amplifiers the recommended primary impedance is stated as some certain value, *plate to plate*; this refers to the impedance of the total winding without consideration of the center tap. The reflected impedance across the total primary will follow the same rules as previously given for single-ended stages.

The voltage relationship in primary and secondary is the same as the turns ratio. For a step-down turns ratio of 10-to-1, the corresponding *voltage* step-down would be 10-to-1 though the *impedance* ratio would be 100-to-1. This information is useful when it is desired to convert the turns ratios given on certain types of driver transformers into impedance ratios.

The same type of reasoning and subsequent calculation would be used in determining the turns ratio for a modulation transformer to couple a certain pair of class-B modulators to a class-C final amplifier. The recommended plate-to-plate load impedance for the modulator tubes can be obtained from the tube tables given later on. The final amplifier load resistance is then determined by dividing its plate voltage by the plate current at which it is to operate. The turns ratio of the modulation transformer is then

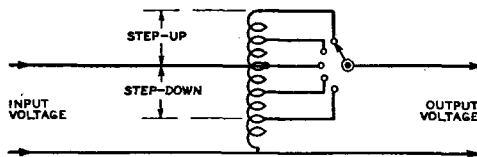

Figure 23.

Schematic diagram of an auto-transformer showing the method of connecting it to the line and to the load.

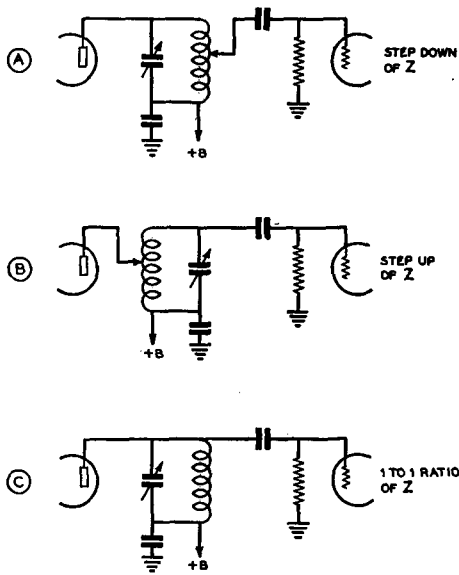

Figure 24.

Impedance step-up and step-down may be obtained by utilizing the plate tank circuit of a vacuum tube as an auto-transformer.

equal to the square root of the ratio between the modulator load impedance and the amplifier load resistance; the transformer may be either step-up or step-down as the case may be.

The Auto Transformer. The type of transformer in figure 23 when wound with heavy wire and over an iron core is a common device in primary power circuits for the purpose of increasing or decreasing the line voltage. In effect, it is merely a continuous winding with taps taken at various points along the winding, the input voltage being applied to the bottom and also to one tap on the winding. If the output is taken from this same tap, the voltage ratio will be 1-to-1; i.e., the input voltage will be the same as the output voltage. On the other hand, if the output tap is moved down toward the common terminal, there will be a step-down in the turns ratio with a consequent step-down in voltage.

The opposite holds true if the output terminal is moved upward from the middle input terminal; there will be a voltage step-up in this case. The initial setting of the middle input tap is chosen so that the number of turns will have sufficient reactance to keep the no-load primary current at a reasonably low value.

In the same manner as voltage is stepped up and down by changing the number of

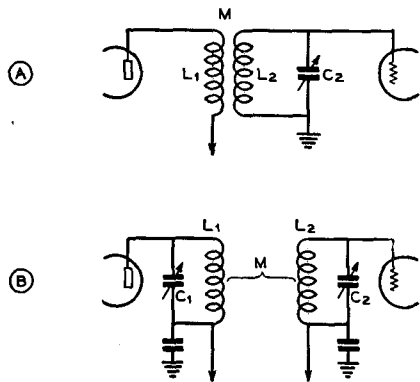

Figure 25.

Two commonly used types of inductive coupling between radio-frequency circuits.

turns in a winding, so can impedance be stepped up or down. Figure 24A shows an application of this principle as applied to a vacuum tube circuit which couples one circuit to another.

Assuming that the grid impedance may be of a lower value than the plate tank impedance of the preceding stage, a step-down ratio will be necessary in order to give maximum transfer of energy. In B of figure 24, the grid impedance is very high as compared with the tank impedance of the driver stage, and thus there is required a step-up ratio to the grid. The driver plate is tapped down on its plate tank coil in order to make this impedance step-up possible. A driver tube with very low plate impedance must be used if a good order of plate efficiency is to be realized.

In C of figure 24, the grid impedance very closely approximates the plate impedance and this connection is used when no transformation is required. The grid and plate impedances are not generally known in many practical cases; hence, the adjustments are made on the basis of maximum grid drive consistent with maximum safe input to the driver stage.

Inductive Coupling—The Radio-Frequency Transformer. Inductive coupling is often used when two circuits are to be coupled. This method of coupling is shown in figures 25A and 25B.

The two inductances are placed in such inductive relation to each other that the lines of force from the primary coil cut across the turns of the secondary coil, thereby inducing a voltage in the secondary. As in the case of capacitive coupling, impedance transformation here again becomes of importance. If two parallel tuned circuits are coupled very closely together, the circuits can in reality be

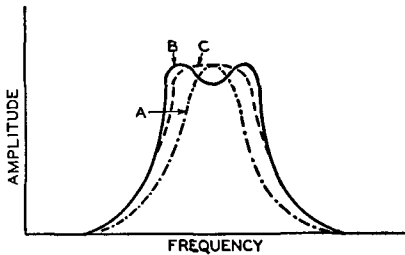

Figure 26.

Effect of coupling between circuits upon the resonance curve. Curve A indicates the curve when the circuits are under-coupled, B is the curve resulting from over-coupling, and C is the curve resulting from an intermediate value of coupling. Although the output amplitude would not be the same in all three cases, the curves have been drawn to the same maximum to illustrate more clearly their relative shapes.

overcoupled. This is illustrated by the curve in figure 26.

The dotted line curve A is the original curve or that of the primary coil *alone*. Curve B shows what takes place when two circuits are overcoupled; the resonance curve will have a definite dip on the peak, or a double hump. This principle of overcoupling is advantageously utilized in bandpass circuits where, as shown in C, the coupling is adjusted to such a value as to reduce the peak of the curve to a virtual flat top, with no dip in the center as in B.

Some undesirable capacitive coupling will result when circuits are closely or tightly coupled; if this capacitive coupling is appreciable, the tuning of the circuits will be affected. The amount of capacitive coupling can be reduced by so arranging the physical shape of the inductances as to enable only a minimum surface of one to be presented to the other.

Another method of accomplishing the same purpose is by electrical means. A curtain of closely-spaced parallel wires or bars, connected together only at one end, and with this end connected to ground, will allow electromagnetic coupling but not electrostatic coupling. Such a device is called a *Faraday screen or shield*.

Link Coupling. Still another method of decreasing capacitive coupling is by means of a *coupling link* circuit between two parallel resonant circuits. The capacity of the coupling link, with its one or two turns, is so small as to be negligible. Also, one side of the link is often grounded to reduce further any capacitive coupling that may exist.

Link coupling is widely used in transmitter circuits because it adapts itself so universally

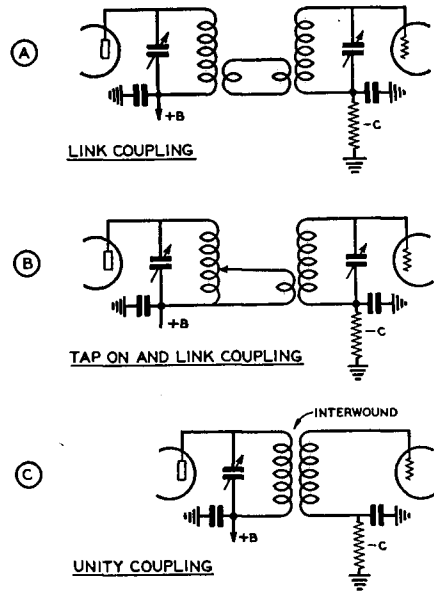

Figure 27.

Two types of link (inductive) coupling and (C) unity coupling.

and eliminates the need of a radio-frequency choke, thereby reducing a source of loss. Link coupling is very simple; it is diagrammed in A and B of figure 27.

In A of figure 27, there is an impedance step-down from the primary coil to the link circuit. This means that the line which connects the two links or loops will have a low impedance and therefore can be carried over a considerable distance without introduction of appreciable loss. A similar link or loop is at the output end of the line; this loop is coupled to the grid tank of the driven stage.

Still another link coupling method is shown in B of figure 27. It is similar to that of A, with the exception that the primary line is tapped on the coil, rather than being terminated in a link or loop.

Unity Coupling. Another commonly used type of coupling is that known as *unity coupling*, by reason of the fact that the turns ratio between primary and secondary is one-to-one. This method of coupling is illustrated in C of figure 27. Only one of the windings is tuned although the interwinding of the two coils gives an effect in the untuned winding as though it were actually tuned with a condenser.

Unity coupling is used in some types of ultra-high-frequency circuits although the mechanical considerations are somewhat difficult. The secondary, when it serves as the

grid coil, is placed inside of a copper tubing coil; the latter serves as the primary or plate coil.

Conduction of an Electric Current

So far this chapter has dealt only with the conduction of current by a stream of electrons through a conductor or by electrostatic coupling through a capacitor. While this is the most common method of transmission, there are other types of conduction which are equally important in their respective branches of the field. An electric current may also be transmitted by the motion of minute particles of matter, by the motion of charged atoms called *ions*, and by a stream of electrons in a vacuum.

The carrying of current by charged particles, such as bits of dust, is only of academic interest in radio. However, there is a commercial process (called the Cottrell process) which uses this type of conduction in industrial dust precipitation. A highly charged wire inside a grounded metal chamber is placed so that the dust-laden flue gases from certain industrial processes (usually metallurgic refining) must pass through the chamber. The dust particles are first attracted to the wire; there they attain a high electric charge which causes them to be attracted to the sides of the chamber where they are precipitated and subsequently collected. A small electric current between the center electrode and the chamber is the result of the carrying of the charges by the dust particles.

Conduction by Ions. When a high enough voltage is placed between two terminals in air or any other gas, that gas will break down suddenly, the resistance between the two points will drop from an extremely high value to a few hundredths or thousandths of ohms, and a comparatively large electric current will flow to the accompaniment of an amount of visible light either as a flash, an arc, a spark, or a colored discharge such as is found in the "neon" sign. This type of conduction is due to gas ions which are generated when the electric stress between the two points becomes so great that electrons are torn from the molecules of the gas with the production of a quantity of positively charged gas ions and negative electrons. The breakdown voltage for a particular gas is dependent upon the pressure, the spacing of the electrodes, and the type of electrodes.

Lightning, tank condenser flashovers, and ignition sparks in an automobile are such discharges that occur at atmospheric pressure or above. However, the pressure of the gas is usually reduced to facilitate the ease of break-

down of the gas as in the "neon" sign, mercury-vapor lamp, or voltage regulator tubes such as the VR-150-30. If a heated filament is used as one electrode in the discharge chamber, the breakdown voltage is further reduced to a value called the *ionization potential* of the gas. This principle is used in the 866, the 83, and other mercury-vapor rectifiers. Through the use of the heated cathode the break-down potential is reduced from about 10,000 volts to approximately 15 volts and the conduction of electric current is made unidirectional, enabling the discharge chamber to be used as a rectifier. The applications of the principle of ionic conduction in vacuum tubes (along with discussion of electronic conduction) will be covered in more detail in the chapter devoted to *Vacuum Tube Theory*.

The emission of colored light which accompanies an electric discharge through a gas is due to the re-combination of the ionized gas molecules and the free electrons to form neutral gas molecules. There is a definite color spectrum which is characteristic of every gas—and for that matter for every element when it is in the gaseous state. For neon this color is orange-red, for mercury it is blue-violet, for sodium, almost pure yellow—and so on through the list of the elements. This principle is used in the spectroscopic identification of elements by their characteristic lines in the spectrum (called Fraunhofer lines).

Electrolytic Conduction. Nearly all inorganic chemical compounds (and a few organic ones of certain molecular structure) when dissolved in water undergo a chemical-electrical change known as *electrolytic dissociation* which results in the production of ions similar in certain properties to those formed as a result of the electric breakdown of a gas. For example, when sodium chloride or table salt is dissolved in water a certain percentage of it ionizes or breaks down into positively charged sodium ions, or sodium atoms with a deficiency of one electron, and negatively charged chloride ions, or chlorine atoms with one excess electron. Similarly, sodium hydroxide disassociates into positive sodium ions and negative hydroxyl ions—sulfuric acid into positive hydrogen ions and negative sulfate ions.

This solution of an ionized compound and water renders the aqueous solution a conductor of electricity. (Water in the pure form is a good insulator.) The conductivity of the solution is proportional to the mobility of the ions and to the quantity of them available in the solution. Maximum conductivity is had not when there is a maximum of the

compound in solution but rather when there is a maximum of ions in solution; this condition is ordinarily obtained when neither concentrated nor dilute but about midway between. Maximum conductivity in a sulfuric acid solution as used in storage batteries is obtained when there is about 30 per cent by weight of the acid in solution in the water. It is for this reason that acid of about 30 per cent concentration is used as an electrolyte in storage batteries.

Conduction of electricity through an *electrolyte*, as a conducting solution is called, is made possible by the mobility of the charged ions in solution. When a positively and a negatively charged wire are placed in an electrolyte the negative ions are attracted to the positive wire and the positive ions are attracted to the negative wire. As the ions reach the wire carrying the charge opposite to their own, their excess or their deficiency of electrons is neutralized by the respective deficiency or excess of electrons on the wire and the ion changes from the ionic to the atomic or molecular state. If the ion happened to be that of a metal such as copper, copper will be *plated* upon the negative electrode that had been placed into the solution; if the negative ion was that of chlorine (the chloride ion) then chlorine in the gaseous form will appear at the positive electrode. The conduction of an electric current through an electrolyte always results in a chemical change in the electrolyte. This fact is employed commercially in electroplating and electrolytic refining.

The Primary Cell. If two dissimilar metals are placed in an electrolyte a potential difference will appear between the two materials. This postulate is employed commercially in the primary cell or "dry cell" as it is somewhat incorrectly called.

The operation of the primary cell depends upon the differences in the two electrochemical constants for the materials used as the electrodes. With the zinc and carbon used in the dry cell (with a paste containing ammonium chloride as the electrolyte) the potential is 1.53 volts. With other electrolytes and electrodes the potential output of the cell varies from 0.7 to 2.5 volts.

When current is taken from a primary cell the negative electrode (usually the zinc container) dissolves in the electrolyte with the production of hydrogen gas. If only the positive and the negative electrodes and the electrolyte were contained in the cell, this hydrogen gas would collect as a film on the surface of the negative electrode. When this film does form, the internal resistance of the

cell increases due to the insulating properties of the film of gas. A cell is said to have become "polarized" when this has taken place. To reduce this effect an oxidizing agent called a "depolarizer" (manganese dioxide in the case of the dry cell) is incorporated into the electrolyte. If current is taken from the cell at a reasonable rate the depolarizer oxidizes the hydrogen into water as fast as it is formed. This formation of water as a result of the normal operation of the cell is one of the reasons that a dry cell "sweats" when it is approaching the end of its useful life.

Dry cells and batteries of them are very commonly employed in portable radio equipment as both filament and plate supply and frequently as plate supply only at locations where there is no source of alternating current. Through recent improvements in cell manufacture and in the design of batteries of these cells it is possible to make very lightweight sources of a quite reasonable amount of power. 45-volt B batteries are available ranging in weight from 16 pounds down to about 2 ounces. The large sizes will stand current drain up to about 75 ma. for a few hundred hours while the smallest sizes will last only a few hours with a drain of one or two milliamperes. Medium sizes capable of producing 8 to 10 ma. for one-hundred hours or so are commonly used in radio-controlled model aircraft and in the new portable broadcast receivers. The average weight of a 45-volt unit in this classification is about 10 ounces.

Dry cells are also commonly used as filament and plate supplies in meteorological balloons (the ultra-light types, usually), for ignition purposes on small motors, in some telephone and telegraph systems, in hearing aids, and as sources of grid-bias voltage in amateur transmitters.

The Secondary Cell—Storage Batteries. The primary cell, as described in the preceding paragraphs, produces its voltage as a result of chemical action of the electrolyte on one of the elements. When the material comprising the active element is used up, the cell is no longer useful and must be discarded. The secondary cell, on the other hand, is capable of being recharged to its original energy content when it has been depleted.

There are two common types of secondary cells: the *Edison cell*, which uses iron as the negative pole and nickel oxide as the positive in a 20 per cent solution of potassium hydroxide as the electrolyte; and the *lead cell*, which uses lead as the negative pole and lead dioxide as the positive pole in an electrolyte of 30 per cent sulfuric acid.

CHAPTER THREE

Theory and Operation of Vacuum Tubes

Thomas Edison is credited with the discovery that if an additional wire or terminal were placed inside an incandescent lamp and the filament lighted, the terminal would acquire a negative charge of electricity. J. A. Fleming began the study of the *Edison Effect* in 1895, and as a result of his findings, in 1904 he patented the two-electrode tube or diode which became known as the Fleming valve. Then, in 1906, Lee de Forest discovered that a third element could be placed between the cathode and plate to control the flow of energy between them. This third element was called the *grid* and its insertion into the diode resulted in the most versatile of vacuum tubes, the *triode*.

Thermionic Emission. The original Edison discovery was that a heated filament would give off electrons which would be attracted to a cold plate in the same evacuated chamber. It was later discovered that if the plate were charged positively with respect to the filament, a large number of the emitted electrons would be attracted to the plate. This discovery, coupled with that wherein it was found a grid could be placed between the two elements to control the electron flow between them, forms the basis for the modern vacuum tube.

The free electrons in a metallic wire are continually in motion at all temperatures, but at all ordinary atmospheric temperatures these electrons do not have sufficient velocity to penetrate the surface of the wire. However, as the wire is heated the velocities of the free electrons increase until at a certain temperature determined by the character of the wire a measurable amount of them are able to penetrate the surface of the wire and be emitted into the surrounding vacuum. As the temperature of the filament is raised above this critical temperature the emission of electrons increases rapidly.

Types of Emitters

Emitters as used in present-day vacuum tubes may be classed into two groups: the directly heated or filament type, and the indirectly heated or heater-cathode type. Directly heated emitters may be further subdivided into three important groups, all of which are important and commonly used in modern tubes. These classifications are: the pure tungsten filament, the thoriated-tungsten filament, and the oxide-coated filament.

The Pure Tungsten Filament. Pure tungsten wire was used as the filament in nearly all the earlier transmitting and receiving tubes. However, the thermionic efficiency of tungsten wire as an emitter (the number of milliamperes emission per watt of filament heating power) is quite low, the filaments become fragile after use, their life is rather short, and they are susceptible to burnout at any time. Pure tungsten filaments must be run at bright white heat (about 2500° Kelvin). For these reasons tungsten filaments have been replaced in all applications where another type of filament could be used. They are, however, still universally employed in most water-cooled tubes and in certain large, high-power air-cooled triodes where another filament type would be unsuitable. Tungsten filaments are the most satisfactory for high-power, high-voltage tubes where the emitter is subjected to positive ion bombardment due to the residual gas content of the tubes. Tungsten is not adversely affected by such bombardment.

The Thoriated-Tungsten Filament. In the course of experiments made upon tungsten emitters it was found that filaments made from tungsten having a small amount of thoria (thorium oxide) as an impurity had much greater emission than those made from

the pure metal. Subsequent improvements have resulted in the highly efficient carburized thoriated-tungsten filament as used in virtually all medium-power transmitting tubes in use today.

Thoriated-tungsten emitters consist of a tungsten wire containing about one per cent thoria. The new filament is first carburized by heating it to a high temperature in an atmosphere containing a hydrocarbon at reduced pressure. Then the envelope is highly evacuated and the filament is flashed for a minute or two at about 2600° K before being burned at 2200° K for a longer period of time. The flashing causes some of the thoria to be reduced by the carbon to metallic thorium. The activating at a lower temperature allows the thorium to diffuse to the surface of the wire to form a layer of the metal a molecule thick. It is this single-molecule layer of thorium which reduces the work function of the tungsten filament to such a value that the electrons will be emitted from a thoriated filament thousands of times more rapidly than from a pure tungsten filament *operated at the same temperature.*

The carburization of the tungsten surface seems to form a layer of tungsten carbide which holds the thorium layer much more firmly than the plain tungsten surface. This allows the filament to be operated at a higher temperature, with consequent greater emission, for the same amount of thorium evaporation. Thorium evaporation from the surface is a natural consequence of the operation of the thoriated-tungsten filament. The carburized layer on the tungsten wire plays another role in acting as a reducing agent to produce new thorium from the thoria to replace that lost by evaporation. This new thorium continually diffuses to the surface during the normal operation of the filament.

One thing to remember about any type of filament, particularly the thoriated type, is that the emitter deteriorates practically as fast when "standing by" (no plate current) as it does with any normal amount of emission load. However, a thoriated filament may be either temporarily or permanently damaged by a heavy overload which may strip the surface emitting layer of thorium from the filament.

Reactivating Thoriated-Tungsten Filaments. Thoriated-tungsten filaments (and *only* thoriated-tungsten filaments) which have gone "flat" as a result of insufficient filament voltage, a severe temporary overload, a less severe extended overload, or even normal operation may quite frequently be reactivated to their original characteristics

by a process similar to that of the original activation. However, only filaments which have been made by a reputable manufacturer and which have not approached too close to the end of their useful life may be successfully reactivated. The filament found in certain makes of tubes may often be reactivated three or four times before the filament will cease to operate as a thoriated emitter.

The actual process of reactivation is simple enough and only requires a filament transformer with taps allowing voltage up to about 25 volts or so. The tube which has gone flat is placed in a socket to which only the two filament wires have been connected. The filament is then "flashed" for about 20 to 40 seconds at from 1½ to 2 times normal rated voltage. The filament will become extremely bright during this time and, if there is still some thoria left in the tungsten and if the tube didn't originally fail as a result of an air leak, some of this thoria will be reduced to metallic thorium. The filament is then burned at 15 to 25 per cent overvoltage for from 30 minutes to three to four hours to bring this new thorium to the surface.

The tube should then be tested to see if it shows signs of renewed life. If it does, but is still weak, the burning process should be continued at about 10 to 15 per cent overvoltage for a few more hours. This should bring it back almost to normal. If the tube checked still very low after the first attempt at reactivation the complete process can be repeated as a last effort.

Thoriated-tungsten filaments are operated at about 1900° K or at a bright yellow heat. A burnout at normal filament voltage is almost an unheard of occurrence. The ratings placed upon tubes by the manufacturers are figured for a life expectancy of 1000 hours. Certain types of tubes may give much longer life than this but the average transmitting tube will give from 1000 to 5000 hours of useful life.

The Oxide-Coated Filament

The most *efficient* of all modern filaments is the oxide-coated type which consists of a mixture of barium and strontium oxides coated upon a wire or strip usually consisting of a nickel alloy. This type of filament operates at a dull-red to orange-red temperature (1050° to 1170° K) at which temperature it will emit large quantities of electrons. The oxide-coated filament is somewhat more efficient than the thoriated-tungsten type in small sizes and it is considerably less expensive to manufacture. For this reason all

receiving tubes and quite a number of the low-powered transmitting tubes use the oxide-coated filament. Another advantage of the oxide-coated emitter is its extremely long life—the average tube can be expected to run from 3000 to 5000 hours, and when loaded very lightly tubes of this type have been known to give 50,000 hours of life before their characteristics changed to any great extent.

The oxide-coated filament does have the disadvantage, however, that it is unsuitable for use in tubes which must withstand more than about 600 volts of plate potential. Some years back transmitting tubes for operation up to 2000 volts were made with oxide-coated filaments but they have been discontinued. Much more satisfactory operation is obtainable at medium plate potentials with thoriated filaments.

Oxide filaments are unsatisfactory for use at high plate voltages because (1) their activity is seriously impaired by the high temperature necessary to bombard the high-voltage tubes and, (2) the positive ion bombardment which takes place even in the best evacuated high-voltage tube causes destruction of the oxide layer on the surface of the filament.

Oxide-coated filaments operate by virtue of a mono-molecular layer of alkaline-earth metal (barium and strontium) which forms on the surface of the oxide coating. Such filaments do not require reactivation since there is always sufficient reduction of the oxides and diffusion of the metals to the surface of the filament to more than meet the emission needs of the cathode.

Indirectly Heated Filaments— The Heater Cathode

The heater type cathode was developed as a result of the requirement for a type of emitter which could be operated from alternating current and yet would not introduce a.c. ripple modulation even when used in low-level stages. It consists essentially of a small nickel-alloy cylinder with a coating of strontium and barium oxides on its surface similar to that used on the oxide-coated filament. Inside the cylinder is an insulated heater element consisting usually of a double spiral of tungsten wire. The heater may operate on any voltage from 2 to 117 volts although 6.3 is by far the most common value. The heater is operated at quite a high temperature so that the cathode itself may be brought to operating temperature in a matter of 15 to 30 seconds. Heat coupling between the heater and the cathode is mainly by radia-

tion, although there is some thermal conduction through the insulating coating on the heater wire, as this coating is also in contact with the cathode thimble.

Indirectly heated cathodes are employed in all a.c. operated tubes which are designed to operate at a low level either for r.f. or a.f. use. However, some receiver power tubes use heater cathodes (6L6, 6V6, 6F6, and 6B4G) as do some of the low-power transmitter tubes (802, 807, T21, and RK39). Heater cathodes are employed exclusively when a number of tubes are to be operated in series as in an a.c.-d.c. receiver. A heater cathode is often called a uni-potential cathode because there is no voltage drop along its length as there is in the filament-type cathode.

Types of Vacuum Tubes

If a cathode capable of being heated either indirectly or directly is placed in an evacuated envelope along with a plate, such a two-element vacuum tube is called a diode. The diode is the simplest of all vacuum tubes and is the fundamental type from which all the others are derived; hence, the diode and its characteristics will be discussed first.

Characteristics of the Diode. When the cathode within a diode is heated, it will be found that a few of the electrons leaving the cathode will leave with sufficient velocity to reach the plate. If the plate is electrically connected back to the cathode, the electrons which have had sufficient velocity to arrive at the plate will flow back to the cathode through the external circuit. This small amount of initial plate current is an effect found in all two-element vacuum tubes.

If a battery or other source of d.c. voltage is placed in the external circuit between the plate and cathode so that the battery voltage places a positive potential on the plate, the flow of current from the cathode to plate will be increased. This is due to the strong attraction offered by the positively charged plate for any negatively charged particles. If the positive potential on the plate is increased, the flow of electrons between the cathode and plate will also increase up to the point of *saturation*. Saturation current flows when all of the electrons leaving the cathode are attracted to the plate, and no increase in plate voltage can increase the number of electrons being attracted.

The Space Charge Effect. As a cathode is heated so that it begins to emit, those electrons which have been discharged into the surrounding space form in the immediate

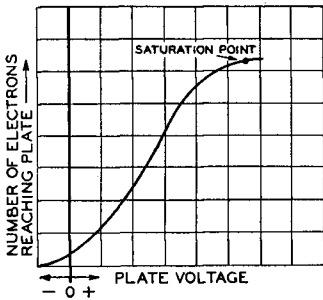

Figure 1.

CURVE SHOWING NUMBER OF ELECTONS REACHING THE PLATE OF A DIODE PLOTTED AS A FUNCTION OF THE PLATE VOLTAGE.

It will be noticed that there is a small flow of plate current even with zero voltage. This initial flow can be stopped by a small negative plate potential. As the plate voltage is increased in a positive direction, the plate current increases approximately as the 3/2 power of the plate voltage until the saturation point is reached. At this point all the electrons being emitted from the cathode are being attracted to the anode.

vicinity of the cathode a negative charge which acts to repel those electrons which normally would be emitted were the charge not present. This cloud of electrons around the cathode is called the *space charge*. The electrons comprising the charge are continuously changing, since those electrons making up the original charge fall back into the cathode and are replaced by others emitted by it.

The effect of the space charge is to make the current through the tube variable with respect to the plate-to-cathode drop across it. As the plate voltage is increased, the positive charge of the plate tends to neutralize the negative space charge in the vicinity of the cathode. This neutralizing action upon the space charge by the increased plate voltage allows a greater number of electrons to be emitted from the cathode which, obviously, causes a greater plate current to flow. When the point is reached at which the space charge around the cathode is neutralized completely, all the electrons that the cathode is capable of emitting are being attracted to the plate and the tube is said to have reached *saturation* plate current as mentioned above.

Insertion of a Grid—The Triode. If an element consisting of a mesh or spiral of wire is inserted concentric with the plate and between the plate and the cathode, such an element will have an effect on the cathode-to-plate current of the tube. The new element is commonly called a grid, and a vacuum

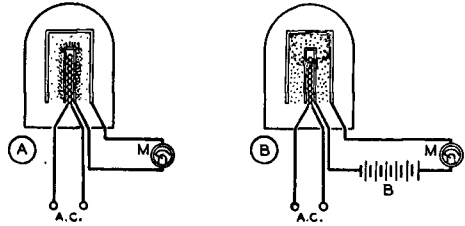

Figure 2.

ILLUSTRATING THE SPACE CHARGE EFFECT IN A DIODE.

(A) shows the space charge existing in the vicinity of the cathode with zero or a small amount of plate voltage. A few high-velocity electrons will reach the plate to give a small plate current even with no plate voltage. (B) shows how the space charge is neutralized and all the electrons emitted by the cathode are attracted to the plate with a battery sufficient to cause saturation plate current.

tube containing a cathode, grid, and plate is commonly called a three-element tube or, more simply, a *triode*.

If this new element through which the electrons must pass in their course from cathode to plate, is made negative with respect to the filament, the charge on this grid will in effect aid the space charge surrounding the cathode and hence will reduce the plate current of the tube. As a matter of fact, if the charge on this grid is made sufficiently negative the space charge will be increased to such an extent that all the electrons leaving the cathode will be repelled back to it and the plate current will be reduced to zero. Any d.c. voltage placed upon a grid (especially so when speaking of a control grid) is called a *bias*. Hence, the smallest negative voltage which causes cutoff of plate current is called the value of *cutoff bias*.

Figure 3 illustrates the manner in which the plate current of a typical triode will vary with different values of grid bias. This shows graphically the cutoff point, the approximately linear relation between grid bias and plate current over the operating range of the tube, and the point of plate current saturation. However, the point of plate current saturation comes at a different position with a triode as compared to a diode. Plate current non-linearity or saturation may begin either at the point where the full emission capabilities of the filament have been reached or at the point where the positive grid voltage begins to approach the positive plate voltage.

This latter point is commonly referred to as the *diode bend* and is caused by the positive voltage of the grid allowing it to rob from the current stream electrons that would normally go to the plate. When the plate

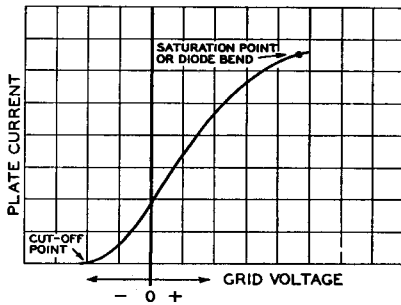

Figure 3.
PLATE CURRENT PLOTTED AGAINST
GRID VOLTAGE, WITH CONSTANT
PLATE VOLTAGE.

For values of grid bias between those which give plate current cutoff and plate current saturation, the value of plate current varies more or less linearly with respect to changes in grid voltage.

voltage is low with respect to that required for full current from the cathode, the diode bend is reached before plate current saturation. When the plate voltage is high, saturation is reached first.

From the above it can be seen that the grid acts as a valve in controlling the electron flow from the cathode to the plate. As long as the grid is kept negative with respect to the cathode, only an extremely small amount of grid energy is required to control a comparatively large amount of plate power. Even if the grid is operated in the positive region a portion of the time, so that it will draw current, the grid energy requirements are still very much less than the energy controlled in the plate circuit. It is for this reason that a vacuum tube is commonly called a *valve* in Britain, Australia, and Canada.

Interelectrode Capacitance. In the preceding chapter it was mentioned that two conductors separated by a dielectric form a *condenser*, or that there is *capacitance* between them. Since the electrodes in a vacuum tube are conductors and they are separated by a dielectric, vacuum, there is capacitance between them. Although the interelectrode capacitances are so small as to be of little consequence in audio-frequency work, they are large enough to be of considerable importance when the tubes are operated at radio frequencies.

Figure 4 shows the interelectrode capacitances in a triode as they appear to a circuit in which the tube is operating. The grid-to-filament (C_{gf}) and plate-to-filament (C_{pf}) capacitances cause no serious disadvantage for ordinary work since they add only a small amount of capacity to the input and output

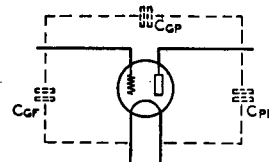

Figure 4.
EFFECTIVE INTERELECTRODE
CAPACITIES WITHIN A TRIODE.

circuits. However, the grid-to-plate capacity (C_{gp}) acts effectively as a small coupling condenser from the output circuit of the tube back to the input circuit. This capacity can cause undesirable effects in the form of regeneration or oscillation in radio-frequency amplifiers. The effect of this capacity can be balanced out by a bridge circuit of capacitances, a process discussed under *Neutralization* in the chapter devoted to *Transmitter Theory*. The quest for a simpler and more easily usable method of eliminating this capacity or its effects led to the development of the screen-grid tube or tetrode.

The Tetrode or Screen-Grid Tube. When another grid is added to a vacuum tube between the control grid and plate, the tube is then called a *tetrode*, meaning that it has four elements. Such tubes are more familiarly known as *screen-grid* tubes since the additional element is called a *screen*. The interposition of this screen between grid and plate serves as an electrostatic shield between these two elements, with the consequence that the grid-to-plate capacitance is reduced. This effect is accomplished by establishing the screen at r.f. ground potential by by-passing it to ground with a fairly large condenser. The grid-plate capacitance is then so small that the amount of feedback voltage from plate to grid is normally insufficient to start oscillation. The advent of the screen-grid tube eliminated the necessity for lossers and neutralization previously required to prevent a triode r.f. amplifier stage from oscillating.

In addition to the shielding effect, the screen grid serves another very useful purpose. Since the screen is maintained at a positive potential, it serves to increase or accelerate the flow of electrons to the plate. There being large openings in the screen mesh, most of the electrons pass through it and on to the plate. Due also to the screen, the plate current is largely independent of plate voltage, thus making for high amplification. When the screen is held at a constant value, it is possible to make radical changes in plate voltage without appreciably affecting the plate current.

Secondary Emission; Pentodes. When the electrons from the cathode travel with sufficient velocity, they dislodge electrons upon striking the plate. This effect of *bombarding* the plate with high velocity electrons, with the consequent dislodgement of other electrons from the plate, is known as *secondary emission*. This effect can cause no particular difficulty in a triode tube because the secondary electrons so emitted are eventually attracted back to the plate. In the screen-grid tube, however, the screen is close to the plate and is maintained at a positive potential. Thus, the screen will attract these electrons that have been knocked from the plate, particularly when the plate voltage falls to a lower value than the screen voltage, with the result that the plate current is lowered and the amplification is decreased.

This effect is eliminated when still another element is added between the screen and plate. This additional element is called a *suppressor*, and tubes in which it is used are called *pentodes*. The suppressor grid is sometimes connected to cathode within the tube, sometimes it is brought out to a connecting pin on the tube base, but in any case it is established negative with respect to the minimum plate voltage. The secondary electrons that would travel to the screen if there were no suppressor are diverted back to the plate. The plate current is, therefore, not reduced and the amplification possibilities are increased.

Pentodes for radio applications are designed so that the suppressor increases the limits to which the plate voltage may swing; therefore the consequent power output and gain can be very great. Pentodes for radio-frequency service function in such a manner that the suppressor allows high voltage gain, at the same time permitting fairly high gain at low plate voltage. This holds true even if the plate voltage is the same or slightly lower than the screen voltage.

Beam Power Tubes. A beam power tube makes use of a new method for suppressing secondary emission. In this tube there are four electrodes: a cathode, a grid, a screen and a plate, so spaced and placed that secondary emission from the plate is suppressed without actual power. Because of the manner in which the electrodes are spaced, the electrons which travel to the plate are slowed down when the plate voltage is low, almost to zero velocity in a certain region between screen and plate. For this reason the electrons form a stationary cloud, a *space charge*. The effect of this space charge is to repel secondary electrons emitted from the plate and thus cause them to return to the plate. In

this way, secondary emission is suppressed.

Another feature of the beam power tube is the low current drawn by the screen. The screen and the grid are spiral wires wound so that each turn in the screen is shaded from the cathode by a grid turn. This alignment of the screen and the grid causes the electrons to travel in sheets between the turns of the screen so that very few of them flow to the screen. Because of the effective suppressor action provided by the space charge, and because of the low current drawn by the screen, the beam power tube has the advantages of high power output, high power sensitivity and high efficiency. The 6L6 is such a beam power tube designed for use in the power amplifier stages of receivers and speech amplifiers or modulators. Larger tubes employing the beam-power principle are being made by various manufacturers for use in the radio-frequency stages of transmitters. These tubes feature extremely high power sensitivity (a very small amount of driving power is required for a large output), good plate efficiency, and freedom from the requirement for neutralization. Notable among these transmitting beam power tubes are the T21 of Taylor, and the 807, 814, and 813 of RCA and G.E.

Television Amplifier Pentodes. There was a need in television work, where extremely wide bands of frequencies must be passed by an amplifier, for vacuum tubes which would give extremely high amplification and still have comparatively low plate impedance and shunt capacitances. This need led to the development of the 1851, 1852, 1853, 1231, etc.—all of which answer this requirement with slight individual variations. Through the use of a large cathode and a very fine mesh grid spaced very close to the cathode, it has been possible to obtain in these pentodes amplification factors of 6000 and above with transconductances of 5000 to 12,000. The true significance of these figures can be grasped after the material in the latter part of this chapter has been studied.

Pentagrid Converters. A pentagrid converter is a multiple grid tube so designed that the functions of superheterodyne oscillator and mixer are combined in one tube. One of the principal advantages of this type of tube in superheterodyne circuits is that the coupling between oscillator and mixer is automatically done; the oscillator elements effectively modulate the electron stream and, in so doing, the conversion conductance is high. The principal disadvantage of these tubes lies in the fact that they are not particularly suited for operation at frequencies

much above 20 Mc. because of difficulties encountered in the oscillator section.

Special Purpose Mixer Tubes. Notable among the special purpose multiple grid tubes is the 6L7 heptode, used principally as a mixer in superheterodyne circuits. This tube has *five* grids: control grid, screens, suppressor and special injection grid for oscillator input. Oscillator coupling to control grid and screen grid circuits of ordinary pentodes is effective as far as mixing is concerned, but has the disadvantage of considerable interaction between oscillator and mixer.

The 6L7 has a special *injection grid* so placed that it has reasonable effect on the electron stream without the disadvantage of interaction between the screen and control grid. The principal disadvantage is that it requires fairly high oscillator input in order to realize its high conversion conductance. It may also be used as an r.f. pentode amplifier.

The 6J8G and 6K8 are two tubes specifically designed for converter service. They consist of a heptode mixer unit and a triode unit in the same envelope, internally connected to provide the proper injection for conversion work. While both tubes function as a triode oscillator feeding a heptode mixer, the method of injection is different in the two tubes. In the 6J8G, the control grid of the oscillator is connected internally to a special shielded injector grid in the heptode section. In the 6K8, the number one grid of the heptode is connected internally to the control grid of the oscillator triode.

Single-Ended Tubes. From the introduction of the screen-grid tube to the present time it has been standard practice to bring the control grid (or the no. 1 grid as it is called) of all pentodes and tetrodes designed for radio frequency amplifier use in receivers through the *top* of the envelope. This practice was started because it was much easier to shield the input from the output circuit when one was at the top and the other at the bottom of the envelope. This was true both of the elements and of their associated circuits.

With the introduction of the octal-based metal tube it became feasible to design and manufacture high-gain r.f. amplifier and mixer tubes with all the terminals brought out the base. The metal envelope gives excellent shielding of the elements from external fields, and through the use of a small additional shield inside the locating pin of the octal socket, the diametrically opposite grid and plate pins of the tubes are well shielded from each other. The 6SJ7 and

6SK7 are conventional r.f. amplifier pentodes exemplifying this type of design, the 1852 (6AC7) and 1853 (6AB7) are television amplifier pentodes, the 6SA7 is a new, greatly improved pentagrid converter tube, the 6SQ7 is a diode-high- μ triode and the 6SC7 is a dual triode.

Dual Tubes. Some of the commonly known vacuum tubes are in reality two tubes in one, i.e., in a single glass or metal envelope. Twin triodes, such as the types 53, 6A6, 6SC7, and 6N7 are examples. A disadvantage of these twin-triode tubes for certain applications is the fact that the cathodes of both tubes are brought out to the same base pin.

Of a different nature are the 6H6 twin diode and the 6F8G and 6C8G twin triodes. The cathodes of each of these tubes are brought to a separate base pin on the socket, thus making them true twin triodes. Other types combine the functions of a double diode and either low or high μ triode in the same envelope, as well as a similar combination with a pentode instead of a triode. Still other types combine a pentode and a triode, a pentode and a power supply rectifier, and electron-ray indicating tubes (magic eyes) with their self-contained triode d.c. voltage amplifier.

Manufacturer's Tube Manuals. The larger tube manufacturers offer at a nominal cost tube manuals which are very complete and give much valuable data which, because of space limitations cannot be included in this handbook. Those especially interested in vacuum tubes are urged to purchase one of these books as a supplementary reference.

APPLICATION OF THE VACUUM TUBE

The preceding section of this chapter has been devoted to the theory of vacuum tubes and to the various forms in which they commonly appear. The succeeding section will be devoted to the application of the characteristics and abilities of the vacuum tube to the problems of amplification, oscillation, rectification, detection, frequency conversion, and electrical measurements.

The Vacuum Tube as an Amplifier

The ability of a grid of a vacuum tube to control large amounts of plate power with a small amount of input energy allows the vacuum tube to be used as an amplifier. It is the ability of the vacuum tube to amplify an extremely small amount of energy up to

almost any amount without change in anything except amplitude which makes the vacuum tube such an extremely useful adjunct to modern industry and communication.

The most important considerations of a vacuum tube, aside from its power handling ability (which will be treated later on), are amplification factor, plate resistance, and mutual conductance.

Amplification Factor or μ . The amplification factor or μ (μ) of a vacuum tube is the ratio of a change in plate voltage to a change in grid voltage, either of which will cause the same change in plate current. Expressed as a differential equation:

$$\mu = \frac{dE_p}{dE_g}$$

The μ can be determined experimentally by making a slight change in the plate voltage, thus slightly changing the plate current. The plate current is then returned to its original value by a change in grid voltage. The ratio of the increment in plate voltage to the increment in grid voltage is the μ of the tube. The foregoing assumes that the experiment is conducted on the basis of rated voltages as shown in the manufacturer's tube tables.

The plate resistance can also be determined by the previous experiment. By noting the change in plate current as it occurs when the plate voltage is changed, and by dividing the latter by the former, the plate resistance can then be determined. Expressed as an equation:

$$R_p = \frac{dE_p}{dI_p}$$

The mutual conductance, also referred to as *transconductance*, is the ratio of the amplification factor (μ) to the plate resistance:

$$S_m = \frac{\mu}{R_p} = \frac{dE_p}{dE_g} \frac{dI_p}{dE_p} = \frac{dI_p}{dE_g}$$

The amplification factor is the ability of the tube to amplify or increase the voltages applied to the grid. The amount of voltage amplification that can be obtained from a tube is expressed as follows:

$$\frac{\mu R_L}{R_p + R_L}$$

where R_L is equal to the plate circuit load resistance.

As a practical example, suppose we take the case of a 6F5 tube with a plate resistance of 66,000 ohms and an amplification factor of 100 operating into a load resistance of 50,000 ohms. The voltage amplification of the stage as calculated from the above equation would be:

$$\frac{100 \times 50,000}{50,000 + 66,000} = 43$$

From the foregoing it is seen that an input of 1 volt to the grid of the tube will give an output of 43 volts (a.c.).

Audio-Frequency Amplifiers

Amplifiers designed to operate at a low level at radio, intermediate, and audio frequencies are almost invariably of the class A type. Higher level audio amplifiers can be of the class A, class AB, or class B type; these classifications and their considerations will be considered first. The class B and class C amplifiers as used for medium and high-level radio-frequency work will be considered under *Radio-Frequency Amplifiers*.

The Class A Amplifier. A class A amplifier is, by definition, an amplifier in which the grid bias and alternating grid voltages are such that plate current in a specific tube flows at all times. The output waveform from a class A amplifier is a faithful reproduction of the exciting a.c. voltage upon the grid. For the above conditions to be the case it is necessary that the grid bias, or the operating point, of the amplifier be chosen with care to allow maximum output with minimum distortion.

Figure 5 shows the operating characteristic of a typical vacuum tube. It will be noticed that the curve of plate current with varying grid voltage is quite linear within certain limits—outside these limits it is no longer a straight line. For an amplifier to be able to put out a voltage waveform which is a faithful reproduction of the input waveform, it is necessary that the range over which the grid voltage will be varied shall give a linear variation in plate current. Also, a class A amplifier must not draw grid current; so the operating point must be midway between the point of zero grid bias and the point on the operating characteristic where the curvature becomes noticeable. Such a point has been chosen graphically in figure 5.

When the grid bias is varied around this operating point the fluctuation in grid po-

tential results in a corresponding fluctuation in plate current. When this current flows through a suitable load device, it produces a varying voltage drop which is a replica of the original input voltage, although considerably greater in amplitude.

Should the signal voltage on the grid be permitted to go too far negative, the negative half cycle in the plate output will not be the same as the positive half cycle. In other words, the output wave shape will not be a duplicate of the input, and *distortion* in the output will therefore result. The fundamental property of class A amplification is that the bias voltage and input signal level must not advance beyond the point of zero grid potential; otherwise, the grid itself will become positive. Electrons will then flow into the grid and through its external circuit in much the same manner as if the grid were actually the plate. The result of such a flow of grid current is a lowering of the input impedance of the tube so that power is required to drive it.

Since class A amplifiers are never designed to draw grid current they do not realize the optimum capabilities of any individual tube.

Inspection of the operating characteristic of figure 5 reveals that there is a long stretch of linear characteristic far into the positive grid region. As only the small portion of the operating characteristic below the zero grid bias line can be used, the plate circuit efficiency of a class A amplifier is low. However, they are used because they have very little or negligible distortion and, since only

Figure 5.

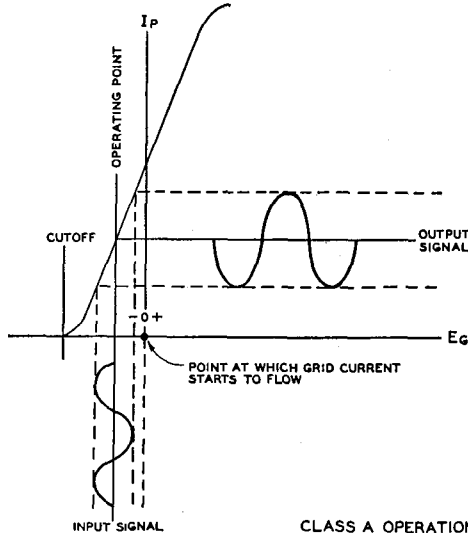

an infinitesimal amount of power is required on the grid, a large amount of power amplification may be obtained. Low-level audio and radio frequency amplifying stages in receivers and audio amplifiers are invariably operated class A. The correct values of bias for the operation of tubes as class A amplifiers are given in the *Tube Tables*.

The Class AB Amplifier. A class AB amplifier is one in which *the grid bias and alternating grid voltages are such that plate current in a specific tube flows for appreciably more than half but less than the entire electrical cycle when delivering maximum output.*

In a class AB amplifier, the fixed grid bias is made higher than would be the case for a push-pull class A amplifier. The resting plate current is thereby reduced and higher values of plate voltage can be used without exceeding the rated plate dissipation of the tube. The result is an increase in power output.

Class AB amplifiers can be subdivided into class AB₁ and class AB₂. There is no flow of grid current in a class AB₁ amplifier; that is, the peak signal voltage applied to each grid does not exceed the negative grid bias voltage. In a class AB₂ amplifier the grid signal is greater than the bias voltage on the peaks, and grid current flows.

The class AB amplifier should be operated in push-pull if distortion is to be held to a minimum. Class AB₂ will furnish more power output for a given pair of tubes than will class AB₁. The grids of a class AB₂ amplifier draw current, which calls for a power driver stage.

The Class B Amplifier. A class B amplifier is one in which *the grid bias is approximately equal to the cutoff value so that the plate current is very low (almost zero) when no exciting grid voltage is applied and so that plate current in a specific tube flows for approximately one half of each cycle when an alternating grid voltage is applied.*

A class B audio amplifier always operates with two tubes in push-pull. The bias voltage is increased to the point where but very little plate current flows. This point is called the *cutoff point*. When the grids are fed with voltage 180 degrees out of phase, that is, one grid swinging in a positive direction and the other in a negative direction, the two tubes will alternately supply current to the load.

When the grid of tube no. 1 swings in a positive direction, plate current flows in this tube. During this process, grid no. 2 swings negatively beyond the point of cutoff; hence, no current flows in tube no. 2. On the other

half-cycle, tube no. 1 is idle, and tube no. 2 furnishes current. Each tube operates on one-half cycle of the input voltage so that the complete input wave is reproduced in the plate circuit. Since the plate current rests at a very low value when no signal is applied, the plate efficiency is considerably higher than in a class A amplifier.

There is a much higher, steady value of plate current flow in a class A amplifier, regardless of whether or not a signal is present. The average plate dissipation or plate loss is much greater than in a class B amplifier of the same power output capability.

For the reason that the plate current rises from a very low to a very high peak value on input swings in a class B audio amplifier, the demands upon the power supply are quite severe; a power supply for class B amplifier service must have good regulation. A high-capacity output condenser must be used in the filter circuit to give sufficient storage to supply power for the stronger audio peaks, and a choke-input filter system is required for good regulation.

Load Impedance for Amplifiers. The plate current in an amplifier increases and decreases in proportion to the value of applied input signal. If useful power is to be realized from such an amplifier, the plate circuit must be terminated in a suitable resistance or impedance across which the power can be developed. When increasing and decreasing plate current flows through a resistor or impedance, the voltage drop across this load will constantly change because the plate current is constantly changing. The actual value of voltage on the plate will vary in accordance with the IZ drop across the load, even though a steady value of direct current may be applied to the load impedance; hence, for an alternating voltage on the grid of the tube, there will be a constant change in the voltage at the anode.

The static characteristic curves give an indication of the performance of the tube for only one value of plate voltage. If the plate voltage is changed, the characteristic curve will shift. This sequence of change can be plotted in a form that permits a determination of tube performance; it is customary to plot the plate current for a series of permissible values of plate voltage at some fixed value of grid voltage.

The process is repeated for a sufficient number of grid voltage values in order that adequate data will be available. A group or family of plate voltage-plate current curves, each for a different grid potential, makes possible the calculation of the correct

load impedance for the tube. Dynamic characteristics include curves for variations in amplification factor, plate resistance, transconductance and detector characteristics.

The correct value of load impedance for a rated power output is always specified by the tube manufacturer. The plate coupling device generally reflects this impedance to the tube. This subject is treated under *Impedance Matching*, Chapter Two.

Tubes in Parallel and Push-Pull. Two or more tubes can be connected in parallel in order to secure greater power output; two tubes in parallel will give approximately twice the output of a single tube. Since the plate resistances of the two tubes are in parallel, the required load impedance will be half that for a single tube.

When power is to be increased by the use of two tubes, it is generally advisable to connect them in push-pull; in this connection the power output is doubled and the harmonic content, or distortion, is reduced. The input voltage applied to the grids of two tubes is 180 degrees out of phase, the voltage usually being secured from a center-tapped secondary winding with the center tap connected to the source of bias and the outer ends of the winding connected to each grid. The plates are similarly fed into a center-tapped winding and plate voltage is introduced at the center tap. The signal voltage supplied to one grid must always swing in a positive direction when the other grid swings negatively. The result is an increase in plate current in one tube with a decrease in plate cur-

Figure 6.

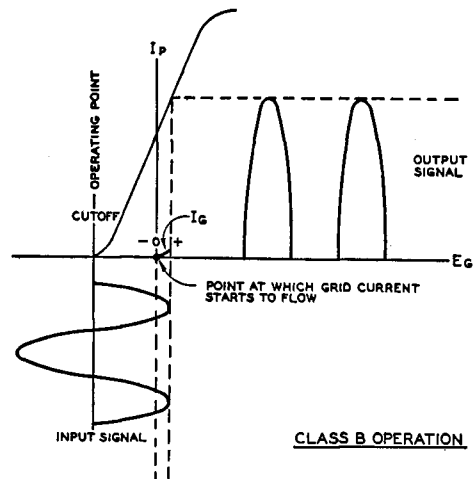

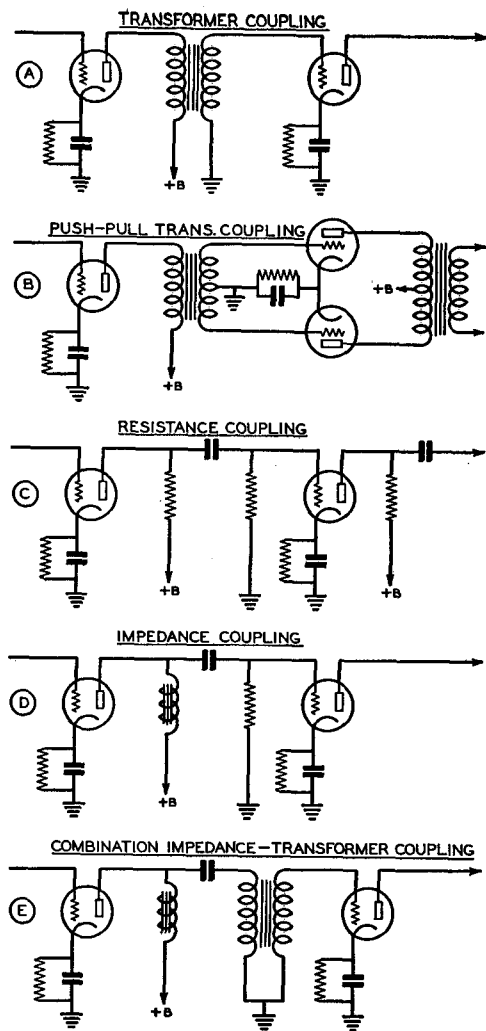

Figure 7.
FIVE COMMON METHODS OF AUDIO FREQUENCY INTERSTAGE COUPLING.

rent in the other at any given instant; one tube *pushes* as the other *pulls*; hence the term: *push-pull*.

Harmonic Distortion in Audio Amplifiers.

Distortion exists when the output wave shape of an amplifier departs from the shape of the input voltage wave. Distortion is present mainly in the form of *harmonics*, which are voltages existing simultaneously with the fundamental at frequencies 2, 3, 4, 5, etc. times this fundamental frequency.

The lower order of harmonics, namely, those whose frequencies are twice and three times that of the fundamental frequency, are

generally the strongest. The presence of strong harmonics in an audio-frequency amplifier gives rise to speech or music distortion plainly apparent to the human ear. The average ear can tolerate a certain amount of distortion, and audio amplifiers are, therefore, rated in percentage of *harmonic content*. The value of 5% is generally accepted as being the maximum permissible total harmonic distortion from an average audio amplifier.

Voltage and Power Amplification. Practically all amplifiers can be divided into two classifications, *voltage amplifiers* and *power amplifiers*. In a voltage amplifier, it is desirable to increase the voltage to a maximum possible value, consistent with allowable distortion. The tube is not required to furnish *power* because the succeeding tube is always biased to the point where no grid current flows. The selection of a tube for voltage amplifier service depends upon the voltage amplification it must provide, upon the load that is to be used and upon the available value of plate voltage. The varying signal current in the plate circuit of a voltage amplifier is employed in the plate load solely in the production of *voltage* to be applied to the grid of the following stage. The plate voltage is always relatively high, the plate current small.

A *power amplifier*, in contrast, must be capable of supplying a heavy current into a load impedance that usually lies between 2000 and 10,000 ohms. Power amplifiers normally furnish excitation to power-consuming devices such as loud-speakers. They also serve as drivers for other larger amplifier stages whose grids require power from the preceding stage. Power amplifiers are common in transmitters.

The difference between the plate power input and output is dissipated in the tube in the form of heat, and is known as the *plate dissipation*. Tubes for power amplifier service have larger plates and heavier filaments than those for a voltage amplifier. High-power audio circuits for commercial broadcast transmitters call for tubes of such proportions that it becomes necessary to cool their plates by means of water or forced-air cooling systems.

Interstage Coupling. Common methods of coupling one stage to another in an audio amplifier are shown in figure 7.

Transformer coupling for a single-ended stage is shown in A; coupling to a *push-pull* stage in B; *resistance coupling* in C; *impedance coupling* in D. A combination *impedance-transformer* coupling system is

shown in E; this arrangement is generally chosen for high permeability audio transformers of small size and where it is necessary to prevent the plate current from flowing through the transformer primary. The plate circuit in the latter is *shunt-fed*. A resistor of appropriate value is often substituted for the impedance in the circuit shown in E.

RADIO-FREQUENCY AMPLIFIERS

Radio-frequency amplifiers as used in transmitters invariably fall into the "power" classification. Also, since they operate into sharply tuned tank circuits which tend to take out irregularities in the plate current waveform and give a comparatively pure sine-wave output, more efficient conditions of operation may be used than for an audio amplifier in which the output waveform must be the same as the input over a wide band of frequencies. The class B and class C r.f. amplifiers fall into this grouping.

The Class B R.F. Amplifier. The definition of a class B r.f. amplifier is the same as that of a class B amplifier for audio use. However, the r.f. amplifier operates into a tuned circuit and covers only a very small range of frequency while the audio type works into an untuned load and may cover a range of 500 or 1000 to 1 in frequency.

Class B radio-frequency amplifiers are used primarily as *linear amplifiers* whose function is to increase the output from a modulated class C stage. The bias is adjusted to the cutoff value. In a single-ended stage, the r.f. plate current flows on alternate half cycles. The power output in class B r.f. amplifiers is proportional to the square of the grid excitation voltage. The grid voltage excitation is doubled in a linear amplifier at 100% modulation, the grid excitation voltage being supplied by the modulated stage; hence, the power output on modulation peaks in a linear stage is increased four times in value. In spite of the fact that power is supplied to the tank circuit only on alternate half cycles, the flywheel effect of the tuned tank circuit supplies the missing half cycle of radio frequency, and the complete waveform is reproduced in the output to the antenna.

The Class C R.F. Amplifier. A class C amplifier is defined as an amplifier in which the grid bias is appreciably greater than the cutoff value so that the plate current in each tube is zero when no alternating grid voltage is applied, and so that plate current in a specific tube flows for appreciably less than one half of each cycle when an alternating grid voltage is applied.

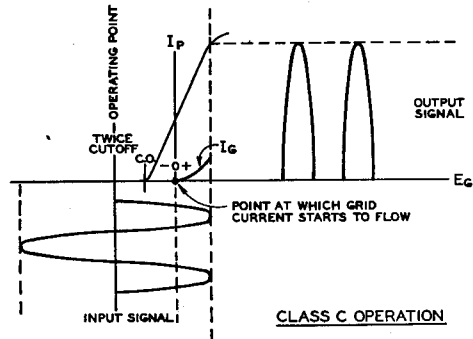

Figure 8.

Angle of Plate Current Flow. The class C amplifier differs from others in that the bias voltage is increased to a point well beyond cutoff. When a tube is biased to cutoff, as in a class B amplifier, it draws plate current for a half cycle or 180° . As this point of operation is carried beyond cutoff, that is, when the grid bias becomes more negative, the angle of plate current flow decreases. Under normal conditions, the optimum value for class C amplifier operation is approximately 120° . The plate current is at zero value during the first 30° because the grid voltage is still approaching cutoff. From 30° to 90° , the grid voltage has advanced beyond cutoff and swings to a maximum in a region which allows plate current to flow. From 90° to 150° , the grid voltage returns to cutoff, and the plate current decreases to zero. From 150° to 180° , no plate current flows since the grid voltage is then beyond cutoff.

The plate current in a class C amplifier flows in pulses of high amplitude, but of short duration. Efficiencies up to 75% are realized under these conditions. It is possible to convert nearly all of the plate input power into r.f. output power (approximately 90% efficiency) by increasing the excitation, plate voltage and bias to extreme values.

Linearity of Class C Amplifiers. The r.f. plate current is proportional to the plate voltage; hence, the power output is proportional to the square of the plate voltage. Class C amplifiers are invariably used for plate modulation because of their high efficiency and because they reflect a pure resistance load into the modulator. The plate voltage of the class C stage is doubled on the peaks at 100% modulation; the power output at this point is consequently increased four times.

Figure 8 illustrates graphically the operation of a class C amplifier with twice cutoff bias and with the peak grid swing of such

a value as just to approach the diode bend in the plate characteristic. When the excitation voltage is increased beyond this point the plate current waveform will have a dip at the crest due to the taking of electrons from the plate current stream by the grid on its highly positive peaks.

The Vacuum Tube as an Oscillator

The ability of an amplifier tube to control power enables it to function as an oscillator or a generator of alternating current in a suitable circuit. When part of the amplified output is coupled back into the input circuit, sustained oscillations will be generated provided the input voltage to the grid is of the proper magnitude and phase with respect to the plate.

The voltage that is fed back and applied to the grid must be 180° out of phase with the voltage across the load impedance in the plate circuit. The voltage swings are of a frequency depending upon circuit constants.

If a parallel resonant circuit consisting of an inductance and capacitance is inserted in series with the plate circuit of an amplifier tube and a connection is made so that part of the potential drop is impressed 180° out of phase on the grid of the same tube, amplification of the potential across the L/C circuit will result. The potential would increase to an unrestricted value were it not for the limited plate voltage and the limited range of linearity of the tube characteristic, which causes a reversal of the process after a certain point is reached. The rate of reversal is determined by the time constant or resonant frequency of the tank circuit.

The frequency range of an oscillator can be made very great; thus, by varying the circuit constants, oscillations from a few cycles per second up to many millions can be generated. A number of different types of oscillators are treated in detail under the section devoted to *Transmitter Theory*.

The Vacuum Tube as a Rectifier

It was stated at the first of this chapter that when the potential of the plate of a two-element vacuum tube or diode is made positive with respect to the cathode, electrons emitted by the cathode will be attracted to the plate and a current will flow in the external circuit that returns the electrons to the cathode. If, on the other hand, the plate is made negative with respect to the cathode the electron flow in the external circuit will cease due to the repulsion of the electronic stream

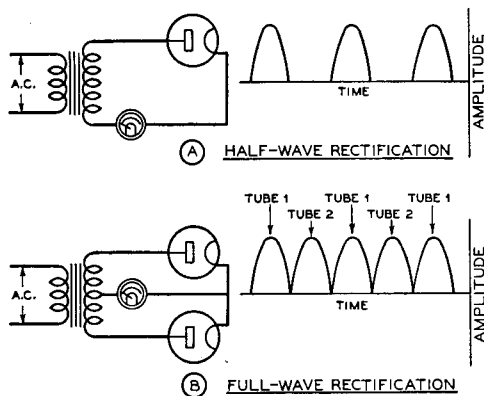

Figure 9.

within the tube back to the cathode. From this is derived a valuable property, namely, the ability of a vacuum tube to pass current in one direction only and hence to function as a *rectifier* or a device to convert alternating current into pulsating d.c.

The Half-Wave Rectifier. Figure 9A shows a half-wave rectifier circuit. For convenience of explanation, a conventional power rectifier has been chosen although the same diagram and explanation would apply to diode rectification as employed in the detector circuits of many receivers.

When a sine-wave voltage is induced in the secondary of the transformer, the rectifier plate is made alternately positive and negative as the polarity of the alternating current changes. Electrons are attracted to the plate from the cathode when the plate is positive, and current then flows in the external circuit. On the succeeding half cycle, the plate becomes negative with respect to the cathode, and no current flows. Thus, there will be an interval before the succeeding half cycle occurs when the plate again becomes positive. Under these conditions, plate current once more begins to flow and there is another pulsation in the output circuit.

For the reason that one half of the complete wave is absent in the output, the result is what is known as *half-wave rectification*. The output power is the average value of these pulsations; it will, therefore, be of a low value because of the interval between pulsations.

Full-Wave Rectification. In a *full-wave circuit* (figure 9B), the plate of one tube is positive when the other plate is negative; although the current changes its polarity, one of the plates is always positive. One tube, therefore, operates effectively on each half

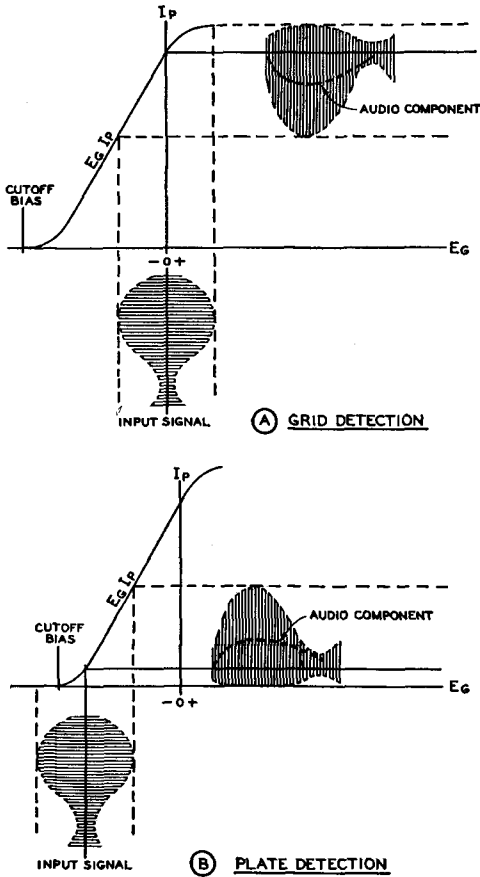

Figure 10.

ILLUSTRATING DETECTOR OPERATION IN UPPER AND LOWER-BEND PORTION OF THE CHARACTERISTIC CURVE.

cycle, but the output current is in the same direction. In this type of circuit the rectification is complete and there is no gap between plate current pulsations. This output is known as *rectified a.c.* or *pulsating d.c.*

Mercury Vapor Rectifiers. If a two-element electron tube is evacuated and then filled with a gas such as mercury vapor, its characteristics and performance will differ radically from those of an ordinary high-vacuum diode tube.

The principle upon which the operation of a gas-filled rectifier depends is known as the phenomenon of gaseous ionization, which was discussed under *Fundamental Theory*. Investigation has shown that the electrons emitted by a hot cathode in a mercury-vapor tube are accelerated toward the anode (plate) with great velocity. These electrons move

in the electrical field between the hot cathode and the anode. In this space they collide with the mercury-vapor molecules which are present.

If the moving electrons attain a velocity so great as to enable them to break through a potential difference of more than 10.4 volts (for mercury), they will literally knock the electrons out of the atoms with which they collide.

As more and more atoms are broken up by collision with electrons, the mercury vapor within the tube becomes *ionized* and transmits a considerable amount of current. The ions are repelled from the anode when it is positive; they are then attracted to the cathode, thus tending to neutralize the negative space charge as long as saturation current is not drawn. This effect neutralizes the negative space charge to such a degree that the voltage drop across the tube is reduced to a very low and constant value. Furthermore, a considerable reduction in heating of the diode plate, as well as an improvement in the voltage regulation of the load current, is achieved. The efficiency of rectification is thereby increased because the voltage drop across any rectifier tube represents a waste of power.

Detection or Demodulation

Detection is the process by which the audio component is separated from the modulated radio-frequency signal carrier at the receiver. Detection always involves either rectification or nonlinear amplification of an alternating current.

Two general types of amplifying detectors are used in radio circuits:

The Plate Detector. The plate detector or *bias detector* (sometimes called a *power detector*) amplifies the radio-frequency wave and then rectifies it and passes the resultant audio signal component to the succeeding audio amplifier. The detector operates on the lower bend in the plate current characteristic, because it is biased close to the cutoff point and therefore could be called a single-ended class B amplifier. The plate current is quite low in the absence of a signal and the audio component is evidenced by an increase in the average unmodulated plate current. See figure 10.

The Grid Detector. The grid detector differs from the plate detector in that it rectifies in the grid circuit and then amplifies the resultant audio signal. The only source of grid bias is the grid leak so that the plate current is maximum when no signal is present. This form of detector operates on the upper

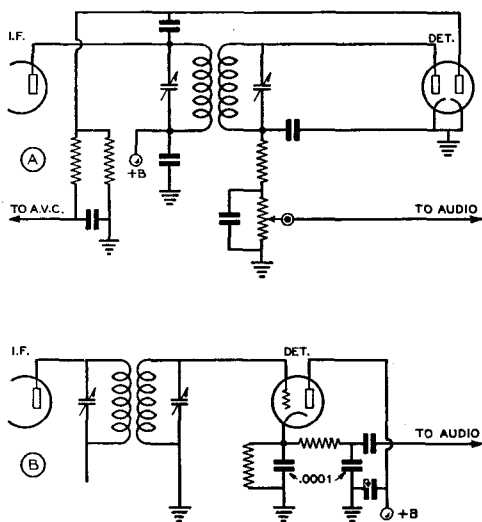

Figure 11.

(A) THE DIODE DETECTOR WITH SEPARATE A.V.C. RECTIFIER. (B) INFINITE IMPEDANCE DETECTOR.

or saturated bend of its characteristic curve and the demodulated signal appears as an audio-frequency decrease in the average plate current. However, at low plate voltage, most of the rectification takes place as the result of the *curvature* in the grid characteristic. By proper choice of grid leak and plate voltage, distortion can be held to a reasonably small value. In extreme cases the distortion can reach a very high value, particularly when the carrier signal is modulated to a high percentage. In such cases the distortion can reach 25%.

The grid detector will absorb some power from the preceding stage because it draws grid current. It is significant to relate that the higher gain through the grid detector does not necessarily indicate that it is more sensitive. Detector sensitivity is a matter of *rectification efficiency* and amplification, not of amplification alone. Grid leak detectors are often used in regenerative detector circuits because smoother control of *regeneration* is possible than in other forms of plate and bias detectors.

Non-Amplifying Detectors. In addition to the two previous types of amplifying detectors, both of which have a certain inherent amount of harmonic distortion, there are two main types of non-amplifying detectors which have, of late, been more widely used because of their lowered harmonic distortion and other advantages.

The Diode Detector.—In this type of detector the input r.f. signal (almost invariably at the intermediate frequency of the receiver) is simply rectified by the diode and the modulation component appears as an alternating voltage, in addition to the d.c. component, across the diode load resistor. This type of detection, although it gives no gain and has a loading effect on the circuit that feeds it, is frequently used in high-quality receivers because of the relatively distortionless detection or demodulation that is obtained. Figure 11A shows a combined detector-a.v.c. rectifier circuit commonly used in high-quality receivers. It will be noticed that a separate diode and rectifier circuit is used to obtain the a.v.c. voltage. This is done to eliminate the *a.c. shunt loading* of the a.v.c. bus upon the detector circuit. If the a.v.c. voltage is taken from the detector diode load resistor, the effect of the a.c. shunt loading of the a.v.c. circuit can be serious enough to cause as high as 25 per cent harmonic distortion of a 100 per cent modulated input signal. However, inexpensive midget receivers in which the high-frequency response is limited frequently take the a.v.c. voltage from the detector load resistor and rely upon the limited high-frequency response to make the distortion unnoticeable.

Certain circuits are available for compensating for the a.c. shunt loading effect of the a.v.c. circuit upon the detector load resistor, but the most satisfactory arrangement is that shown in 11A in which a separate rectifier taking its r.f. voltage from the plate of the last i.f. amplifier is used to supply the a.v.c. voltage. It is also best that the lead marked "to audio" in figure 11A connect directly to the first audio grid, and thus that diode biasing be used upon this grid. If an additional condenser and potentiometer is used between the diode load resistor and the first audio stage the shunt loading effect of the additional volume control resistor can be as serious as the a.c. loading of the a.v.c. circuit.

The Infinite Impedance Detector. Figure 11B illustrates this comparatively recently popularized type of detector circuit which has advantages over previous types where distortion-free detection is required. The circuit is essentially the same as that for plate or power-detection except that the output voltage is taken from the cathode circuit instead of from the plate. This gives the advantage that practically 100 per cent degenerative feedback is incorporated into the circuit with a consequent great reduction in harmonic distortion as compared to the simple plate de-

detector. The circuit gives no loading to the circuit from which it obtains its voltage—hence the name, infinite-impedance detection. Also, due to the 100 per cent degenerative feedback, the circuit has a gain of one. Essentially the same output voltage will be obtained from this detector as will be obtained from a diode detector.

When automatic volume control is to be used in a receiver which employs an infinite impedance detector, the a.v.c. rectifier circuit shown using the right hand diode of figure 11A can be used. It is common practice to use a combination tube such as the 6B8 as a combined last i.f. amplifier and a.v.c. rectifier, with a separate tube such as a 6J5 as the infinite impedance detector.

Frequency Converters or Mixers. Another common usage of the vacuum tube is as a frequency changer or mixer tube. This is the operation performed by the first detector or mixer in a super-heterodyne and consists of changing (most frequently) a particular high-frequency signal (bearing the desired modulation) to a fixed intermediate frequency. In this service the high-frequency signal and another signal from a local oscillator whose frequency is either lower or higher than the h.f. signal by an amount equal to the intermediate frequency (the frequency to which it is desired to convert) are fed to appropriate grids of the converter tube. The resultant intermodulation of the two signals in the converter tube produces one frequency which is the sum of the two, and another frequency which is equal to the difference between their frequencies. It is this latter frequency which is selected by the output circuit of the mixer tube and which is subsequently fed to the intermediate frequency amplifier.

Conversion Conductance. The relative efficiency of a converter tube in changing one frequency to another is called its conversion conductance or transconductance. Recent improvements in mixer tubes have allowed sizeable improvements to be made in the efficiency

of mixer stages. With the latest types of mixer tubes it is possible to obtain nearly as much gain from a frequency changing stage as from an amplifier stage with its input and output circuits on the same frequency. Discussion of mixer characteristics will be found in the chapter, *Receiver Theory*, and under the section *Special Purpose Mixer Tubes* earlier in this chapter.

The Vacuum Tube as a Measuring Device.

The characteristics of the vacuum tube make it very well suited for use as a measuring device in electrical circuits, especially when no power may be taken from the circuit under measurement. Vacuum tube voltmeters are the most common application of this principle. V.t. voltmeters of the peak-indicating and r.m.s. types will be found in the chapter *Test and Measurement Equipment*.

Particular types of vacuum tube voltmeters utilizing the action of an electron stream upon a fluorescent material to give a visual indication are the electron-ray or "magic-eye" tubes, and the cathode-ray oscilloscope. In the electron-ray tube a small knife whose charge varies with the voltage under measurement (usually the amplified d.c. voltage of an a.v.c. circuit) deflects the electron stream to produce a varying angle of fluorescence on the visible screen at the end of the tube.

In the cathode-ray tube an electron gun consisting of cathode, grid, and accelerating anode or plate shoots a fine beam of electrons between two sets of deflecting plates separated by 90° to a fluorescent viewing screen at the end of the tube. One set of deflecting plates is most commonly set up so that it will deflect the stream of electrons back and forth in the horizontal plane. The other set of deflecting plates is oriented so that it will deflect the same stream up and down in the vertical plane. The practical design, construction and application of the cathode-ray oscilloscope to the problems of the amateur station is covered in the *Test and Measurement Equipment* chapter.

CHAPTER FOUR

Radio Receiver Theory

A radio receiver may be defined as a device for reproducing in the form of useful output the intelligence conveyed by radio waves applied to it. Usually an antenna is a necessary adjunct to the receiver. The antenna will not be discussed in this chapter, however, as the function and design of antennas is thoroughly covered in Chapter 20.

Receiver Tubes. The tube manufacturers have been lavish in their production of tubes for use in radio receivers. Many similar tubes are made in different forms, such as metal tubes, glass tubes with standard bases, glass tubes with octal bases similar to those used on metal tubes, glass tubes with tubular envelopes, glass tubes encased in metal shells and fitted with octal bases and tubes with similar characteristics but differing in their heater or filament voltage and current ratings. Some tubes are designed for dry-battery filament supply, others for automobile service and another group for operation from an a.c. source.

In general, there are certain distinct classes of tubes for particular purposes. Screen-grid tubes were primarily designed for radio-frequency amplifiers, yet they are often employed for regenerative detectors, mixers and high-gain voltage audio amplifiers. General purpose triode tubes are used as oscillators, detectors and audio amplifiers. Power triodes, tetrodes and pentodes are employed for obtaining as much power output as possible in the output audio amplifier stage of a radio receiver. Diodes are designed for use as power supply rectifiers, radio detectors, automatic volume control circuits and noise suppression circuits. In addition to these general types of tubes, there are a great many others designed for some particular service, such as oscillator-mixer operation in a superheterodyne receiver.

Vacuum tubes require a source of power for the filament and other electrodes. Certain components in a radio receiver are for

the purpose of supplying direct-current energy to the electrodes of the tubes, such as the plate and screen circuits. In nearly all circuits, the control grid of the vacuum tube is biased negatively with respect to the cathode, for proper amplifier action. This bias is obtained in several ways, such as from a self-biasing resistor in series with the cathode, fixed bias from the power supply or grid leak bias for some oscillators and detectors.

By-pass and coupling condensers are found in different portions of the circuits throughout a radio receiver. By-pass condensers provide a low impedance for r.f. or audio frequencies around such components as resistors and choke coils. Coupling condensers provide a means of connection between plate and grid circuits in which the d.c. voltage components are of widely different values. The coupling condenser offers an infinite impedance to the d.c. voltages, and a relatively low impedance to the r.f. or a.f. voltages.

Screen-grid tubes have a higher plate impedance than triodes and, therefore, require a much higher value of plate load impedance in order to obtain the greatest possible amount of amplification in the audio or radio circuits. Screen-grid tubes are normally used in all r.f. and i.f. amplifiers because the control grid is electrostatically screened from the plate circuit. Lack of this screening would cause self-oscillation in the amplifier; when triodes are used in radio-frequency amplifiers, the grid-to-plate capacities must be neutralized. The r.f. amplification from a triode amplifier in a radio receiver is so much less than can be obtained from a screen-grid tube amplifier that triodes are no longer used for this purpose.

Detection. All receivers use some sort of detector to make audible the intelligence impressed on the radiated carrier wave at the transmitter. The process of impressing the intelligence on the carrier wave is known as modulation, and as the detector separates this

modulation from the carrier, it is often known as a *demodulator*. One of the simplest practical receivers consists of a tuned circuit for selecting the desired radio signal and a detector for separating the modulation from the carrier. The detector may be either a mineral such as galena or carborundum, or else a vacuum tube. Figure 1 shows such a receiver using a diode vacuum tube as a detector. The *sensitivity* of this receiver, or in other words its ability to make audible weak signals, would be very low, but it is useful to illustrate the basic action of all receivers.

Resonant Circuits such as are formed by coil L_2 and condenser C , are almost always used to couple the antenna to the first tube in a radio receiver. When the current induced in the antenna is caused to pass through a coil, such as L_1 in figure 1, a voltage is induced across the coil. It will be recalled from chapter 1 that this voltage across the coil is equal to the product of the current and the impedance of the coil. The impedance of a non-resonant coil such as L_1 is made up principally of its reactance. This reactance is a function of the coil dimensions and the frequency of the impressed current.

Coils L_1 and L_2 in figure 1 are said to be *inductively coupled*, as radio-frequency energy is transferred from one to the other by virtue of the fact that the alternating inductive field around L_1 links and unlinks with the turns of L_2 , thus inducing a voltage in L_2 .

Disregarding the tube, V , for the moment, the current flowing through L_2 of figure 1 is limited by the reactances of the coil and condenser C . The reactance of the coil increases with frequency while the reactance of the variable condenser decreases with frequency. For any setting of C there is a frequency at which the *capacitive reactance* and the *inductive reactance are equal*. These two reactances are opposite in effect and neutralize each other at this frequency, resulting in a circuit having zero reactance, and a condition known as *resonance*.

At resonance the current flowing back and forth between L_2 and C is limited only by their resistances, and since the resistance of modern condensers is very small, the current is actually limited by the resistance of the coil. The high radio-frequency (r.f.) current flowing through the coil and condenser causes an r.f. voltage to be developed across them equal to the product of the current and the impedance of the circuit. As the impedance of the parallel tuned circuit at resonance is high, the voltage across it is also

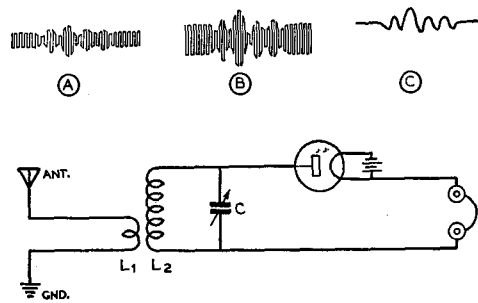

Figure 1.
DIODE DETECTOR RECEIVER.

While it would make a poor receiver, this type of circuit is useful in illustrating how the detector separates the modulation from the carrier wave.

high. Thus, it may be seen that at its resonant frequency the voltage across a tuned circuit may be very much higher than what might be expected from looking at the diagram and assuming that a simple transformer action took place between the primary and secondary.

The voltage step-up in the tuned circuit is illustrated by the drawings representing the modulated carrier wave above the different portions of the receiver circuit in figure 1. "A" represents the radio signal as it is picked up at the antenna, while "B" represents the same wave considerably increased in amplitude after it has passed through the tuned circuit.

Rectification of the radio-frequency carrier takes place in the diode vacuum tube, V , and a pulsating d.c. voltage as illustrated at "C" is passed through the earphones. The pulsations in this voltage correspond to the modulation voltage originally placed on the carrier wave at the transmitter. As the diaphragms in the earphones vibrate back and forth following this pulsating d.c. voltage they audibly reproduce the modulation on the carrier.

Regenerative Receivers

The Triode Detector. The simple receiver shown in figure 1 would be an extremely poor one, being suitable for use only in the immediate vicinity of a transmitting station. The sensitivity of the receiver may be increased considerably by replacing the diode detector by a triode in a regenerative detector circuit as shown in figure 2.

The regenerative receiver has been quite popular in high-frequency work for many years. It combines high sensitivity, simplicity, low cost, good signal-to-noise ratio and

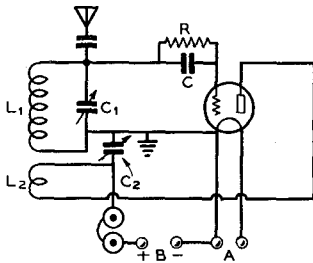

Figure 2.

TRIODE REGENERATIVE DETECTOR.

The regenerative detector makes the simplest practical high-frequency receiver.

reliability. Its principal disadvantage, however, and the one which has caused it to assume a secondary role in the high-frequency receiver picture, is its lack of selectivity when subjected to large signal inputs.

Operation. The regenerative detector, diagrammed in figure 2, operates as follows: In the absence of a signal in the input circuit and with the proper voltages applied to the filament and plate, the plate current assumes a value near the upper bend of the tube's plate characteristic. When a signal voltage is applied across the input circuit the plates on the coil side of the grid condenser, C, become positive (lose some of their electrons) each half-cycle of the signal voltage. When this side of the grid condenser goes positive, electrons from the filament flow to the grid and into the plates on the grid side of C, the resulting excess of electrons trapped on the grid causing it to assume a negative potential and reducing the plate current.

To prevent the grid from becoming more and more negative as electrons accumulate on the condenser, a high-resistance grid leak, R, is connected across the condenser. This resistor allows the negative charge on the grid to become cumulative only during the number of r.f. cycles that constitute one-half an audio cycle, thus allowing the plate current to follow the modulation on the impressed signal. This type of *grid-leak detector* gives high audio output, since rectification takes place in the grid circuit and the amplifying properties of the tube are utilized. Unfortunately, however, this type of detector is prone to give rather high distortion when signals having a large percentage of modulation are impressed on it. The grid-leak detector is not limited to triodes; either tetrodes or pentodes may be used, these generally having greater sensitivity than the triodes.

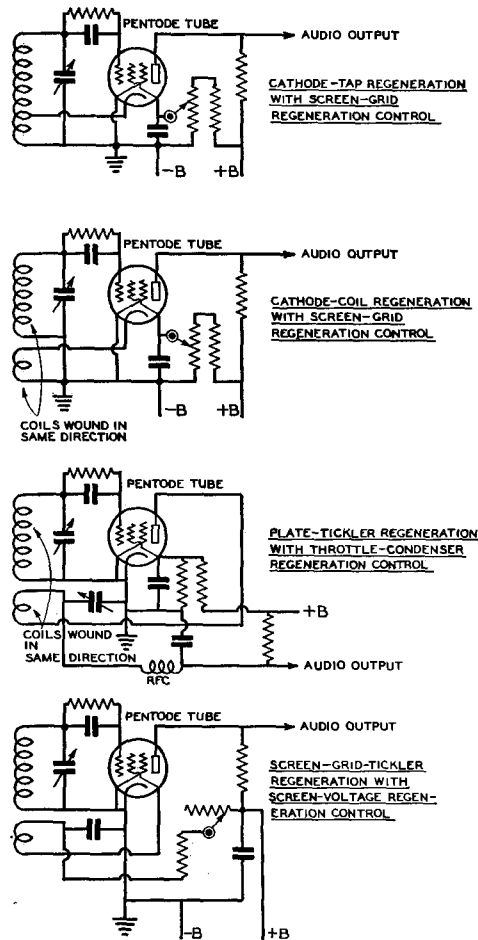

Figure 3.

REGENERATIVE DETECTOR CIRCUITS.

These circuits illustrate some of the more popular regenerative detectors. Values of one to three megohms for grid leaks are common. The grid condenser usually has a capacity of .0001 μ fd., while the screen by-pass is 0.1 μ fd. Pentode detectors operate best when the feedback is adjusted so that they start to oscillate with from 30 to 50 volts on the screen grid.

For the reception of c.w. (constant-wave telegraphy) signals, it is necessary to provide some means of securing a heterodyne, or "beat note" with the incoming signal. In the autodyne detector this is done by coupling some of the radio-frequency energy in the plate circuit back into the grid circuit and allowing the tube to oscillate weakly. The feedback or *tickler*, coil, L₂, is closely coupled to the grid coil and thus provides the feedback necessary to make the stage oscillate.

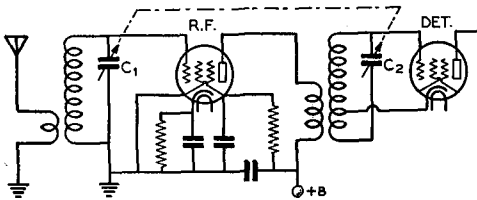

Figure 4.
R.F. AMPLIFIER CIRCUIT.

An r.f. amplifier ahead of the regenerative detector will increase the receiver's selectivity and sensitivity.

Since the detector is most sensitive on the edge of oscillation, a variable condenser, C_2 , may be used as a variable plate by-pass to adjust the detector for its most sensitive condition. This condenser is called a "throttle condenser," or regeneration control.

With the detector *regenerative*, that is, with feedback taking place, but not enough to cause oscillation, it is also extremely sensitive. When the circuit is adjusted to operate in this manner, modulated signals may be received with considerably greater strength than when the detector is in a non-regenerative condition.

Other Regenerative Detectors. The circuit shown in figure 2 is by no means the only one which will give satisfactory results as a regenerative detector. There are several methods by which regeneration may be obtained, and also several alternative methods of controlling the regeneration. In tubes with an indirectly-heated cathode, regeneration may be obtained by tapping the cathode onto the grid coil a few turns up from the ground end or by returning the cathode to ground through a coil coupled to the grid winding. With tetrode or pentode tubes, feedback is sometimes provided by connecting the screen, rather than the plate, to the tickler coil.

Alternative methods of controlling regeneration consist of providing means for varying the voltage on one of the tube elements, usually the plate or screen. Examples of some of the possible variations in regeneration and control methods are shown in figure 3.

Amplifier Stages

The sensitivity and selectivity of the receiver may be increased by adding a tuned radio-frequency amplifier between the detector and the antenna. The radio-frequency (r.f.) amplifier stage increases the strength of the r.f. voltage applied to the detector, and

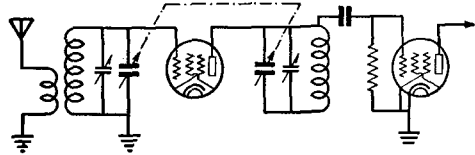

Figure 5.
CAPACITY COUPLING BETWEEN STAGES.
This type of coupling circuit is often used at ultra-high frequencies when it is desired to have a high impedance plate load for the r.f. stage.

thus the receiver with an r.f. stage is capable of giving a useful audio output on signals much weaker than those which represent the minimum useful level of signal strength for the detector alone. The addition of the tuned circuits required in the r.f. amplifier also increases the selectivity of the receiver.

Audio frequency amplifiers may be added after the detector to enable weak signals which have been detected to be amplified sufficiently to actuate the sound producing mechanism in the headphones or speaker.

Radio Frequency Amplifiers. A typical tuned radio-frequency amplifier connected ahead of a regenerative detector is shown in figure 4. A pentode tube is used in the r.f. stage with a tuned grid circuit and inductive coupling from the antenna and to the detector. Capacitive coupling could be used in both instances, but in the case of the coupling between stages a high-impedance radio-frequency choke would have to be connected to the plate of the r.f. stage to allow plate voltage to be applied to the tube. A capacity-coupling system which allows the r.f. choke to be dispensed with is shown in figure 5. This circuit is often used at ultra-high frequencies where a high-impedance resonant circuit in the plate of the r.f. tube is desired in order to obtain greater amplification.

The dotted line running between condensers C_1 and C_2 in figure 4 indicates that their rotor shafts are mechanically connected (or *ganged*) together so that both tuned circuits may be resonated to the desired signal with but a single dial. When the r.f. stage is separate from the receiver and its tuning control is not ganged with that of the receiver proper it is commonly known as a *preselector*. A preselector may be added to any receiver but it is most often used with the super-heterodyne type.

The amplification obtained in an r.f. stage depends upon the type of circuit which is used; if the plate load impedance can be made very high, the gain may be as much as 200 or 300 times that of the signal impressed across the grid circuit. Normal values of gain in the

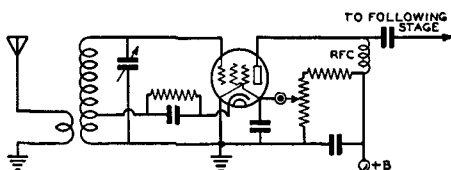

Figure 6.

REGENERATIVE R.F. AMPLIFIER CIRCUIT.

The use of regeneration in an r.f. stage allows greater amplification to be obtained at the expense of an increase in tube noise.

broadcast band are in the vicinity of 50 times. A gain of 30 per r.f. stage is considered excellent for shortwave receivers which have a range of from 30 to 100 meters. Radio-frequency amplifiers for the very short wavelengths, such as from 50 to 20 meters, seldom provide a gain of more than 10 times, because of the difficulty in obtaining high load impedances, and the shunt effect of the rather high input capacities of most screen-grid tubes.

Regenerative R.F. Stages. In low cost receivers and in those where maximum performance with a minimum number of stages is desired, controlled regeneration in an r.f. stage is often used. The regenerative r.f. amplifier increases amplification and selectivity in a manner similar to that of the regenerative detector. The regenerative r.f. amplifier is never allowed to oscillate, however; the greatest amplification is obtained with the circuit operating just below the point of oscillation. Figure 6 shows a regenerative r.f. stage of the type generally used on the higher frequencies.

One minor disadvantage of the regenerative r.f. stage is the need for an additional control for regeneration. A more important disadvantage is that, due to the high degree of selectivity obtainable with the regenerative stage, it is usually impossible to secure accurate enough tracking between its tuning circuit and the other tuning circuits in the receiver to make single-dial control feasible. Where single-dial control is desired, a small "trimmer" condenser is usually provided across the main r.f.-stage tuning condenser. By making this condenser operable from the front panel, it is possible to compensate manually for slight inaccuracies in the tracking. A further discussion of regenerative r.f. stages will be found under the section on superheterodyne receivers, in which connection they are most often used.

Audio Amplifiers. Audio amplifiers are employed in nearly all radio receivers. The audio amplifier stage or stages are usually of

the class A type, although small class B stages are used in some receivers. The operation of both of these types of amplifier was described in Chapter 3. The purpose of the audio amplifier is to bring the relatively weak signal from the detector up to a strength sufficient to operate a pair of headphones or a loud speaker. Either triodes, pentodes, or beam tetrodes may be used, the pentodes and beam tetrodes usually giving greater output. In some receivers it is possible to operate the headphones directly from the detector, without audio amplification. In such receivers a single audio stage with a beam tetrode or pentode tube is ordinarily used to drive the loud speaker. Several representative audio amplifier arrangements will be found in the chapter on Receiver Construction.

Superregenerative Receivers

At ultra-high frequencies, when it is desired to keep weight and cost at a minimum, a special form of the regenerative receiver known as the *superregenerator* is often used. The superregenerator is essentially a regenerative receiver with a means provided to throw the detector rapidly in and out of oscillation. The frequency at which the detector is made to go in and out of oscillation varies in different receivers but is usually between 20,000 and 100,000 times a second. As a consequence of having the detector go in and out of oscillation at such a rapid rate, a loud hiss is present in the audio output when no signal is being received. This hiss diminishes in proportion to the strength of the signal being received, loud signals eliminating the hiss entirely.

Detector Operation. There are two systems in common use for causing the detector to break in and out of oscillation rapidly. In one a separate *interruption-frequency* oscillator is arranged so as to vary the voltage rapidly on one of the detector tube elements (usually the plate, sometimes the screen) at the high rate necessary. The interruption-frequency oscillator commonly uses a conventional tickler-feedback circuit with coils appropriate for the frequency at which it operates.

The second, and simplest, type of superregenerative detector circuit is arranged so as to produce its own interruption frequency oscillation, without the aid of a separate tube. The detector tube damps (or "quenches") itself out of signal-frequency oscillation at a high rate by virtue of the use of a high value of grid leak and proper size plate-blocking and grid condensers. In this type

of "self-quenched" detector the grid leak is usually returned to the positive side of the power supply (through the coil) rather than to the cathode. A representative self-quenched superregenerative detector circuit is shown in figure 7.

Both types of superregenerative detectors act as small transmitters and radiate broad, rough signals unless they are well shielded and preceded by an r.f. stage. For this reason they are not too highly recommended for use on frequencies below 60 Mc. However, there are occasionally cases where their use is justified on the 56-to-60 Mc. band. The superregenerative receiver tunes very broadly, receiving a band at least 100 kc. wide. For this reason it is widely popular for the reception of unstable, modulated oscillators at ultra-high frequencies.

Frequency modulation reception is possible with superregenerative receivers, although with the amount of "swing" ordinarily used in frequency-modulated transmitters the audio output of the receiver is comparable to that obtained when the signal is amplitude modulated at a rather low percentage. If a relatively wide swing is used in the transmitter, however, the audio output of the receiver will compare favorably with that obtained from a fully amplitude modulated carrier of equivalent strength.

Practical superregenerative receiver circuits along with a further discussion of their operation will be found in Chapter 18.

Superheterodyne Receivers

Because of its superiority and nearly universal use in all fields of radio reception except at the extremely high "micro wave" frequencies, the theory of operation of the superheterodyne should be familiar to every radio experimenter, whether or not he contemplates building a receiver of this type. The following discussion concerns superheterodynes for amplitude-modulation reception. It is, however, applicable in part to receivers for frequency modulation. The points of difference between the two types of receivers together with circuits required for F.M. reception will be found in Chapter 9.

Principle of Operation. In the superheterodyne, a radio-frequency circuit is tuned to the frequency of the incoming signal and the signal across this circuit applied to a vacuum-tube mixer stage. In the mixer stage the signal is mixed with a steady signal generated in the receiver, with the result that a signal bearing all the modulation applied to the original but of a frequency equal to the

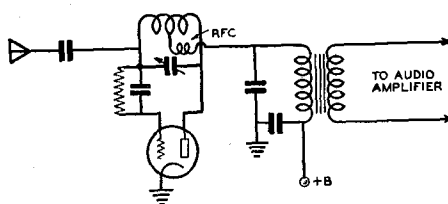

Figure 7.

SUPERREGENERATIVE DETECTOR.

This extremely sensitive self-quenched detector arrangement is often used at ultra-high frequencies. The plate blocking condenser must have low reactance at the quench frequency; a value of .006 μ fd. is common.

difference between the local oscillator and incoming signal frequencies appears in the mixer output circuit. The output from the mixer stage is fed into a fixed-tune intermediate-frequency amplifier, where it is amplified and detected in the usual manner and passed on to the audio amplifier. Figure 8 shows a block diagram of the fundamental superheterodyne arrangement.

Superheterodyne Advantages. The advantages of superheterodyne reception are directly attributable to the use of the fixed-tune intermediate-frequency (i.f.) amplifier. Since all signals are converted to the intermediate frequency, this section of the receiver may be designed for optimum selectivity and amplification without going into the extremely complicated tunable band pass arrangements or the number of stages which would be necessary if the signal-frequency tuning circuits were designed to have a comparable degree of selectivity and gain. High amplification is easily obtained in the intermediate-frequency amplifier, since it operates at a relatively low frequency, where conventional pentode-type tubes give a great deal of voltage gain. A typical i.f. amplifier stage is shown in figure 9.

From the diagram it may be seen that both the grid and plate circuits are tuned. Tuning

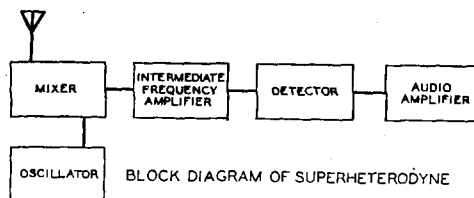

Figure 8.

THE ESSENTIAL PARTS OF A SUPERHETERODYNE RECEIVER.

There are several possible variations of this arrangement. R.f. amplifier stages often are used ahead of the mixer. Occasionally the i.f. amplifier stages are omitted in simple superheterodynes.

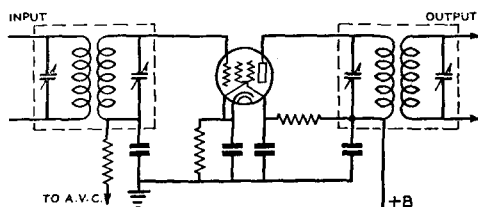

Figure 9.
INTERMEDIATE FREQUENCY AMPLIFIER STAGE.

6K7 and 6SK7 variable- μ pentodes are usually used as i.f. amplifier tubes. These types require cathode and screen resistors of approximately 300 and 100,000 ohms, respectively. The higher transconductance types such as the 1851-52-53 will require lower values of cathode and screen resistors for best operation. By-pass condensers are usually .05 or 0.1 μ fd.

both circuits in this way is advantageous in two ways: it increases the selectivity, and it allows the tubes to work into a high-impedance resonant plate load, a very desirable condition where high gain is desired. The tuned circuits used for coupling between i.f. stages are known as *i.f. transformers*. These will be more fully discussed later in this chapter.

Choice of Intermediate Frequency. The choice of a frequency for the i.f. amplifier involves several considerations. One of these considerations is in the matter of selectivity; as a general rule, the lower the intermediate frequency the better the selectivity. On the other hand, a rather high intermediate frequency is desirable from the standpoint of *image* elimination and also for the reception of signals from television and F.M. transmitters and modulated self-controlled oscillator, all of which occupy a rather wide band of frequencies, making a broad selectivity characteristic desirable. Images are a peculiarity common to all superheterodyne receivers, and for this reason they are given a detailed discussion later in this chapter.

While intermediate frequencies as low as 30 kc. were common at one time, and frequencies as high as 20,000 kc. are used in some specialized forms of receivers, most present-day communications superheterodynes nearly always use intermediate frequencies around either 455 kc. or 1600 kc. Two other frequencies which are sometimes encountered in broadcast-band receivers are 175 kc. and 262 kc.

Generally speaking, it may be said that for maximum selectivity consistent with a reasonable amount of image rejection for signal frequencies up to 30 Mc., intermediate frequencies in the 450-470 kc. range are used, while for a good compromise between image rejection

and selectivity the i.f. amplifier will often operate at 1600 kc. For the reception of both amplitude and frequency modulated signals above 30 Mc., intermediate frequencies near 2100, 3000 and 5000 kc. are most often used. The intermediate amplifiers in television receivers will usually be found to operate in the region between 8000 and 15,000 kc.

Arithmetical Selectivity. Aside from allowing the use of fixed-tune band pass amplifier stages, the superheterodyne has an overwhelming advantage over the t.r.f. type of receiver because of what is commonly known as *arithmetical selectivity*.

This can best be illustrated by considering two receivers, one of the t.r.f. type and one of the superheterodyne type, both attempting to receive a desired signal at 10,000 kc. and eliminate a strong interfering signal at 10,010 kc. In the t.r.f. receiver, separating these two signals in the tuning circuits is practically impossible, since they differ in frequency by only 0.1 per cent. However, in a superheterodyne with an intermediate frequency of, for example, 1000 kc., the desired signal will be converted to a frequency of 1000 kc. and the interfering signal will be converted to a frequency of 1010 kc., both signals appearing at the input of the i.f. amplifier. In this case the two signals may be separated much more readily, since they differ by 1 per cent, or ten times as much as in the first case.

Mixer Circuits. The most important single section of the superheterodyne is the *mixer*. No matter how much signal is applied to the mixer, if the signal is not converted to the intermediate frequency and passed on to the i.f. amplifier it is lost. The tube manufacturers have released a large variety of special tubes for mixer applications and these, as well as improved circuits with older type tubes, have resulted in highly efficient mixer arrangements in present-day receivers.

Figure 10 shows several representative mixer-oscillator circuits. At "A" is illustrated *control-grid injection* from an electron-coupled oscillator to the mixer. The mixer tube for this type of circuit is usually a remote-cut-off pentode of the 57-6J7 type. The coupling condenser, C, between the oscillator and mixer is quite small, usually 1 or 2 μ fd.

This same circuit may be used with the oscillator output being taken from the oscillator grid or cathode. The only disadvantage to this method is that interlocking, or "pulling," between the mixer and oscillator tuning controls is liable to take place. A rather high value of cathode resistor (10,000 to 50,000 ohms) is usually used with this circuit.

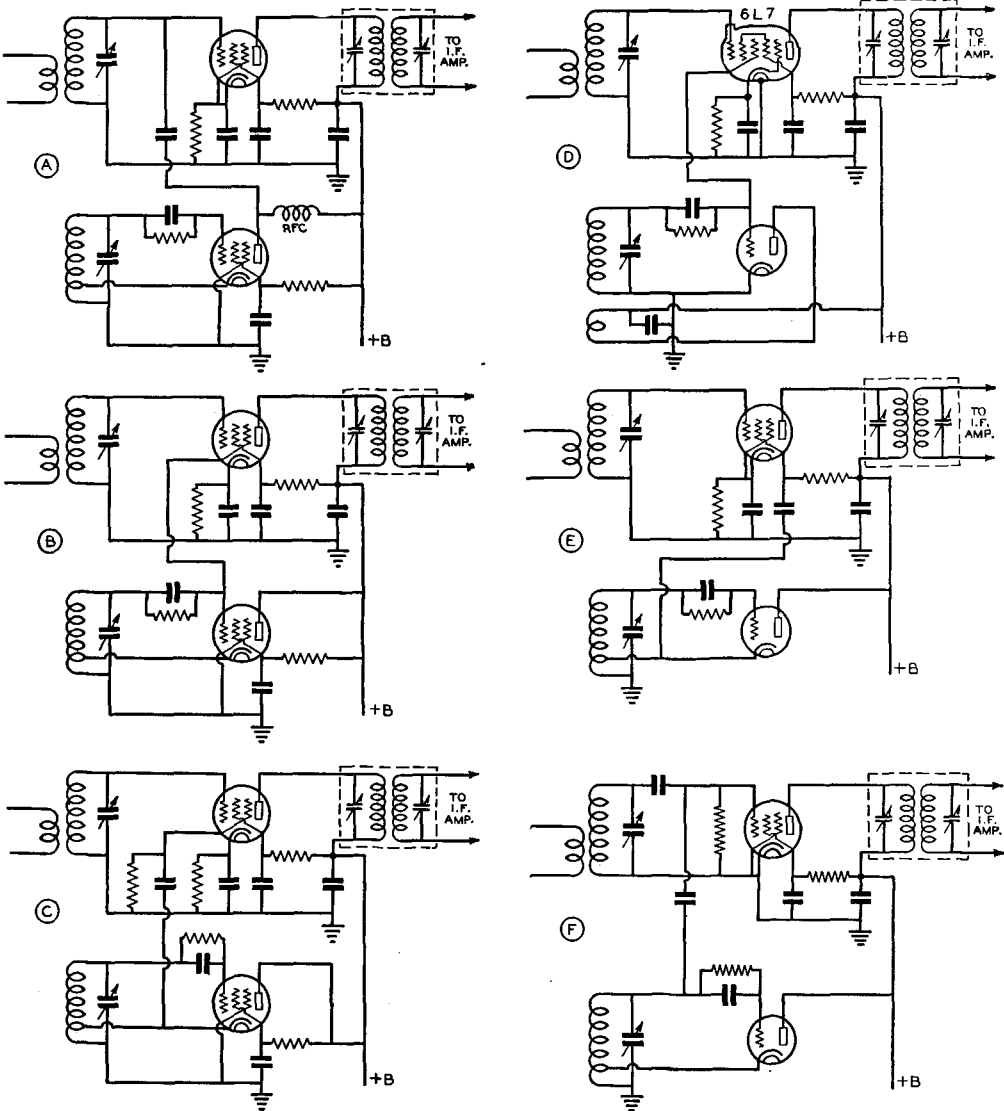

Figure 10.

MIXER-OSCILLATOR COMBINATIONS.

The various oscillators do not have to be used with the mixers with which they happen to be shown. The triode oscillator shown at E could replace the pentode circuit shown at B, for instance.

Injection of oscillator voltage into mixer elements other than the control grid is illustrated by figures 10B, C, D and E. The circuit of 10B shows injection into the suppressor grid of the mixer tube. The suppressor is biased negatively by connecting it directly to the grid of the oscillator.

An alternative method of obtaining bias for the suppressor, and one which is less prone

to cause interlocking between the oscillator and mixer is shown in figure 10C. In this circuit the suppressor bias is obtained by allowing the rectified suppressor-grid current to flow through a 50,000- or 100,000-ohm resistor to ground. The coupling condenser between oscillator and mixer may be 50 or 100 $\mu\mu\text{fd.}$ with this circuit, depending upon the frequency. Output from the oscillator may be

taken from the cathode instead of the grid end of the coil, as shown, if sufficient oscillator output is available. Mixer cathode resistors having values between 500 and 5000 ohms are ordinarily used with the circuits of 10B and C.

The mixer circuit shown in 10D is similar in appearance to that of 10B. The difference in the two lies in the type of tube used as a mixer. The 6L7 shown in 10D is especially designed for mixer service. It has a separate shielded *injector grid*, by means of which voltage from the oscillator may be injected. This circuit permits the same variations as the suppressor-injection system in regard to the method of connection into the oscillator circuit. The 6L7 requires rather high screen voltage and draws considerable screen current, and for these reasons the screen-dropping resistor is usually made around 10,000 or 15,000 ohms, which is considerably less than the values of 50,000 to 100,000 ohms used with most other mixer tubes.

Figure 10E shows injection into the mixer screen grid. When connected in the manner shown, a rather large (.01 to 0.1 μ fd.) coupling condenser may be used. This circuit is liable to cause rather bad pulling at high frequencies as there is no electrostatic shielding within the mixer tube between the screen grid and the control grid. A variation of this circuit in which the pulling effect is reduced considerably consists of using an electron-coupled oscillator circuit similar to that shown in 10A and connecting the plate of the oscillator and the screen of the mixer directly together. A voltage of about 100 volts is then applied to both the oscillator plate and the mixer screen.

E.C.O. Harmonics. One disadvantage to the use of an electron-coupled type oscillator with the output taken from the plate, which should be borne in mind by the constructor, is that due to the fact that the untuned plate circuit of the e.c. oscillator contains a large amount of harmonic output, considerable selectivity must be used ahead of the mixer to prevent the harmonics of the oscillator from beating with undesired signals at higher frequencies and bringing them in along with the desired signal. If it is desired to use an e.c. type oscillator to secure receiver stabilization in regard to voltage changes it will usually be found best to take the oscillator output from the tuned grid circuit, where the harmonic content is low. The plate of the oscillator tube may be by-passed directly to ground when this arrangement is used.

Improved Control-Grid Injection. In figure 10F an improved control-grid injection type mixer circuit is shown. This circuit al-

lows peak mixer conversion transconductance under wide variations in oscillator output. The bias on the mixer is automatically maintained at the correct value through the use of grid-leak bias, rather than by the more common cathode bias arrangement. The mixer grid leak should have a value of from 3 to 5 megohms. As in the circuit shown at 10A, the coupling condenser should be quite small—on the order of 1 or 2 μ fd. It is absolutely essential that a rather high value of series screen dropping resistor be used with this circuit to limit the current drawn by the mixer tube in case the oscillator injection voltage, and consequently the mixer bias, is inadvertently removed. The value of the screen resistor will probably lie around 100,000 ohms or above, depending upon the type of mixer tube and the available plate voltage. The resistor value should be determined experimentally by using a value which limits the mixer cathode current when the oscillator is not operating to the maximum permissible current specified by the tube manufacturer.

The different oscillator circuits shown in figure 10 are not necessarily limited to use with the mixers with which they happen to be shown. Almost any oscillator arrangement may be used with a particular mixer circuit. Examples of some of the possible combinations will be found in Chapter 6.

Converter Tubes. There is a series of *pentagrid converter* tubes available in which the functions of the oscillator and mixer are combined in a single tube. Typical of these tubes are the 6A7, 6A8, and 6SA7. The term *pentagrid* has been applied to these tubes because they have 5 grids, one of the extra grids being used as grid and the other as the anode for the oscillator section of the circuit. Suitable circuits for use with these tubes are shown in figure 11A and 11B.

Dual Unit Converters. Another set of combination tubes known as *triode-heptodes* and *triode-hexodes* is also available for use as combination mixers and oscillators. These tubes are exemplified by the 6J8G and the 6K8; they get their name from the fact that they contain two separate sets of elements—a triode and a heptode in one case, and a triode and a hexode in the other. Representative circuits for both types of tube are shown at 11C and 11D.

Separate Oscillator. Certain of the combination mixer-oscillator tubes make exceptionally good high frequency mixers when their oscillator section is left unused and the oscillator section grid is connected to a separate oscillator capable of high output. The

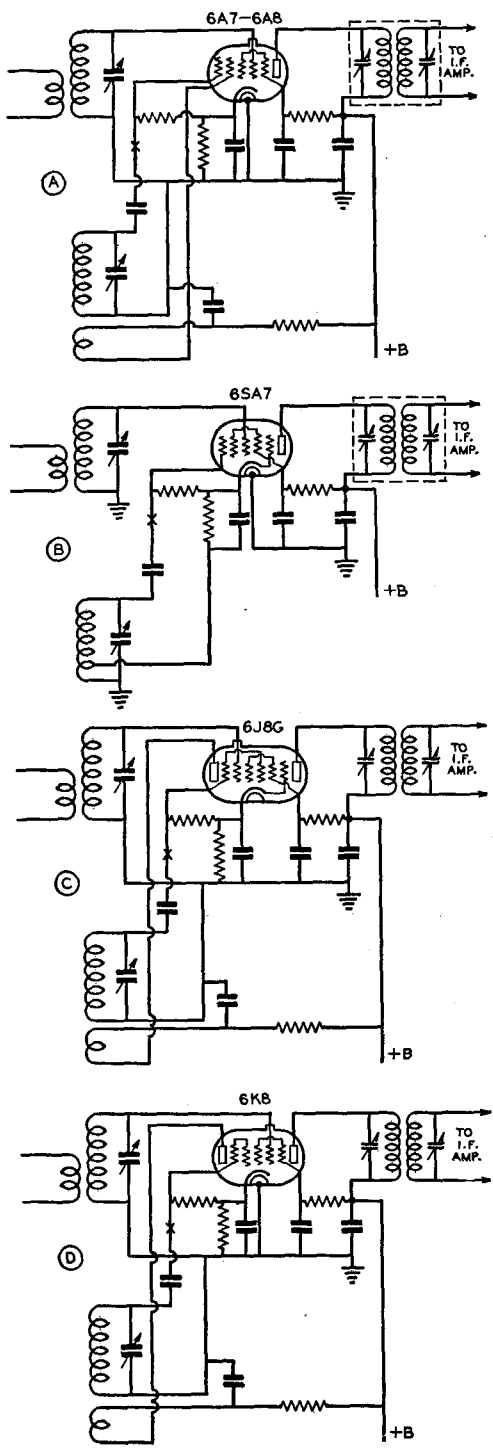

Figure 11.
CONVERTER CIRCUITS.
 A and B are for "pentagrid" tubes and C and D for "triode-heptode" and "triode-hexode" tubes.

6K8, 6J8G and 6SA7 perform particularly well when used in this manner. A circuit of this type for use with a 6K8 is shown in figure 12. The points marked "X" in figure 11 show the proper place to inject r.f. from a separate oscillator with the other combination type converter tubes. When the 6A7 and 6A8 types are used with a separate oscillator the unused oscillator anode-grid is connected directly to the screen.

Mixer Noise and Images

The effects of *mixer noise* and *images* are troubles common to all superheterodynes, and since both these effects can largely be obviated by the same remedy, they will be considered together.

Mixer Noise. Mixer noise of the shot-effect type, which is evidenced by a hiss in the audio output of the receiver, is caused by exceedingly small irregularities in the plate current in the mixer stage. Noise of an identical nature is generated in the amplifier stages of the receiver, but due to a certain extent to the fact that the gain in the mixer stage is considerably lower than in an amplifier stage using the same tube, the proportion of inherent noise present in a mixer usually is considerably greater than in an amplifier stage.

Although this noise cannot be eliminated, its effects can be greatly minimized by placing sufficient signal-frequency amplification having a high signal-to-noise ratio ahead of the mixer. This remedy causes the signal output from the mixer to be large in proportion to the noise. Increasing the gain after the mixer will be of little advantage in eliminating mixer noise difficulties; greater selectivity after the mixer will help to a certain extent but cannot be carried too far since this type of selectivity decreases the i.f. bandpass and reduces the strength of the high-frequency components of modulated signals.

Images. Images are a result of frequency conversion. They are a consequence of the fact that there are two signal frequencies which will combine with a single oscillator frequency to produce the same difference frequency. For example: a superheterodyne with its oscillator operating on a higher frequency than the signal, which is common practice in present superheterodynes, is tuned to

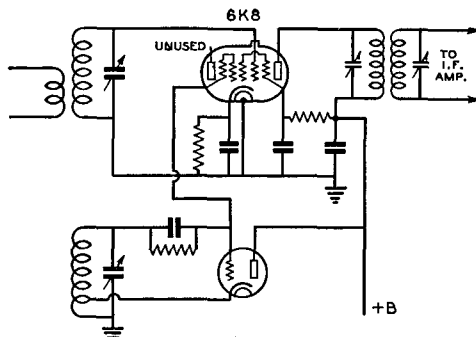

Figure 12.
USING A SEPARATE OSCILLATOR WITH
A DUAL-PURPOSE CONVERTER TUBE.

A separate oscillator may also be connected into the mixer circuits shown in figure 11 at the points marked "X."

receive a signal at 14,100 kc. Assuming an i.f.-amplifier frequency of 450 kc., the mixer input circuit will be tuned to 14,100 kc. and the oscillator to 14,100 plus 450, or 14,550 kc. Now, a strong signal at the oscillator plus the intermediate frequency (14,550 plus 450, or 15,000 kc.) will also give a difference frequency of 450 kc. in the mixer output and will be received just as though it were actually on 14,100 kc., the frequency of the desired signal. The image is always *twice* the intermediate frequency away from the desired signal.

The only way that the *image* could be eliminated in this particular case would be to make the selectivity of the mixer input circuit and any circuits preceding it great enough so that the 15,000-kc. signal would be eliminated with these circuits tuned to 14,100 kc.

For any particular intermediate frequency, image interference troubles become increasingly greater as the frequency to which the signal-frequency portion of the receiver is tuned is increased. This is due to the fact that the percentage difference between the desired frequency and the image frequency decreases as the receiver is tuned to a higher frequency. The ratio of strength between a signal at the image frequency and a signal at the frequency to which the receiver is tuned required to give equal output is known as the *image ratio*. The higher this ratio, the better the receiver in regard to image-interference troubles.

With but a single tuned circuit between the mixer grid and the antenna, and with 400-500 kc. i.f. amplifiers image ratios of one hundred and over are easily obtainable up to frequencies around 5000 kc. Above this frequency greater selectivity in the mixer grid circuit

(through the use of regeneration) or additional tuned circuits between the mixer and the antenna are necessary if a good image ratio is to be maintained.

R.F. Stages. Since the necessary tuned circuits between the mixer and the antenna can be combined with tubes to form r.f. amplifier stages, the reduction of the effects of mixer noise and the increasing of the image ratio can be accomplished in a single section of the receiver. When incorporated in the receiver this section is known simply as an *r.f. amplifier*; when it is a separate unit with a separate tuning control it is known as a *pre-selector*. Either one or two stages are commonly used in the preselector or r.f. amplifier. Some single-stage preselectors and a few two-stage units use regeneration to obtain still greater amplification and selectivity.

Double Conversion. As previously mentioned, the use of a higher intermediate frequency will also improve the image ratio, at the expense of i.f. selectivity, by placing the desired signal and the image farther apart. To give both good image ratio at the higher frequencies and good selectivity in the i.f. amplifier, a system known as *double conversion* is sometimes employed. In this system the incoming signal is first converted to a rather high intermediate frequency, such as 1600 kc., and then amplified and again converted, this time to a much lower frequency, such as 175 kc. The first i.f. frequency supplies the necessary wide separation between the image and the desired signal while the second one supplies the bulk of the i.f. selectivity.

Regenerative Preselectors. R.f. amplifiers for wave-lengths down to 30 meters can be made to operate efficiently in a nonregenerative condition. The amplification and selectivity are ample over this range. For higher frequencies, on the other hand (wave-lengths below 30 meters), *controlled regeneration* in the r.f. amplifier is often desirable for the purpose of increasing the gain and selectivity.

The input impedance of the grid circuit of a radio-frequency amplifier tube consists of a very high capacitive reactance which becomes part of the tuning capacity for longer wave-lengths. However, in very short wave receivers the input impedance of a tube may drop to very low values, such as a few thousand ohms. This low impedance across the input tuned circuit reduces the amount of amplification that can be obtained from the complete r.f. stage to a very low value.

A small amount of r.f. feedback can be introduced to compensate for this tube loss.

Regeneration can be carried to the point of actually creating the effect of negative resistance in the grid circuit, and thereby balancing the resistance introduced across the tuned circuit by the relatively low parallel tube resistance. Excessive regeneration will result in too much negative resistance, which will cause the r.f. amplifier to oscillate. Operation should always be below the point of self-oscillation.

As previously discussed, a disadvantage of the regenerative r.f. amplifier is the need for an additional regeneration control, and the difficulty of maintaining alignment between this circuit and the following tuned circuits. Resonant effects of antenna systems usually must be taken into account; a variable antenna coupling device can sometimes be used to compensate for this effect, however. Another disadvantage is the increase in hiss, or internal noise.

The reason for using regeneration at the higher frequencies and not at the medium and low frequencies can be explained as follows: The signal-to-noise ratio (output signal) of the average r.f. amplifier is reduced slightly by the incorporation of regeneration, but the signal-to-noise ratio of the receiver as a whole is improved at the very high frequencies because of the extra gain provided ahead of the mixer, this extra gain tending to make the signal output a larger portion of the total signal-plus-noise output of the receiver.

Signal-Frequency Tuned Circuits

The signal-frequency tuned circuits in superheterodynes and tuned radio frequency types of receivers consist of coils of either the solenoid or universal-wound types shunted by variable condensers. It is in these tuned circuits that the causes of success or failure of a receiver often lie. The universal-wound type coils usually are used at frequencies below 2000 kc.; above this frequency the single-layer solenoid type of coil is more satisfactory.

Impedance and Q. The two factors most affecting the tuned circuits are impedance and Q , which, as explained in Chapter 2, is the ratio of reactance to resistance in the circuit. Since the resistance of modern condensers is low at ordinary frequencies, the resistance usually can be considered to be concentrated in the coil. The resistance to be considered in making Q determinations is the r.f. resistance, not the d.c. resistance of the wire in the coil. The latter ordinarily is low enough that it may be neglected. This r.f. resistance is influenced by such factors as wire size and type and

the proximity of metallic objects or poor insulators, such as coil forms with high losses. It may be seen from the curves shown in Chapter 2 that higher values of Q lead to better selectivity and increased r.f. voltage across the tuned circuit. The increase in voltage is due to an increase in the circuit impedance with the higher values of Q .

Frequently it is possible to secure an increase in impedance in a resonant circuit, and consequently an increase in gain from an amplifier stage, by increasing the reactance through the use of larger coils and smaller tuning condensers (higher L/C ratio). The Q of the coil probably will be lowered by this process, but the impedance, which is a function of both reactance and Q , will be greater because for small increases in reactances the reactance will increase faster than the Q decreases. The selectivity will be poorer, but in superheterodyne receivers selectivity in the signal-frequency circuits is of minor importance where signals on adjacent channels are concerned. On the other hand, the t.r.f. type of receiver requires good selectivity in the tuned circuits, and a compromise between impedance and Q must be made.

Input Resistance. Another factor which influences the operation of tuned circuits is the decrease with increasing frequency of input resistance of the tubes placed across these circuits. At broadcast frequencies the input resistance of most tubes is high enough so that it is not bothersome. As the frequency is increased, however, the input resistance becomes lower because the transit time required by an electron traveling between the cathode and grid becomes an appreciable portion of the time required for an r.f. cycle of the signal voltage. The result of this effect is similar to that which would be caused by placing a resistance between the grid and cathode.

Because of the lower input resistance of tubes at the higher frequencies, there is a limit to the maximum impedance necessary to obtain maximum voltage across the tuned circuits when these circuits are shunted by the tube's input resistance. These considerations often make it advisable to design the concentric tuned circuits often used at the higher frequencies for maximum Q rather than for maximum impedance. The tube input resistance remains constant, and increasing the tuned circuit impedance beyond two or three times the input resistance will have but little effect on the net grid-to-ground impedance of the amplifier stage.

The limiting factor in r.f. stage gain is the ratio of input conductance to the tube transconductance. When the input conductance

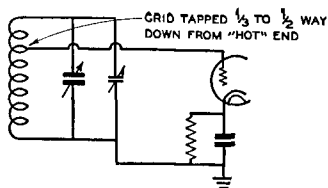

Figure 13.
CIRCUIT FOR REDUCING GRID LOADING EFFECTS.

Tapping the grid down on the coil will increase the gain and selectivity obtained with high-transconductance tubes at high frequencies.

becomes so great that it equals the transconductance, the tube no longer can act as an amplifier. There are two ways of increasing the ratio of transconductance to input conductance. One of these methods is exemplified by the "acorn" type tube, in which the input conductance is reduced through the use of a smaller element structure while the transconductance remains nearly the same as that of tubes ordinarily used at lower frequencies. Another method of accomplishing an increase in transconductance-input conductance ratio is by greatly increasing the transconductance at the expense of a proportionately small increase in input conductance. The latter method is exemplified by the so-called "television pentodes," which have extremely high transconductance and an input conductance several times that of the acorn tubes.

The difficulties presented by input-resistance effects may be partially obviated by tapping the grid down on the coil, as shown in figure 13. This circuit is commonly employed with high-transconductance tubes when operating on the 28-30 Mc. amateur band, and nearly always with such tubes on the 56-60 Mc. band. Acorn tubes, due to their smaller dimensions and lower capacities, are considerably better than the conventional types at ultra-high frequencies and it usually will not be found necessary to tap their grids down on the tuned circuit until frequencies around 200 Mc. are reached.

Superheterodyne Tracking. Because the detector (and r.f. stages, if any) and the oscillator operate on different frequencies in superheterodynes, in some cases it is necessary to make special provisions to allow the oscillator to track with the other tuned circuits when similar tuning condensers are used. The usual method of obtaining good tracking is to operate the oscillator on the high-frequency side of the mixer and use a series "tracking condenser" to slow down the tuning rate of the oscillator. The oscillator tuning rate must be slower because it covers a smaller range than

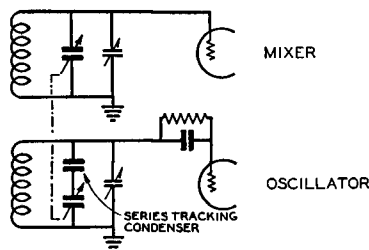

Figure 14.
OSCILLATOR SERIES TRACKING CONDENSER ARRANGEMENT.

The series condenser allows the oscillator to tune at a slower rate of capacity change than the mixer.

does the mixer when both ranges are expressed as a percentage of frequency. At frequencies above 7000 kc. and with ordinary i.f. frequencies, the difference in percentage between the two tuning ranges is so small that it may be disregarded in receivers designed to cover only a small range, such as an amateur band.

A mixer and oscillator tuning arrangement in which a series tracking condenser is provided is shown in figure 14. The value of the tracking condenser varies considerably with different intermediate frequencies and tuning ranges, capacities as low as .0001 μ fd. being used at the lower tuning-range frequencies, and values up to .01 μ fd. being used at the higher frequencies.

Bandsread Tuning. The frequency to which a receiver responds may be varied by changing the size of either the coils or the condensers in the tuning circuits, or both. In short-wave receivers a combination of both methods is usually employed, the coils being changed from one band to another and variable condensers being used to tune the receiver across each band. In practical receivers, coils may be changed by one of two methods: A switch, controllable from the front panel, may be used to switch coils of different sizes into the tuning circuits or, alternatively, coils of different sizes may be plugged manually into the receiver, the connection into the tuning circuits being made by suitable plugs on the coils. Where there are several "plug-in" coils for each band they are sometimes arranged on a single mounting strip, allowing them all to be plugged in simultaneously.

In receivers using large tuning condensers to cover the short-wave spectrum with a minimum of coils, tuning is liable to be quite difficult owing to the large frequency range covered by a small rotation of the variable condensers. To alleviate this condition, some

method of slowing down the tuning rate, or *bandspreading* must be used.

Quantitatively, bandspread is usually designated as being inversely proportional to the range covered. Thus, a *large* amount of bandspread indicates that a *small* frequency range is covered by the bandspread control. Conversely, a *small* amount of bandspread is taken to mean that a *large* frequency range is covered by the bandspread dial.

Types of Bandspread. Bandspreading systems are of two general types: electrical and mechanical. Mechanical systems are exemplified by high-ratio dials in which the tuning condensers rotate much more slowly than the dial knob. In this system there is often a separate scale or pointer either connected or geared to the dial knob to facilitate accurate dial readings. However, there is a limit to the amount of mechanical bandspread which can be obtained in an inexpensive dial before the speed-reduction unit develops backlash, which makes tuning difficult. To overcome this problem most receivers employ a combination of both electrical and mechanical bandspread. In this system a moderate reduction in the tuning is obtained in the dial and the rest of the reduction obtained by *electrical bandspreading*.

Parallel Bandspread. Electrical bandspreading takes two general forms. In one, two tuning condensers are used in parallel across each coil, one of rather high capacity to cover a large tuning range and another of small capacity to cover a small range around the frequency to which the large condenser is set. These condensers are usually controlled by separate dials or knobs, the large condenser being known as the *bandsetting* condenser, and the smaller one being the *bandspread* condenser. Where there is more than one tuned circuit in the receiver, a bandsetting and a bandspread condenser are used across *each* coil and all the condensers serving in each capacity are mechanically connected together, or *ganged*, thus allowing a single dial to be used for each purpose even though there may be several tuned circuits.

Since the tuning range of a tuned circuit is proportional to the ratio of minimum to maximum capacity across it, a wide variation in the amount of bandspreading is made possible by a proper choice of the two capacities. The greater the capacity of the bandsetting condenser in proportion to the bandspread condenser, the greater will be the bandspread.

The bandspreading method described above is usually known as the *parallel* system. This system, as applied to a single tuned circuit, is diagrammed in figure 15A. The large tun-

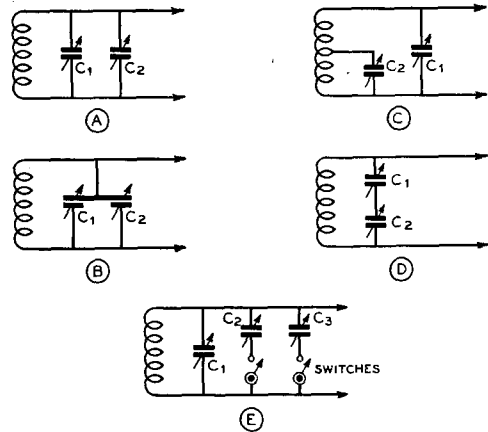

Figure 15.
BANDSPREAD CIRCUITS.

The operation of each of these circuits is described in the text.

ing, or bandsetting, condenser, C_1 , usually has a maximum capacity of from 100 to 370 μmfd . C_2 , the bandspread condenser, usually has a value of from 10 to 50 μmfd ., depending upon the design of the receiver.

Dual-Rotor Bandspread. A special form of the parallel bandspread method is used in some manufactured tuning assemblies. In this system a single set of stationary plates (stator) in the tuning condenser is acted upon by two separate rotors, one of large capacity for bandsetting and the other of small capacity for bandspread. Each rotor is operated by a separate dial. This system allows the bandsetting and bandspread functions to be combined in a single tuning-condenser unit. A variation of this method is sometimes used in which the same dial is used for both bandsetting and bandspreading purposes, the change from one function to the other being accomplished by a "gear-shifting" mechanism built into the dial. The schematic of this bandspread system is shown in figure 15B.

The parallel system of bandspreading has one major disadvantage, especially for amateur-band usage. This disadvantage lies in the fact that if the bandspreading condenser is made large enough to cover the lower-frequency amateur bands with optimum capacity being used across the coil in the bandsetting condenser, an extremely large bandsetting condenser is needed to give an equal amount of bandspread on the high-frequency bands. The high capacity across the coils reduces the impedance of the tuned circuits on the high-frequency bands, where impedance is most needed.

Tapped-Coil System. To allow equal bandspread on the amateur bands and still not use extremely high bandsetting capacities on the higher frequencies, the variation of the parallel system shown in figure 15C is often employed. As the bandspread condenser is connected across part of the coil, this method is usually known as the *tapped coil* system.

The theory upon which the tapped-coil system operates is quite simple. The effectiveness of the bandspread condenser in tuning the coil depends upon the amount of the coil included across the bandspread condenser terminals. As the number of turns between the bandspread condenser terminals is decreased the amount of bandspread increases.

In most amateur-band receivers employing the tapped-coil system of bandspreading, a separate bandsetting condenser is permanently connected across each coil. These condensers are either mounted within the coils, in the plug-in-coil system, or alongside the coils in the bandswitching system.

The tapped-coil bandspread method is quite widely used in modern amateur-band receivers, especially in home constructed sets. Its principal advantage is that it allows equal bandspread, to any degree desired, over several amateur bands. Another advantage is that it facilitates accurate tracking in ganged tuning circuits; the coil taps are adjusted until the circuits track identically.

The bandspread condenser, C_2 , may have a maximum capacity of from 25 to 50 $\mu\text{mfd.}$ for amateur band usage, while the bandsetting condenser, C_1 , should have a maximum capacity of 30 to 150 $\mu\text{mfd.}$ for amateur bands from 10 to 160 meters. Although it is possible to use almost any combination of capacities at C_1 and C_2 , too little capacity at C_1 is liable to lead to cross modulation and image interference, while too great a capacity at C_2 will cause uneven bandspread, the high-frequency end of the tuning range being more crowded than the low-frequency end.

Series System. Another bandspread system is shown in figure 15D. This system, which was widely used in the past, and is still employed to some extent, is known as *series bandspread*. In this system the bandspread condenser, C_2 , usually has a capacity of 100 to 150 $\mu\text{mfd.}$, while the bandsetting condenser, C_1 , may have a capacity of 25 to 50 $\mu\text{mfd.}$ The principle upon which the circuit operates is that while the *minimum* capacity across the coil varies but little for any setting of the bandsetting condenser, the *maximum* capacity available may be varied considerably.

Condenser Switching System. In figure 15E is illustrated another method of equalizing the degree of bandspread over a wide range of frequencies. C_1 is the large 350- $\mu\text{mfd.}$ tuning condenser; two bandspread condensers C_2 and C_3 , of 50 $\mu\text{mfd.}$ and 15 $\mu\text{mfd.}$ respectively, are switched across the large condenser for bandspreading the short-wave bands. The 50- $\mu\text{mfd.}$ condenser is suitable for bandspread tuning in the range from 75 to 200 meters, and the smaller condenser is suitable from 10 to 75 meters. The disadvantage of this circuit lies in the switching arrangement, which may require relatively long connecting leads; the minimum capacity of the circuit would then be rather high, and the lumped inductance low at the higher frequencies.

Circuit Capacity. In this book and in other radio literature mention is sometimes made of "stray" or *circuit capacity*. This capacity is in the usual sense defined as the capacity remaining across a coil when all the tuning, bandspread, and padding condensers across the circuit are at their minimum capacity setting. Circuit capacity can be attributed to two general sources. One source, which is fixed for any particular type of tube, is that due to the "cold" input capacitance of the tube when its cathode is not heated. The input capacitance varies somewhat from the fixed value when the tube is in actual operation. Such factors as plate load impedance, grid bias, and frequency will cause a change in input capacitance. However, in all except the extremely high-transconductance tubes the published measured input capacitance is quite close to the effective value. In the high-transconductance types however, the effective capacitance does vary considerably from the published figures, under different operating conditions.

The second source of circuit capacity and that which is more easily controllable is that contributed by the minimum capacity of the variable condensers across the circuit and that due to capacity between the wiring and ground. In well-designed high-frequency receivers every effort is made to keep this portion of the circuit capacity at a minimum, since a large capacity reduces the tuning range available with a given coil and prevents a good L/C ratio, and consequently a high-impedance tuned circuit, from being obtained.

Typical values of circuit capacity may run from 10 to 75 $\mu\text{mfd.}$ in high-frequency receivers, the first figure representing concentric-line receivers with acorn tubes and extremely small tuning condensers, and the

latter representing all-wave sets with band-switching, large tuning condensers, and conventional tubes.

I.F. Tuned Circuits

All i.f. amplifiers employ bandpass circuits of some sort. A bandpass circuit is exactly what the name implies—a circuit for passing a band of frequencies. Bandpass arrangements can be designed for almost any degree of selectivity, the type used in any particular application depending upon the use to which the i.f. amplifier is to be put.

Bandpass Circuits. Bandpass circuits consist essentially of two or more tuned circuits and some method of coupling the tuned circuits together. Some representative arrangements are shown in figure 16. The circuit shown at A is the conventional i.f. transformer with the coupling, M , between the tuned circuits being provided by inductive coupling from one coil to the other. As the coupling is increased, the selectivity curve becomes less peaked, and when a condition of over-coupling is reached the top of the curve flattens out. When the coupling is increased still more, a dip occurs in the top of the curve. The windings for this type of i.f. transformer, as well as most others, nearly always consist of small, flat universal-wound pies mounted either on a piece of dowel to provide an air core or on powdered-iron impregnated bakelite for "iron core" i.f. transformers. The iron-core transformers generally have somewhat more gain and better selectivity than equivalent air-core units between 175 and 2000 kc.

The circuits shown at B and C are quite similar. Their only difference is the type of mutual coupling used, an inductance being used at B and a capacitance at C. The operation of both circuits is similar. Three resonant circuits are formed by the components. In B, for example, one resonant circuit is formed by L_1 , C_1 , C_2 , and L_2 all in series. The frequency of this resonant circuit is just the same as that of a single one of the coils and condensers, since the coils and condensers are similar in both sides of the circuit and the resonant frequency of the two condensers and the two coils all in series is the same as that of a single coil and condenser. The second resonant frequency of the complete circuit is determined by the characteristics of each half of the circuit containing the mutual coupling device. In B, this second frequency will be lower than the first since the resonant frequency of L_1 , C_1 and the inductance, M , or L_2 , C_2 and M is lower than that of a single

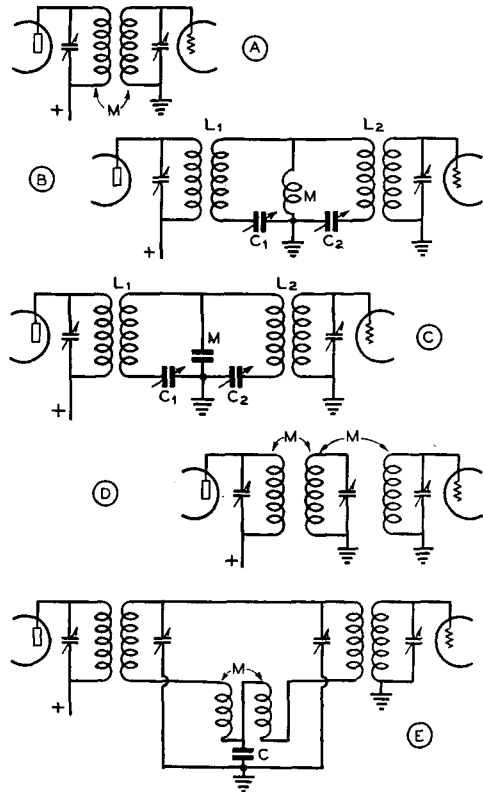

Figure 16.

I.F. AMPLIFIER BAND-PASS CIRCUITS.

The ordinary i.f. transformer circuit is shown at A. The other circuits are intended to give a straight-sided, flat-topped selectivity characteristic to the i.f. amplifier.

coil and condenser, due to the inductance of M being added to the circuit. The opposite effect takes place at C, where the common coupling impedance is a condenser. Thus at C the second resonant frequency is higher than the first. In either case, however, the circuit has two resonant frequencies, resulting in a flat-topped selectivity curve. The width of the top of the curve is controlled by the reactance of the mutual coupling component. As this reactance is increased (inductance made greater, capacity made smaller) the two resonant frequencies become farther apart and the curve is broadened.

The circuit of figure 16D is often used where a fairly high degree of bandpass action is required and the number of i.f. transformers used must be kept at a minimum. In this circuit there is inductive coupling between the center coil and each of the outer coils. The

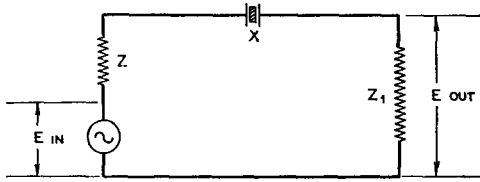

Figure 17.

CRYSTAL FILTER EQUIVALENT CIRCUIT.

With a constant input voltage, the r.f. voltage developed across Z_1 depends upon the impedances of Z , X and Z_1 .

result of this arrangement is that the center coil acts as a sharply tuned coupler between the other two. A signal somewhat off the resonant frequency of the transformer will not induce as much voltage in the center coil as will a signal of the correct frequency. When a smaller voltage is induced in the center coil, it in turn transfers a still smaller voltage to the output coil. In other words the coupling of the three coils increases as the resonant frequency is approached and remains nearly constant over a small range and then decreases again as the resonant band is passed.

Another very satisfactory bandpass arrangement which gives a very straight-sided, flat-topped curve is the negative-mutual arrangement shown at E. Energy is transferred between the input and output circuits in this arrangement by both the negative-mutual coils, M, and the common capacitive reactance, C. The negative-mutual coils are interwound on the same form and connected "backward," as shown.

Crystal Filters. The selectivity of the intermediate-frequency amplifier may be increased greatly through the use of an extremely high Q piezo-electric series resonant circuit. The piezo-electric quartz crystal, together with its coupling arrangement, is generally known as a *crystal filter*. The electrical equivalent of the basic crystal filter circuit is shown in figure 17, while the electrical equivalent of the crystal itself is shown in figure 18.

At its resonant frequency, the crystal, X, may be replaced by a very small resistance, and thus at this frequency the current flowing through the circuit, Z, X, Z_1 reaches a maximum and the output voltage E_{out} is also at its maximum value. At frequencies slightly off resonance the crystal impedance becomes quite high and the current flowing through the circuit, and consequently the voltage E_{out} developed across Z_1 , drops to a low value. It is the ratio of E_{out} at resonance

to this voltage at frequencies away from resonance that determines the selectivity characteristic of the crystal filter. This ratio may be shown to depend upon the values of the impedances Z and Z_1 . These impedances remain nearly constant for frequencies near resonance, and the selectivity of the filter circuit as a whole may be altered by changing the resonant frequency values. The variable selectivity crystal filter circuits quite often used in communications superheterodynes operate on this principle.

Practical Filters. In practical crystal filters it is necessary to balance out the capacity across the crystal holder (C_1 in figure 18) to prevent by-passing around the crystal of undesired signals off the crystal resonant frequency. The balancing is done by a *phasing* circuit which takes out-of-phase voltage from

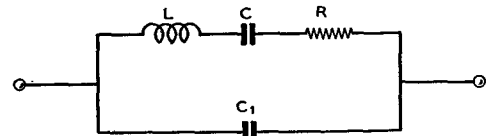

Figure 18.

CRYSTAL EQUIVALENT.

The crystal is equivalent to a very large inductance in series with a very small resistor and condenser.

Figure 19. VARIABLE-SELECTIVITY CRYSTAL CIRCUIT.

In this circuit the selectivity is at a minimum when the input circuit is tuned to resonance.

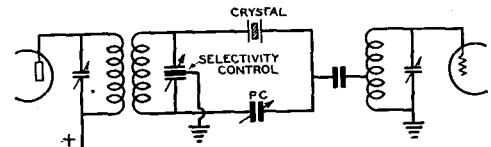

a balanced input circuit and passes it to the output side of the crystal in proper phase to neutralize that passed through the holder capacity. A representative practical filter arrangement is shown in figure 19. The phasing condenser is indicated in the diagram by PC. The balanced input circuit may be obtained either through the use of a split-stator condenser as shown or by the use of a center-tapped input coil.

Variable-Selectivity Filters. In the circuit of figure 19 the selectivity is minimum with the crystal input circuit tuned to resonance, since at resonance the input circuit is a pure resistance effectively in series with the voltage applied to the crystal. As the input

circuit is detuned from resonance, however, the resistive component of the input impedance decreases and the selectivity becomes greater. In this circuit the output from the crystal filter is tapped down on the i.f. stage grid winding to provide a better match and lower the impedance in series with the crystal.

The circuit shown in figure 20 also achieves variable selectivity by adding an impedance in series with the crystal circuit. In this case the variable impedance is in series with the crystal output circuit. The impedance of the output tuned circuit is varied by varying the Q . As the Q is reduced (by adding re-

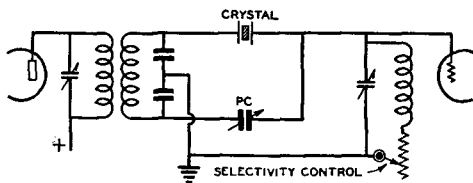
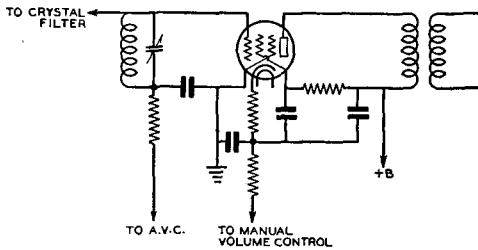

Figure 20.
WIDE-RANGE VARIABLE-SELECTIVITY
CRYSTAL FILTER.

The selectivity is varied by changing the impedance of the output circuit by changing its Q .

Figure 21.
DEGENERATIVE I.F. STAGE.

Degeneration in the i.f. stage following the crystal filter is desirable to avoid input capacity changes when the gain is varied.



sistance in series with the coil) the impedance decreases and the selectivity becomes greater.

A variation of the circuit shown at figure 20 consists of placing the variable resistance across the coil and condenser, rather than in series with them. The result of adding the resistor is a reduction of the output impedance and an increase in selectivity. The circuit behaves oppositely to that of figure 20, however; as the resistance is lowered the selectivity becomes greater.

Interference Rejection. The crystal filter phasing condenser can be adjusted so that parallel resonance between it and the crystal

causes a sharp dip in the response curve at some desired point, such as 2 kc. from the desired signal peak. This effect can be utilized to eliminate completely the unwanted sideband 1 kc. away from zero beat for c.w. reception. The b.f.o. then provides a true single signal effect, that is, a single beat frequency note. This effectively increases the number of c.w. channels that can be used in any short-wave band.

1600-Kc. Crystal Filters. Since the selectivity of a series crystal resonator varies approximately directly with frequency, crystal filters for use with i.f. amplifiers in the 1500- to 1600-kc. range are approximately three times as broad as their maximum selectivity setting as 465-kc. crystal circuits. This is no great disadvantage, as a well-designed 1600-kc. filter may be made to have 300-cycle selectivity at its maximum setting. For radiotelephone reception the 1600-kc. filter actually is advantageous, because its minimum selectivity permits a much wider band than a 465-kc. unit. The wider available pass band allows the crystal to be left in the circuit at all times and the selectivity merely varied to suit the kind of reception desired. Variable-selectivity circuits of the type shown in figure 19 require special consideration when used with 1600-kc. crystals, however. This is due to the fact that the capacity across the crystal holder, and consequently the capacity of the phasing condenser, is much higher, due to the thinner crystal required at 1600 kc.

As the phasing condenser and the crystal are actually in series across the input circuit and selectivity control, any change in setting of the phasing condenser will alter the selectivity. This difficulty may be eliminated by using a special form of phasing condenser which acts as a capacity potentiometer and maintains equal capacity across the input circuit and at the same time varies the capacity in the phasing branch.

Reducing Input Capacity Variations. As the previous discussion on crystal filters has indicated, the selectivity of the crystal filter can be altered by changing the impedance of the crystal output circuit. Since the impedance at crystal frequency of the output circuit can be varied by detuning it as well as by varying its Q , it is important that the input capacity of the tube following the filter remain constant when the gain of this stage is varied. The input capacity may be stabilized with respect to changes in the tube's amplification by employing a small amount of degeneration, as illustrated in figure 21. The amount of degeneration which can be used

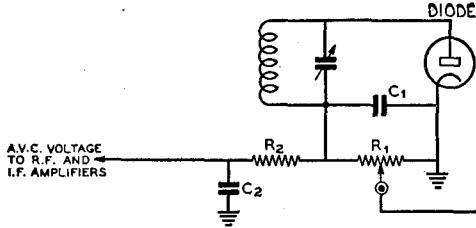

Figure 22.

DIODE A.V.C. CIRCUIT.

This circuit will be found in many superheterodynes. The diode also acts as a detector, audio voltage appearing across the volume control, R_1 .

will depend upon the amount of gain which can be sacrificed in the i.f. stage following the crystal filter. Values for R will ordinarily fall between one-third and two-thirds of the total resistance in the cathode circuit, exclusive of the manual gain control.

Detector, Audio and Control Circuits

Detectors. Second detectors for use in superheterodynes are usually of the diode, plate, or infinite impedance types, which were described in detail in Chapter 3. Occasionally, grid-leak detectors are used in receivers using one i.f. stage or none at all, when the second detector is regenerative.

Diodes are the most popular second detectors because they allow a simple method of obtaining automatic volume control to be used. Diodes load the tuned circuit to which they are connected, however, and thus reduce the selectivity slightly. Special i.f. transformers are used for the purpose of providing a low-impedance input circuit to the diode detector.

Automatic Volume Control. An elementary circuit of an automatic volume control (a.v.c.) system is shown in figure 22. A

diode tube is used as a rectifier of the carrier signal. The radio- (or intermediate) frequency circuit to the diode is completed through the small condenser C_1 , which is too low in value to by-pass audio frequencies. The carrier signal is detected or rectified, and the resulting current flows through the diode circuit and the resistance R_1 . This rectified current develops a voltage across R_1 , which is more negative at the ungrounded end.

A simple R-C (resistance-capacity) filter in the form of R_2 - C_2 may be connected to the diode circuit in order to utilize the d.c. voltage for automatic volume control purposes. The filter irons out the audio frequencies and allows pure direct current to be obtained. The negative voltage developed across R_1 and C_2 has a value directly proportional to the incoming carrier signal. This voltage is used to bias the control grids of some or all of the r.f. and i.f. amplifier stages. An increased negative bias on these stages will reduce the amplification of the receiver so that a strong carrier furnishes approximately the same audio-frequency output signal as would be obtained from a weak carrier. Automatic volume control has the further advantage of maintaining the audio signal at a fairly constant level, even though the signal from a distant station may be fading or varying in amplitude.

A great many different circuits are used for obtaining a.v.c., and it is obviously impossible to show them all here. Essentially, most of these circuits consist of some kind of rectifier for rectifying the signal and using it for bias on the preceding stages or else some sort of an amplifier biased near the cutoff point which draws more current through a resistance when a signal is applied, the drop across the resistance being used in one of several possible ways to bias the amplifier stages.

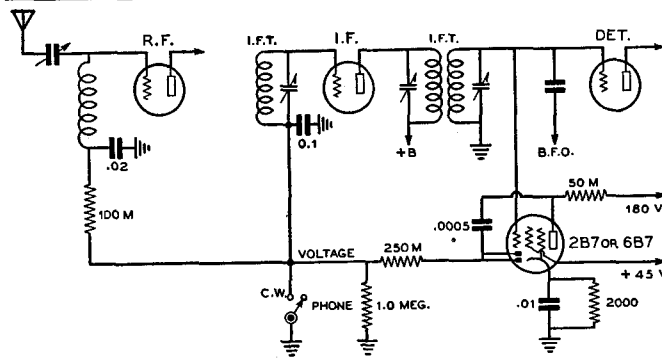

Figure 23.

A.V.C. CIRCUIT FOR ANY SUPERHETERODYNE.

This circuit may be added to a receiver not equipped with a.v.c. The 2B7 or 6B7 acts as an a.v.c. amplifier and diode rectifier.

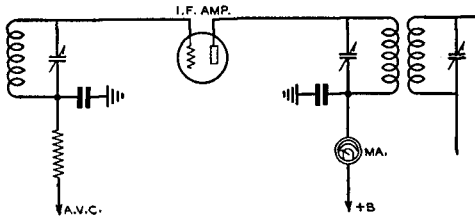

Figure 24.
USING A LOW-RANGE MILLIAMMETER AS A TUNING OR SIGNAL STRENGTH INDICATOR.

The plate current to an i.f. stage varies as the a.v.c. bias changes. A 0-10 d.c. milliammeter will serve in most cases. The meter reads "backwards" in this circuit, strong signals causing the current to decrease more than weak ones.

Figure 25.
ELECTRON-RAY TUNING INDICATOR.

Other "eye" tubes such as the 6N5, 6U5, and 6G5 may also be used in this circuit.

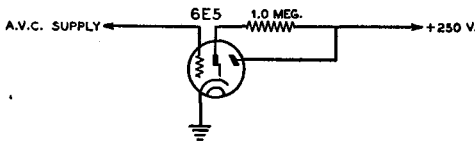

Figure 23 shows a typical automatic volume control circuit which can be applied to almost any superheterodyne receiver.

The resistors and condensers in the various i.f. and r.f. grid-return circuits constitute a time-delay filter. The time constant of the a.v.c. circuit may be reduced by using smaller condensers or resistors or increased by using larger ones.

Signal Strength Indicators. A visual means for determining whether or not the receiver is properly tuned, as well as an indication of the relative signal strength, are both provided by means of *tuning indicators* of the meter or vacuum-tube types. Direct current milliammeters can be connected in the plate return circuit of an r.f. amplifier as shown in figure 24 so that the change in plate current, due to the a.v.c. voltage which is supplied to that tube, will indicate proper tuning or *resonance*. Sometimes these d.c. meters are built in such a manner as to produce a shadow of varying width. Vacuum-tube tuning indicators are designed so that an electron-ray "eye" pattern changes its size when the input circuit of the tube is connected across all or part of the a.v.c. voltage. The basic circuit for this type of indicator is illustrated in figure 25.

Unfortunately, when an ordinary meter is used in the plate circuit of a stage for the

purpose of indicating signal strength, the meter reads backward with respect to strength. This is caused by increased a.v.c. bias on stronger signals resulting in lowered plate current through the meter. For this reason special meters which indicate zero at the right-hand end of the scale are often used for signal strength indicators in this type of circuit. Alternatively, the meter may be mounted upside down so that the needle moves toward the right with increased signal strength.

A circuit which allows an ordinary meter to be used, and which gives conventional right-hand movement of the needle with increased signal strength is shown in figure 26. The plate (or plate and screen) current to the stages receiving a.v.c. bias is fed through one-half of a bridge network. The meter, M, is usually a 0-1 milliammeter. The resistor values shown are average ones; it may be necessary to change them slightly, depending upon the number of stages drawing current through the network. Using a lower value at R will give greater "swing" for a given signal strength, while larger values will reduce the swing. The variable 1000-ohm resistor is

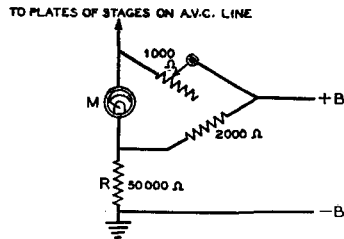
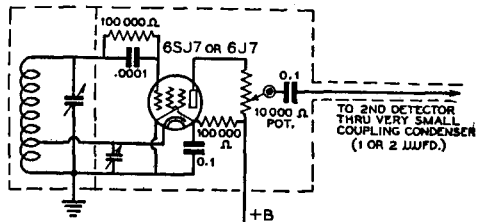

Figure 26.
FORWARD READING SIGNAL STRENGTH METER CIRCUIT.

Placing the meter in a bridge circuit allows it to read in a "forward" direction in respect to signal strength. The meter is usually a 0-1 milliammeter.

Figure 27.
VARIABLE-OUTPUT B.F.O. CIRCUIT.

Being able to vary the output of the b.f.o. is sometimes helpful when receiving weak signals.



used to set the meter for minimum indication when no signal is being received.

Beat-Frequency Oscillators. The beat-frequency oscillator, usually called the *b.f.o.*, is a necessary adjunct for reception of c.w. telegraph signals on superheterodynes which do not use regenerative detectors. The oscillator is coupled into the second detector circuit and supplies a weak signal of nearly the same frequency as that of the desired signal from the i.f. amplifier. If the i.f. amplifier is tuned to 465 kc., for example, the b.f.o. is tuned to approximately 464 or 466 kc. in order to produce a 1000-cycle beat note in the output of the second detector of the receiver. The carrier signal would otherwise be inaudible. The b.f.o. is not used for voice reception, except as an aid in searching for weak stations.

The b.f.o. input to the second detector need only be sufficient to give a good beat note on an average signal. Too much coupling into the second detector will give an excessively high hiss level, masking weak signals by the high noise background.

A method of manually adjusting the b.f.o. output to correspond with the strength of received signals is shown in figure 27. A variable b.f.o. output control of this sort is a useful adjunct to any superheterodyne, since it allows sufficient b.f.o. output to be obtained to give a "beat" with strong signals and at the same time permits the b.f.o. output, and consequently the hiss, to be reduced when attempting to receive weak signals. The circuit shown is somewhat better than those in which one of the electrode voltages on the b.f.o. tube is changed, as the latter usually change the frequency of the b.f.o. at the same time they change the strength, making it necessary to reset the trimmer each time the output is adjusted.

In nearly all receivers in which both a.v.c. and a b.f.o. are used it is necessary to disconnect the a.v.c. circuit and manually control the gain when the b.f.o. is turned on. This is because the b.f.o. acts exactly like a strong signal and puts a.v.c. bias on the stages on the a.v.c. line, thereby lowering the gain of the receiver.

Noise Suppression

The problem of noise suppression confronts the listener who is located in such places where interference from power lines, electrical appliances and automobile ignition systems is troublesome. This noise is often of such intensity as to swamp out signals from desired stations.

There are three principal methods for reducing this noise:

- (1) A.c. line filters at the source of interference if the noise is created by an electrical appliance.
- (2) Noise-balancing circuits for the reduction of power-leak interference.
- (3) Noise-limiting circuits for the reduction, in the receiver itself, of interference of the type caused by automobile ignition systems.

Power Line Filters. Numerous household appliances, such as electric mixers, heating pads, vacuum sweepers, refrigerators, oil burners, sewing machines, doorbells, etc., create an interference of an intermittent nature. The insertion of a line filter near the source of interference often will effect a complete cure. Filters for small appliances can consist of a 0.1- μ fd. condenser connected across the 110-volt a.c. line. Two condensers in series across the line, with the midpoint

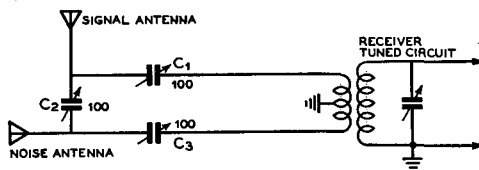

Figure 28.

JONES NOISE-BALANCING CIRCUIT.

This circuit, when properly adjusted, reduces the intensity of power-leak and similar interference.

connected to ground, can be used in conjunction with ultra-violet ray machines, refrigerators, oil burner furnaces and other more stubborn offenders. In severe cases of interference, additional filters in the form of heavy-duty r.f. choke coils must be connected in series with the 110-volt a.c. line on both sides of the line.

Noise Balancing. Power line noise interference can be greatly reduced by the installation of a *noise-balancing* circuit ahead of the receiver, as shown in figure 28. The noise-balancing circuit adds the noise components from a separate noise antenna in such a manner that this noise antenna will buck the noise picked up by the regular receiving antenna. The noise antenna can consist of a connection to one side of the a.c. line, in some cases, while at other times an additional wire, 20 to 50 feet in length, can be run parallel to the a.c. house supply line. The noise antenna should pick up as much noise as possible in comparison with the amount of signal

pickup. The regular receiving antenna should be a good-sized out-door antenna, so that the signal to noise ratio will be as high as possible. When the noise components are balanced out in the circuit ahead of the receiver, the signals will not be appreciably attenuated.

This type of noise balancing is not a simple process; it requires a bit of experimentation in order to obtain good results. However when proper adjustments have been made, it is possible to reduce the power leak noise from 3 to 5 R points without reducing the signal strength more than one R point, and in some cases there will be no reduction in signal strength whatsoever. This means that fairly weak signals can be received through terrific power leak interference. Hash type interference from electrical appliances can be reduced to a very low value by means of the same circuits.

The coil should be center-tapped and connected to the receiver ground connection in most cases. The pickup coil consists of four turns of hookup wire 2" in diameter which can be slipped over the first r.f. tuned coil in most radio receivers. A two-turn coil is more appropriate for 10- and 20-meter operation, though the four-turn coil is suitable if care is taken in adjusting the condensers to avoid 10-meter resonance (unless very loose inductive coupling is used).

Adjustment of C_1 will generally allow a noise balance to be obtained when varying C_2 and C_3 in nearly any location. One antenna, then the other, can be removed to check for noise in the receiver. When properly balanced, the usual power line buzz can be balanced down nearly to zero without attenuating the desired signal more than 50%. This may result in the reception of an intelligible distant signal through extremely bad power line noise. Sometimes an incorrect adjustment will result in balancing out the signal as well as the noise. A good high antenna for signal reception will ordinarily overcome this effect.

With this circuit some readjustment is necessary from band to band in the short-wave spectrum; noise-balancing systems require a good deal of patience and experimenting at each particular receiving location.

Noise-Limiting Circuits. Several different noise-limiting circuits have become popular. These circuits are beneficial in overcoming automobile ignition interference. They operate on the principle that each individual noise pulse is of very short duration, yet of extremely high amplitude. The popping or clicking type of noise from electrical ignition systems may produce a signal ten

to twenty times as great as the incoming radio signal.

As the duration of this type of noise peak is short, the receiver can be made inoperative during the noise peak without the human ear detecting the total loss of signal. Some noise limiters, or eliminators, actually *punch a hole* in the signal, while others merely *limit* the maximum peak signal which reaches the headphones or loudspeaker.

The noise peak is of such short duration that it would not be objectionable except for the fact that it produces an overloading effect on the receiver, which increases its time constant. A sharp voltage peak will give a kick to the diaphragm of the headphones or speaker, and the momentum or inertia keeps the diaphragm in motion until the dampening of the diaphragm stops it. This movement produces a popping sound which may completely obliterate the desired signal. If the noise peak can be limited to an amplitude equal to that of the desired signal, the resulting interference is practically negligible.

A.F. Peak Limiters. Remarkably good noise suppression can be obtained in the audio amplifier of a radio receiver by using a delayed push-pull diode suppressor. Any twin diode tube can be used, though the type 84 high vacuum full-wave rectifier tube seems to be the most effective.

The circuit in figure 29 can be used to describe the operation of this general type of noise suppressor or limiter. Each diode works on opposite noise voltages; that is, both sides of the noise voltage (+ and - portions of the a.c. components) are applied to diodes which short-circuit the load whenever the applied voltage is greater than the delay voltage. The delay bias voltage prevents diode current from flowing for low-level audio voltages, and so the noise circuit has no effect on the desired signals except during the short interval of noise peaks. This interval is usually so short that the human ear will not notice a drop in signal during the small time that the load (headphones) is short-circuited by the diodes.

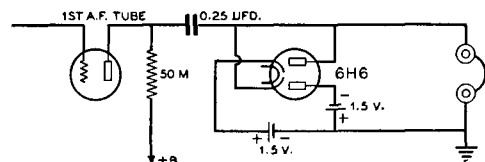

Figure 29.

A.F. NOISE LIMITER.

A limiter such as this is effective in reducing short-duration noise pulses, such as automobile ignition interference.

Delay bias voltage of $1\frac{1}{2}$ volts from a small flashlight cell will allow any signal voltage to operate the headphones which has a peak of less than about $1\frac{1}{2}$ volts. Noise peaks often have values of from 5 to 20 times as great as the desired signal; so these peaks operate the diodes, causing current to flow and a sudden drop in impedance across the headphones.

Diodes have nearly infinite impedance when no diode current is flowing; however, as soon as current starts, the impedance will drop to a very few hundred ohms, which tends to damp out or short circuit the audio output. The final result is that the noise level from automobile ignition is limited to values no greater than the desired signal. This is low enough to cause no trouble in understanding the voice or c.w. signals.

A push-pull diode circuit is necessary because the noise peaks are of an a.c. nature and are not symmetrical with respect to the zero a.c. voltage reference level. The negative peaks may be greater than the positive peaks, depending on the bias and overload characteristics of the audio amplifier tube. If a single diode is used, only the positive (or negative) peaks could be suppressed. In figure 29 the two bias dry-cells are arranged to place a negative bias on each diode plate of $1\frac{1}{2}$ volts. A positive noise voltage peak at the plate of the audio amplifier tube will overcome this negative bias on the top diode plate and cause diode current to flow and lower the impedance. A negative noise voltage peak will overcome the positive bias on the other diode cathode and cause this diode to act as a noise suppressor. A positive bias on the cathode is the same as a negative bias on the diode plate. The 6H6 has two separate cathodes and plates, hence lends itself readily to the simple circuit illustrated in figure 29.

Circuits of this type are very effective for short-pulse noise elimination because they tend to punch a hole in the signal for the duration of a strong noise voltage peak. A peak that will cause a loudspeaker or headphones to rattle with a loud pop will be reduced to a faint pop by the noise-suppression system. The delay bias prevents any attenuation of the desired signal as long as the signal voltage is less than the bias.

With this type of noise limiter it is possible to adjust the audio or sensitivity gain controls so that the auto ignition QRM seems to drop out, leaving only the desired signal with a small amount of distortion. Lower gain settings will allow some noise to get through but will eliminate audio distortion on voice or music reception. At high levels the speech

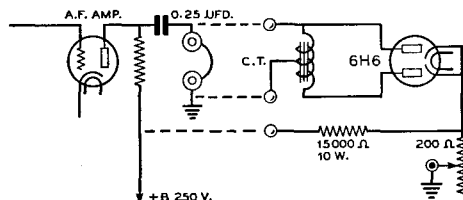

Figure 30.

ADJUSTABLE NOISE LIMITER.

With this circuit the bias on the limiter diodes is adjustable for different noise levels. The center-tapped choke may be the primary of a small pentode output transformer.

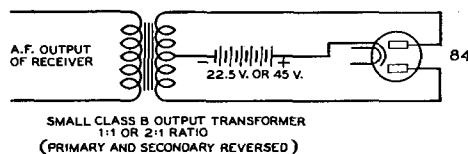

Figure 31.

NOISE LIMITER FOR USE WITH LOUDSPEAKER.

The high bias on this dual-diode noise limiter allows it to be used on high-level audio stages.

or music peaks will be attenuated whenever they exceed the d.c. delay bias voltage. Faint ignition rattle will always be audible in the background with any noise-suppressor circuit since some noise peaks are too small to operate the systems, yet are still audible as a weak rattle or series of pops in the headphones.

Figures 30 and 31 show two noise-limiter circuits which can be used as separate units for connection to any receiver. The unit shown in figure 30 can be connected across any headphone output as long as there is no direct current flowing through the phones. A blocking condenser can be connected in series with it if necessary, though better noise suppression results when the blocking condenser is in series with the plate lead to the headphones. Delay bias is obtained from the plus B supply through a 15,000-ohm 10-watt resistor and a 200-ohm wire-wound variable resistor. The cathode or cathodes are made a volt or so positive with respect to ground and minus B connection.

The diode plates are connected through a center-tapped low resistance choke to ground as far as bias voltage is concerned. Any push-pull to voice coil output transformer can be used for the center-tapped choke in figure 30. The secondary can be left open. The delay bias is adjustable from 0 up to about 3 volts and once set for some noise level, can be left in that position.

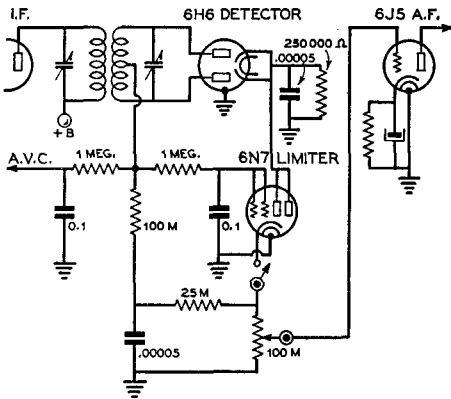

Figure 32.
DICKERT AUTOMATIC LIMITER.
This limiter will automatically adjust itself to various amounts of carrier strength. The recommended values of components are shown.

The unit illustrated in figure 31 can be connected across any audio amplifier stage, even the output stage which drives a loudspeaker. Any bias from 1½ to 90 volts or more can be connected in series with the center tap and 84 tube cathode. The higher values of delay bias would be needed for high output levels from the loudspeaker. Generally, 22½- to 45-volts bias will allow enough delay to allow moderate room volume reception of the desired voice signals without leveling off and distortion. As low a delay bias should be used as possible without distortion, in order to obtain effective noise suppression.

Second-Detector Noise Limiters. There are numerous arrangements for noise limiting in the second detector circuit. Tests conducted with a great many of these circuits have indicated that the ones shown in figures 32, 33 and 34 are the most practical and desirable for use in amateur communications receivers. The noise-silencing action of these limiters is obtained either by shorting the noise pulses to ground or by opening an "electronic switch" in series with the audio current on each noise pulse. The circuit of figure 32 is an example of the first method, while those of figures 33 and 34 are of the latter type.

The *Dickert* noise limiter circuit shown in figure 32 makes use of a diode detector and a small class B triode such as the 6A6, 6N7, or 79 as the noise limiter tube. The latter tubes are used because at zero or negative grid voltage and a small amount of plate potential they draw very little plate current.

Under normal operation with a received carrier the grid of the 6N7 is biased nega-

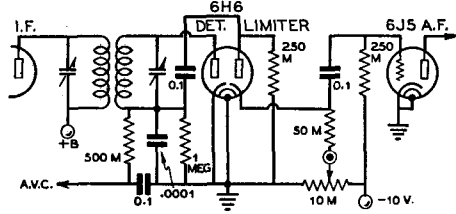

Figure 33.
BACON SERIES LIMITER.
The series type of limiter breaks the circuit between the detector and first audio stage on noise peaks.

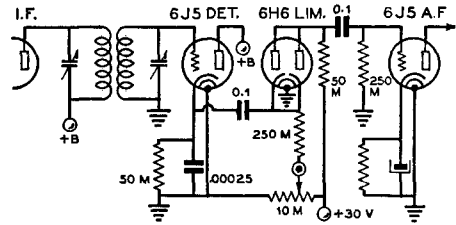

Figure 34.
SERIES LIMITER WITH INFINITE-IMPEDANCE DETECTOR.

This arrangement of the series limiter must be used when the detector gives positive output voltage. It is applicable to both infinite impedance and power detectors.

tively by an amount slightly less than half the rectified carrier voltage. This means that for modulation percentages up to nearly 100 per cent the resistance of the 6N7 will remain very high due to its grid always remaining negative with respect to the cathode. Note also that the grid is supplied with d.c. through a filter circuit with a comparatively high time constant so that the actual grid potential varies but very slowly with changing external conditions.

But with the reception of a noise pulse the cathode of the 6N7 is instantaneously driven highly negative while the control grid maintains the moderate carrier-level bias due to the time constant of the filter feeding it. Another way of stating that the cathode goes negative with respect to the grid is, of course, to say that the control grid is driven positive. Also, at the same time that the control grid goes positive the same noise pulse drives the plate of the 6N7 more positive due to the common resistance between it and the cathode of the detector, and ground. This of course means that the current due to the noise pulse flows almost entirely between the cathode and plate of the 6N7 instead of taking its normal course through the audio volume control.

The circuit is completely self-adjusting as to received carrier strength and gives equal suppression regardless of the carrier level.

Series-Valve Limiters. In the *Bacon* series-tube limiter circuits the normal signal is carried by the cathode-to-plate current of an additional diode connected into the circuit. This cathode-to-plate current can only flow as long as the plate is positive with respect to the cathode of the diode. Hence, by limiting the range of input signal voltages over which this plate current will flow in conformity with the polarity of the noise pulses as they will appear in the output of the detector, noise limiting will be obtained by adjusting the voltages to such a point that all incoming pulses greater than those produced by 100 per cent modulation of the incoming carrier will cause the plate to go negative with respect to the cathode of the noise diode. The strong noise pulses will then find an open circuit in their path from detector to audio amplifier although noise pulses up to and including the amplitude of the incoming signal (and the incoming signal) will be passed on to the audio stages.

In a conventional diode detector the noise pulses will be increasingly negative with respect to normal signal levels so it is necessary to feed the audio into the plate of the limiter diode and to run the cathode of this diode negative with respect to the plate. This arrangement is shown in figure 33. The amount of bias is adjusted manually so that all normal signal strengths will be handled but that pulses in excess of this strength will cause the plate to go negative with respect to the cathode and cause the pulse to be limited in amplitude.

In a power detector or infinite-impedance detector the noise pulses are positive with respect to normal signals. In this case it is necessary to feed the detector output into the cathode of the diode limiter and to bias the plate a certain fixed amount positive with respect to the cathode, as shown in figure 34. Then, with noise pulses which exceed the positive bias which has been manually adjusted to appear on the plate, the cathode will go positive with respect to the plate and the continuity of the signal will be stopped.

A disadvantage of all series-tube noise limiters is that the signal strength output of the detector is reduced by a considerable amount, often as much as 8 to 10 db, which sometimes requires an additional audio stage or a high-gain stage in place of a low-gain one.

A more detailed and comprehensive discussion of noise balancing and noise limiting

systems will be found in the *RADIO Noise Reduction Handbook*.

Receiver Adjustment

The simplest type of regenerative receiver requires little adjustment other than those necessary to insure correct tuning and smooth regeneration over some desired range. Receivers of the tuned radio-frequency type and superheterodynes require precise alignment to obtain the highest possible degree of selectivity and sensitivity.

Good results can only be obtained from a receiver when it is properly aligned and adjusted. The most practical technique for making these adjustments is given in the following discussion.

Instruments. A very small number of instruments will suffice to check and align any multitube receiver, the most important of these testing units being a modulated oscillator and a d.c. and a.c. voltmeter. The meters are essential in checking the voltage applied at *each* circuit point from the power supply. If the a.c. voltmeter is of the oxide-rectifier type, it can be used, in addition, as an output meter when connected across the receiver output when tuning to a modulated signal. If the signal is a steady tone, such as from a test oscillator, the output meter will indicate the value of the detected signal. In this manner, lineup adjustments may be visually noted on the meter rather than by increases or decreases of sound intensity as detected by ear.

T.R.F. Receiver Alignment. The alignment procedure in a multi-stage t.r.f. receiver is exactly the same as aligning a single stage. If the detector is regenerative, each preceding stage is successively aligned while keeping the detector circuit tuned to the test signal, the latter being a station signal or one locally generated by a test oscillator loosely coupled to the antenna lead. During these adjustments, the r.f. amplifier gain control is adjusted for maximum sensitivity, assuming that the r.f. amplifier is stable and does not oscillate. Oscillation is indicative of improper by-passing or shielding. Often a sensitive receiver can be roughly aligned by tuning for maximum noise pickup, such as parasitic oscillations originating from static or electrical machinery.

Superheterodyne Alignment. Aligning a superhet is a detailed task requiring a great amount of care and patience. It should never be undertaken without a thorough understanding of the involved job to be done and then only when there is abundant time to

devote to the operation. There are no shortcuts; every circuit must be adjusted individually and accurately if the receiver is to give peak performance. The precision of each adjustment is dependent upon the accuracy with which the preceding one was made.

Superhet alignment requires (1) a good signal generator (modulated oscillator) covering the radio and intermediate frequencies and equipped with an attenuator and B-plus switch; (2) the necessary socket wrenches, screwdrivers, or "neutralizing tools" to adjust the various i.f. and r.f. trimmer condensers, and (3) some convenient type of tuning indicator, such as a copper-oxide or electronic voltmeter.

Throughout the alignment process, unless specifically stated otherwise, the a.f. and r.f. gain controls must be set for maximum output, the beat oscillator switched off, the R-meter cut out, the crystal filter set for minimum selectivity and the a.v.c. turned off. If no provision is made for a.v.c. switching, the signal generator output must be reduced to the proper level by means of the attenuator. When the signal output of the receiver is excessive, either the attenuator or the a.f. gain control may be turned down, but never the r.f. gain control.

I.F. Alignment. After the receiver has been given a rigid electrical and mechanical inspection and any faults which may have been found in wiring or the selection and assembly of parts corrected, the i.f. amplifier may be aligned as the first step in the checking operations.

The coils for the r.f. (if any), first detector and high-frequency oscillator stages must be in place. It is immaterial which coils are inserted, since they will serve during the i.f. alignment only to prevent open-grid oscillation.

With the signal generator set to give a modulated signal on the frequency at which the i.f. amplifier is to operate, clip the output leads from the generator to the last i.f. stage; "hot" end through a small fixed condenser to the control grid, "cold" end to the receiver ground. Adjust both trimmer condensers in the last i.f. transformer to resonance as indicated by signal peak in the headphones or speaker and maximum deflection of the output meter.

Each i.f. stage is adjusted in the same manner, moving the hot lead, stage by stage, back toward the front end of the receiver and backing off the attenuator as the signal strength increases in each new position. The last adjustment will be made to the first i.f. transformer with the hot lead connected to the

control grid of the first detector. Occasionally, it is necessary to disconnect the 1st detector grid lead from the coil, grounding it through a 1,000- or 5,000-ohm grid leak and coupling the signal generator through a small capacitance to the grid.

When the last i.f. adjustment has been completed, it is good practice to go back through the i.f. channel, re-peaking all of the transformers. It is imperative that this recheck be made in sets which do not include a crystal filter and where necessarily the simple alignment of the i.f. amplifier to the generator is final.

I.F. with Crystal Filter. There are several ways of aligning an i.f. channel which contains a crystal-filter circuit. However, the following method is one which has been found to give satisfactory results in every case:

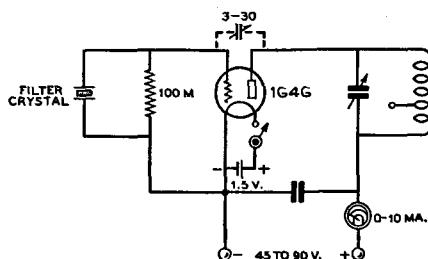

Figure 35.
CRYSTAL TEST OSCILLATOR CIRCUIT.

The receiver's crystal may be placed in this oscillator for a rough alignment of the i.f. amplifier to the crystal frequency. The tank circuit is made up of a winding from a b.f.o. transformer and a 350- μ fd. broadcast condenser.

If the i.f. channel is known to be far out of alignment or if the initial alignment of a new receiver is being attempted, the crystal itself should first be used to control the frequency of a test oscillator. The circuit shown in figure 35 can be used. A b.f.o. coil, as shown in the diagram, can be used for the plate inductance. If none is handy one winding of an i.f. transformer may be used. In either case, it is necessary to disconnect the trimmer across the winding unless it has sufficient maximum capacity to be used in place of the 350- μ fd. tuning condenser indicated in the diagram.

A milliammeter inserted in the plate circuit will indicate oscillation, the plate current dipping as the condenser tunes the inductance to the resonant frequency of the crystal. Some crystals will require additional grid-plate capacity for oscillation; if so, a 30- μ fd. mica

trimmer may be connected from plate to grid of the oscillator tube. The oscillator is then used as a line-up oscillator as described in the preceding section by using a.c. for plate supply instead of batteries. The a.c. plate supply gives a modulated signal suitable for the preliminary lining-up process.

For the final i.f. alignment the crystal should be replaced in the receiver and the phasing condenser set at the "phased" setting, if this is known. If the proper setting of the phasing condenser is unknown it can be set at half capacity to start with. Next, a signal generator should be connected across the mixer grid and ground and, with the receiver's a.v.c. circuit operating and the beat oscillator turned "off," the signal generator slowly tuned across the i.f. amplifier frequency.

As the generator is tuned through the crystal frequency, the receiver's signal strength meter will give a sudden kick. Should the receiver not be provided with a signal-strength meter, a vacuum-tube voltmeter, such as shown in Chapter 22, can be connected across the a.v.c. line; if the receiver has neither a.v.c. nor a tuning meter, the vacuum-tube voltmeter may be connected between the second detector grid and ground. In any case a kick of either the tuning meter or the vacuum-tube voltmeter will indicate crystal resonance. It is quite probable that more than one resonance point will be found if the receiver is far out of alignment. The additional points of resonance are spurious crystal peaks; the strongest peak should be chosen and the signal generator left tuned to this frequency.

The phasing condenser should next be adjusted for *minimum* hiss or noise in the receiver output and the selectivity control, if any is provided, set for maximum selectivity. From this point on, the alignment of the i.f. amplifier follows conventional practice, except that the a.v.c. circuit is used as an alignment indicator, each circuit being adjusted for maximum output. If the receiver is of the type having no a.v.c. or tuning indicator, and the vacuum-tube voltmeter must be connected across the second-detector grid circuit, it will be necessary to remove the vacuum-tube voltmeter and make the final adjustment on the last i.f. transformer by ear after the other transformers have been aligned.

B. F. O. Adjustment. Adjusting the beat oscillator is relatively simple. It is only necessary to tune the receiver to resonance with any signal, as indicated by the tuning indicator, and then turn on the b.f.o. and set its trimmer (or trimmers) to produce the desired beat note. Setting the beat oscillator in this way will result in the beat note being stronger

on one "side" of the signal than on the other, which is what is desired for maximum selectivity. The b.f.o. should *not* be set to "zero beat" with the receiver tuned to resonance with the signal as this will cause an equally strong beat to be obtained on both sides or resonance.

Front-End Alignment. The alignment of the "front end" of a manufactured receiver is a somewhat involved process and varies considerably from one receiver to another and for that reason will not be discussed here. Those interested in the alignment of such receivers usually will find full instructions in the operating manual or instruction book supplied with the receiver. Likewise full alignment data are always given when an "all wave" tuning assembly for incorporation in home-built receivers is purchased.

In aligning the front end of a home-constructed superheterodyne which covers only the amateur bands the principal problems are those of securing proper bandspread in the oscillator, and then tracking the signal-frequency circuits with the oscillator. The simplest method of adjusting the oscillator for proper bandspread is to tune in the oscillator on an "all wave" receiver and adjust its bandspread so that it covers a frequency range equal to that of the tuning range desired in the receiver but over a range of frequencies equal to the desired signal range plus the intermediate frequency. For example: If the receiver is to tune from 13,950 to 14,450 kc. to cover the 14-Mc. amateur band with a 50-kc. leeway at each end, and the intermediate frequency is 465 kc., the oscillator should tune from 13,950+465 kc. to 14,450+465 kc., or from 14,415 to 14,915 kc.

(Note: The foregoing assumes that the oscillator will be operated on the high-frequency side of the signal, which is the usual condition. It is quite possible, however, to have the oscillator on the low-frequency side of the signal, and if this is desired the intermediate frequency is simply *subtracted* from the signal frequency, rather than added, to give the required oscillator frequency).

If no calibrated auxiliary receiver is available the following procedure should be used to adjust the oscillator to its proper tuning range: A modulated signal from the signal generator is fed into the mixer grid, with mixer grid coil for the band being used in place, and with the signal generator set for the highest frequency in the desired tuning range and the bandspread condenser in the receiver set at minimum capacity, the oscillator bandsetting condenser is slowly decreased from maximum capacity until a strong signal

from the signal generator is picked up. The first strong signal picked up will be when the oscillator is on the low-frequency side of the signal. If it is desired to use this beat, the oscillator bandsetting condenser need not be adjusted further. However, if it is intended to operate the oscillator on the high-frequency side of the signal in accordance with usual practice, the bandsetting condenser should be decreased in capacity until the second strong signal is heard. When the signal is properly located the mixer grid should be next tuned to resonance by adjusting its padder condenser for maximum signal strength.

After the high-frequency end of the band has thus been located the receiver bandspread condenser should be set at maximum capacity and the signal generator slowly tuned toward the low-frequency end of its range until its signal is again picked up. If the bandspread adjustment happens to be correctly made, which is not probable, the signal generator calibration will show that it is at the low-frequency end of the desired tuning range. If calibration shows that the low-frequency end of the tuning range falls either higher or lower than what is desired, it will be necessary to make the required changes in the bandspread circuit described under the section on *Bandspread* and repeat the checking process until the tuning range is correct.

Tracking. After the oscillator has been set so that it covers the correct range, the tracking of the mixer tuning may be tackled. With the signal generator set to the high-frequency end of the tuning range and *loosely* coupled to the mixer grid the signal from the generator should be tuned in on the receiver and the mixer padding condenser adjusted for maximum output. Next, both the receiver and the signal generator should be tuned to the low-frequency end of the receiver's range and a check made to see if it is necessary to reset the mixer padder to secure maximum output. If the tracking is correct it will be found that no change in the padder capacity will be necessary. If, however, it is found that the output may be increased by retuning the padder it will be necessary to readjust the mixer bandspread.

An increase in signal strength with an increase in padding capacity indicates that the bandspread is too great and it will be necessary to increase the tuning range of the mixer. An increase in signal strength with a decrease in padding capacity shows that the mixer tuning range is too great and the bandspread will have to be increased.

When the mixer bandspread has been adjusted so that the tracking is correct at both

ends of a range as narrow as an amateur band, it may be assumed that the tracking is nearly correct over the whole band. The signal generator should then be transferred to the grid of the r.f. stage, if the receiver has one, and the procedure described for tracking the mixer carried out in the r.f. stage.

Series Tracking Condensers. The above discussion applies solely to receivers in which a small tuning range is covered with each set of coils and where the ranges covered by the oscillator and mixer circuits represent nearly equal percentages of their operating frequencies, i.e., the intermediate frequency is low. When these conditions are not satisfied, such as in continuous-coverage receivers and in receivers in which the intermediate frequency is a large proportion of the signal frequency, it becomes necessary to make special provisions for oscillator tracking. These provisions usually consist of ganged tuning condensers in which the oscillator section plates are shaped differently and have a different capacity range than those used across the other tuned circuits, or the addition of a "tracking condenser" in series with the oscillator tuning condenser in conjunction with a smaller coil.

While series tracking condensers are seldom used in home-constructed receivers, it may sometimes be necessary to employ one, as in, for example, a receiver using a 1600-ke. i.f. channel and covering the 3500-4000 ke. amateur band. The purpose of the series tracking condenser is to slow down the oscillator's tuning rate when it operates on the high-frequency side of the signal. This method allows perfect tracking at three points throughout the tuning range. The three points usually chosen for the perfect tracking are at the two ends and center of the tuning range; between these points the tracking will be close enough for all practical purposes.

In home-constructed sets the adjustment of the tracking condenser and oscillator coil inductance is largely a matter of cut-and-try, requiring a large amount of patience and an understanding of the results to be expected when the series capacity and the oscillator inductance are changed.

Receivers with A.V.C. When lining up a receiver which has automatic volume control (a.v.c.), it is considered good practice to keep the test oscillator signal near the threshold sensitivity at all times to give the effect of a very weak signal relative to the audio amplifier output with the audio gain control on maximum setting.

Testing. In checking over a receiver, certain troubles are often difficult to locate. By

making voltage or continuity tests, blown-out condensers, or burned-out resistors, coils or transformers may usually be located. Oscillators are usually checked by means of a d.c. voltmeter connected from ground to screen or plate-return circuits. Short-circuiting the tuning condenser plates usually should produce a change in voltmeter reading. A vacuum-tube-type voltmeter is very handy for the purpose of measuring the correct amount of oscillator r.f. voltage supplied to the first detector circuit. The proper value of the r.f. voltage is approximately one volt less than the fixed grid bias on the first detector when the voltage is introduced into either the grid or the cathode circuit.

Incorrect voltages, poor resistors or leaky by-pass or blocking condensers will ruin the audio tone of the receiver. Defective tubes can be checked in a tube tester. Loud-speaker rattle is not always a defect in the voice coil or spider support, or metallic filings in its air gap; more often the distortion is caused by overloading the audio amplifier. An i.f. amplifier can also impair splendid tone due to a defective tube or overloading.

It is a good idea to have all tubes in a receiver checked periodically, because if a tube

slowly becomes noisy, soft, or deficient in emission, the operator may not realize that the performance is not up to the full capabilities of the receiver. Any tube which does not test up to the equivalent of a new tube should be replaced, as a tube that once starts to "go" cannot possibly give very many more hours of useful service.

On the other hand, there is little point in replacing all tubes periodically, because tests have shown that a tube that has been in use for three or four years, if it still is giving satisfactory service, is just as likely to provide another year of uninterrupted service as is a brand new tube.

It should be borne in mind that electrolytic condensers, even of the best quality, have a limited life—the length of useful service depending upon the quality and application of the condenser. Unlike tubes, electrolytic condensers seldom give any trouble in the first three years of use (if of good quality and not overloaded). However, they seldom last more than five years, unless they are the less commonly used "wet" type. For this reason it is advisable to replace all electrolytic condensers every four years or so if reliability of service is important.

Radio Receiving Tube Characteristics

Footnote references for both standard and special receiving tubes will be found immediately following the socket connection diagrams for these tubes. Footnote references for various cathode ray tubes will be found immediately following the separate group of socket connections for cathode ray tubes.

A suffix (G) in parenthesis after a standard octal base tube indicates that the tube also is manufactured with glass envelope, a suffix (GT) indicating that the tube also is manufactured with small tubular glass envelope. Thus 6J5 (G) (GT) indicates that this tube is available with metal, glass, or small tubular glass envelope; 6AG7 indicates that this tube is available only in metal; and 5Y3-G indicates that this tube is available only in glass.

The "Bantam" line of GT type tubes by one manufacturer have a metal shell base which is connected to the pin which would ground the shell of an equivalent metal tube. A sleeve shield slipped over the tube thus is automatically grounded.

Several manufacturers supply certain of their tubes with ceramic base at a slight increase in the price. The ceramic base ordinarily is indicated by the presence of the letter "X" at the end of the regular type number.

Certain of the "7" series of tubes have a nominal heater rating of 7 volts instead of the usual 6.3 volt rating. The heater is the same, however, and either the "6" series or the "7" series may be used on either 6.3 or 7 volts. To simplify the tables, all such tubes are shown with a rating of 6.3 volts. The same applies to certain of the "14" series of tubes, these tubes having the same heater as corresponding tubes of the "12" series but a nominal heater rating of 14 volts instead of 12.6 volts.

Socket terminals shown as unused in the table of socket connections should not be used as tie-points for other wiring unless the tube has no corresponding pin, because "dead" pins are sometimes used as element supports.

When a "G" or "GT" octal base tube is used, the shell grounding terminal (usually pin no. 1) for the corresponding metal counterpart should be connected to ground the same as for a metal tube, as many "G" and "GT" types contain an internal shield.

Tube Base Connections

There are from four to eight pins on tube bases. With the exception of the five- and eight-prong types of bases the filament or heater pins are those which are heavier than the others.

With the exception of the octal (8-pin) base, the numbering system for the pins is as follows (viewing the tube or socket from the bottom, and with the two heavier heater (or filament) pins horizontal): the no. 1 pin is the left-hand heater or filament pin. Pins number 2, 3, and so forth follow around in a clockwise direction, the highest number being the right-hand cathode pin. Octal (8-pin) numbers start with no. 1 which is the first pin to the left of the key.

The letters F-F or H-H designate filament or heater, C or K for the cathode, P for the plate, etc., in socket connection or wiring diagrams. The grids of multi-grid tubes are numbered with respect to the position they occupy: no. 1 grid is closest to the cathode, no. 2 next closest, etc. When it is desirable that certain elements have a very low capacity with respect to other elements within the tube, they are sometimes terminated in a lead brought out to a cap on top of the tube.

TYPE	DESIGN	SOCKET CONN.	CATHODE TYPE AND RATING			USED AS	PLATE SUPPLY VOLTS	GRID BIAS VOLTS	SCREEN SUPPLY VOLTS	SCREEN CURRENT MILLAMP.	PLATE CURRENT MILLIAMPS	A.C. PLATE RESISTANCE OHMS	TRANSCONDUCTANCE (GRID-PLATE) UMHOS	AMPLIFICATION FACTOR	LOAD FOR STATED POWER OUTPUT OHMS	POWER OUTPUT WATTS
			C.T.	VOLTS	AMP											
00-A	DETECTOR TRIODE	4D	D.C. F	5.0	0.25	GRID-LEAK DETECTOR	45	GRID RETURN TO (-) FILAMENT		1.5	30000	666	20	—	—	
01-A	DETECTOR AMPLIFIER	4D	D.C. F	5.0	0.25	CLASS A AMPLIFIER	90 135	-4.5 -9.0	—	2.5 3.0	11000 10000	725 600	8.0 8.0	—	—	
0A4-G	GAS-TRIODE	4V	COLD	—	—	RELAY SERVICE	PEAK CATHODE CURRENT, 100 MAX. MA. D.C. CATHODE CURRENT, 25 MAX. MA. STARTER-ANODE DROP, 60 APPROX. VOLTS. ANODE DROP, 70 APPROX. VOLTS.									
OZ4 (G)	FULL WAVE GAS RECTIFIER	4R	COLD	—	—	RECTIFIER	STARTING-SUPPLY VOLTAGE PER PLATE, 300 MIN. PEAK VOLTS. PEAK PLATE CURRENT, 200 MAX. MA. D.C. OUTPUT CURRENT, 75 MAX., 30 MIN. MA. D.C. OUTPUT VOLTAGE, 300 MAX. VOLTS.									
1A4-P	SUPER-CONTROL R.F. AMPLIFIER PENTODE	4M	D.C. F	2.0	0.06	AMPLIFIER	FOR OTHER CHARACTERISTICS, REFER TO TYPE 1D5-GP									
1A4-T	SUPER-CONTROL R.F. AMPLIFIER TETRODE	4K	D.C. F	2.0	0.06	AMPLIFIER	135 160	-3.0 -3.0	67.5 67.5	0.7 0.7	2.2 2.2	350000 600000	625 650	—	—	
1A5-G	POWER AMPLIFIER PENTODE	8X	D.C. F	1.4	0.05	CLASS A AMPLIFIER	85 90	-4.5 -4.5	85 90	0.7 0.6	3.5 4.0	300000 300000	800 850	—	25000 25000	0.100 0.115
1A6 (S)	PENTAGRID CONVERTER	6L	D.C. F	2.0	0.06	CONVERTER	FOR OTHER CHARACTERISTICS, REFER TO TYPE 1D7-G.									
1A7-G (GT)	PENTAGRID CONVERTER	7Z	D.C. F	1.4	0.05	CONVERTER	90	0	45 (14)	0.6	0.55	600000	ANODE-GRID (#2): 90 MAX. VOLTS, 1.2 MA. OSCILLATOR-GRID (#1) RESISTOR, 0.2 MEG. CONVERSION TRANSCOND., 250 MICROMHOS.			
1B4-P	R.F. AMPLIFIER PENTODE	4M	D.C. F	2.0	0.06	AMPLIFIER	FOR OTHER CHARACTERISTICS, REFER TO TYPE 1E3-GP.									
1B5/25S	DUPLEX-DIODE TRIODE	6M	D.C. F	2.0	0.06	TRIODE UNIT AS AMPLIFIER	FOR OTHER CHARACTERISTICS, REFER TO TYPE 1H6-G.									
1B7-G	PENTAGRID CONVERTER	7Z	D.C. F	1.4	0.10	OSCILLATOR-AMPLIFIER CONVERTER	90	GRID RETURNS THRU 200000 Ω RESISTOR TO (-) F	45	1.3	1.5	350000	GRID #2, 90 VOLTS " " 1.6 MA.			
1B8-GT	MULTI-PURPOSE	6AW	D.C. F	1.4	0.10	DIODE-TRIODE BEAM AMPLIFIER	90 90	TRIODE, 0 BEAM AMP., -6	90	1.4	0.15 6.3	240000	275 1150	—	14000	210 MW.
1C5-G (GT)	POWER AMPLIFIER PENTODE	6X	D.C. F	1.4	0.10	CLASS A AMPLIFIER	83 90	-7.0 -7.5	83 90	1.6 1.6	7.0 115000	110000 1500	1500 1550	—	9000 8000	0.20 0.24
1C6	PENTAGRID CONVERTER	6L	D.C. F	2.0	0.12	CONVERTER	FOR OTHER CHARACTERISTICS, REFER TO TYPE 1C7-G.									
1C7-G	PENTAGRID CONVERTER	7Z	D.C. F	2.0	0.12	CONVERTER	125 160	-3.0 -3.0	87.5 87.5	2.5 2.0	1.3 1.5	600000 700000	ANODE GRID (#2): 180 MAX. VOLTS, 4.0 MA. OSCILLATOR-GRID (#1) RESISTOR, 1.6 MEG. CONVERSION TRANSCOND., 325 MICROMHOS. (18)			
1D5-GP (GT)	SUPER-CONTROL R.F. AMPLIFIER PENTODE	5Y	D.C. F	2.0	0.06	CLASS A AMPLIFIER	90 160	{ -3.0 MIN. }	87.5 87.5	0.9 0.8	2.2 2.3	600000 1000000	720 750	—	—	—
1D7-G	PENTAGRID CONVERTER	7Z	D.C. F	2.0	0.06	CONVERTER	135 160	{ -3.0 MIN. }	67.5 87.5	2.5 2.4	1.2 1.3	400000 500000	ANODE-GRID (#2): 180 MAX. VOLTS, 2.3 MA. OSCILLATOR-GRID (#1) RESISTOR, 1.6 MEG. CONVERSION TRANSCOND., 300 MICROMHOS. (19)			
1D8-GT	DIODE-TRIODE POWER AMPLIFIER PENTODE	6AJ	D.C. F	1.4	0.1	PENTODE UNIT AS CLASS A AMPLIFIER	45 90	-4.5 -9.0	45 90	0.3 1.0	1.6 5.0	300000 200000	850 925	—	—	
						TRIODE UNIT AS CLASS A AMPLIFIER	45 90	0 0	—	—	0.3 1.1	77000 43500	325 575	25 25	—	—
1E4-G	GENERAL PURPOSE TRIODE	5S	D.C. F	1.4	0.05	AMPLIFIER	90	-3.0	—	—	1.5	17000	625	14	—	—
1E5-GP	R.F. AMPLIFIER PENTODE	5Y	D.C. F	2.0	0.06	CLASS A AMPLIFIER	90 160	-3.0 -3.0	87.5 87.5	0.7 0.6	1.6 1.7	1000000 1500000	800 850	—	—	—
1E7-G	TWIN-PENTODE POWER AMPLIFIER	6C	D.C. F	2.0	0.24	CLASS A AMPLIFIER	135	-7.5	135	—	—	POWER OUTPUT IS FOR ONE TUBE AT STATED PLATE-TO-PLATE LOAD.		24000	0.575	

1F4	POWER AMPLIFIER PENTODE	5K	D.C. F	2.0	0.12	AMPLIFIER	FOR OTHER CHARACTERISTICS, REFER TO TYPE 1F5-G.									
1F5-G	POWER AMPLIFIER PENTODE	6X	D.C. F	2.0	0.12	CLASS A AMPLIFIER	90 135	-3.0 -4.5	90 135	1.1 2.4	4.0 8.0	240000 200000	1400 1700	20000 16000	0.11 0.31	
1F6	DUPLEX-DIODE PENTODE	8W	D.C. F	2.0	0.06	PENTODE UNIT AS AMPLIFIER	FOR OTHER CHARACTERISTICS, REFER TO TYPE 1F7-GV.									
1F7-G (GV)	DUPLEX-DIODE PENTODE	7AD	D.C. F	2.0	0.06	PENTODE UNIT AS R.F. AMPLIFIER	180	-1.5	67.5	0.7	2.2	1000000	650			
1G4-G (GT)	DETECTOR AMPLIFIER TRIODE	5S	D.C. F	1.4	0.05	CLASS A AMPLIFIER	90	-6.0			2.3	10700	625	6.8		
1G5-G	POWER AMPLIFIER PENTODE	6X	D.C. F	2.0	0.12	CLASS A AMPLIFIER	90 135	-6.0 -13.5	90 135	2.5 2.5	8.5 6.7	133000 180000	1500 1550	6500 9000	0.25 0.55	
1G6-G	TWIN-TRIODE AMPLIFIER	7AB	D.C. F	1.4	0.10	CLASS B AMPLIFIER	90	0			POWER OUTPUT IS FOR ONE TUBE AT STATED PLATE-TO-PLATE LOAD.			12000	0.675	
1H4-G	DETECTOR AMPLIFIER	5S	D.C. F	2.0	0.06	CLASS A AMPLIFIER	90 135 180	-4.5 -9.0 -13.5			2.5 3.0 3.1	11000 10300 10300	650 900 900	9.3 9.3 9.3		
1H5-G (GT)	DIODE HIGH-MU TRIODE	5Z	D.C. F	1.4	0.05	CLASS B AMPLIFIER	157.5	-15.0			1.0 ₁₅			8000	2.1 ₁₂	
1H6-G	DUPLEX-DIODE TRIODE	7AA	D.C. F	2.0	0.08	TRIODE UNIT AS CLASS A AMPLIFIER	90	0			0.15	240000	275	65		
1H6-G	DUPLEX-DIODE TRIODE	7AA	D.C. F	2.0	0.08	TRIODE UNIT AS CLASS A AMPLIFIER	135	-3.0			0.6	35000	575	20		
1J5-G	POWER AMPLIFIER PENTODE	6X	D.C. F	2.0	0.12	CLASS A AMPLIFIER	135	-16.5	135	1.8	7.0	125000	1000	125	13500	0.450
1J6-G	TWIN-TRIODE AMPLIFIER	7AB	D.C. F	2.0	0.24	CLASS B AMPLIFIER	135 135	0 -3.0			POWER OUTPUT IS FOR ONE TUBE AT STATED PLATE-TO-PLATE LOAD.			10000 10000	2.1 1.9	
1LA4	POWER AMPLIFIER PENTODE	5AD	D.C. F	1.4	0.05	CLASS A AMPLIFIER	90	-4.5	90	0.8	4.0	300000	650	255	25000	0.115
1LA6	PENTAGRID CONVERTER	7AK	D.C. F	1.4	0.05	CONVERTER	90	0	45	0.8	0.55	750000	250	OSC. GRID THRU 200000 Ω TO -F ANODE GRID 90 V., 1.2 MA.		
1LB4 (G)	POWER AMPLIFIER PENTODE	5AD	D.C. F	1.4	0.05	CLASS A AMPLIFIER	90	-9.0	90	1.0	5.0	200000	925	12000	0.20	
1LB6-GL	PENTAGRID CONVERTER	8AX	D.C. F	1.4	0.05	CONVERTER	90	0	67.5	2.2	0.4	2000000	100	ANODE GRID 87.5 V., 1.2 MA.		
1LE3-GL	TRIODE	4AA	FOR OTHER CHARACTERISTICS, REFER TO TYPE 1E4-G													
1LH4	DIODE HIGH-MU TRIODE	5AG	D.C. F	1.4	0.05	TRIODE UNIT AS CLASS A AMPLIFIER	90	0			0.15	240000	275	85		
1LN5	R.F. AMPLIFIER PENTODE	7AO	FOR OTHER CHARACTERISTICS, REFER TO TYPE 1N5-G													
1N5-C (GT)	R.F. AMPLIFIER PENTODE	5Y	D.C. F	1.4	0.05	CLASS A AMPLIFIER	90	0	90	0.3	1.2	1500000	750			
1N6-G (GT)	DIODE-POWER AMPLIFIER-PENTODE	7AM	D.C. F	1.4	0.05	PENTODE UNIT AS A.F. AMPLIFIER	90	-4.5	90	0.6	3.1	300000	600	25000	0.10	
1P5-G (GT)	R.F. AMPLIFIER PENTODE	5Y	D.C. F	1.4	0.05	CLASS A AMPLIFIER	90	0	90	0.7	2.3	600000	750	840		
1Q5-GT	BEAM POWER AMPLIFIER	6AF	D.C. F	1.4	0.10	CLASS A AMPLIFIER	90	-4.5	90	1.6	9.5		2100	8000	0.27	
1R5	PENTAGRID CONVERTER	7AT	D.C. F	1.4	0.05	CONVERTER	45 90	0 0	45 45	1.9 1.6	0.7 0.6	600000 750000	GRID #1 RESISTOR, 100 000 OHMS. CONVERSION TRANSCOND., 250 μMHOS			
1S4	POWER AMPLIFIER PENTODE	7AV	D.C. F	1.4	0.10	CLASS A AMPLIFIER	45	-4.5	45	0.8	3.6	250000	1250	6000	0.065	
1S5	DIODE-PENTODE	8AU	D.C. F	1.4	0.05	PENTODE UNIT AS CLASS A AMPLIFIER	PLATE SUPPLY, 41 VOLTS APPLIED THROUGH 1 MEGOHM RESISTOR. SCREEN SUPPLY, 41 VOLTS ₁₇ GRID BIAS, 0 VOLTS. GRID RESISTOR, 10 MEGOHMS. VOLTAGE GAIN, 30 APPROXIMATELY.									
1T4	SUPER-CONTROL R.F. AMPLIFIER PENTODE	6AR	D.C. F	1.4	0.05	CLASS A AMPLIFIER	45 90	0 0	45 45	0.7 0.65	1.9 2.0	350000 800000	700 750			
1T5-G (GT)	BEAM POWER AMPLIFIER	6X	D.C. F	1.4	0.05	CLASS A AMPLIFIER	90	-6.0	90	1.4	8.5		1150	14000	0.17	

TYPE	DESIGN	SOCKET	CATHODE TYPE AND RATING			USED AS	PLATE SUPPLY VOLTS	GRID BIAS ⁽²⁾ VOLTS	SCREEN SUPPLY VOLTS	SCREEN CURRENT MILLIAMPS	PLATE CURRENT MILLIAMPS	A.C. PLATE RESISTANCE OHMS	TRANSCONDUCTANCE (GRID-PLATE) JMHOS	AMPLIFICATION FACTOR	LOAD FOR STATED POWER OUTPUT OHMS	POWER OUTPUT WATTS
			G.T.	VOLTS	AMP.											
1-V	HALF-WAVE RECTIFIER	4G	H	6.3	0.3	WITH CONDENSER-INPUT FILTER	MAX. A.C. PLATE VOLTS (RMS) 325 MAX. D.C. OUTPUT MA., 45			MINIMUM TOTAL EFFECTIVE PLATE-SUPPLY IMPEDANCE: UP TO 117 VOLTS, 0 OHMS; AT 150 VOLTS, 30 OHMS; AT 325 VOLTS, 75 OHMS.						
2A3	POWER AMPLIFIER TRIODE	4D	F	2.5	2.5	CLASS A AMPLIFIER	250	-45.0	—	—	60.0	800	5250	4.2	2500	3.5
						PUSH-PULL CLASS AB ₁ AMPLIFIER	300	CATHODE BIAS, 780 OHMS ⁽¹³⁾ -62 VOLTS, FIXED BIAS			80.0 ⁽¹³⁾	—	—	—	5000	10.0 ⁽¹²⁾
2A3-H	POWER AMPLIFIER TRIODE		H	2.5	2.5	FOR OTHER CHARACTERISTICS, REFER TO TYPE 2A3.										
2A5	POWER AMPLIFIER PENTODE	6B	H	2.5	1.75	AMPLIFIER	FOR OTHER CHARACTERISTICS, REFER TO TYPE 6F6.									
2A6	DUPLEX-DIODE HIGH-MU TRIODE	6G	H	2.5	0.8	TRIODE UNIT AS AMPLIFIER	FOR OTHER CHARACTERISTICS, REFER TO TYPE 6SQ7.									
2A7(S)	PENTAGRID CONVERTER ⁽²⁾	7C	H	2.5	0.8	CONVERTER	FOR OTHER CHARACTERISTICS, REFER TO TYPE 6A8.									
2B7	DUPLEX-DIODE PENTODE	7D	H	2.5	0.8	PENTODE UNIT AS AMPLIFIER	FOR OTHER CHARACTERISTICS REFER TO TYPE 6BB.									
2E5	ELECTRON-RAY TUBE	8R	H	2.5	0.8	TUNING INDICATOR	FOR OTHER CHARACTERISTICS REFER TO TYPE 6E5.									
2W3 (GT)	HALF-WAVE RECTIFIER	4Y	F	2.5	1.5	MAXIMUM A.C. VOLTAGE 350 VOLTS, RMS MAXIMUM D.C. OUTPUT CURRENT 55 MILLIAMPERES										
2Y2	HALF-WAVE RECTIFIER	4AB	H	2.5	1.75	MAXIMUM A.C. VOLTAGE 4500 VOLTS, RMS MAXIMUM D.C. OUTPUT CURRENT 5.0 MILLIAMPERES										
3A8 (GT)	DIODE-TRIODE R.F. PENTODE	8AS	D.C. F	1.4	0.1	TRIODE UNIT AS CLASS A AMPLIFIER	90	0	—	—	0.3	240000	275	65	—	—
				2.8	0.05	PENTODE UNIT AS CLASS A AMPLIFIER	90	0	90	0.3	1.2	600000	750	—	—	—
3C5-GT	POWER AMPLIFIER PENTODE	7AD	D.C. F	1.4 2.8	0.10 0.05	POWER AMPLIFIER PENTODE	9D	-9.0	—	—	6.0	—	1450	—	10000	0.26
3Q5-GT	BEAM POWER AMPLIFIER	7AQ	D.C. F	1.4	0.10	CLASS A AMPLIFIER	9D	-4.5	9D	1.8	9.5	100000	2100	—	8000	0.27
				2.8	0.05		9D	-4.3	9D	1.0	7.5	110000	1800	8000	0.25	
4A6-G	TWIN-TRIODE POWER AMPLIFIER	6L	D.C. F	4.0	0.08	CLASS B AMPLIFIER	90	-2.0	ZERO-SIGNAL PLATE CURRENT, 1.8 MA. MAX. -SIGNAL PLATE CURRENT, 21.0 MA.				8000	1.0		
5T4	FULL-WAVE RECTIFIER	5T	F	5.0	2.0	WITH CONDENSER INPUT FILTER	MAX. A.C. VOLTS PER PLATE (RMS), 450 MAX. PEAK INVERSE VOLTS, 1550			MAX. D.C. OUTPUT MA., 225 MAX. PEAK PLATE MA., 675			MIN. TOTAL EFFECTIVE SUPPLY IMPEDANCE PER PLATE, 150 OHMS			
						WITH CHOKE INPUT FILTER	MAX. A.C. VOLTS PER PLATE (RMS), 550 MAX. PEAK INVERSE VOLTS, 1550			MAX. D.C. OUTPUT MA., 225 MAX. PEAK PLATE MA., 675			MINIMUM VALUE OF INPUT CHOKE, 3 HENRIES			
5U4-G	FULL-WAVE RECTIFIER	5T	F	5.0	3.0	WITH CONDENSER INPUT FILTER	MAX. A.C. VOLTS PER PLATE (RMS), 450 MAX. PEAK INVERSE VOLTS, 1550			MAX. D.C. OUTPUT MA., 225 MAX. PEAK PLATE MA., 675			MIN. TOTAL EFFECTIVE SUPPLY IMPEDANCE PER PLATE, 75 OHMS			
						WITH CHOKE INPUT FILTER	MAX. A.C. VOLTS PER PLATE (RMS), 550 MAX. PEAK INVERSE VOLTS, 1550			MAX. D.C. OUTPUT MA., 225 MAX. PEAK PLATE MA., 675			MINIMUM VALUE OF INPUT CHOKE, 3 HENRIES			
5V4-G	FULL-WAVE RECTIFIER	5L	H	5.0	2.0	WITH CONDENSER INPUT FILTER	MAX. A.C. VOLTS PER PLATE (RMS), 375 MAX. PEAK INVERSE VOLTS, 1400			MAX. D.C. OUTPUT MA., 175 MAX. PEAK PLATE MA., 525			MIN. TOTAL EFFECTIVE SUPPLY IMPEDANCE PER PLATE, 85 OHMS			
						WITH CHOKE INPUT FILTER	MAX. A.C. VOLTS PER PLATE (RMS), 500 MAX. PEAK INVERSE VOLTS, 1400			MAX. D.C. OUTPUT MA., 175 MAX. PEAK PLATE MA., 525			MINIMUM VALUE OF INPUT CHOKE, 4 HENRIES			

5W4	FULL-WAVE RECTIFIER	5T	F	5.0	1.5	WITH CONDENSER- INPUT FILTER	MAX. A.C. VOLTS PER PLATE (RMS), 350 MAX. PEAK INVERSE VOLTS, 1400			MAX. D.C. OUTPUT MA., 100 MAX. PEAK PLATE MA., 300			MIN. TOTAL EFFECTIVE SUPPLY IMPEDANCE PER PLATE, 25 OHMS			
						WITH CHOKE INPUT FILTER	MAX. A.C. VOLTS PER PLATE (RMS), 500 MAX. INVERSE PEAK VOLTS, 1400			MAX. D.C. OUTPUT MA., 100 MAX. PEAK PLATE MA., 300			MINIMUM VALUE OF INPUT CHOKE, 6 HENRIES			
5X3	FULL-WAVE RECTIFIER	4C	F	5.0	2.0	RECTIFIER	MAX. A.C. VOLTS PER PLATE (RMS), 400 MAX. D.C. OUTPUT MA., 110									
5X4-G	FULL-WAVE RECTIFIER	5Q	F	5.0	3.0	FOR OTHER RATINGS, REFER TO TYPE 5U4-G										
5Y3-G	FULL-WAVE RECTIFIER	5T	F	5.0	2.0	WITH CONDENSER- INPUT FILTER	MAX. A.C. VOLTS PER PLATE (RMS), 350 MAX. PEAK INVERSE VOLTS, 1400			MAX. D.C. OUTPUT MA., 125 MAX. PEAK PLATE MA., 375			MIN. TOTAL EFFECTIVE SUPPLY IMPEDANCE PER PLATE, 10 OHMS			
						WITH CHOKE INPUT FILTER	MAX. A.C. VOLTS PER PLATE (RMS), 500 MAX. PEAK INVERSE VOLTS, 1400			MAX. D.C. OUTPUT MA., 125 MAX. PEAK PLATE MA., 375			MINIMUM VALUE OF INPUT CHOKE, 5 HENRIES			
5Y4-G	FULL-WAVE RECTIFIER	5Q	F	5.0	2.0	FOR OTHER RATINGS, REFER TO TYPE 5Y3-G										
5Z3	FULL-WAVE RECTIFIER	4C	F	5.0	3.0	FOR OTHER RATINGS, REFER TO TYPE 5U4-G										
5Z4	FULL-WAVE RECTIFIER	5L	H	5.0	2.0	WITH CONDENSER- INPUT FILTER	MAX. A.C. VOLTS PER PLATE (RMS), 350 MAX. PEAK INVERSE VOLTS, 1400			MAX. D.C. OUTPUT MA., 125 MAX. PEAK PLATE MA., 375			MIN. TOTAL EFFECTIVE SUPPLY IMPEDANCE PER PLATE, 30 OHMS			
						WITH CHOKE- INPUT FILTER	MAX. A.C. VOLTS PER PLATE (RMS), 500 MAX. PEAK INVERSE VOLTS, 1400			MAX. D.C. OUTPUT MA., 125 MAX. PEAK PLATE MA., 375			MINIMUM VALUE OF INPUT CHOKE, 5 HENRIES			
6A3	POWER AMPLIFIER TRIODE	4D	F	6.3	1.0	POWER AMPLIFIER TRIODE	FOR OTHER CHARACTERISTICS, REFER TO TYPE 2A3									
6A4/LA	POWER AMPLIFIER PENTODE	5B	F	6.3	0.3	CLASS A AMPLIFIER	100 180	-8.5 -12.0	100 180	1.6 3.9	9.0 22.0	63250 45500	1200 2200	— —	11000 8000	0.31 1.40
6A5-G	POWER AMPLIFIER TRIODE	6T	H	6.3	1.25	POWER OUTPUT AMPLIFIER	325	-58.0 FIXED BIAS SELF BIAS	—	—	40.0	800	5250	4.2	2500 PP 3000 PP 5000	1TUBE 3.75
6A6	TWIN-TRIODE AMPLIFIER	7B	H	6.3	0.6	AMPLIFIER	FOR OTHER CHARACTERISTICS, REFER TO TYPE 6N7-G.									
6A7	PENTAGRID CONVERTER [Ⓢ]	7C	H	6.3	0.3	CONVERTER	FOR OTHER CHARACTERISTICS, REFER TO TYPE 8A8									
6AB(G)GT	PENTAGRID CONVERTER [Ⓢ]	8A	H	6.3	0.3	CONVERTER	100 250	-1.5 -3.0	50 100	1.3 2.7	1.1 3.5	600000 360000	ANODE-GRID (#2): 250 [Ⓢ] MAX. VOLTS, 4.0 MA. OSCILLATOR-GRID (#1) RESISTOR CONVERSION TRANSCOND., 550 μ MHOS [Ⓢ]			
6AB5/6N5	ELECTRON-RAY TUBE	6R	H	6.3	0.15	VISUAL INDICATOR	PLATE & TARGET SUPPLY = 135 VOLTS. TRIODE PLATE RESISTOR = 0.25 MEG. TARGET CURRENT = 2.0 MA. GRID BIAS, -10.0 VOLTS; SHADOW ANGLE, 0°; BIAS, 0 VOLTS; ANGLE, 90°; PLATE CURRENT, 0.5 MA.									
6AB7/1853	TELEVISION AMPLIFIER PENTODE	8N	H	6.3	0.45	CLASS A AMPLIFIER	300	-3.0	200	3.2	12.5	700000	5000	—	—	—
						CLASS B AMPLIFIER	250	0	—	—	5.0 [Ⓢ]	—	—	—	—	10000
6AC5-G(GT)	HIGH-MU POWER AMPLIFIER TRIODE	6Q	H	6.3	0.4	DYNAMIC COUPLED AMPLIFIER WITH TYPE 6P5-G DRIVER	250	BIAS FOR BOTH 6AC5-G AND 6P5-G IS DEVELOPED IN COUPLING CIRCUIT, AVERAGE PLATE CURRENT OF DRIVER = 5.5 MILLIAMPERES AVERAGE PLATE CURRENT OF 6AC5-G = 32 MILLIAMPERES					7000	3.7	—	—
6AC6-G(GT)	TRIPLE-TWIN POWER AMPLIFIER	7W	H	6.3	1.1	POWER AMPLIFIER	160	0	—	—	OUTPUT 45 INPUT 7	18000	3000	54	3500	3.6
6AC7/1852	TELEVISION AMPLIFIER PENTODE	6N	H	6.3	0.45	CLASS A AMPLIFIER	300	CATHODE BIAS	150	2.5	10.0	750000	9000	CATHODE-BIAS RESISTOR, 160 OHMS		
6AD5-G	HIGH-MU TRIODE	8Q	H	6.3	0.3	HIGH-MU TRIODE AMPLIFIER	250	-2.0	—	—	0.9	66000	—	100	—	—
6AD6-G	ELECTRON-RAY TUBE	7AG	H	6.3	0.15	VISUAL INDICATOR	TARGET VOLTAGE 150-100	RAY CONTROL VOLTAGE 0 TO -50								

TYPE	DESIGN	SOCKET CONN.	CATHODE TYPE AND RATING			USED AS	PLATE SUPPLY VOLTS	GRID BIAS ^② VOLTS	SCREEN SUPPLY VOLTS	SCREEN CURRENT MILLIAMP.	PLATE CURRENT MILLIAMP.	A.C. PLATE RESISTANCE OHMS	TRANS- CONDUCTANCE (GRID-PLATE) μ MHOS	AMPLI- FICATION FACTOR	LOAD FOR STATED POWER OUTPUT OHMS	POWER OUTPUT WATTS			
			C.T.	VOLTS	AMP.														
6AD7-G	TRIODE A.F. POWER PENTODE	8AY	H	6.3	0.85	TRIODE UNIT AS CLASS A AMPLIFIER	250	-25.0	—	—	4.0	19000	325	6.0	—	—			
						PENTODE UNIT AS CLASS A AMPLIFIER	PENTODE UNIT IS IDENTICAL WITH TYPE 6F6-G. 6F6-G AND 6AD7-G MAY BE USED TOGETHER AS COMBINED PHASE INVERTER AND PUSH-PULL POWER AMPLIFIER												
6AE5-GT	AMPLIFIER TRIODE	6Q	H	6.3	0.3	CLASS A AMPLIFIER	95	-15.0	—	—	7.0	3500	1200	4.2	—	—			
6AE6-G	TWIN-PLATE CONTROL-TUBE	7AH	H	6.3	0.15	SHARP-CUTOFF TRIODE	250 250	-1.5 -9.5	—	—	4.5 0.01	35000	950	33.0	CONTROL TUBE FOR TWIN-ELECTRON-RAY INDICATOR TUBES, SUCH AS 6AF6-G				
						REMOTE CUTOFF TRIODE	250 250	-1.5 -35.0	—	—	6.5 0.01	25000	1000	25.0	—	—			
6AF5-G (GT)	AMPLIFIER TRIODE	8Q	H	6.3	0.3	CLASS A AMPLIFIER	180	-16.0	—	—	7.0	4900	1500	7.4	—	—			
6AF6-G	ELEC.-RAY TUBE TWIN-INDI.-TYPE	7AG	H	6.3	0.15	VISUAL INDICATOR	TARGET VOLTAGE, 100 VOLTS. CONTROL ELECTRODE VOLTAGE, 0 VOLTS; SHADOW ANGLE, 100°; TARGET CURRENT 0.9 MA., CONTROL-ELECTRODE VOLTAGE, 60 VOLTS; ANGLE, 0°.												
							TARGET VOLTAGE, 135 VOLTS. CONTROL ELECTRODE VOLTAGE, 0 VOLTS; SHADOW ANGLE, 100°; TARGET CURRENT, 1.5 MA. CONTROL-ELECTRODE VOLTAGE, 61 VOLTS; ANGLE, 0°												
6AF7-G	ELEC.-RAY TUBE TWIN-INDI. TYPE	8AG	H	6.3	0.3	VISUAL INDICATOR													
6AG7	VIDEO POWER AMPLIFIER PENTODE	6Y	H	6.3	0.65	CLASS A AMPLIFIER	250	-2.0	140	6.5	33.0	LOAD RESISTANCE, 1700 OHMS. PEAK-TO-PEAK VOLTS OUTPUT, 70 APPROX.							
6AL6-G	BEAM POWER AMPLIFIER	8AM	H	6.3	0.9	CLASS A AMPLIFIER	250	-14.0	250	5.0	72.0	—	6000	—	2500	6.5			
6B4-G	POWER AMPLIFIER TRIODE	5S	F	6.3	1.0	CLASS A AMPLIFIER	250	-45.0	—	—	60.0	600	5250	4.2	2500	3.2			
6B5	DIRECT-COUPLED POWER AMPLIFIER	6AS	H	6.3	0.8	CLASS A AMPLIFIER	FOR OTHER CHARACTERISTICS, REFER TO TYPE 6N6-G.												
6B6-G	DUPLEX-DIODE HIGH-MU TRIODE	7V	H	6.3	0.3	TRIODE UNIT AS AMPLIFIER	FOR OTHER CHARACTERISTICS, REFER TO TYPE 6SQ7.												
6B7	DUPLEX-DIODE PENTODE	7D	H	6.3	0.3	PENTODE UNIT AS AMPLIFIER	FOR OTHER CHARACTERISTICS, REFER TO TYPE 6B8-G.												
6B8(G)	DUPLEX-DIODE PENTODE	8E	H	6.3	0.3	PENTODE UNIT AS R.F. AMPLIFIER	100 250	-3.0 -3.0	100 125	1.7 2.3	5.8 9.0	300 000 600 000	950 1125	—	—	—			
						PENTODE UNIT AS A.F. AMPLIFIER	90 300 300	—	—	—	—	—	—	—	—	—	—	—	—
6C5(G)(GT)	DETECTOR, AMPLIFIER TRIODE	6Q	H	6.3	0.3	CLASS A AMPLIFIER	250	-8.0	—	—	6.0	10000	2000	20	—	—			
						BIAS DETECTOR	250	—	—	—	—	—	—	—	—	—	—	—	—
						CATHODE BIAS, 6400 OHMS } GRID RESISTOR, ⑩ 0.25 MEGOHM. { GAIN PER STAGE=11 CATHODE BIAS, 5300 OHMS } GRID RESISTOR, ⑩ 0.25 MEGOHM. { GAIN PER STAGE=13													
6C6	TRIPLE-GRID DETECTOR AMPLIFIER	6F	H	6.3	0.3	AMPLIFIER DETECTOR	FOR OTHER CHARACTERISTICS, REFER TO TYPE 6J7.												
6C8-G	TWIN-TRIODE AMPLIFIER	8G	H	6.3	0.3	EACH UNIT AS AMPLIFIER	250	-4.5	—	—	3.2	22500	1600	36	—	—			

Tube Type	Symbol	Frequency	Grid	Beam	Control	Function	FOR OTHER CHARACTERISTICS, REFER TO TYPE 6U7-G.									
6D6	TRIPLE-GRID SUPER CONTROL AMPLIFIER	6F	H	6.3	0.3	AMPLIFIER MIXER	FOR OTHER CHARACTERISTICS, REFER TO TYPE 6U7-G.									
6D8-G	PENTAGRID CONVERTER	8A	H	6.3	0.15	CONVERTER	135 250	-3.0 -3.0	67.5 100	—	—	600000 400000	ANODE-GRID (#2): 250 ⁽³⁾ MAX. VOLTS, 4.3 MA. OSCILLATOR-GRID (#1) RESISTOR ⁽¹⁹⁾ CONVERSION TRANSCONDUCTANCE, 550 μMHOS			
6E5	ELECTRON-RAY TUBE	6R	H	6.3	0.3	VISUAL INDICATOR	PLATE & TARGET SUPPLY= 100 VOLTS, TRIODE PLATE RESISTOR= 0.5 MEG. TARGET CURRENT= 1.0 MA. GRID BIAS, -3.3 VOLTS; SHADOW ANGLE, 0°. BIAS, 0 VOLTS; ANGLE, 90°; PLATE CURRENT, 0.19 MA. PLATE & TARGET SUPPLY= 250 VOLTS, TRIODE PLATE RESISTOR= 1.0 MEG. TARGET CURRENT= 4.0 MA. GRID BIAS, -8.0 VOLTS; SHADOW ANGLE, 0°. BIAS, 0 VOLTS; ANGLE, 90°; PLATE CURRENT, 0.24 MA.									
6E6	TWIN TRIODE	7B	H	6.3	0.6	PUSH-PULL CLASS A AMPLIFIER	180 250	-20.0 -27.5	—	—	11.5 18.0	4300 3500	1400 1700	8 6	15000 14000	0.75 1.6
6F5 (G) (GT)	HIGH-MU TRIODE	5M	H	6.3	0.3	AMPLIFIER	FOR OTHER CHARACTERISTICS, REFER TO TYPE 6SF5									
6F6 (G) (GT)	POWER AMPLIFIER PENTODE	7S	H	6.3	0.7	PENTODE CLASS A AMPLIFIER	250 285	-18.5 -20.0	250 285	6.5 7.0	34.0 36.0	80000 78000	2500 2550	—	7000 7000	3.2 4.8
						TRIODE ⁽²⁾ CLASS A AMPLIFIER	250	-20.0	—	—	31.0	2600	2600	6.8	4000	0.85
						PENTODE PUSH-PULL CLASS A AMPLIFIER	315 315	CATH. BIAS -24.0	285 285	12.0 12.0 ⁽¹³⁾	62.0 ⁽¹³⁾ 62.0 ⁽¹³⁾	CATH. BIAS RESISTOR, 320 OHMS ⁽¹³⁾		10000 10000	10.5 11.0 ⁽¹²⁾	
						PENTODE PUSH-PULL CLASS AB ₂ AMPLIFIER	375 375	CATH. BIAS -28.0	250 250	8.0 ⁽¹³⁾ 5.0 ⁽¹³⁾	54.0 ⁽¹³⁾ 34.0 ⁽¹³⁾	CATHODE BIAS RESISTOR, 340 OHMS ⁽¹³⁾		10000 10000	19.0 18.5 ⁽¹²⁾	
						TRIODE PUSH-PULL ⁽²⁾ CLASS AB ₂ AMPLIFIER	350 350	CATH. BIAS -38.0	—	—	50.0 ⁽¹³⁾ 48.0 ⁽¹³⁾	CATHODE BIAS RESISTOR, 730 OHMS ⁽¹³⁾		10000 8000	9.0 ⁽¹²⁾ 13.0 ⁽¹²⁾	
6F7	TRIODE PENTODE	7E	H	6.3	0.3	TRIODE UNIT AS CLASS A AMPLIFIER	100	{-3.0 MIN.}	—	—	3.5	18000	500	6.0	—	—
						PENTODE UNIT AS CLASS A AMPLIFIER	100 250	{-3.0 MIN.}	100 100	1.6 1.5	6.3 6.5	290000 850000	1050 1100	—	—	—
						PENTODE UNIT AS MIXER	250	-10.0	100	0.8	2.8	OSCILLATOR PEAK VOLTS= 7.0 CONVERSION TRANSCONDUCTANCE= 30 MICROMHOS				—
6F8-G	TWIN TRIODE AMPLIFIER	8G	H	8.3	0.6	EACH UNIT AS AMPLIFIER	90 250	0 -8.0	—	—	10.0 9.0	8700 7700	3000 2800	20 20	—	—
6G5/6U5	ELECTRON-RAY TUBE	REFER TO 6U5 DATA														
6G6-G	POWER AMPLIFIER PENTODE	7S	H	6.3	0.15	PENTODE CLASS A AMPLIFIER	135 180	-8.0 -9.0	135 180	2.0 2.5	11.5 15.0	170000 175000	2100 2300	—	12000 10000	0.8 1.1
						TRIODE ⁽²⁾ CLASS A AMPLIFIER	180	-12.0	—	—	11.0	4750	2000	9.5	12000	0.25
6H4-GT	DIODE	5AF	H	6.3	0.15	DETECTOR RECTIFIER	100	—	—	—	4.0	—	—	—	—	
6H6 (G) (GT)	TWIN DIODE	7Q	H	6.3	0.3	DETECTOR RECTIFIER	MAXIMUM A.C. VOLTAGE PER PLATE 117 VOLTS, RMS MAXIMUM D.C. OUTPUT CURRENT 4 MILLIAMPERES									
6H8-G	DUPLEX-DIODE PENTODE	8E	H	8.3	0.3	PENTODE UNIT AS AMPLIFIER	250	-2.0	—	—	8.5	650000	2400	—	—	—
6J5 (G) (GT)	DETECTOR-AMPLIFIER-TRIODE	6Q	H	6.3	0.3	CLASS A AMPLIFIER	90 250	0 -8.0	—	—	10.0 9.0	8700 7700	3000 2800	20 20	—	—
6J7 (G) (GT)	TRIPLE-GRID DETECTOR AMPLIFIER	7R	H	6.3	0.3	PENTODE CLASS A R.F. AMPLIFIER	100 250	-3.0 -3.0	100 100	0.5 0.3	2.0 2.0	1000000 1000000+	1185 1225	—	—	—
						PENTODE CLASS A A.F. AMPLIFIER	90 ⁽¹⁸⁾ 300 ⁽¹⁸⁾	CATHODE BIAS, 2800 OHMS. SCREEN RESISTOR=1.2 MEG. GRID RESISTOR ⁽¹⁶⁾ [GAIN PER STAGE= 85 0.5 MEGOHM	—	—	—	—	—	—	—	—
						PENTODE BIAS DETECTOR	250	-4.3	100	CATHODE CURRENT 0.43 MA.		—	PLATE RESISTOR, 500000 OHMS GRID RESISTOR ⁽¹⁶⁾ 250000 OHMS		—	—
						TRIODE ⁽¹⁹⁾ CLASS A AMPLIFIER	180 250	-5.3 -8.0	—	—	5.3 6.5	11000 10500	1800 1900	20 20	—	—

TYPE	DESIGN	SOCKET CONN.	CATHODE TYPE AND RATING			USED AS	PLATE SUPPLY VOLTS	GRID BIAS VOLTS ②	SCREEN SUPPLY VOLTS	SCREEN CURRENT MILLIAMPS.	PLATE CURRENT MILLIAMPS.	A.C. PLATE RESISTANCE OHMS	TRANSDUCTANCE (GRID-PLATE) μMHMS	AMPLIFICATION FACTOR	LOAD FOR STATED POWER OUTPUT OHMS	POWER OUTPUT WATTS				
			C.T.	VOLTS	AMP.															
6J8-G	TRIODE-HEPTODE	6H	H	6.3	0.3	TRIODE SECTION AS OSCILLATOR	100 250	50000 Ω 50000 Ω	—	—	3.0 5.0	8750 1600	14	PLATE VOLTAGE APPLIED THROUGH 20000 OHM RESISTOR	—	—				
						HEPTODE SECTION AS MIXER	100 250	-3.0 -3.0	100 100	3.0 2.9	1.4 1.3	900000 4000000	250 290							
6K5-G (GT)	HIGH-MU TRIODE	5U	H	6.3	0.3	CLASS A AMPLIFIER	100 250	-1.5 -3.0	—	—	0.35 1.1	76000 50000	900 1400	70 70	—	—				
6K6-G (GT)	POWER AMPLIFIER PENTODE	7S	H	6.3	0.4	CLASS A AMPLIFIER	100	-7.0	100	1.6	9.0	104000	1500	—	12000	0.35				
							180	-13.5	180	3.0	18.5	81000	1850							
							250	-18.0	250	5.5	32.0	66000	2200							
							315	-21.0	250	4.0	25.5	75000	2100				9000	4.50		
6K7 (G)(GT)	TRIPLE-GRID SUPER-CONTROL AMPLIFIER	7R	H	6.3	0.3	CLASS A AMPLIFIER	90 250	-3.0 -3.0	90 125	1.3 2.8	5.4 10.5	300000 800000	1275 1650	—	—					
						MIXER IN SUPERHETERODYNE	250	-10.0	100	OSCILLATOR PEAK VOLTS = 7.0				—	—					
6K8(G)(GT)	TRIODE-HEXODE CONVERTOR	8K	H	6.3	0.3	TRIODE UNIT AS OSCILLATOR	100	TRIODE-GRID RESISTOR 50000 Ω			3.8	TRIODE-GRID & HEXODE-GRID CURRENT = 0.15 MA.								
						HEXODE UNIT AS MIXER	100 250	-3.0 -3.0	100 100	6.2 6.0	2.3 2.5	400000 800000	CONVERSION TRANSCOND., 325 μMHMS. CONVERSION TRANSCOND., 350 μMHMS.							
6L5-G	DETECTOR AMPLIFIER TRIODE	6Q	H	6.3	0.15	CLASS A AMPLIFIER	135 250	-5.0 -9.0	—	—	3.5 8.0	11300 9000	1500 1900	17 17	—	—				
6L6 (G)	BEAM POWER AMPLIFIER	7AC	H	6.3	0.9	SINGLE-TUBE CLASS A AMPLIFIER	250 250	-14.0 CATH. BIAS	250 250	5.0 5.4	72.0 75.0	CATHODE BIAS RESISTOR, 170 OHMS.				2500 2500	6.5 6.5			
						PUSH-PULL CLASS A AMPLIFIER	270 270	-17.5 CATH. BIAS	270 270	11.0 ⑬ 11.0 ⑬	134.0 ⑬ 134.0 ⑬	CATHODE BIAS RESISTOR 125 OHMS. ⑬				5000 5000	17.5 ⑬ 18.5 ⑬			
						PUSH-PULL CLASS AB ₁ AMPLIFIER	360 360	-22.5 CATH. BIAS	270 270	5.0 ⑬ 5.0 ⑬	88.0 ⑬ 88.0 ⑬	CATHODE BIAS RESISTOR, 250 OHMS ⑬				6600 9000	26.5 ⑬ 24.5 ⑬			
						PUSH-PULL CLASS AB ₂ AMPLIFIER	360 360	-18.0 -22.5	225 270	3.5 ⑬ 5.0 ⑬	78.0 ⑬ 68.0 ⑬	—				6000 3600	31.0 ⑬ 47.0 ⑬			
						SINGLE TRIODE ⑳	250 250	-20.0 CATH. BIAS	—	—	40.0 40.0	1700 4700 6.0				5000 8000	1.4 1.3			
						CATHODE BIAS RESISTOR, 490 OHMS														
						OSCILLATOR-GRID (#3) BIAS, -10 VOLTS. GRID #3 PEAK SWING, 12 VOLTS MINIMUM. CONVERSION TRANSCOND., 375 MICROMHMS														
						CLASS A AMPLIFIER														
6L7(G)	PENTAGRID MIXER AMPLIFIER ㉑	7T	H	6.3	0.3	MIXER IN SUPERHETERODYNE	250	-3.0	100	7.1	2.4	800000	1100	—	—					
6M6-G	POWER AMPLIFIER PENTODE	7S	H	6.3	1.2	CLASS A AMPLIFIER	250	-6.0	250	4.0	36.0	—	9500	—	7000	4.40				
6M7-G	R.F. AMPLIFIER PENTODE	7R	H	6.3	0.3	AMPLIFIER	250	-2.5	125	2.8	10.5	900000	3400	—	—					
6M8-GT	DIODE-TRIODE PENTODE	8AU	H	6.3	0.6	TRIODE UNIT AS A.F. AMPLIFIER	100	-1.0	—	—	0.5	91000	1100	—	—					
						PENTODE UNIT AS R.F. AMPLIFIER	100	-3.0	—	—	6.5	200000	1900	—	—					
6N5	ELECTRON-RAY TUBE	6R	H	6.3	1.15	VISUAL INDICATOR	SUPERSEDED BY TYPE 6AB5/6N5									—	—			

6N6-G	DIRECT-COUPLED POWER AMPLIFIER	7AU	H	8.3	0.8	CLASS A AMPLIFIER	OUTPUT TRIODE: PLATE VOLTS, 300; PLATE MA., 42; LOAD, 7000 OHMS. INPUT TRIODE: PLATE VOLTS, 300; GRID VOLTS, 0; A.F. SIGNAL VOLTS (RMS), 15; PLATE MA., 9.0								4.0	
6N7(G)	TWIN-TRIODE AMPLIFIER	8B	H	6.3	0.6	CLASS A AMPLIFIER (AS DRIVER) ①	250	-5.0	—	—	6.0	11300	3100	35	20000	EXCEEDS
						294	-6.0	—	—	7.0	11000	3200	35	OR MORE	0.4	
6P5-G (GT)	DETECTOR AMPLIFIER TRIODE	6Q	H	6.3	0.3	CLASS A AMPLIFIER	100	-5.0	—	—	2.5	12000	1150	13.8	—	—
						250	-13.5	—	—	5.0	9500	1450	13.8	—	—	
6P7-G	TRIODE PENTODE	7U	H	6.3	0.3	TRIODE UNIT AS OSCILLATOR	100	-3.0	—	—	2.4	16200	525	8.5	D.C. GRID CURRENT = 0.15 MILLIAMPERE	
						PENTODE UNIT AS MIXER	250	-10.0	100	0.8	2.8	2000000	CONVERSION TRANSCOND., 300 μ MHOS OSCILLATOR PEAK VOLTS = 7.0			
6P8-G	TRIODE HEXODE	8K	H	6.3	0.8	TRIODE UNIT AS OSCILLATOR	100	TRIODE-GRID RESISTOR = 50000 Ω			2.2	—	—	—	—	—
						PENTODE UNIT AS MIXER	250	-2.4	75 ②	1.4	1.5	—	650	—	—	—
6Q7(G)(GT)	DUPLEX-DIODE HIGH-MU TRIODE	7V	H	6.3	0.3	TRIODE UNIT AS CLASS A AMPLIFIER	100	-1.5	—	—	0.35	87500	800	70	—	—
						250	-3.0	—	—	1.1	58000	1200	70	—	—	
6R6-G	REMOTE CUTOFF R.F. PENTODE	8AA	H	6.3	0.3	CLASS A AMPLIFIER	250	-3.0	100	1.7	7.0	800000	1450	—	—	—
						250	-9.0	—	—	9.5	6500	1900	18	—	—	
6R7(G) (GT)	DUPLEX-DIODE TRIODE	7V	H	6.3	0.3	TRIODE UNIT AS CLASS A AMPLIFIER	90 ⑦	CATHODE BIAS, 4400 OHMS.			GRID RESISTOR, ⑩ 0.25 MEGOHM	GAIN PER STAGE = 10				
6S6-GT	REMOTE CUTOFF R.F. PENTODE	5AK	H	6.3	0.45	CLASS A AMPLIFIER	250	-2.0	100	3.0	13.0	350000	4000	—	—	—
						250	-3.0	—	—	8.5	1000000	1250	1750	—	—	
6S7(G)	TRIPLE-GRID AMPLIFIER	7R	H	8.3	0.15	CLASS A AMPLIFIER	135	-3.0	67.5	0.9	3.7	1000000	1250	—	—	—
6SA7(GT)	PENTAGRID CONVERTER ②	8R	H	8.3	0.3	CONVERTER	100	—	100	8.0	3.2	500000	GRID #1 RESISTOR, 20000 OHMS.			
						250	—	100	8.0	3.4	800000	CONVERSION TRANSCOND., 450 μ MHOS				
6SC7	TWIN-TRIODE AMPLIFIER	8S	H	8.3	0.3	EACH UNIT AS AMPLIFIER	250	-2.0	—	—	2.0	53000	1325	70	—	—
6SD7-GT	R.F. AMPLIFIER PENTODE	8N	H	6.3	0.3	CLASS A AMPLIFIER	250	-2.0	100	1.9	6.0	1000000	3600	—	—	—
6SE7-GT	R.F. AMPLIFIER PENTODE	8N	H	6.3	0.3	CLASS A AMPLIFIER	250	-1.5	100	1.5	4.5	1100000	3400	—	—	—
6SF5(GT)	HIGH-MU TRIODE	6AB	H	6.3	0.3	CLASS A AMPLIFIER	100	0	—	—	1.6	50000	1520	80	—	—
						250	-2.0	—	—	0.9	66000	1500	100	—	—	
6SJ7(GT)	TRIPLE-GRID DETECTOR AMPLIFIER	6N	H	6.3	0.3	CLASS A AMPLIFIER	100	-3.0	100	0.9	2.0	700000	1575	—	—	—
						250	-3.0	100	0.6	3.0	1500000	1650	—	—	—	
6SK7(GT)	TRIPLE-GRID AMPLIFIER	8N	H	6.3	0.3	CLASS A AMPLIFIER	100	-3.0	100	2.6	8.9	250000	1900	—	—	—
						250	-3.0	100	2.4	9.2	800000	2000	—	—	—	

TYPE	DESIGN	SOCKET CONN.	CATHODE TYPE AND RATING			USED AS	PLATE SUPPLY VOLTS	GRID BIAS ② VOLTS	SCREEN SUPPLY VOLTS	SCREEN CURRENT MILLIAMPS	PLATE CURRENT MILLIAMPS	A.C. PLATE RESISTANCE OHMS	TRANSDUCTANCE (GRID-PLATE) μ MHOS	AMPLIFICATION FACTOR	LOAD FOR STATED POWER OUTPUT OHMS	POWER OUTPUT WATTS	
			C.T.	VOLTS	AMP.												
6SQ7(GT)	DUPLEX-DIODE HIGH-MU TRIODE	8Q	H	6.3	0.3	TRIODE UNIT AS CLASS A AMPLIFIER	250	-2.0	—	—	0.9	91000	1100	100	—	—	
							90 300	CATHODE BIAS, 11000 OHMS CATHODE BIAS, 3900 OHMS		GRID RESISTOR, ③ 0.5 MEGOHM		{ GAIN PER STAGE = 40 GAIN PER STAGE = 53					
6SR7	DUPLEX-DIODE TRIODE	8Q	H	6.3	0.3	TRIODE UNIT AS CLASS A AMPLIFIER	250	9.0	—	—	9.5	8500	1900	16	—	—	
6T5	SUPERSEDED BY TYPE 6U5/6G5																
6T6	R.F. AMPLIFIER PENTODE	6Z	H	8.3	0.45	CLASS A AMPLIFIER	250	-1.0	100	2.0	10.0	1000000	5500	—	—	—	
							250	-3.0	—	—	1.2	62000	1050	65	—	—	—
6T7-G	DUPLEX-DIODE HIGH-MU TRIODE	7V	H	6.3	0.15	TRIODE UNIT AS CLASS A AMPLIFIER	90 300	CATHODE BIAS, 8300 OHMS CATHODE BIAS, 4580 OHMS		GRID RESISTOR, ③ 0.5 MEGOHM		{ GAIN PER STAGE = 30 GAIN PER STAGE = 40		—	—		
							—	—	—	—	—	—	—	—			
6U5/6G5	ELECTRON-RAY TUBE	6R	H	6.3	0.3	VISUAL INDICATOR	PLATE & TARGET SUPPLY = 100 VOLTS. TRIODE PLATE RESISTOR = 0.5 MEG. TARGET CURRENT = 1.0 MA. GRID BIAS, -8 VOLTS; SHADOW ANGLE, 0°. BIAS, 0 VOLTS; ANGLE, 90°. PLATE CURRENT, 0.19 MA.									—	—
							PLATE & TARGET SUPPLY = 250 VOLTS. TRIODE PLATE RESISTOR = 1.0 MEG. TARGET CURRENT = 4.0 MA. GRID BIAS, -22 VOLTS; SHADOW ANGLE, 0°. BIAS, 0 VOLTS; ANGLE, 90°. PLATE CURRENT, 0.24 MA.									—	—
6U6-GT	BEAM POWER AMPLIFIER	7AC	H	6.3	0.75	CLASS A AMPLIFIER	200	-14.0	135	3.0	56.0	20000	6200	—	3000	5.5	
6U7-G	TRIPLE-GRID SUPER-CONTROL AMPLIFIER	7R	H	6.3	0.3	CLASS A AMPLIFIER	100	-3.0	100	2.2	8.0	250000	1500	—	—	—	
							250	-3.0	100	2.0	8.2	800000	1600	—	—	—	
						MIXER IN SUPERHETERODYNE	100	-10.0	100	—	—	OSCILLATOR PEAK VOLTS = 7.0					
							250	-10.0	100	—	—	—	—	—			
6V6(G)(GT)	BEAM POWER AMPLIFIER	7AC	H	6.3	0.45	SINGLE-TUBE CLASS A AMPLIFIER	180	-8.5	180	3.0	29.0	58000	3700	—	5500	2.0	
							315	-13.0	225	2.2	34.0	77000	3750	—	8500	5.5	
						PUSH-PULL CLASS AB ₁ AMPLIFIER	250	-15.0	250	5.0 ③	70.0 ③	—	—	—	10000	8.5 ⑫	
							300	-20.0	300	5.0 ③	76.0 ③	—	—	8000	13.0 ⑫		
6V7-G	DUPLEX-DIODE TRIODE	7V	H	6.3	0.3	TRIODE UNIT AS CLASS A AMPLIFIER	FOR OTHER CHARACTERISTICS, REFER TO TYPE 6S									—	—
6W6-GT	BEAM POWER AMPLIFIER	7AC	H	6.3	1.25	CLASS A AMPLIFIER	135	-9.5	135	—	58.0	—	9000	—	2000	3.3	
6W7-G	TRIPLE-GRID DETECTOR AMPLIFIER	7R	H	6.3	0.15	CLASS A AMPLIFIER	250	-3.0	100	0.5	2.0	1500000	1225	—	—	—	
6X5(G)(GT)	FULL-WAVE RECTIFIER	6S	H	6.3	0.6	WITH CONDENSER INPUT FILTER	MAX. A.C. VOLTS PER PLATE (RMS), 325 MAX. PEAK INVERSE VOLTS, 1250				MAX. D.C. OUTPUT MA., 70 MAX. PEAK PLATE MA., 210		MIN. TOTAL EFFECTIVE SUPPLY IMPEDANCE PER PLATE, 150 OHMS				
							MAX. A.C. VOLTS PER PLATE (RMS), 450 MAX. PEAK INVERSE VOLTS, 1250				MAX. D.C. OUTPUT MA., 70 MAX. PEAK PLATE MA., 210		MIN. VALUE OF INPUT CHOKE, 8 HENRIES				
6Y5	FULL-WAVE RECTIFIER ④	6J	H	6.3	0.8	RECTIFIER	MAX. A.C. VOLTS PER PLATE (RMS), 350 MAX. PEAK INVERSE VOLTS, 1500				MAX. D.C. OUTPUT MA., 50 MAX. PEAK PLATE MA., 200						
6Y6-G(GT)	BEAM POWER AMPLIFIER	7AC	H	6.3	1.25	SINGLE-TUBE CLASS A AMPLIFIER	135	-13.5	135	3.5	58.0	9300	7000	—	2000	3.6	
							200	-14.0	135	2.2	61.0	18300	7100	—	2600	6.0	
							—	0	—	—	7.6	—	—	—	7000	5.5	
6Y7-G	TWIN-TRIODE AMPLIFIER	8B	H	6.3	0.8	CLASS B AMPLIFIER	180	0	—	—	10.6	—	—	14000	8.0		

6Z4/84	REFER TO TYPE 84 DATA															
6Z5	FULL-WAVE RECTIFIER	6K	H	12.8 6.3	0.4 0.8	RECTIFIER	MAX. A.C. VOLTS PER PLATE (RMS), 230. MAX. D.C. OUTPUT MA., 60. MAX. PEAK INVERSE VOLTS, 1500.									
6Z7-G	TWIN-TRIODE AMPLIFIER	8B	H	6.3	0.3	CLASS B AMPLIFIER	135 180	0 D	—	—	POWER OUTPUT IS FOR ONE TUBE AT STATED PLATE-TO-PLATE LOAD.			9000 12000	2.5 4.2	
6ZY5-G	FULL-WAVE RECTIFIER	6S	H	6.3	0.3	WITH CONDENSER- INPUT FILTER	MAX. A.C. VOLTS PER PLATE (RMS), 325. MAX. PEAK INVERSE VOLTS, 1250			MAX. D.C. OUTPUT MA., 40 MAX. PEAK PLATE MA., 120		MIN. TOTAL EFFECTIVE SUPPLY IMPEADANCE PER PLATE, 225 Ω				
						WITH CHOKE- INPUT FILTER	MAX. A.C. VOLTS PER PLATE (RMS), 450 MAX. PEAK INVERSE VOLTS, 1250			MAX. D.C. OUTPUT MA., 40 MAX. PEAK PLATE MA., 120		MINIMUM VALUE OF INPUT CHOKE, 13.5 HENRIES.				
7A4	DETECTOR AMPLIFIER TRIODE	5AC	H	6.3	0.3	CLASS A AMPLIFIER	90 250	0 -6.0	—	—	10.0 9.0	6700 7700	3000 2600	20 20	—	
7A5	POWER AMPLIFIER PENTODE	6AA	H	6.3	0.7	CLASS A AMPLIFIER	110 125	-7.5 -9.0	110 125	3.0 3.2	35.0 37.5	16700 17000	6000 6100	—	2500 2700	1.4 1.9
7A6	TWIN DIODE	7AJ	H	6.3	0.15	DETECTOR RECTIFIER	MAXIMUM A.C. VOLTAGE PER PLATE150 VOLTS, RMS MAXIMUM D.C. OUTPUT CURRENT10 MILLIAMPERES									
7A7 (LM)	TRIPLE-GRID SUPER-CONTROL AMPLIFIER	8V	H	6.3	0.3	CLASS A AMPLIFIER	250	{-3.0 MIN.}	100	2.0	8.6	800000	2000	—	—	
7A8	OCTODE CONVERTER	8U	H	6.3	0.15	CONVERTER	250	{-3.0 MIN.}	100	2.8	3.0	700000	ANODE-GRID (#2): 250 [Ⓢ] MAX. VOLTS, 4.5 MA. OSCILLATOR-GRID (#1) RESISTOR, 50000 Ω CONV. TRANSCOND., 600 μMHOS.			
7B4	HIGH-μ TRIODE	5AC	H	6.3	0.3	CLASS A AMPLIFIER	100 230	-1.0 -2.0	—	—	0.5 0.9	85000 66000	1175 1500	100 100	—	
7B5 (LT)	POWER AMPLIFIER PENTODE	6AE	H	6.3	0.4	CLASS A AMPLIFIER	100 250 315	-7.0 -16.0 -21.0	100 250 250	1.6 5.5 4.0	9.0 32.0 25.5	1D4000 88000 75000	1500 2300 9000	—	12000 7600 9000	0.35 3.4 4.5
7B6 (LM)	DUPLEX-DIODE HIGH-μ TRIODE	6W	H	6.3	0.3	TRIODE UNIT AS AMPLIFIER	100 250	-1.0 -2.0	—	—	0.25 0.9	132000 91000	780 1100	100	—	
7B7	TRIPLE-GRID SUPER-CONTROL AMPLIFIER	6V	H	6.3	0.15	CLASS A AMPLIFIER	250	{-3.0 MIN.}	100	2.0	6.5	700000	1700	—	—	
7B8 (LM)	PENTAGRID CONVERTER	8X	H	6.3	0.3	CONVERTER	100 230	-1.5 -3.0	50 100	1.3 2.7	1.1 3.5	800000 380000	360 550	ANODE-GRID (#2) 250 [Ⓢ] MAX. VOLTS, 4.5 MA. OSCILLATOR- GRID (#1) RESISTOR, 50000 OHMS		
7C5 (LT)	BEAM POWER AMPLIFIER	8AA	H	6.3	0.45	CLASS A AMPLIFIER	FOR OTHER CHARACTERISTICS, REFER TO TYPE 6V6									
7C6	DUPLEX-DIODE HIGH-μ TRIODE	6W	H	6.3	0.15	TRIODE UNIT AS CLASS A AMPLIFIER	250	-1.0	—	—	1.3	100000	1000	100	—	
7C7	TRIPLE-GRID DETECTOR AMPLIFIER	6V	H	6.3	0.15	CLASS A AMPLIFIER	100 250	-3.0 -3.0	100 100	0.4 0.5	1.8 2.0	1200000 2000000	1225 1300	—	—	
7E6	DUPLEX-DIODE TRIODE	6W	H	6.3	0.3	TRIODE UNIT AS CLASS A AMPLIFIER	FOR OTHER CHARACTERISTICS, REFER TO TYPE 6R7									
7E7	DUPLEX-DIODE PENTODE	6AE	H	6.3	0.3	PENTODE UNIT AS R.F. OR A.F. AMPLIFIER	250	-3.0	100	1.6	7.5	700000	1300	—	—	
7F7	TWIN-TRIODE AMPLIFIER	8AC	H	6.3	0.3	EACH UNIT AS AMPLIFIER	250	-2.0	—	—	2.3	44000	1600	70	—	
7G7/1232	TRIPLE-GRID AMPLIFIER	6V	H	6.3	0.45	CLASS A AMPLIFIER	250	-2.0	100	2.0	6.0	800000	4500	—	—	

TYPE	DESIGN	SOCKET CONN.	CATHODE TYPE AND RATING			USED AS	PLATE SUPPLY VOLTS	GRID BIAS [Ⓢ] VOLTS	SCREEN SUPPLY VOLTS	SCREEN CURRENT MILLIAMPS	PLATE CURRENT MILLIAMPS	A.C. PLATE RESISTANCE OHMS	TRANSCONDUCTANCE (GRID-PLATE) μ MHOS	AMPLIFICATION FACTOR	LOAD FOR STATED POWER OUTPUT OHMS	POWER OUTPUT WATTS
			C.T.	VOLTS	AMP.											
7J7	TRIODE-HEXODE CONVERTER	8AR	H	6.3	0.3	CONVERTER	100 250	-3.0 -3.0	100 100	3.1 2.9	1.1 1.3	300000 1500000	260 300	TRIODE PLATE, 250 [Ⓢ] MAX. VOLTS, 5.4 MA. TRIODE GRID RESISTOR, 50000 Ω ; GRID CURRENT, 0.4 MA.		
7L7	TRIPLE-GRID AMPLIFIER	8V	H	6.3	0.3	CLASS A AMPLIFIER	250	-1.5	150	1.5	4.5	1000000	3100	—	—	—
7N7	TWIN-TRIODE AMPLIFIER	8AC	H	6.3	0.6	EACH UNIT AS AMPLIFIER	250	-6.0	—	—	9.0	7700	2600	20	—	—
7Q7	PENTAGRID CONVERTER	8AL	H	6.3	0.3	CONVERTER	FOR OTHER CHARACTERISTICS, REFER TO TYPE 6SA7									
7Y4	FULL-WAVE RECTIFIER	5AB	H	6.3	0.5	WITH CONDENSER-INPUT FILTER	MAX. A.C. VOLTS PER PLATE (RMS), MAX. PEAK INVERSE VOLTS, 1000		350	MAX. D.C. OUTPUT MA. 60 MAX. PEAK PLATE MA. PER PLATE, 250						
10	POWER AMPLIFIER TRIODE	4D	F	7.5	1.25	CLASS A AMPLIFIER	350 425	-32.0 -40.0	—	—	16.0 16.0	5150 3000	1550 1600	6.0 6.0	11000 10200	0.9 1.6
11 12	DETECTOR AMPLIFIER TRIODE ^①	4F 4D	D.C. F	1.1	0.25	CLASS A AMPLIFIER	90 135	-4.5 -10.5	—	—	2.5 3.0	15500 15000	425 440	6.6 6.6	—	—
12A5	POWER AMPLIFIER PENTODE	7F	H	6.3 12.6	0.6 0.3	CLASS A AMPLIFIER	100 160	-15.0 -25.0	100 160	3.0 8.0	6.0 14.0	50000 35000	1700 2400	—	4500 3300	0.6 3.4
12A6	POWER AMPLIFIER	7AC	H	12.6	0.15	CLASS A AMPLIFIER	250	-12.5	250	3.5	30.0	50000	3000	—	7500	2.5
12A7	RECTIFIER-PENTODE	7K	H	12.6	0.3	PENTODE UNIT AS CLASS A AMPLIFIER	135	-13.5	135	2.5	9.0	102000	975	—	13500	0.55
						HALF-WAVE RECTIFIER	MAXIMUM A.C. PLATE VOLTAGE 125 VOLTS, RMS MAXIMUM D.C. OUTPUT CURRENT 30 MILLIAMPERES									
12A8 (G) (GT)	PENTAGRID CONVERTER [Ⓢ]	8A	H	12.6	0.15	CONVERTER	FOR OTHER CHARACTERISTICS, REFER TO TYPE 6AB.									
12B7 (GL) (ML)	TRIPLE-GRID SUPER-CONTROL AMPLIFIER	8V	H	12.6	0.15	CLASS A AMPLIFIER	100 250	-3.0 -3.0	100 100	2.8 2.4	8.9 9.2	250000 800000	1900 2000	—	—	—
12B8-GT	TRIODE PENTODE	6T	H	12.6	0.3	TRIODE UNIT AS CLASS A AMPLIFIER	90 100	0 -1.0	—	—	2.6 0.6	37000 73000	2400 1500	90 110	—	—
						PENTODE UNIT AS CLASS A AMPLIFIER	90 100	-3.0 -3.0	90 100	2.0 2.0	7.0 8.0	170000 200000	1800 2100	360 360	—	—
12C8	DUPLEX-DIODE PENTODE	8E	H	12.6	0.15	PENTODE UNIT AS R.F. AMPLIFIER	250	-3.0	125	2.3	10.0	600000	1325	—	—	—
						PENTODE UNIT AS A.F. AMPLIFIER	90 [Ⓢ] 300 [Ⓢ]	CATHODE BIAS, 3500 OHMS. SCREEN RESISTOR= 1.1 MEG. CATHODE BIAS, 1600 OHMS. SCREEN RESISTOR= 1.2 MEG. }				GRID RESISTOR, 0.5 MEG OHM [Ⓢ]	GAIN PER STAGE = 55 GAIN PER STAGE = 79			
12E5-GT	AMPLIFIER TRIODE	6Q	H	12.6	0.15	CLASS A AMPLIFIER	250	-13.5	—	—	5.0	9500	1450	13.6	—	—
12F5-GT	HIGH- μ TRIODE	5M	H	12.6	0.15	CLASS A AMPLIFIER	FOR OTHER CHARACTERISTICS, REFER TO TYPE 6SF5.									
12G7-G (GT)	DUPLEX-DIODE HIGH- μ TRIODE	7V	H	12.6	0.15	TRIODE UNIT AS CLASS A AMPLIFIER	250	-3.0	—	—	—	56000	1200	70	—	—

12J5-GT	DETECTOR AMPLIFIER TRIODE	6Q	H	12.6	0.15	AMPLIFIER	FOR OTHER CHARACTERISTICS, REFER TO TYPE 6J5.									
12J7-GT	TRIPLE-GRID DETECTOR AMPLIFIER	7R	H	12.6	0.15	AMPLIFIER	"	"	"	"	"	"	"	"	6J7.	
12K7-G (GT)	TRIPLE-GRID SUPER-CONTROL AMPLIFIER	7R	H	12.6	0.15	AMPLIFIER	"	"	"	"	"	"	"	"	6K7.	
12K8(GT)	TRIODE-HEXODE CONVERTER	8K	H	12.6	0.15	OSCILLATOR MIXER	"	"	"	"	"	"	"	"	6K8.	
12Q7-G (GT)	DUPLEX-DIODE HIGH-MU TRIODE	7V	H	12.6	0.15	TRIODE UNIT AS AMPLIFIER	"	"	"	"	"	"	"	"	6Q7.	
12SA7	PENTAGRID CONVERTER (2b)	8R	H	12.6	0.15	MIXER	"	"	"	"	"	"	"	"	6SA7.	
12SC7	TWIN-TRIODE AMPLIFIER	8S	H	12.6	0.15	AMPLIFIER	"	"	"	"	"	"	"	"	6SC7.	
12SF5(GT)	HIGH-MU TRIODE	8AB	H	12.6	0.15	AMPLIFIER	"	"	"	"	"	"	"	"	6SF5.	
12SJ7(GT)	TRIPLE-GRID DETECTOR AMPLIFIER	8N	H	12.6	0.15	AMPLIFIER	"	"	"	"	"	"	"	"	6SJ7.	
12SK7(GT)	TRIPLE-GRID SUPER-CONTROL AMPLIFIER	6N	H	12.6	0.15	AMPLIFIER	"	"	"	"	"	"	"	"	6SK7.	
12SQ7(GT)	DUPLEX-DIODE HIGH-MU TRIODE	8Q	H	12.6	0.15	TRIODE UNIT AS AMPLIFIER	"	"	"	"	"	"	"	"	6SQ7.	
12SR7	DUPLEX-DIODE TRIODE	8Q	H	12.6	0.15	TRIODE UNIT AS AMPLIFIER	"	"	"	"	"	"	"	"	6R7.	
12Z3	HALF-WAVE RECTIFIER	4G	H	12.6	0.3	WITH CONDENSER- INPUT FILTER	MAX. A.C. PLATE VOLTS (RMS), 235 MAX. D.C. OUTPUT MA., 55				MIN. TOTAL EFFECTIVE PLATE-SUPPLY IMPEDANCE: UP TO 117 VOLTS, 0 OHMS; AT 150 VOLTS, 30 OHMS; AT 235 VOLTS, 75 OHMS.					
14B6	DUPLEX-DIODE HIGH-MU TRIODE	8W	H	12.6	0.15	TRIODE UNIT AS CLASS A AMPLIFIER	250	-2.0	—	—	0.9	91000	1100	100	—	—
14Q7	PENTAGRID CONVERTER	8AL	H	12.6	0.15	CONVERTER	250	-2.0	100	8.5	3.5	1000000	450	OSCILLATOR GRID (#1) RESISTOR, 20000 OHMS, OSCILLATOR GRID CURRENT, 0.5 MA.		
14J7	TRIODE-HEXODE CONVERTER	8AR	H	12.6	0.15	CONVERTER	FOR OTHER CHARACTERISTICS, REFER TO TYPE 7J7									
15	R.F. AMPLIFIER PENTODE	5F	D.C. H	2.0	0.22	CLASS A AMPLIFIER	67.5 135	-1.5 -1.5	67.5 67.5	0.3 0.3	1.65 1.65	830000 800000	710 750	—	—	—
18	POWER AMPLIFIER PENTODE	6B	H	14.0	0.3	CLASS A AMPLIFIER	FOR OTHER CHARACTERISTICS, REFER TO TYPE 6F6									
19	TWIN-TRIODE AMPLIFIER	6C	D.C. F	2.0	0.26	AMPLIFIER	" " " " " " " " 1J6-G									
20	POWER AMPLIFIER TRIODE	4D	D.C. F	3.3	0.132	CLASS A AMPLIFIER	90 135	-16.5 -22.5	—	—	3.0 6.5	8000 6300	415 525	3.3 3.3	9600 8500	0.045 0.110
20J8	TRIODE-HEPTODE CONVERTER	8H	H	20.0	0.15		FOR OTHER CHARACTERISTICS, REFER TO TYPE 6J8-G									
22	R.F. AMPLIFIER TETRODE	4K	D.C. F	3.3	0.132	SCREEN-GRID R.F. AMPLIFIER	135 135	-1.5 -1.5	45 67.5	0.6 27 1.3 27	1.7 3.7	725000 325000	375 500	—	—	—

TYPE	DESIGN	SOCKET CONN.	CATHODE TYPE AND RATING			USED AS	PLATE SUPPLY VOLTS	GRID BIAS VOLTS	SCREEN SUPPLY VOLTS	SCREEN CURRENT MILLIAMPS.	PLATE CURRENT MILLIAMPS.	A.C. PLATE RESISTANCE OHMS	TRANSCON- DUCTANCE, (GRID-PLATE) JMHOS	AMPLI- FICATION FACTOR	LOAD FOR STATED POWER OUTPUT OHMS	POWER OUTPUT WATTS	
			C.T.	VOLTS	AMP.												
24-A	R.F. AMPLIFIER PENTODE	5E	H	2.5	1.75	SCREEN-GRID R.F. AMPLIFIER	180 250	-3.0 -3.0	90 90	1.7 1.7	4.0 4.0	400000 800000	1000 1050	—	—	—	
						BIAS DETECTOR	250	{-5.0 APPROX}	20 TO 45	PLATE CURRENT, ADJUSTED TO 0.1 MA. WITH NO SIGNAL							
25A6(G) (GT)	POWER AMPLIFIER PENTODE	7S	H	25.0	0.3	CLASS A AMPLIFIER	95 180	-15.0 -18.0	95 120	4.0 8.0	20.0 33.0	45000 42000	2000 2375	—	4500 5000	0.9 2.2	
25A7-G (GT)	RECTIFIER- PENTODE	8F	H	25.0	0.3	PENTODE UNIT AS CLASS A AMPLIFIER	100	-15.0	100	4.0	20.5	50000	1800	—	4500	0.77	
						HALF-WAVE RECTIFIER	MAX. A.C. PLATE VOLTAGE 125 VOLTS, RMS MAX. D.C. OUTPUT CURRENT 75 MILLIAMPERES										
25AC5-G (GT)	HIGH-MU POWER AMPLIFIER TRIODE	6Q	H	25.0	0.3	CLASS B AMPLIFIER	180	0	—	4.0	—	—	—	4800	6.0		
						DYNAMIC-COUPLED AMP. WITH TYPE 6AE5-GT DRIVER	110	BIAS FOR BOTH 25AC5-GT AND 6AE5-GT DEVELOPED IN CIRCUIT. AVERAGE PLATE CURRENT OF DRIVER = 7 MILLIAMPERES. AVERAGE PLATE CURRENT OF 25AC5-GT = 45 MILLIAMPERES									
25B6-G	POWER AMPLIFIER PENTODE	7S	H	25.0	0.3	CLASS A AMPLIFIER	105 200	-16.0 -23.0	105 135	2.0 1.8	48.0 62.0	15500 18000	4800 5000	—	1700 2500	2.4 7.1	
25B8-GT	TRIODE- PENTODE	8T	H	25.0	0.15	PENTODE UNIT AS AMPLIFIER	100	-3.0	100	2.0	7.6	185000	2000	370	—	—	
						TRIODE UNIT AS AMPLIFIER	100	-1.0	—	—	0.6	75000	1500	112.5	—	—	
25C6-G	BEAM POWER AMPLIFIER	7AC	H	25.0	0.3	FOR OTHER CHARACTERISTICS, REFER TO TYPE 6Y8-G.											
25L6(G) (GT)	BEAM POWER AMPLIFIER	7AC	H	25.0	0.3	AMPLIFIER	" " " " " " 50L6-GT.										
25S/1B5	DUPLX-DIODE TRIODE	REFER TO TYPE 1B5 DATA															
25X6-GT	FULL-WAVE RECTIFIER	7Q	H	25.0	0.15	RECTIFIER	MAX. A.C. VOLTS PER PLATE (RMS), 250 MAX. D.C. OUTPUT CURRENT, 80 MA., WITH 10-OHM SERIES RESISTOR										
25Y4-GT	HALF-WAVE RECTIFIER	5AA	H	25.0	0.15	RECTIFIER	MAX. A.C. PLATE VOLTAGE 125 VOLTS, RMS MAX. D.C. OUTPUT CURRENT 75 MILLIAMPERES										
25Y5	RECTIFIER- DOUBLER	6E	H	25.0	0.3	RECTIFIER	MAX. A.C. VOLTS PER PLATE (RMS), 235 MAX. D.C. OUTPUT CURRENT 75 MILLIAMPERES										
25Z4-GT	HALF-WAVE RECTIFIER	5AA	H	25.0	0.3	RECTIFIER	MAX. A.C. PLATE VOLTAGE 125 VOLTS, RMS MAX. D.C. OUTPUT CURRENT 125 MILLIAMPERES										
25Z5	RECTIFIER- DOUBLER	6E	H	25.0	0.3	RECTIFIER- DOUBLER	FOR OTHER RATINGS, REFER TO TYPE 25Z6.										
25Z6	RECTIFIER- DOUBLER	7Q	H	25.0	0.3	VOLTAGE DOUBLER	MAX. A.C. VOLTS PER PLATE (RMS), 117 MAX. D.C. OUTPUT MA., 75				MIN. TOTAL EFFECTIVE PLATE-SUPPLY IMPEDANCE: HALF- WAVE, 30 OHMS; FULL-WAVE, 0 OHMS.						
						HALF-WAVE RECTIFIER	MAX. PLATE VOLTAGE (RMS), 235 MAX. D.C. OUTPUT MA. PER PLATE, 75				MIN. TOTAL EFFECTIVE SUPPLY IMPEDANCE PER PLATE: UP TO 117 VOLTS, 0 OHMS; AT 150 VOLTS, 40 OHMS; AT 235 VOLTS, 100 OHMS.						
26	AMPLIFIER- TRIODE	4D	F	1.5	1.05	CLASS A AMPLIFIER	90 180	-7.0 -14.5	—	—	2.9 8.2	8900 7300	935 1150	6.3 6.3	—	—	

27	DETECTOR AMPLIFIER TRIODE ①	5A	H	2.5	1.75	CLASS A AMPLIFIER	135 250	-9.0 -21.0	—	—	4.5 5.2	9000 9250	1000 975	9.0 9.0	—	—
						BIAS DETECTOR	250	{-30.0 APPROX.}	—	—	PLATE CURRENT ADJUSTED TO 0.2 MILLIAMPERE WITH NO SIGNAL.					
30	DETECTOR AMPLIFIER TRIODE ①	4D	D.C. F	2.0	0.06	AMPLIFIER	FOR OTHER CHARACTERISTICS, REFER TO TYPE 1H4-G.									
31	POWER AMPLIFIER TRIODE	4D	D.C. F	2.0	0.13	CLASS A AMPLIFIER	135 160	-22.5 -30.0	—	—	8.0 12.3	4100 3600	925 1050	3.8 3.8	7000 5700	0.185 0.375
32	R.F. AMPLIFIER TETRODE	4K	D.C. F	2.0	0.06	SCREEN-GRID R.F. AMPLIFIER	135 180	-3.0 -3.0	67.5 67.5	0.4 0.4 (27)	1.7 1.7	950000 1200000	640 650	—	—	—
						BIAS DETECTOR	180 (17)	{-6.0 APPROX.}	67.5	—	PLATE CURRENT ADJUSTED TO 0.2 MILLIAMPERE WITH NO SIGNAL.					
32L7-GT	RECTIFIER-BEAM POWER AMPLIFIER	8F	H	32.5	0.3	H.W. RECTIFIER	MAX. A.C. PLATE VOLTS (RMS), 125. MAX. D.C. OUTPUT CURRENT, 80 MILLIAMPERES									
33	POWER AMPLIFIER PENTODE	5K	D.C. F	2.0	0.26	CLASS A AMPLIFIER	110	-7.5	110	0.3	40.0	15000	8000	81	2600	1.0
						CLASS A AMPLIFIER	180	-18.0	180	5.0	22.0	55000	1700	—	6000	1.4
34	SUPER-CONTROL R.F. AMPLIFIER PENTODE	4M	D.C. F	2.0	0.06	SCREEN-GRID R.F. AMPLIFIER	135 180	{-3.0 MIN.}	67.5 67.5	1.0 1.0	2.8 2.8	800000 1000000	600 620	—	—	—
35/51	SUPER-CONTROL R.F. AMPLIFIER TETRODE	5E	H	2.5	1.75	SCREEN-GRID R.F. AMPLIFIER	180 250	{-3.0 MIN.}	90.0 90.0	2.5 2.5 (27)	6.3 6.5	300000 400000	1020 1050	—	—	—
35A5 (LT)	BEAM POWER AMPLIFIER	6AT	H	35.0	0.15	SINGLE-TUBE CLASS A AMPLIFIER	110	-7.5	110	3.0	40.0	14000	5800	—	2500	1.5
35L6-G (GT)	BEAM POWER AMPLIFIER	7AC	H	35.0	0.15	SINGLE-TUBE CLASS A AMPLIFIER	110	-7.5	110	3.0	40.0	13800	5800	—	2500	1.5
35Z3 (LT)	HALF-WAVE RECTIFIER	4Z	H	35.0	0.15	WITH CONDENSER-INPUT FILTER	MAX. A.C. PLATE VOLTS (RMS), 235 MAX. D.C. OUTPUT MA., 100				MIN. TOTAL EFFECTIVE PLATE-SUPPLY IMPEDANCE: UP TO 117 VOLTS, 0 OHMS; AT 150 VOLTS, 40 OHMS; AT 235 VOLTS, 100 OHMS.					
35Z4-GT	HALF-WAVE RECTIFIER	5AA	H	35.0	0.15	WITH CONDENSER-INPUT FILTER	MAX. A.C. PLATE VOLTS (RMS), 250 (22) MAX. PEAK INVERSE VOLTS, 720				MAX. D.C. OUTPUT MA., 100 MAX. PEAK PLATE MA., 800					
35Z5-G (GT)	HALF-WAVE RECTIFIER <i>Heater Tap for Pilot</i>	6AD	H	35.0	0.15	WITH CONDENSER-INPUT FILTER	MAX. A.C. PLATE VOLTS (RMS), 235; MIN. TOTAL EFFECTIVE PLATE-SUPPLY IMPEDANCE: UP TO 117 VOLTS, 0 OHMS; AT 235 VOLTS, 45 OHMS. MAX. D.C. OUTPUT MA. WITH PILOT AND NO SHUNT RESISTOR, 80; WITH PILOT AND SHUNT RESISTOR, 100; WITHOUT PILOT, 100.									
35Z6-G	RECTIFIER-DOUBLER	7Q	H	35.0	0.3	RECTIFIER-DOUBLER	MAX. A.C. VOLTS PER PLATE (RMS), 235 MAX. D.C. OUTPUT MA., 110									
36	R.F. AMPLIFIER TETRODE	5E	H	6.3	0.3	SCREEN-GRID R.F. AMPLIFIER	100 250	-1.5 -3.0	55 90	— 1.7 (27)	1.6 3.2	550000 550000	850 1080	—	—	—
						BIAS DETECTOR	100 (16) 250 (16)	-5.0 -8.0	55 90	—	GRID-BIAS VALUES ARE APPROXIMATE. PLATE CURRENT ADJUSTED TO 0.1 MILLIAMPERE WITH NO SIGNAL.					
37	DETECTOR AMPLIFIER TRIODE ①	5A	H	6.3	0.3	CLASS A AMPLIFIER	90 250	-8.0 -18.0	—	—	2.5 7.5	11500 8400	800 1100	9.2 9.2	—	—
						BIAS DETECTOR	90 250	-10.0 -28.0	—	—	GRID BIAS VALUES ARE APPROXIMATE. PLATE CURRENT ADJUSTED TO 0.2 MILLIAMPERE WITH NO SIGNAL.					
38	POWER AMPLIFIER PENTODE	5F	H	6.3	0.3	CLASS A AMPLIFIER	100 250	-9.0 -25.0	100 250	1.2 3.6	7.0 22.0	140000 100000	875 1200	—	15000 10000	0.27 2.50
39/44	SUPER-CONTROL R.F. AMPLIFIER PENTODE	5F	H	6.3	0.3	CLASS A AMPLIFIER	90 250	{-3.0 MIN.}	90 90	1.6 1.4	5.6 5.8	375000 1000000	980 1050	—	—	—
40	VOLTAGE AMPLIFIER TRIODE	4D	D.C. F	5.0	0.25	CLASS A AMPLIFIER	135 (18) 180 (18)	-1.5 -3.0	—	—	0.2 0.2	150000 150000	200 200	30 30	—	—

TYPE	DESIGN	SOCKET CONN.	CATHODE TYPE AND RATING			USED AS	PLATE SUPPLY VOLTS	GRID BIAS ② VOLTS	SCREEN SUPPLY VOLTS	SCREEN CURRENT MILLIAMP.	PLATE CURRENT MILLIAMP.	A.C. PLATE RESISTANCE OHMS	TRANSCON- DUCTANCE (GRID-PLATE) UMHOS	AMPLI- FICATION FACTOR	LOAD FOR STATED POWER OUTPUT OHMS	POWER OUTPUT WATTS	
			C.T.	VOLTS	AMP.												
40Z5 / 45Z5-GT	HALF-WAVE RECTIFIER	REFER TO TYPE 45Z5-GT DATA															
41	POWER AMPLIFIER PENTODE	6B	H	6.3	0.4	AMPLIFIER	FOR OTHER CHARACTERISTICS, REFER TO TYPE 6K6-G.										
42	POWER AMPLIFIER PENTODE	6B	H	6.3	0.7	AMPLIFIER	"	"	"	"	"	"	"	"	8F6.		
43	POWER AMPLIFIER PENTODE	6B	H	25.0	0.3	AMPLIFIER	"	"	"	"	"	"	"	"	25A6.		
44	SUPER-CONTROL R.F. AMPLIFIER PENTODE	REFER TO TYPE 39/44 DATA															
45	POWER AMPLIFIER TRIODE	4D	F	2.5	1.5	CLASS A AMPLIFIER	180 275	-31.5 -56.0	—	—	31.0 36.0	1650 1700	2125 2050	3.5 3.5	2700 4600	0.82 2.0	
						PUSH-PULL CLASS AB ₂ AMPLIFIER	275 275	CATHODE BIAS, 775 OHMS ⑬			36.0 ⑬ 26.0 ⑬	—	—	—	5060 3200	12.0 ⑭ 18.0 ⑭	
45Z5-GT	HALF-WAVE RECTIFIER <i>Heater Tap for Pilot</i>	6AD	H	45.0	0.15	WITHOUT PILOT	MAX. A.C. PLATE VOLTS (RMS), 250 22			MAX. PEAK PLATE MA., 800			MAX. D.C. OUTPUT MA., 100				
						WITH PILOT	MAX. A.C. PLATE VOLTS RMS 250 22			MAX. D.C. OUTPUT MA., 60							
46	DUAL-GRID POWER AMPLIFIER	5C	F	2.5	1.75	CLASS A AMPLIFIER ⑰	250 300 400	-33.0 0	—	—	22.0 8.0 ⑬ 12.0 ⑬	2380	2350	5.6	6400 5200 5800	1.25 16.0 ⑭ 20.0 ⑭	
						CLASS B AMPLIFIER ⑱	400	0	—	—	—	—	—	—	—	—	—
47	POWER AMPLIFIER PENTODE	5B	F	2.5	1.75	CLASS A AMPLIFIER	250	-18.5	250	6.0	31.0	60000	2500	—	7000	2.7	
48	POWER AMPLIFIER TETRODE	6A	D.C. H	30.0	0.4	TETRODE CLASS A AMPLIFIER	96 125	-19.0 -20.0	96 100	9.0 9.5	52.0 56.0	—	3600 3900	—	1500 1500	2.0 2.5	
						TETRODE PUSH-PULL CLASS A AMPLIFIER	125	-20.0	100	—	100 ⑬	—	—	—	—	—	—
49	DUAL-GRID POWER AMPLIFIER	5C	D.C. F	2.0	0.12	CLASS A AMPLIFIER ⑰	135	-20.0	—	—	6.0	4175	1125	4.7	11000	0.17	
						CLASS B AMPLIFIER ⑱	180	0	—	—	4.0 ⑬	—	—	—	—	—	—
50	POWER AMPLIFIER TRIODE	4D	F	7.5	1.25	CLASS A AMPLIFIER	300 400 450	-54.0 -70.0 -84.0	—	—	35.0 55.0 55.0	2000 1800 1800	1900 2100 2100	3.8 3.8 3.8	4600 3670 4350	1.6 3.4 4.6	
50C6-G	BEAM POWER AMPLIFIER	7AC	H	50.0	0.15	AMPLIFIER	FOR OTHER CHARACTERISTICS, REFER TO TYPE 6Y6-G.										
50L6-GT	BEAM POWER AMPLIFIER	7AC	H	50.0	0.15	SINGLE-TUBE CLASS A AMPLIFIER	110 110	-7.5 -7.5	110 110	4.0 4.0	49.0 49.0	10000 10000	6200 6200	—	1500 2000	2.1 2.2	
50Y6-G(GT)	RECTIFIER DOUBLER	7Q	H	50.0	0.15	RECTIFIER DOUBLER	MAX. A.C. PLATE VOLTS (RMS), 125 MAX. D.C. OUTPUT MA., 85										
50Z6-G	FULL-WAVE RECTIFIER	7Q	H	50.0	0.3	RECTIFIER	MAX. A.C. PLATE VOLTS (RMS), 250 MAX. D.C. OUTPUT MA., 250										
50Z7-G	RECTIFIER DOUBLER	8AN	H	50.0	0.15	RECTIFIER DOUBLER	MAX. A.C. PLATE VOLTS (RMS), 117. MAX. D.C. OUTPUT CURRENT WHEN USED WITH 2.9-VOLT 0.17-AMP. PANEL LAMP, 65 MILLIAMPERES.										

51	SUPER-CONTROL R.F. AMPLIFIER TETRODE	REFER TO TYPE 35/51 DATA															
52	DUAL-GRID POWER AMPLIFIER	5C	F	6.3	0.3	CLASS A AMPLIFIER (21)	110	0	—	—	43.0	1750	3000	5.2	2000	1.5	
						CLASS B AMPLIFIER (22)	180	0	—	—	3.0 (13)	—	—	—	—	10000	5.0 (12)
53	TWIN-TRIODE AMPLIFIER	7B	H	2.5	2.0	AMPLIFIER	FOR OTHER CHARACTERISTICS, REFER TO TYPE 6N7.										
55	DUPLEX-DIODE TRIODE	6G	H	2.5	1.0	TRIODE UNIT AS AMPLIFIER	"	"	"	"	"	"	"	"	"	"	85.
56	DETECTOR AMPLIFIER TRIODE (1)	5A	H	2.5	1.0	AMPLIFIER DETECTOR	"	"	"	"	"	"	"	"	"	"	6P5-G.
57	TRIPLE-GRID DETECTOR AMPLIFIER	6F	H	2.5	1.0	AMPLIFIER DETECTOR	"	"	"	"	"	"	"	"	"	"	6J7.
58	TRIPLE-GRID SUPER-CONTROL AMPLIFIER	6F	H	2.5	1.0	AMPLIFIER MIXER	"	"	"	"	"	"	"	"	"	"	6U7-G.
59	TRIPLE-GRID POWER AMPLIFIER	7A	H	2.5	2.0	TRIODE (6) CLASS A AMPLIFIER	250	-28.0	—	—	26.0	2300	2600	6.0	5000	1.25	
						PENTODE (5) CLASS A AMPLIFIER	250	-18.0	250	9.0	35.0	40000	2500	—	6000	3.0	
						TRIODE (7) CLASS B AMPLIFIER	300 400	0 0	—	—	26.0 (13) 26.0 (13)	—	—	—	4600 6000	15.0 (12) 20.0 (12)	
70A7-GT	RECTIFIER-BEAM POWER AMPLIFIER <i>Heater Tap for Pilot</i>	8E	H	70	0.3	HALF-WAVE RECTIFIER	MAX. A.C. PLATE VOLTS (RMS), 125. MAX. D.C. OUTPUT CURRENT, 60 MA.										
						CLASS A AMPLIFIER	110	-7.5	110	3.0	40.0	—	5600	80	2500	1.5	
70L7-GT	RECTIFIER-BEAM POWER AMPLIFIER	8AA	H	70	0.15	HALF-WAVE RECTIFIER	MAX. A.C. PLATE VOLTS (RMS), 117. MAX. D.C. OUTPUT CURRENT, 70 MA.										
						CLASS A AMPLIFIER	110	-7.5	110	3.0	43.0	15000	7000	—	2000	1.8	
71-A	POWER AMPLIFIER TRIODE	4D	F	5.0	0.25	CLASS A AMPLIFIER	90 180	-19.0 -43.0	—	—	10.0 20.0	2170 1750	1400 1700	3.0 3.0	3000 4800	0.125 0.790	
75	DUPLEX-DIODE HIGH-MU TRIODE	6G	H	6.3	0.3	AMPLIFIER	FOR OTHER CHARACTERISTICS, REFER TO TYPE 6SQ7.										
76	DETECTOR AMPLIFIER TRIODE (1)	5A	H	6.3	0.3	AMPLIFIER DETECTOR	"	"	"	"	"	"	"	"	"	"	6P5-G.
77	TRIPLE-GRID DETECTOR AMPLIFIER	8F	H	6.3	0.3	CLASS A AMPLIFIER	100 250	-1.5 -3.0	80 100	0.4 0.5	1.7 2.3	600000 1000000 (23)	1100 1250	—	—	—	
						BIAS DETECTOR	250	-1.95	50	CATHODE CURRENT 0.85 MA.		—	PLATE RESISTOR, 250 000 OHMS. GRID RESISTOR, 250 000 OHMS.				
78	TRIPLE-GRID SUPER-CONTROL AMPLIFIER	6F	H	6.3	0.3	AMPLIFIER MIXER	FOR OTHER CHARACTERISTICS, REFER TO TYPE 6K7.										
79	TWIN-TRIODE AMPLIFIER	6H	H	6.3	0.6	CLASS B AMPLIFIER	180 250	0 0	—	—	POWER OUTPUT IS FOR ONE TUBE AT STATED PLATE-TO-PLATE LOAD				7000 14000	3.5 8.0	
80	FULL-WAVE RECTIFIER	4C	F	5.0	2.0	RECTIFIER	FOR OTHER CHARACTERISTICS, REFER TO TYPE 5Y3-G.										
81	HALF-WAVE RECTIFIER	4B	F	7.5	1.25	WITH CONDENSER-INPUT FILTER	MAX. A.C. PLATE VOLTS (RMS), 700. MAX. PEAK INVERSE VOLTS, 2000				MAX. D.C. OUTPUT MA., 85 MAX. PEAK PLATE MA., 500						

TYPE	DESIGN	SOCKET CONN.	CATHODE TYPE AND RATING			USED AS	PLATE SUPPLY VOLTS	GRID BIAS ② VOLTS	SCREEN SUPPLY VOLTS	SCREEN CURRENT MILLIAMP.	PLATE CURRENT MILLIAMP.	A.C. PLATE RESISTANCE OHMS	TRANSCONDUCTANCE (GRID-PLATE) μ MHOS	AMPLIFICATION FACTOR	LOAD FOR STATED POWER OUTPUT OHMS	POWER OUTPUT WATTS
			C.T.	VOLTS	AMP.											
82	FULL-WAVE RECTIFIER ④	4C	F	2.5	3.0	WITH CONDENSER-INPUT FILTER	MAX. A.C. VOLTS PER PLATE (RMS), 450 MAX. PEAK INVERSE VOLTS, 1550			MAX. D.C. OUTPUT MA, 115 MAX. PEAK PLATE MA, 345			MIN. TOTAL EFFECTIVE SUPPLY IMPEDANCE PER PLATE, 50 OHMS			
						WITH CHOKE-INPUT FILTER	MAX. A.C. VOLTS PER PLATE (RMS), 550 MAX. PEAK INVERSE VOLTS, 1550			MAX. D.C. OUTPUT MA, 115 MAX. PEAK PLATE MA, 345			MINIMUM VALUE OF INPUT CHOKE, 6 HENRIES			
83	FULL-WAVE RECTIFIER ④	4C	F	5.0	3.0	WITH CONDENSER-INPUT FILTER	MAX. A.C. VOLTS PER PLATE (RMS), 450 MAX. PEAK INVERSE VOLTS, 1550			MAX. D.C. OUTPUT MA, 225 MAX. PEAK PLATE MA, 675			MIN. TOTAL EFFECTIVE SUPPLY IMPEDANCE PER PLATE, 50 OHMS			
						WITH CHOKE-INPUT FILTER	MAX. A.C. VOLTS PER PLATE (RMS), 550 MAX. PEAK INVERSE VOLTS, 1550			MAX. D.C. OUTPUT MA, 225 MAX. PEAK PLATE MA, 675			MINIMUM VALUE OF INPUT CHOKE, 3 HENRIES			
83-V	FULL-WAVE RECTIFIER	4AD	H	5.0	2.0	FOR OTHER RATINGS, REFER TO TYPE 5V4-G.										
84/6Z4	FULL-WAVE RECTIFIER	5D	H	6.3	0.5	WITH CONDENSER-INPUT FILTER	MAX. A.C. VOLTS PER PLATE (RMS), 325 MAX. PEAK INVERSE VOLTS, 1250			MAX. D.C. OUTPUT MA, 80 MAX. PEAK PLATE MA, 180			MIN. TOTAL EFFECTIVE SUPPLY IMPEDANCE PER PLATE, 85 OHMS			
						WITH CHOKE-INPUT FILTER	MAX. A.C. VOLTS PER PLATE (RMS), 450 MAX. PEAK INVERSE VOLTS, 1250			MAX. D.C. OUTPUT MA, 60 MAX. PEAK PLATE MA, 180			MINIMUM VALUE OF INPUT CHOKE, 10 HENRIES			
85	DUPLEX-DIODE TRIODE	6G	H	6.3	0.3	TRIODE UNIT AS CLASS A AMPLIFIER	135 250	-10.5 -20.0	—	—	3.7 8.0	11000 7500	750 1100	6.3 6.3	25000 20000	0.075 0.350
89	TRIPLE-GRID POWER AMPLIFIER	6F	H	6.3	0.4	AS TRIODE ⑥ CLASS A AMPLIFIER	160 250	-20.0 -31.0	—	—	17.0 32.0	3300 2600	1425 1800	4.7 4.7	7000 5500	0.30 0.90
						AS PENTODE ⑤ CLASS A AMPLIFIER	100 250	-10.0 -25.0	100 250	1.6 5.5	9.5 32.0	104000 70000	1200 1800	—	10700 6750	0.33 3.40
						AS TRIODE ⑦ CLASS B AMPLIFIER	160	0	—	—	6.0 ⑬	—	—	—	13600 9400	2.50 ⑭ 3.50 ⑭
V-99 X-99	DETECTOR AMPLIFIER TRIODE ①	4E 4D	D.C. F	3.3	0.063	CLASS A AMPLIFIER	90	-4.5	—	—	2.5	15500	425	6.6	—	—
112-A	DETECTOR AMPLIFIER TRIODE ①	4D	D.C. F	5.0	0.25	CLASS A AMPLIFIER	90 180	-4.5 -13.5	—	—	5.0 7.7	5400 4700	1575 1800	6.5 6.5	—	—
117L7-GT	RECTIFIER-BEAM POWER AMPLIFIER <i>Heater Tap for Pilot</i>	6A0	H	117	0.09	HALF-WAVE RECTIFIER	MAX. A.C. PLATE VOLTS (RMS), 117. MAX. D.C. OUTPUT CURRENT, 75 MA.									
						CLASS A AMPLIFIER	105	-5.5	105	4.0	45.0	20000	4000	—	4000	5.5
117M7-GT	RECTIFIER-BEAM POWER AMPLIFIER	6A0	H	117	0.09	HALF-WAVE RECTIFIER	MAX. A.C. PLATE VOLTS (RMS), 117. MAX. D.C. OUTPUT CURRENT, 75 MA.									
						CLASS A AMPLIFIER	100	-5.5	100	4.0	45.0	15000	6500	—	2000	1.0
117N7-GT	RECTIFIER-BEAM POWER AMPLIFIER	6AV	H	117	0.09	HALF-WAVE RECTIFIER	MAX. A.C. PLATE VOLTS (RMS), 117. MAX. D.C. OUTPUT CURRENT, 75 MA.									
						CLASS A AMPLIFIER	100	-6.0	100	5.0	51.0	16000	7000	—	3000	1.2
117Z6-G GT	RECTIFIER DOUBLER	7Q	H	117	0.075	VOLTAGE DOUBLER	MAX. A.C. VOLTS PER PLATE (RMS), 117 MAX. D.C. OUTPUT MA, 80			MIN. TOTAL EFFECTIVE POWER SUPPLY IMPEDANCE: HALF-WAVE, 30 OHMS; FULL-WAVE, 15 OHMS.						
						HALF-WAVE RECTIFIER	MAX. A.C. VOLTS PLATE (RMS), 235 MAX. D.C. OUTPUT MA., PER PLATE, 60			MIN. TOTAL EFFECTIVE POWER SUPPLY IMPEDANCE PER PLATE: UP TO 117 VOLTS, 15 OHMS; AT 150 VOLTS, 40 OHMS; AT 235 VOLTS, 100 OHMS						
1231	TRIPLE-GRID AMPLIFIER	6V	H	6.3	0.45	USED AS PENTODE ⑤ CLASS A AMPLIFIER	300	200 Ω CATH. RESISTOR	150	2.5	10.0	700000	5500	3850	—	—
						USED AS TRODE ⑥ CLASS A AMPLIFIER ⑥	300	200 Ω CATH. RESISTOR	150	0.5	12.0	540000	6500	3500	—	—
						USED AS TRIODE CLASS A AMPLIFIER ⑥	250	400 Ω CATH. RESISTOR	—	—	13.0	5200	6300	33	—	—

1232	TRIPLE-GRID AMPLIFIER	REFER TO TYPE 7G7/1232 DATA											
1851	TELEVISION AMPLIFIER PENTODE	7R	H	8.3	0.45	CLASS A AMPLIFIER	FOR OTHER CHARACTERISTICS, REFER TO TYPE 6AC7/1852						
1852	TELEVISION AMPLIFIER PENTODE	REFER TO TYPE 8AC7/1852 DATA											
1853	TELEVISION AMPLIFIER PENTODE	" " " 8AB7/1853 "											

MISCELLANEOUS AND SPECIAL-PURPOSE TUBES

TYPE	DESIGN	SOCKET CONN.	CATHODE TYPE AND RATING			USED AS	PLATE SUPPLY VOLTS	GRID BIAS VOLTS	SCREEN SUPPLY VOLTS	SCREEN CURRENT MILLIAMP.	PLATE CURRENT MILLIAMP.	A.C. PLATE RESISTANCE OHMS	TRANS- CON- DUCTANCE (GRID-PLATE) JUMHOS	AMPLI- FICATION FACTOR	LOAD FOR STATED POWER OUTPUT OHMS	POWER OUTPUT WATTS		
			C.T.	VOLTS	AMP.													
2A4-G	ARGON-FILLED THYRATRON	5S	F	2.5	2.5	CONTROL TUBE	200	AVERAGE ANODE CURRENT, 100 MA. PEAK ANODE CURRENT, 1.25 AMP. TUBE DROP, 15 VOLTS. COLD STARTING TIME, 2 SECONDS										
2V3-G	HALF-WAVE RECTIFIER	4Y	F	2.5	5.0	RECTIFIER	MAX. PEAK INVERSE PLATE VOLTS 16500. MAX. PEAK PLATE CURRENT, 12 MA. AVERAGE PLATE CURRENT, 2 MA.											
2X2/879	HALF-WAVE RECTIFIER	4AB	H	2.5	1.75	RECTIFIER	MAX. A.C. PLATE VOLTS (RMS), 4500			MAX. D.C. OUTPUT MA., 7.5			MAX. PEAK INVERSE VOLTS, 12500			MAX. PEAK PLATE MA., 100		
2Z2/G84	HALF-WAVE RECTIFIER	4B	F	2.5	1.50	RECTIFIER	MAX. A.C. PLATE VOLTS (RMS), 350			MAX. D.C. OUTPUT CURRENT, 50 MA.								
RK-62	GAS TRIODE DET. THYRATRON	4D	F	1.4	0.05	SUPER-REGEN.-DETECTOR CONTROL-TUBE	45				1.5	RELAY RESISTANCE, 5000 TO 10000 OHMS. AVERAGE ANODE DROP, 30 VOLTS.						
VR75-30	GAS-FILLED REGULATOR	4W	COLD	—	—	VOLTAGE REGULATOR	MIN. STARTING VOLTAGE, 105 VOLTS. OPERATING VOLTAGE, 75 VOLTS OPERATING CURRENT: MINIMUM, 5 MA.; MAXIMUM, 30 MA.											
G84	HALF-WAVE RECTIFIER	REFER TO TYPE 2X2/G84 DATA																
VR90-30	GAS-FILLED REGULATOR	4W	COLD	—	—	VOLTAGE REGULATOR	MIN. STARTING VOLTAGE, 125 VOLTS. OPERATING VOLTAGE, 90 VOLTS. OPERATING CURRENT: MINIMUM, 10 MA.; MAXIMUM, 30 MA.											
VR105-30	GAS-FILLED REGULATOR	4W	COLD	—	—	VOLTAGE REGULATOR	MIN. STARTING VOLTAGE, 137 VOLTS. OPERATING VOLTAGE, 105 VOLTS. OPERATING CURRENT: MINIMUM, 5 MA.; MAXIMUM, 30 MA.											
HY-113	MINIATURE TRIODE	SPECIAL	D.C. F	1.4	0.70	OSCILLATOR DETECTOR	45	-4.5	—	—	0.4	25000	250	6.3	—	—		
HY-114	TRIODE	SPECIAL	D.F. F	1.4	0.12	U.H.F. OSCILLATOR DETECTOR AMPLIFIER	180	OSCILLATOR GRID CURRENT, 3 MA.			15.0	20000	1000	20	—	—		
HY-115	MINIATURE PENTODE (31)	SPECIAL	D.F. F	1.4	0.70	VOLTAGE AMPLIFIER	45	-1.5	22.5	0.008	0.03	5 200 000	56	300	—	—		
HY-125	MINIATURE PENTODE (31)	SPECIAL	D.C. F	1.4	0.70	A.F. OUTPUT AMPLIFIER	45	-3.0	45	0.2	0.9	—	—	225	50000	0.0115		
VR150-30	GAS-FILLED REGULATOR	4W	COLD	—	—	VOLTAGE REGULATOR	MIN. STARTING VOLTAGE, 180 VOLTS. OPERATING VOLTAGE, 150 VOLTS. OPERATING CURRENT: MINIMUM, 5 MA.; MAXIMUM, 30 MA.											
CK-501 (X) (32)	MINIATURE PENTODE (31)	SPECIAL	D.C. F	1.25	0.033	VOLTAGE AMPLIFIER	30 45	0 -1.25	30 45	0.06 0.06	0.3 0.3	1000 000 1500 000	325 300	—	—	—		
CK-502 (X) (32)	MINIATURE PENTODE (31)	SPECIAL	D.C. F	1.25	0.033	A.F. OUTPUT AMPLIFIER (33)	30 45	0 -1.25	30 45	0.06 0.06	0.55 0.6	500 000 700 000	400 500	—	80000 80000	0.0035 0.011		
CK-503 (X) (32)	MINIATURE PENTODE (31)	SPECIAL	D.C. F	1.25	0.033	A.F. OUTPUT AMPLIFIER (34)	30	0	30	0.35	1.5	150000	600	—	20000	0.007		
CK-504 (X) (32)	MINIATURE PENTODE (31)	SPECIAL	D.C. F	1.25	0.033	A.F. OUTPUT AMPLIFIER (33)	30	0	30	0.09	0.4	500000	350	—	60000	0.0045		

CK-505 (X) (62)	MINIATURE PENTODE (31)	SPECIAL	D.C. F	0.625	0.03	IMPEDANCE-COUPLED VOLTAGE AMPLIFIER	30 45	0 -1.25	30 40	0.07 0.06	0.17 0.2	1 100 000 2 000 000	140 150	—	—	—	
						RESISTANCE-COUPLED VOLTAGE AMPLIFIER	30	0	30	0.007	0.02	GAIN PER STAGE = 15					
HY-615	TRIODE	SPECIAL	H	6.3	0.15	U.H.F. OSCILLATOR DETECTOR AMPLIFIER	300	OSCILLATOR GRID CURRENT, 3 MA.			20	20000	2200	22	—	—	4.0
864	NON-MICROPHONIC TRIODE	4D	D.F.	1.1	0.25	CLASS A AMPLIFIER	190 135	-4.5 -9.0	—	—	2.9 3.5	13500 12 700	610 645	8.2 8.2	—	—	
874	GAS-FILLED REGULATOR	SPECIAL	COLD	—	—	VOLTAGE REGULATOR	MINIMUM STARTING VOLTAGE, 125 VOLTS. OPERATING VOLTAGE, 90 VOLTS. OPERATING CURRENT: MINIMUM, 10 MA.; MAXIMUM, 50 MA.										
878	HALF-WAVE RECTIFIER	4AB	F	2.5	5.0	RECTIFIER	MAX. PEAK INVERSE PLATE VOLTS, 20000. MAX. A.C. PLATE VOLTAGE (RMS), 7100. MAX. D.C. OUTPUT CURRENT, 5 MA.										
879	HALF-WAVE RECTIFIER	REFER TO TYPE 2X2/879 DATA															
884 885	GAS TRIODE	6Q	H	6.3	0.6	SWEEP OSCILLATOR	INSTANTANEOUS ANODE VOLTS, 300. MAX. PEAK ANODE CURRENT, 300 MA. AVERAGE ANODE CURRENT: 2-3 MA.										
		5A.	H	2.5	1.4	GRID-CONTROLLED RECTIFIER	MAX. PEAK VOLTAGE BETWEEN ANY TWO ELECTRODES, 350 VOLTS. MAX. PEAK ANODE CURRENT, 300 MA. MAX. AVERAGE ANODE CURRENT, 75 MA. GRID RESISTOR: LESS THAN 1000 OHMS PER INSTANTANEOUS GRID VOLT.										
954	ACORN PENTODE DETECTOR- AMPLIFIER	1	H	6.3	0.15	CLASS A AMPLIFIER	90 250	-3.0 -3.0	90 100	0.5 0.7	1.2 2.0	1000 000 1 500 000 +	1100 1400	1100 2000 +	—	—	
955	ACORN TRIODE DETECTOR- AMPLIFIER- OSCILLATOR	2	H	6.3	0.15	CLASS A AMPLIFIER	90 135 180	-2.5 -3.75 -5.0	—	—	2.5 3.5 4.5	14700 13 200 12 500	25 25 25	— — 20000	— — 0.135		
						CLASS C AMP. - OSC.	180	-35, APPROX.	MAX. GRID CURRENT, 2 MA.	8, MAX.						0.5	
956	ACORN SUPER-CONTROL R.F. AMPLIFIER PENTODE	1	H	6.3	0.15	CLASS A AMPLIFIER	250	-3.0	100	1.8	5.5	800 000	1800	1440	—	—	
						MIXER IN SUPERHETERODYNE	100 250	-10.0 -10.0	100 100	OSCILLATOR PEAK VOLTS = 7.0					—	—	
957	ACORN TRIODE DETECTOR- AMPLIFIER- OSCILLATOR	3	D.C. F	1.25	0.05	CLASS A AMPLIFIER	135	-5.0	—	—	2.0	24 000	650	16	—	—	
958	ACORN TRIODE A.F. AMPLIFIER OSCILLATOR	3	D.C. F	1.25	0.10	CLASS A AMPLIFIER	135	-7.5	—	—	3.0	10 000	1200	12	—	—	
959	ACORN PENTODE DETECTOR- AMPLIFIER	4	D.C. F	1.25	0.05	CLASS A AMPLIFIER	135	-3.0	67.5	0.4	1.7	800 000	600	400	—	—	
991	GAS-FILLED REGULATOR	BAYONET CANDELABRA	COLD	—	—	VOLTAGE REGULATOR	MINIMUM STARTING VOLTAGE, 67 VOLTS. OPERATING VOLTAGE, 48 TO 67 VOLTS. OPERATING CURRENT: MINIMUM 0.5 MA.; MAXIMUM, 2 MA.										
1221 1223	NON-MICROPHONIC PENTODE	6F 7R	H	6.3	0.3	CLASS A AMPLIFIER	FOR OTHER CHARACTERISTICS, REFER TO TYPE 6J7										
1602	NON-MICROPHONIC A.F. AND R.F. TRIODE	4D	F	7.5	1.25	CLASS A AUDIO AMPLIFIER	250 350 425	-23.5 -32.0 -40.0	—	—	10 16 18	6000 5150 5000	1330 1550 1600	—	13000 11000 10 200	0.4 0.9 1.6	
						CLASS B AUDIO AMPLIFIER	250 350 425	-28.0 -40.0 -50.0	—	—	8.0 (6) 8.0 (6) 8.0 (6)	—	—	—	4000 6000 8000	13.0 (6) 20.0 (6) 25.0 (6)	
1603	NON-MICROPHONIC TRIPLE-GRID DETECTOR AMPLIFIER	8F	H	6.3	0.3	DETECTOR- AMPLIFIER	FOR OTHER CHARACTERISTICS, REFER TO TYPE 6J7										
1611	POWER AMPLIFIER PENTODE	7S	H	6.3	0.7	RELAY CONTROL TUBE	FOR CHARACTERISTICS, REFER TO TYPE 6F6										

TYPE	DESIGN	SOCKET CONN.	CATHODE TYPE AND RATING			USED AS	PLATE SUPPLY VOLTS	GRID BIAS VOLTS ②	SCREEN SUPPLY VOLTS	SCREEN CURRENT MILLIAMP.	PLATE CURRENT MILLIAMP.	A.C. PLATE RESISTANCE OHMS	TRANSCONDUCTANCE (GRID-PLATE) JUMHOS	AMPLIFICATION FACTOR	LOAD FOR STATED POWER OUTPUT OHMS	POWER OUTPUT WATT'S
			C.T.	VOLTS	AMP.											
1612	NON-MICROPHONIC PENTAGRID MIXER-AMPLIFIER	7T	H	6.3	0.3	MIXER OR CLASS A AMPLIFIER	FOR OTHER CHARACTERISTICS, REFER TO TYPE 6L7									
1620	NON-MICROPHONIC TRIPLE-GRID DETECTOR-AMPLIFIER	7R	H	6.3	0.3	AMPLIFIER	" " " " " " " 6J7									
1621	CONTINUOUS-SERVICE POWER AMPLIFIER PENTODE	7S	H	6.3	0.7	USED AS TRIODE ②③ PUSH-PULL CLASS A ₁ AMPLIFIER	327.5	500 Ω CATH. RESISTOR	—	—	55.0 ⑬	—	—	—	5000	2.0 ⑫
						USED AS PENTODE PUSH-PULL CLASS A ₁ AMPLIFIER	300	-30.0	300	8.5 ⑬	38.0 ⑬	—	—	—	4000	5.0 ⑫
1622	CONTINUOUS-SERVICE BEAM POWER AMPLIFIER	7AC	H	6.3	0.9	PUSH-PULL CLASS A ₁ AMPLIFIER	300	-20.0	250	4.0 ⑬	86.0 ⑬	—	—	—	4000	10.0 ⑫
2050	GAS TETRODE	2050-2051	H	6.3	0.6	GRID-CONTROLLED RECTIFIER	MAX. PEAK FORWARD ANODE VOLTAGE, 650 VOLTS. MAX. PEAK ANODE CURRENT, 500 MA. MAXIMUM AVERAGE ANODE CURRENT, 100 MA. SHIELD GRID (#2) VOLTAGE, 0 VOLTS. MAX. PEAK INVERSE ANODE VOLTAGE, 1300 VOLTS									
2051	GAS TETRODE	2050-2051	H	6.3	0.6	GRID-CONTROLLED RECTIFIER	MAX. PEAK FORWARD ANODE VOLTAGE, 350 VOLTS. MAX. PEAK ANODE CURRENT, 375 MA. MAXIMUM AVERAGE ANODE CURRENT, 75 MA. SHIELD GRID (#2) VOLTAGE, 0 VOLTS. MAX. PEAK INVERSE ANODE VOLTAGE, 700 VOLTS									

SOCKET CONNECTIONS
BOTTOM VIEWS

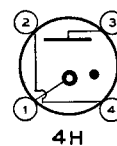
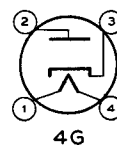
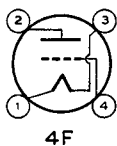
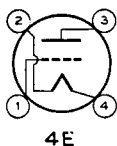
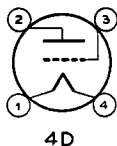
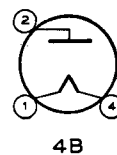
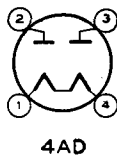
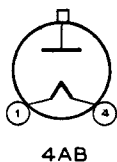
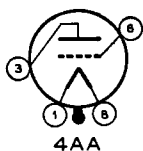

BOTTOM VIEWS

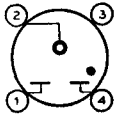

4J

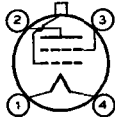

4K

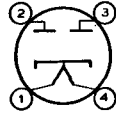

4L

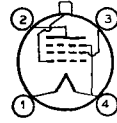

4M



4Q

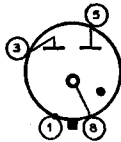

4R

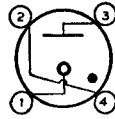

4S

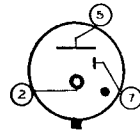

4V

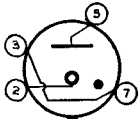

4W

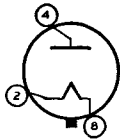

4X

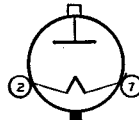

4Y

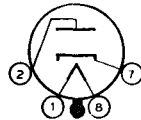

4Z

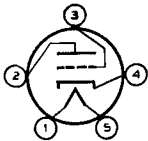

5A

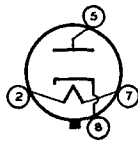

5AA

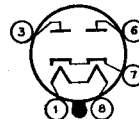

5AB

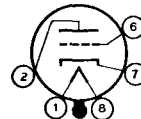

5AC

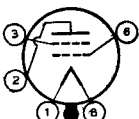

5AD

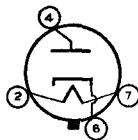

5AF

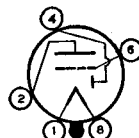

5AG

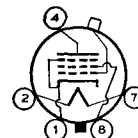

5AK

BOTTOM VIEWS

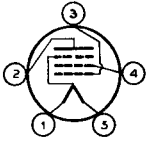

5B

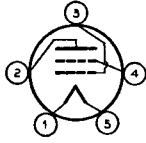

5C

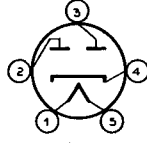

5D

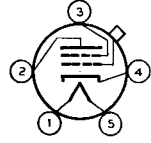

5E

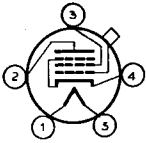

5F

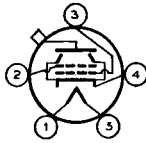

5G

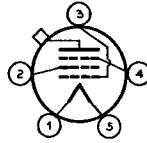

5J

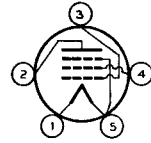

5K

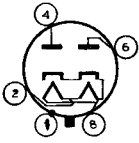

5L

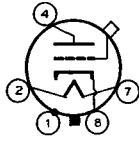

5M

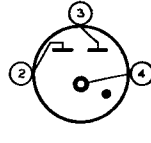

5N

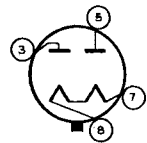

5Q

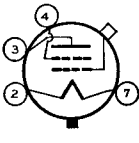

5R

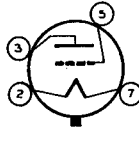

5S

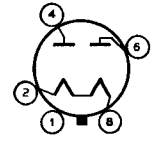

5T

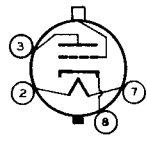

5U

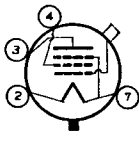

5Y

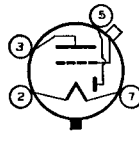

5Z

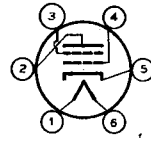

6A

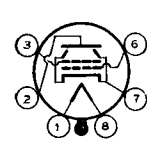

6AA

BOTTOM VIEWS

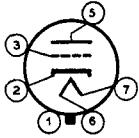

6AB

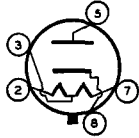

6AD

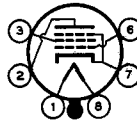

6AE

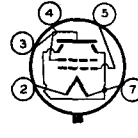

6AF



6AM

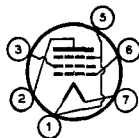

6AR

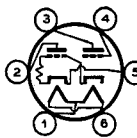

6AS

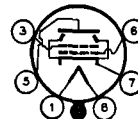

6AT

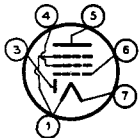

6AV

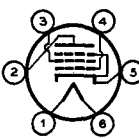

6B

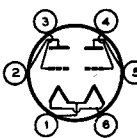

6C

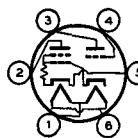

6D

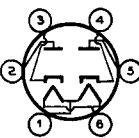

6E

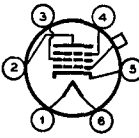

6F

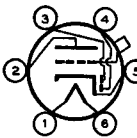

6G

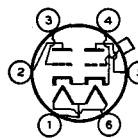

6H

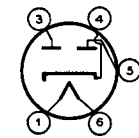

6J

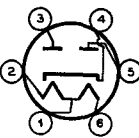

6K

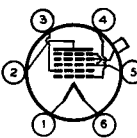

6L

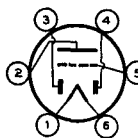

6M

BOTTOM VIEWS

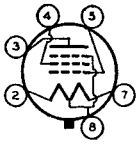

7AQ

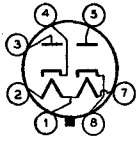

7AR

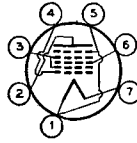

7AT



7AU

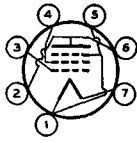

7AV

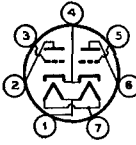

7B

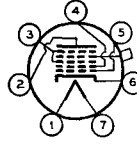

7C

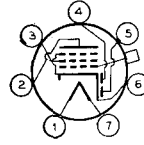

7D

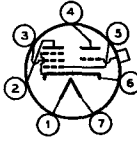

7E



7F

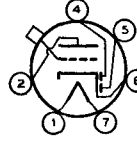

7G

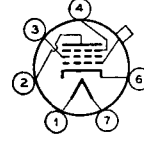

7H

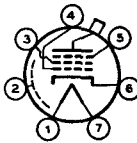

7J

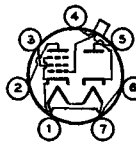

7K

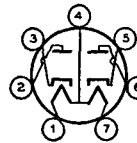

7L

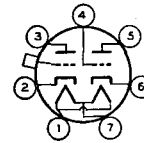

7M

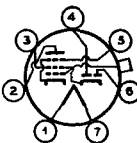

7N

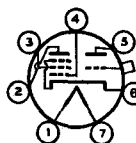

7P

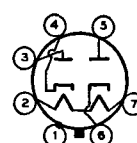

7Q

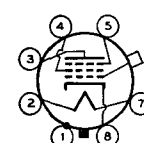

7R

BOTTOM VIEWS

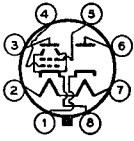

8AO

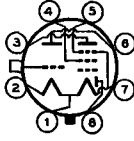

8AP

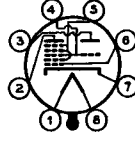

8AR

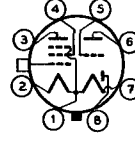

8AS

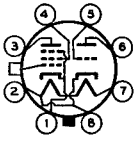

8AT

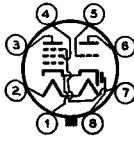

8AU

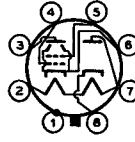

8AV

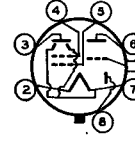

8AW

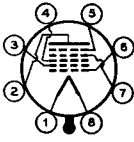

8AX



8AY

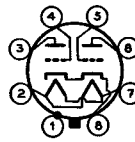

8B

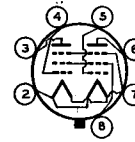

8C

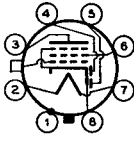

8E

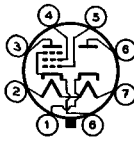

8F

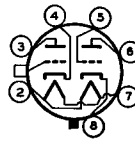

8G

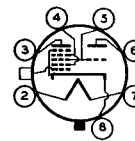

8H

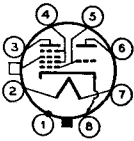

8K

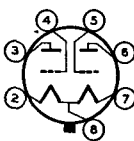

8L

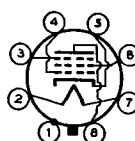

8N



8P

BOTTOM VIEWS

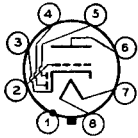

8Q



8R

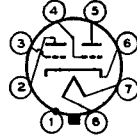

8S

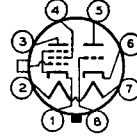

8T

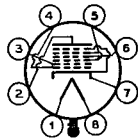

8U

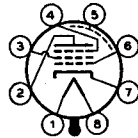

8V

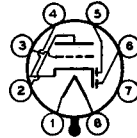

8W

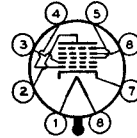

8X

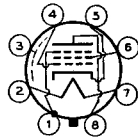

8Y

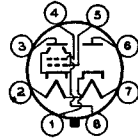

8Z

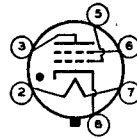

2050-
2051

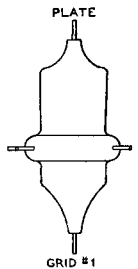

1

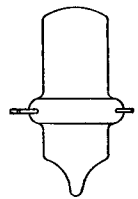

2

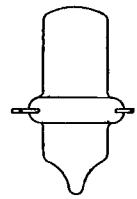

3

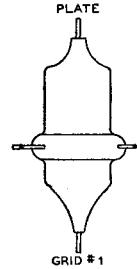

4

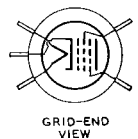

GRID-END
VIEW

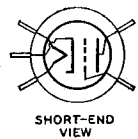

SHORT-END
VIEW

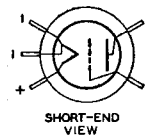

SHORT-END
VIEW

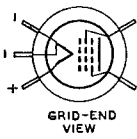

GRID-END
VIEW

FOOTNOTE REFERENCES FOR STANDARD AND SPECIAL RECEIVING TUBES

- ¹ For grid leak detection, plate volts 45, grid return to plus filament.
- ² Either a.c. or d.c. may be used on the filament or heater, except as specifically noted. For use of d.c. on filament types, decrease stated grid volts by $\frac{1}{2}$ of filament voltage.
- ³ Supply voltage applied through 20,000 ohm dropping resistor.
- ⁴ Mercury vapor type.
- ⁵ Grid no. 1 is control grid, grid no. 2 is screen, grid no. 3 is tied to cathode.
- ⁶ Grid no. 1 is control grid. Grids nos. 2 and 3 tied to plate.
- ⁷ Grids nos. 1 and 2 connected together, grid no. 3 connected to plate.
- ⁸ Grids nos. 3 and 5 are screen. Grid no. 4 is control grid (input).
- ⁹ Grids nos. 2 and 4 are screen. Grid no. 1 is control grid (input).
- ¹⁰ For grid of following tube.
- ¹¹ Both grids connected together; likewise both plates.
- ¹² Power output is for 2 tubes at stated plate to plate load.
- ¹³ For 2 tubes.
- ¹⁴ Preferably obtained by using 70,000 ohm dropping resistor in series with 90 volt supply.
- ¹⁵ Grids nos. 2 and 3 tied to plate.
- ¹⁶ Applied through plate resistor of 250,000 ohms or 500 hy. choke shunted by 250,000 ohm resistor.
- ¹⁷ Applied through plate resistor of 100,000 ohms.
- ¹⁸ Applied through plate resistor of 250,000 ohms.
- ¹⁹ 50,000 ohms.
- ²⁰ Requires different socket from small 7 pin.
- ²¹ Grid no. 2 tied to plate.
- ²² Plate voltages greater than 125 volts r.m.s. require 100 ohm (min.) series plate resistor.
- ²³ Applied through plate resistor of 150,000 ohms.
- ²⁴ For signal input control grid. Grid no. 3 bias, minus 3 volts.
- ²⁵ Applied through 200,000 ohm plate resistor.
- ²⁶ Grids nos. 2 and 4 are screen. Grid no. 3 is control grid.
- ²⁷ Maximum.
- ²⁸ Megohms.
- ²⁹ Grids nos. 1 and 2 tied together.
- ³⁰ Grids nos. 2 and 3 tied together.
- ³¹ Designed especially for hearing aid use.
- ³² "X" types have removable octal base.
- ³³ Operates into crystal earphone.
- ³⁴ Operates into magnetic reproducer.
- Subscript 1 on class of amplifier service indicates that grid current does not flow on any part of input cycle.
- Subscript 2 on class of amplifier service indicates that grid current flows on some part of input cycle.

CATHODE-RAY TUBES

OSCILLOSCOPE AND TELEVISION RECEIVING TYPES

TYPE	SOCKET CONN.	HEATER		DEFLEC- TION	SCREEN DIA. INCHES	USED AS	ANODE N° 1 VOLTS	ANODE N° 2 VOLTS	GRID N° 1 CUTOFF VOLTS	GRID N° 2 VOLTS	MAXIMUM PEAK VOLTS BETWEEN ANODE N°2 AND ANY DEF. PLATE	MAXIMUM SCREEN INPUT POWER PER SQUARE CENTIMETER MILLIWATTS	DEFLECTION SENSITIVITY MM./VOLT D.C.		GRID SIGNAL- SWING VOLTS	SCREEN ① MATERIAL	
		VOLTS	AMP.										D ₁ & D ₂	D ₃ & D ₄			
3AP1/906-P1	1	2.5	2.1	ELECTRO- STATIC	3	OSCILLOSCOPE	128 170 230 285 345 475	400 800 800 1000 1200 1500	APPROX. 20% OF ANODE N°1 VOLTAGE	—	600	10	0.81 0.55 0.41 0.33 0.27 0.22	0.87 0.58 0.44 0.35 0.29 0.23	—	P1	
3AP4/906-P4	1	2.5	2.1	ELECTRO- STATIC	3	PICTURE TUBE	FOR OTHER CHARACTERISTICS, REFER TO TYPE 3AP1/906 P1										P4
5AP4/1805-P4	2	6.3	0.6	ELECTRO- STATIC	5	PICTURE TUBE	430 575	1500 2000	-65 APPROX. -88 APPROX.	—	500	10	0.23 0.17	0.28 0.21	15 20	P4	
5BP1/1802-P1	2	6.3	0.8	ELECTRO- STATIC	5	OSCILLOSCOPE	250 310 425	1200 1500 2000	APPROX. 20% OF ANODE N°1 VOLTAGE	—	500	10	0.50 0.40 0.30	0.55 0.44 0.33	—	P1	
5BP4/1802-P4	2	6.3	0.8	ELECTRO- STATIC	5	PICTURE TUBE	FOR OTHER CHARACTERISTICS, REFER TO TYPE 5AP1/1802-P1										P4
7AP4	3	2.5	2.1	ELECTRO- MAGNETIC	7	PICTURE TUBE	675	3500	-67.5 APPROX.	—	—	2.5	—	—	15	P4	
9AP4/1804-P4	4	2.5	2.1	ELECTRO- MAGNETIC	9	PICTURE TUBE	1225 1425	8000 7000	-75 APPROX. -75 APPROX.	250 250	—	10	—	—	25 25	P4	
12AP4/1803-P4	4	2.5	2.1	ELECTRO- MAGNETIC	12	PICTURE TUBE	1240 1460	6000 7000	-75 APPROX. -75 APPROX.	250 250	—	10	—	—	25 25	P4	
902	5	8.3	0.6	ELECTRO- STATIC	2	OSCILLOSCOPE	100 150	400 600	-80 APPROX.	—	350	5	0.28 0.19	0.33 0.22	—	P4	
903	4	2.5	2.1	ELECTRO- MAGNETIC	9	OSCILLOSCOPE	195 580 900 1360	1000 2000 4600 7000	— — — -120 APPROX.	100 250 250 250	—	10	—	—	—	P1	
904	6	2.5	2.1	ELECTRO- STATIC— MAGNETIC	5	OSCILLOSCOPE	210 630 970	1000 3000 4600	— — -140 APPROX.	100 100 250	4000	10	0.40 0.13 0.09	—	—	P1	
905	7	2.5	2.1	ELECTRO- STATIC	5	OSCILLOSCOPE	225 450	1000 2000	-80 APPROX.	—	1000	10	0.38 0.19	0.46 0.23	—	P1	
907	7	2.5	2.1	ELECTRO- STATIC	5	OSCILLOSCOPE	FOR OTHER CHARACTERISTICS, REFER TO TYPE 905										P5
908	1	2.5	2.1	ELECTRO- STATIC	3	OSCILLOSCOPE	" " " " " " " 3AP1/906-P1										P5
909	7	2.5	2.1	ELECTRO- STATIC	5	OSCILLOSCOPE	" " " " " " " 905										P2
910	1	2.5	2.1	ELECTRO- STATIC	3	OSCILLOSCOPE	" " " " " " " 3AP1/906-P1										P2
911	1	2.5	2.1	ELECTRO- STATIC	3	OSCILLOSCOPE	FOR CHARACTERISTICS, REFER TO TYPE 3AP1/906-P1 ②										P2
912	8	2.5	2.1	ELECTRO- STATIC	5	OSCILLOSCOPE	1000 2000 3000	5000 10000 15000	— — -125 APPROX.	250 250 250	7000	10	0.083 0.041 0.028	0.102 0.051 0.034	—	P1	

913	5	6.3	0.6	ELECTRO-STATIC	1	OSCILLOSCOPE	50 100	250 500	— -90	—	250	5	0.15 0.07	0.21 0.10	—	P1
914	9	2.5	2.1	ELECTRO-STATIC	9	OSCILLOSCOPE	460 915 1500	2500 5000 7000	-100 APPROX. -100 APPROX. -100 APPROX.	250 250 250	3000	10	0.204 0.102 0.073	0.260 0.130 0.093	—	P1
1800	4	2.5	2.1	ELECTRO-MAGNETIC	9	PICTURE TUBE	625 925 1250	3000 4500 6000	— — -75 APPROX.	200 250 250	—	10	—	—	20 25 25	P3
1801	10	2.5	2.1	ELECTRO-MAGNETIC	5	PICTURE TUBE	375 450	2500 3000	— -35 APPROX.	—	—	10	—	—	15 20	P3

CATHODE-RAY TRANSMITTING TYPES

TYPE	USED AS	SOCKET CONN.	HEATER		ANODE N° 1	ANODE N° 2	GRID N°1 CUT-OFF VOLTS	GRID N°2 VOLTS	COLLECTOR		AVERAGE D.C. DEF. PLATE VOLTS	ROTATOR ELECTRODE VOLTS	MASK ELECTRODE VOLTS	DEFLECTING FLUX DENSITY GAUSSSES	FOCUSING DENSITY GAUSSSES	PEAK-TO-PEAK DEFLECTING VOLTAGE		TYPE OF PICKUP
			VOLTS	AMP.					VOLTS	UJAMPS.						HORIZONTAL	VERTICAL	
1840	ORTHICON	11	6.3	0.6	250	—	-40 APPROX.	225	—	—	225	100 APPROX.	-3	25 APPROX.	70 APPROX.	160	—	DIRECT OR FILM
1847	ICONOSCOPE	12	6.3	0.6	150	600 ③	-120 APPROX.	600 ③	600 ③	—	—	—	—	—	—	200	225	DIRECT
1848	ICONOSCOPE	13	6.3	0.6	300 APPROX.	1000 ④	-50 APPROX.	1000	1000 ④	0.1	—	—	—	—	—	—	—	DIRECT
1849	ICONOSCOPE	14	8.3	0.6	380	1000	-30 APPROX.	—	1000	0.05 TO 0.1	—	—	—	—	—	—	—	FILM
1850	ICONOSCOPE	14	6.3	0.6	FOR OTHER CHARACTERISTICS, REFER TO TYPE 1649												DIRECT	
1898	MONOSCOPE	15	2.5	2.1	240 300 360	600 1000 1200	-50 APPROX. -60 APPROX. -70 APPROX.	PATTERN ELECTRODE VOLTAGE			750 950 1150	BEAM CURRENT (UJAMP.)			1 A APPROX. 2 A APPROX. 3 A APPROX.	135 170 200	125 155 165	TEST PATTERN
1899	MONOSCOPE	16	2.5	2.1	260 390	1000 1500	— -80	—	1050 1700	—	PATTERN ELECTRODE VOLTAGE			1000 1500	BEAM CURRENT (UJAMP.)		2 4	TEST PATTERN

REFERENCES

¹ Screen materials are classified as follows: Phosphor no. 1 is of medium persistence and produces green fluorescence. Phosphor no. 2 is of long persistence and produces bluish-white fluorescence. Phosphor no. 3 is of medium persistence and produces yellow fluorescence. Phosphor no. 4 is of medium persistence and produces white fluorescence. Phosphor no. 5 is of short persistence and produces bluish fluorescence.

² The electron gun of the 907 is designed to be unusually free from magnetization effects.

³ Collector, grid no. 2 and anode no. 2 are connected together within the tube.

⁴ Collector and anode no. 2 are connected together within the tube.

CATHODE RAY TUBE SOCKET CONNECTIONS BOTTOM VIEWS

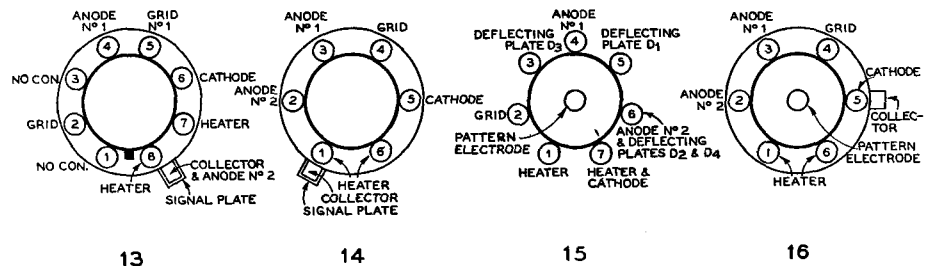
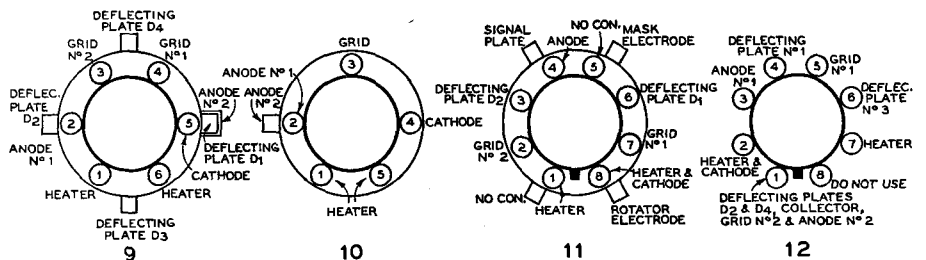
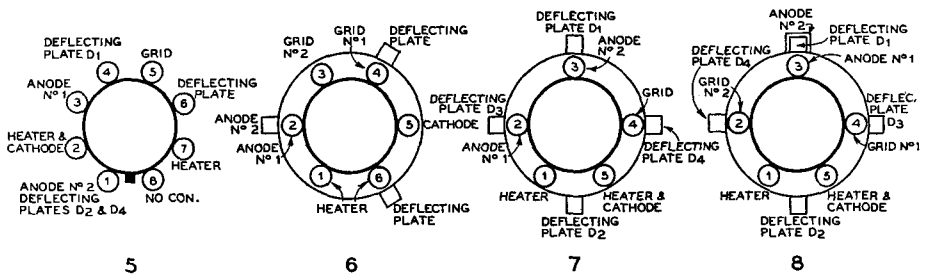
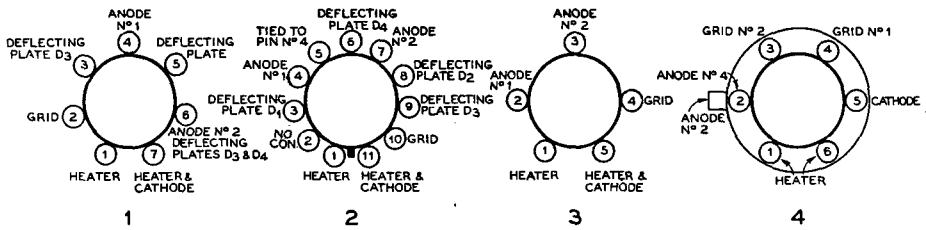

CHAPTER SIX

Radio Receiver Construction

The receivers described in this chapter can, for the most part, be constructed with a few inexpensive hand tools. Whether one saves anything over purchasing a factory built receiver depends upon several factors (see *chapter 19*). In any event, there is the satisfaction of constructing one's own equipment, and the practical experience that can be gained only by actually building apparatus.

After finishing the wiring job it is suggested that one go over the wiring very carefully to check for errors before applying plate voltage to the receiver. If possible, have someone else check the wiring after you have gone over it yourself. Some tubes can be damaged permanently by having screen voltage applied when there is no voltage on the plate. Electrolytic condensers can be damaged permanently by hooking them up backwards (wrong polarity). Transformer, choke, and coil windings can be burned out by incorrect wiring of the high voltage leads. Most any tube can be damaged by hooking up the elements incorrectly; no tube can last long with plate voltage applied to the control grid.

Before starting construction it is suggested that one read the chapter on *Workshop Practice*.

SIMPLE TWO-TUBE AUTODYNE

A simple yet versatile receiver of modest cost is illustrated in figures 1, 2, and 3. The receiver uses an autodyne detector and one stage of impedance coupled a.f. to give good earphone volume on all signals. The circuit is quite simple, as inspection of figure 4 will disclose.

The receiver uses 6.3-volt tubes, which may be supplied heater power from either a small 6.3-volt filament transformer or a regular 6-volt auto battery. For regular home use a transformer is recommended, but the provision for use with a battery permits

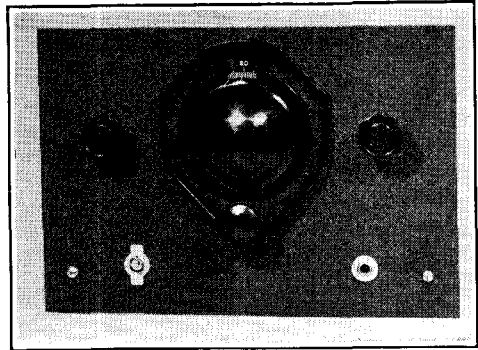

Figure 1.
SIMPLE TWO-TUBE AUTODYNE
RECEIVER.

This receiver is inexpensive to build and has excellent weak signal response. While not as selective as more elaborate receivers, it makes a good set for the newcomer's first receiver.

semi-portable operation. This makes the receiver a good one for a beginner, as it can be used as a portable or emergency receiver later on should one decide to build or buy a more elaborate receiver.

Plate voltage is supplied from a standard, medium-duty 45-volt B battery. Such a battery, costing only a little over a dollar, will last over a year with normal use, as the B current drain of the receiver is only a few milliamperes. This voltage is sufficient for good performance of the receiver, because the full plate voltage is supplied to the detector as a result of the use of a choke (CH.) instead of the usual plate resistor in the plate circuit of the detector. Also, the *amplification* of the 6C5 is practically as great at 45 volts as at the full maximum rated voltage of 250 volts. The maximum undistorted power output of the a.f. stage is considerably less at 45 volts, but as it is more than sufficient to drive a pair of phones, there is no point in using higher plate voltage. For these reasons a single B battery was de-

cided upon in preference to an a.c. power pack, because the battery is not only much less expensive but permits portable operation.

When wired as shown in the diagram, the receiver should not be used with higher plate voltage, because the screen potentiometer is across the full plate voltage, and also because the 1¼-volt bias on the 6C5 is not sufficient for higher plate voltage.

The receiver can be built for about \$12, including B battery and midget filament transformer, provided inexpensive components are chosen.

While the receiver will operate on 10 meters and a 10 meter coil is included in the coil table, the receiver is designed primarily for 20-, 40-, and 80-meter operation. No matter how well constructed, an autodyne receiver is not particularly effective on 10 meters, especially on phone. No provision was made for 160-meter operation, as the receiver does not have sufficient selectivity to distinguish between several very loud phone signals in the same part of the band.

For 20-, 40-, and 80-meter operation the receiver compares favorably with the most expensive when it comes to picking up weak, distant stations, especially on c.w. However, loud local signals have a tendency to block it, and therefore more trouble will be experienced with QRM than with a super-heterodyne.

The chassis consists of a 6x9 inch Masonite "presdwood" top and 1¾-inch back of

COIL TABLE For Two-Tube Autodyne

All coils wound with no. 22. d.c.c. on standard 1½-inch forms

	80 M.
29 turns close wound; cathode tap 1½ turns from ground	
	40 M.
16 turns spaced 1¾ inches; cathode tap 1½ turns from ground	
	20 M.
7 turns spaced 1¼ inches; cathode tap 1½ turns from ground	
	10 M.
4 turns spaced 1¼ inches; cathode tap 1 turn from ground	

the same material. These are fastened to two pieces of wood which form the sides of the chassis. The wooden sides are 1¾ inch high, ¾ inch thick, and are 6 inches long, including the Masonite back. The whole thing is held together with wood screws as may be seen in figures 2 and 4, and a 7-inch by 11-inch metal front panel is attached to the chassis by means of wood screws sunk in the wooden end pieces of the chassis.

Inexpensive wafer sockets are used. Because the thickness of the chassis would make it necessary to drill holes large enough to take the whole tube base if the sockets were mounted below the chassis as is customary



Figure 2.
BACK VIEW OF THE TWO-TUBE AUTODYNE.

The chassis is made of wood and Masonite wall board. The "shield hat" for the grid leak and condenser hide most of the main tuning condenser.

Figure 3.

UNDER-CHASSIS VIEW OF TWO-TUBE AUTODYNE.

The construction of the chassis and placement of components is clearly illustrated. If desired the phone jack may be mounted on the back of the chassis.

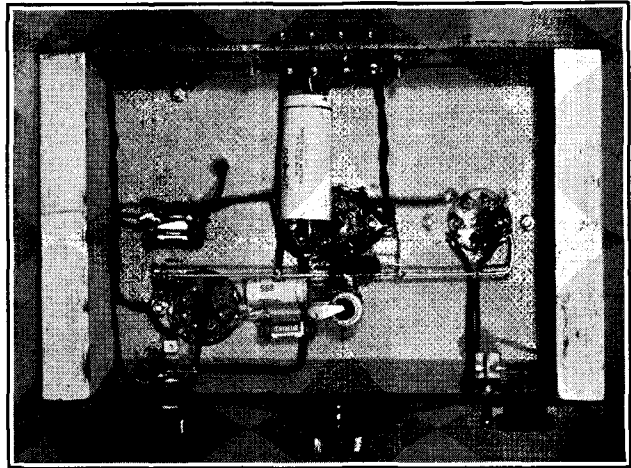

with metal chassis, the sockets are mounted on top of the chassis. This is clearly illustrated in the photographs.

Correct connection of the socket terminals can be assured by referring to the socket connections for the 6J7 and 6C5 in Chapter 5. Bear in mind that these are bottom views of the sockets, with the socket facing you the same as when soldering to the terminals from the underside of the chassis.

Connections for filament and plate power are made by means of a terminal strip which is mounted over a hole cut in the back of

the chassis. If you do not have the proper tools for cutting out a long, rectangular hole, four separate holes about 3/8 inch in diameter will take the terminal screws and lugs. If desired, the terminal strip can be replaced by four Fahnestock clips screwed directly to the back of the chassis.

The phone jack is shown mounted on the front panel, along with a toggle switch in the B plus lead. If mounted on the metal front panel, the phone jack must be insulated from the panel by means of fiber washers to prevent shorting the plate voltage. The jack

Figure 4.

WIRING DIAGRAM OF TWO-TUBE AUTODYNE.

By substituting a 6S7 for the 6J7 and a 6L5-G for the 6C5, the receiver can be run economically from dry cells for heater power. Only 4 1/2 volts is required, and three no. 6 dry cells will give over 150 hours life.

- C₁—15- μ fd. midget variable
- C₂—100- μ fd. midget variable
- C₃—100- μ fd. smallest size mica condenser
- C₄—0.25- μ fd. tubular, 400 v.
- C₅—0.0005- μ fd. midget mica
- C₆—0.01- μ fd. tubular, 400 v.
- R₁—3 meg., 1/2 watt
- R₂—50,000 ohm pot.
- R₃—0.25 meg., 1/2 watt
- R₄—0.5 meg., 1/2 watt
- BC—1 1/4-volt bias cell
- CH—300 or more hy., 5 ma.
- L₁—See coil table

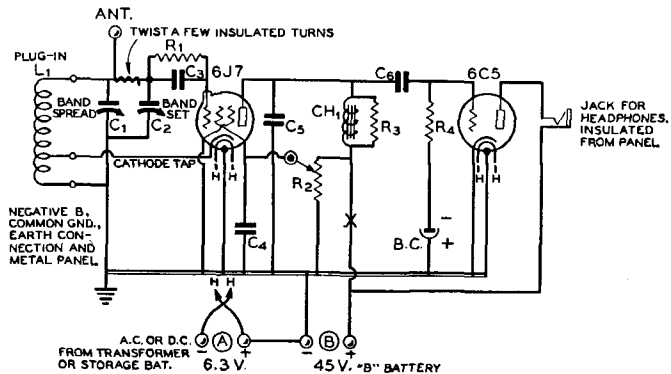

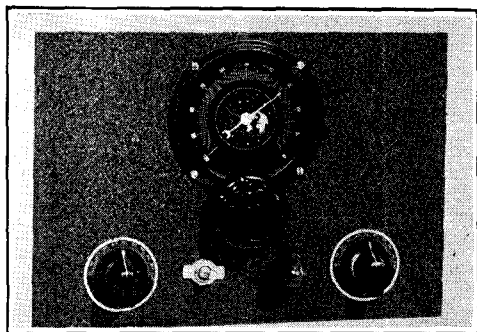

Figure 5.
SIMPLE THREE-TUBE SUPERHETERO-
DYNE.

The bandset condenser is to the left, the detector "resonating" condenser to the right. The latter makes an effective volume control. The small knob operates the regeneration potentiometer.

could just as well be mounted on the back of the chassis, in which case it would not require insulating washers.

The screen potentiometer is across the B battery and draws a small amount of current even with the filaments turned off; hence it is necessary either to unhook the B battery when the set is not in use or else incorporate a switch to accomplish the same thing. If desired a potentiometer with an "off switch" can be used, in which case the potentiometer knob all the way to the left. The heaters are turned off by turning off the 110-volt supply to the filament transformer.

As is true with any grid leak type detector, the grid lead (including the grid leak and condenser) must be shielded thoroughly in order to avoid bad hum pickup, commonly known as "grid hum." This is accomplished effectively by soldering the grid leak and grid condenser (both of the smallest physical size procurable) directly to the grid clip and shielding the whole business by means of a "hat" consisting of a regular metal tube grid shield cap to which is soldered a rectangular piece of tin or galvanized iron as shown in the illustration. The latter measures about $1\frac{1}{2}$ by 3 inches and is bent in the form of a "U," then soldered to the grid clip shield. Care must be taken that the shield does not short out against any of the connecting leads.

The antenna may consist of a 50 to 100 foot length of wire as high and in clear as possible. It is capacity coupled to the receiver by means of a few turns of insulated wire around the grid lead. A small 3-30 μ fd.

compression type mica trimmer may be substituted as a variable coupling condenser if desired.

After the correct position of the bandset condenser (C_2) is determined for a given band, a scratch or mark is made on the back rotor plate to enable one to adjust the bandset condenser for any band simply by observing the marks on the bandset condenser.

The wiring diagram assumes that the receiver will be used with magnetic type earphones. If crystal earphones are used, a small 30-hy. choke should be connected across the headphone jack.

SIMPLE THREE-TUBE SUPERHETERODYNE

The small superheterodyne shown in the accompanying illustrations has practically all of the advantages of sets having many more tubes. It has good image rejection, selectivity and sensitivity, and drives either phones or a dynamic loudspeaker to good volume.

A 6K8 converter directly feeds a regenerative second detector operating just above 1500 kc. The latter is impedance coupled to a beam tetrode audio tube. The plate current and audio power output are too great for a pair of phones; so the phones are connected in the screen circuit.

Excellent selectivity and sensitivity are obtained on phone by running up the regeneration on the second detector right to the edge of oscillation. By advancing the regeneration control still farther the second detector will oscillate, thus providing autodyne reception of code signals. The regeneration also acts as a sensitivity control to prevent blocking by very loud local signals. To keep loud phone signals from blocking, the regeneration is decreased way below the edge of oscillation. To keep loud c.w. signals from blocking, the regeneration control is advanced full on.

The 6K8 converter is conventional and no special precautions need be taken with this stage except to keep the first detector leads as short as possible in order to obtain maximum performance on 10 meters. A minimum number of coils is required for all-band operation (10 to 160 meters) because the oscillator coil for each band serves as the detector coil for the next higher frequency band, the tickler serving as the antenna winding. Thus all coils except the 160-meter detector and 10-meter oscillator coils do double duty.

The set is built on a metal chassis meas-

uring 2½ inches by 6 inches by 8 inches. This supports a 7-inch by 10-inch front panel. The correct placement of components may be determined by referring to the illustrations.

To obtain regeneration in the grid leak type second detector, a tickler coil is added to the i.f. transformer. Inspection of figure 7 will show that the second detector then resembles the common "autodyne" grid leak detector with regeneration control.

For maximum performance, the detector should go into oscillation when the screen voltage is about 35 volts. This is accomplished by using as a tickler 3 turns of no. 22 d.c.c. wound around the dowel of the i.f. transformer, right against the grid winding. Few tickler turns are required, as there is no antenna to load the detector, and therefore it goes into oscillation with but little feedback.

To wind the tickler, simply remove the shield from the i.f. transformer, and, using a foot length of the same d.c.c. used to wind the plug in coils, wrap three turns around the dowel as closely as possible to the grid winding. Then twist the two leads together to keep the turns in place and replace the shield. The polarity of the tickler must be correct for regeneration; if oscillation is not obtained, reverse the two tickler leads.

Care must be taken with the grid leak, grid condenser, and grid lead of the 6SJ7; other-

wise there will be "grid hum." The outside foil of the tubular grid condenser should go to the i.f. grid coil and *not* to the grid of the tube. Connection to the grid pin of the 6SJ7 socket should be kept as short as possible—not over a half inch, and both grid leak and grid condenser should be kept at least a half inch from other wiring. In some cases it may be necessary to shield the grid leak and condenser with a small piece of grounded tin in order to eliminate grid hum completely.

The phone jack is a special type, commonly called a two-circuit "filament lighting" jack. It is connected so that when the phones are inserted they not only are connected in the screen circuit in such a way that no d.c. flows through the phones, but the speaker transformer is shorted out in order to silence the speaker. Switching the plate of the 6V6 directly to B plus also improves the quality in the phones slightly.

Any well-filtered power supply delivering between 300 and 375 volts at 50 ma. can be used to supply the receiver. If the speaker is of the p.m. type, requiring no field supply, a 200 to 250 volt power pack will suffice.

Either a two-wire feeder or single-wire antenna worked against ground can be used. For doublet input, connect to the two antenna coil terminals. For Marconi input, ground one terminal and connect the antenna to the other.

Figure 6.
REAR VIEW OF THE SIMPLE
SUPER.

The detector coil is to the left, directly above the detector tuning condenser, and the oscillator coil is to the right. Antenna terminals, power socket, speaker plug socket, and earphone jack may be seen on the back drop of the chassis.

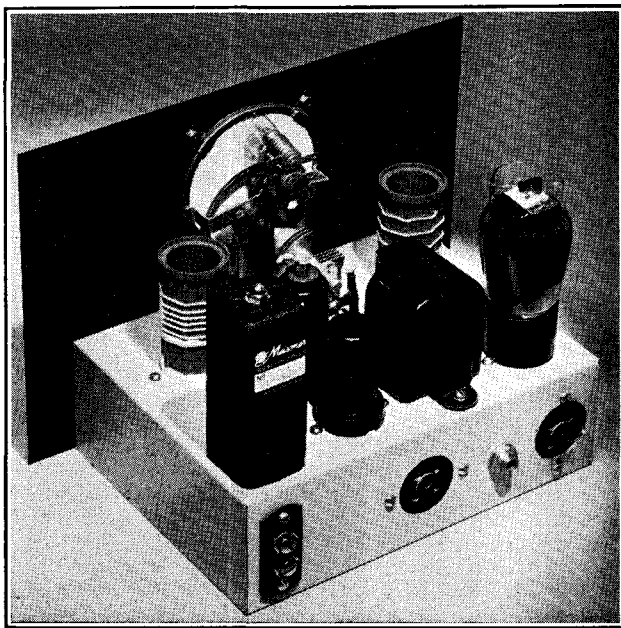
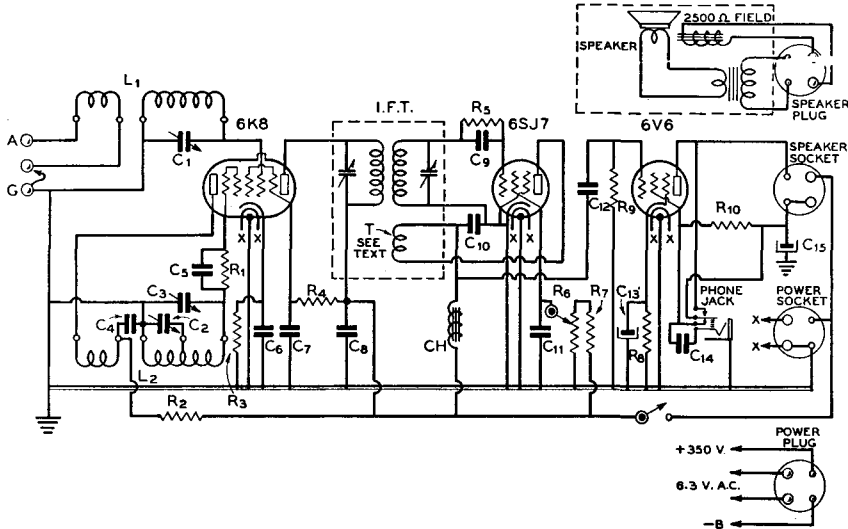

Figure 7.
WIRING DIAGRAM OF THE SIMPLE SUPER.



C₁, C₂—50- μ fd. midget variable
 C₃—140- μ fd. midget variable
 C₄, C₈, C₁₁, C₁₄—0.1- μ fd. tubular, 400 v.
 C₅, C₉—0.001- μ fd. tubular, 600 v.
 C₆, C₇, C₁₂—0.01- μ fd. tubular, 600 v.

C₁₀—0.01- μ fd. tubular, 600 v.
 C₁₃—25- μ fd. 25 v. electrolytic
 C₁₅—4- μ fd. 450 v. tubular electrolytic
 R₁, R₂—50,000 ohms, 1 $\frac{1}{2}$ watts
 R₃—300 ohms, 1 watt
 R₄—40,000 ohms, 1 $\frac{1}{2}$ watt

R₅—5 meg. insulated $\frac{1}{2}$ watt resistor
 R₆—100,000 ohm potentiometer
 R₇—100,000 ohms, 1 $\frac{1}{2}$ watts
 R₈—400 ohms, 10 watts
 R₉—500,000 ohms, 1 $\frac{1}{2}$ watts
 R₁₀—10,000 ohms, 10 watts

IFT—1500 kc. replacement type i.f. trans. (see text for tickler data)
 CH—High impedance audio choke, 500 or more hy.
 Phone Jack—Two circuit "filament lighting" type

Adjusting the mica trimmer on the grid coil of the i.f.t. changes the i.f. frequency. The trimmer on the plate coil should always be resonated for maximum signal strength. It need not be touched after the initial adjustment unless the grid trimmer is changed. The i.f. frequency should be adjusted to about 1550 kc. and then a check made to make sure it is not right on some nearby police or high fidelity broadcast station.

The only band on which images might be bothersome is the 10-meter band. In most cases objectionable images can be eliminated without serious loss in signal strength by shifting the h.f. oscillator to the other side by means of the bandset condenser. The receiver will work with the oscillator either *higher or lower* by the i.f. frequency than the received signal. On the higher frequency bands the bandset condenser tunes over a wide enough band of frequencies that it hits both sides.

On certain bands the gain and sensitivity are better with the h.f. oscillator on one side of the detector than on the other. Some experimenting with the bandset condenser should be made on those bands where it is possible to hit both the high and low side with the bandset condenser.

ECONOMICAL FIVE-TUBE SUPERHETERODYNE

The sensitivity of the simple superheterodyne just described can be increased by the addition of a tuned r.f. stage ahead of the mixer. The gain and selectivity can be increased by the addition of an i.f. stage. These additions do not add greatly to the total cost and the improvement in performance makes their incorporation highly desirable. The construction, however, is somewhat more difficult, and should not be attempted as the builder's first effort.

Figure 8.
UNDER-CHASSIS VIEW OF
SIMPLE SUPER.

Not much room to spare, but all components fit without crowding. The phone jack is mounted directly on the rear drop of the metal chassis; because of the method of connection, no insulating washers are required.

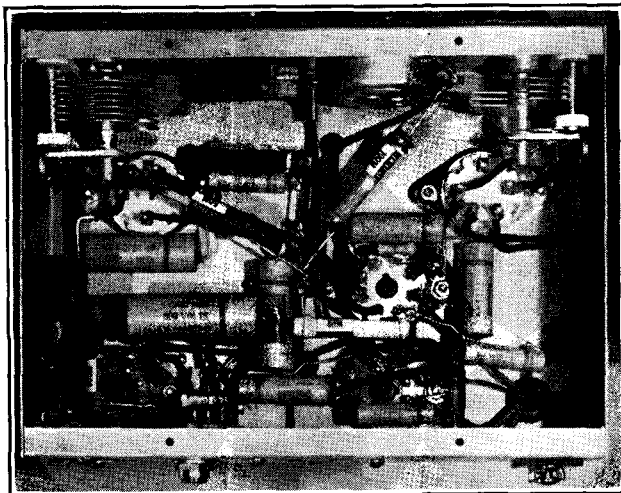

Electrically the receiver is essentially the same as the three-tube superheterodyne except for the addition of a 6K7 radio frequency stage and a 6SK7 intermediate frequency amplifier. To minimize the number of tuning controls, the tank condenser for the r.f. stage is ganged with the tank condenser of the mixer stage.

Mechanical Layout. The r.f. stage is located on the left front corner of the 7x11x2 inch chassis. The mixer stage is placed at the rear left corner of the chassis, with the shield partition visible in figure 9 separating it from the r.f. stage. Placing the r.f. and mixer coils toward the edge of the chassis removes them from the proximity of the front-to-back shield, which otherwise might lower the gain obtained in the tuned circuits.

The under-chassis view, figure 11, shows the location of the two 50- $\mu\mu\text{fd}$. ganged condensers used to tune the r.f. and mixer stages. By reversing the usual mounting procedure on these condensers and hanging them stator side down from the chassis, the shafts are brought out at the center of the front drop. A small isolantite coupling is used to gang the two condensers.

For data on how to wind the tickler turns on the second i.f. transformer, refer to the description given for the three-tube superheterodyne previously described. The procedure is the same for either receiver. The remarks pertaining to grid hum in the second detector also apply to the five tube model.

The receiver is designed for enclosure in a metal cabinet. The cabinet completes the shielding between the r.f. and mixer stages,

COIL TABLE
For Simple Super

160-M. Det.

58 turns no. 24 enam. close wound on $1\frac{1}{2}$ in. form, padded with 50 $\mu\mu\text{fd}$. midget mica fixed condenser placed inside form. Ant. coil 14 turns close wound at ground end spaced $\frac{1}{4}$ in. from grid winding.

160-M. Osc.—80-M. Det.

42 turns no. 22 d.c.c. close wound on $1\frac{1}{2}$ in. form. Bandsread tap 20 turns from ground end. Tickler 9 turns close wound, spaced $\frac{1}{16}$ in. from main winding.

80-M. Osc.—40-M. Det.

20 turns no. 22 d.c.c. spaced to $1\frac{1}{2}$ in. on $1\frac{1}{2}$ in. form. Bandsread tap 12 turns from ground end. Tickler 8 turns close wound, spaced $\frac{1}{8}$ in. from main winding.

40-M. Osc.—20-M. Det.

11 turns no. 22 d.c.c. spaced to $1\frac{1}{4}$ in. on $1\frac{1}{2}$ in. form. Bandsread tap 5 turns from ground end. Tickler 6 turns close wound, spaced $\frac{1}{8}$ in. from main winding.

20-M. Osc.—10-M. Det.

$5\frac{1}{2}$ turns no. 22 d.c.c. spaced to 1 in. on $1\frac{1}{4}$ in. form. Bandsread tap 3 turns from ground end. Tickler 4 turns close wound, spaced $\frac{1}{16}$ in. from main winding.

10-M. Osc.

3 turns no. 22 d.c.c. spaced to 1 in. on $1\frac{1}{4}$ in. form. Bandsread tap $1\frac{1}{2}$ turns from ground end. Tickler 2 turns close wound, spaced $\frac{1}{16}$ in. from main winding.

Tickler is always at ground end of main coil. Note that two highest frequency coils are on $1\frac{1}{4}$ in. forms, rest $1\frac{1}{2}$ in. Tickler polarity must be correct or mixer will not oscillate.

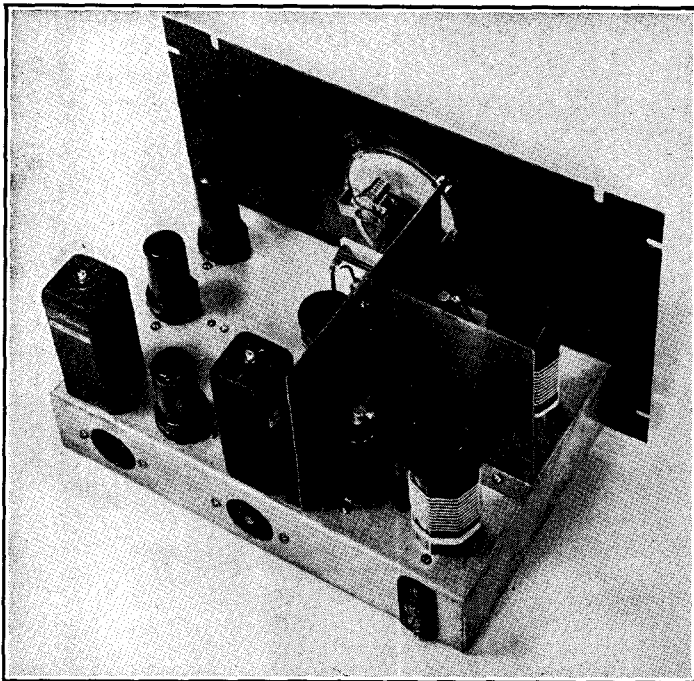

Figure 9.
TOP VIEW OF 5-TUBE
SUPERHET.

R.f. stage at the front, mixer at the rear and the i.f. and audio strung out along the rear and far edge of the chassis. A corner of the oscillator coil may be seen peeking around the front-to-rear shield.

and prevents oscillation. If a metal cabinet is not used, more elaborate shielding partitions than those illustrated in figure 9 will be required.

Coils. If the data given in the coil table are followed closely no trouble should be experienced in getting the r.f. and mixer stages to track accurately. It will be noted that the r.f. and mixer coil secondaries are identical on all bands except 10 meters, where the r.f.

stage has one less turn. It is a simple matter to check the tracking. All that is necessary is to loosen the set screws on the coupling between the r.f. and mixer condensers and resonate each condenser separately. By observing the amount of capacity used to resonate each stage near the center of the band in question, it may be determined whether an increase or decrease in the inductance of either coil is necessary.

COIL TABLE

Band	L ₁	L ₂	L ₃
80	Grid—42 turns closewound Antenna—7 turns closewound Form—1½" dia.	Grid—42 turns closewound Plate—9 turns closewound Form—1½" dia.	Grid—20 turns spaced to 1½" Tickler—8 turns closewound Tap—15 t. from ground end Form—1½" dia.
40	Grid—21 turns spaced to 1½" Antenna—6 turns closewound Form—1½" dia.	Grid—21 turns spaced to 1½" Plate—7 turns closewound Form—1½" dia.	Grid—10 turns spaced to 1¼" Tickler—6 turns closewound Tap—6½ t. from ground end Form—1½" dia.
20	Grid—11 turns spaced to 1¼" Antenna—4 turns closewound Form—1½" dia.	Grid—11 turns spaced to 1¼" Plate—6 turns closewound Form—1½" dia.	Grid—6 turns spaced to 1" Tickler—4 turns closewound Tap—4 t. from ground end Form—1¼" dia.
10	Grid—6 turns spaced to 1" Antenna—4 turns closewound Form—1¼" dia.	Grid—7 turns spaced to 1" Plate—4 turns closewound Form—1¼" dia.	Grid—3 turns spaced to 1" Tickler—3 turns closewound Tap—2 t. from ground end Form—1¼" dia.

All coils are wound with no. 22 d.c.c. wire

Figure 11.
SHOWING FRONT PANEL
AND UNDERSIDE OF CHAS-
SIS.

Most of the "works" are under the chassis. The two ganged r.f. and mixer tuning condensers are visible in this photograph, as is the oscillator bandsetting condenser.

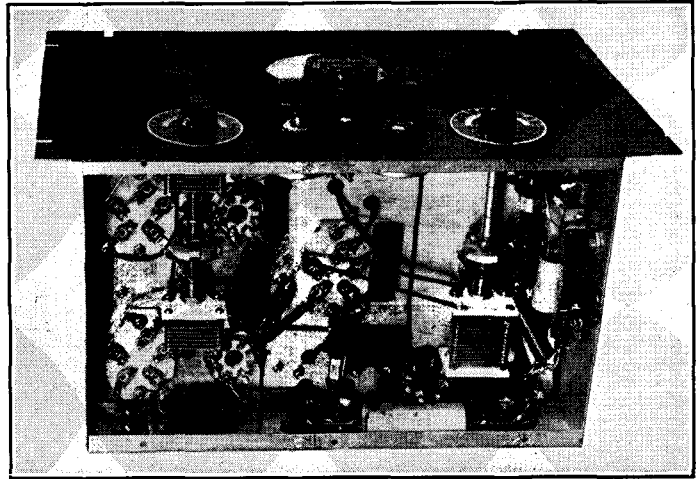
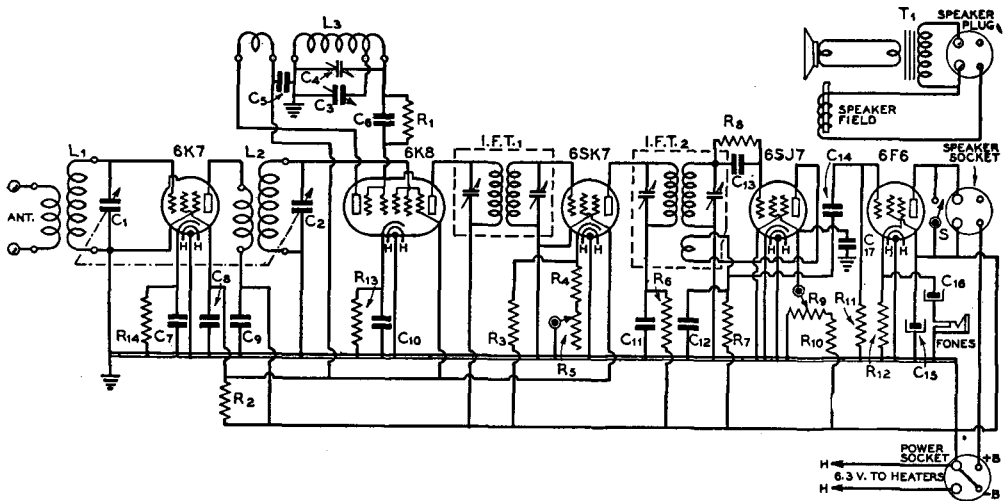

Figure 10.
GENERAL WIRING DIAGRAM OF THE FIVE-TUBE SUPER.



- C₁, C₂—50- μ fd. midget variable
- C₃—25- μ fd. midget variable
- C₄—140- μ fd. midget variable
- C₅—0.1- μ fd. 400-volt tubular
- C₆—0.001- μ fd. mica
- C₇—0.1- μ fd. 400-volt tubular
- C₈, C₉, C₁₀, C₁₁—0.1- μ fd. 400-volt tubular
- C₁₂—0.005- μ fd. mica
- C₁₃—0.001- μ fd. mica

- C₁₄—0.1- μ fd. 400-volt tubular
 - C₁₅—8- μ fd. 450-volt electrolytic
 - C₁₆—10- μ fd. 25-volt electrolytic
 - C₁₇—0.1- μ fd. 400-volt tubular
- Note: Omitted from the diagram was a condenser from the 6SK7 i.f. stage cathode to ground. This condenser should be a .01- μ fd. 400-volt unit.

- R₁—75,000 ohms, 1/2 watt
- R₂—25,000 ohms, 2 watts
- R₃—60,000 ohms, 1 watt
- R₄—300 ohms from stop on R₆
- R₅—10,000-ohm potentiometer
- R₆—2000 ohms, 1/2 watt
- R₇—250,000 ohms, 1/2 watt
- R₈—1 megohm, 1/2 watt
- R₉—10,000-ohm potentiometer
- R₁₀—100,000 ohms, 1 watt

- R₁₁—250,000 ohms, 1/2 watt
- R₁₂—600 ohms, 10 watts
- R₁₃, R₁₄—300 ohms, 1/2 watt
- I.F.T.₁—1500-kc. input i.f. transformer
- I.F.T.₂—1500-kc. input i.f. transformer (see text for alterations)
- S—S.p.s.t. toggle switch
- L₁, L₂, L₃—See coil table
- T₁—Pentode output transformer (on speaker chassis)

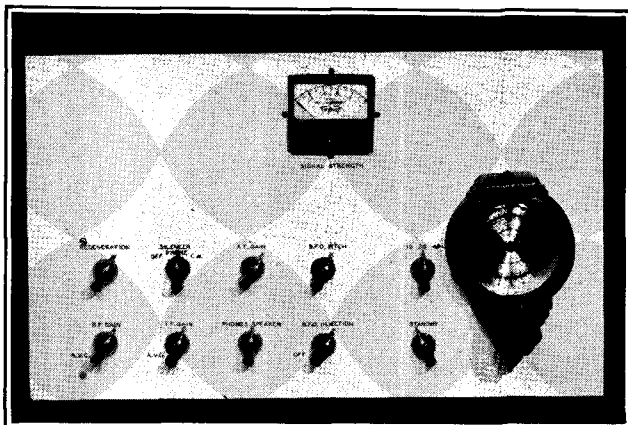

Figure 12.
FRONT PANEL VIEW OF THE AD-
VANCED SUPERHETERODYNE.

Maximum operating flexibility is provided by having all controls on the panel. In the top row the controls are, from left to right: regeneration, noise limiter, a.f. gain, b.f.o. pitch, and bandswitch; bottom row: r.f. gain, i.f. gain, phones-speaker switch, b.f.o. injection, and standby switch.

The oscillator bandspread tap location given in the coil table will give nearly full-dial coverage of each band. Individual constructors who may have different ideas as to the proper amount of bandspread to use may move the taps along the coils to obtain any desired amount. The 20- or 75-meter phone bands may be spread across the whole dial, for instance, by moving the taps on the coils for these bands nearer the grounded end. Conversely, any one of the bands may be packed into a few dial divisions by moving the coil tap on that band to the grid end of the coil.

Initial Operation. After the receiver has been connected to a power supply delivering from 250 to 300 volts and a speaker having a field resistance of 1500 to 2500 ohms, the i.f. stage and second detector input circuit should be aligned. This is best accomplished with the aid of a signal generator operating in the 1500-to-1600 kc. range coupled loosely to the grid of the mixer. The detector should go into oscillation very smoothly when the regeneration control, R_0 , is advanced. If oscillation does not take place it is probable that the tickler is improperly phased, and the tickler connections should be reversed.

After the i.f. amplifier has been aligned, a set of coils should be plugged in and the oscillator bandsetting condenser set to the proper capacity for the coils in use. With a 0-100 scale, with zero at the low capacity end, this setting will be as follows: 10 meters, 35; 20 meters, 80; 40 meters, 60; 80 meters, 60. Next, the r.f. and mixer tuning control should be brought into resonance and, after the oscillator bandsetting control has been adjusted to center the band on the dial, the receiver is ready for use.

ADVANCED BANDSWITCHING PHONE AND C. W. RECEIVER

Quite often receivers are designated as either "phone" or "c.w." sets. This is a desirable designation because the receivers in question have been designed for peak performance in one type of operation and the other use becomes of secondary importance in their circuit arrangement. However, it is quite possible to design a receiver for peak performance for both phone and c.w. Such a receiver is pictured in figures 12-15. This receiver should appeal to the advanced constructor who has had previous experience in receiver construction.

After adequate sensitivity has been provided by a well-designed "front end," two widely differing characteristics in i.f. selectivity must be included to give a universal phone-c.w. receiver. These are: (1) a square-topped selectivity with narrow "skirts" for phone reception and (2) sharply peaked selectivity for single-signal c.w. reception. These two characteristics are provided in this receiver along with such other features as bandswitching, noise limiter, optional a.v.c. or manual gain control on either the i.f. or r.f. stages, b.f.o. injection control, and double conversion for the elimination of images.

Bandswitching. Bandswitching is seldom employed in home-constructed receivers because well-designed coil and switch assemblies are rather costly. By limiting the switching to three bands, however, the cost of the coil and switch assembly may be made little more than that of a set of plug-in coils. Three 3-pole, 3-position isolantite selector switches are used. As may be seen from the circuit diagram, each of these switches per-

Figure 13.
SHOWING THE CHASSIS LAY-
OUT OF THE ADVANCED SU-
PER.

From the rear, the location of the various components above the chassis is clearly visible. The three large shield cans at the left edge of the chassis cover the plug-in coils which are used for the 40- and 80-meter bands.

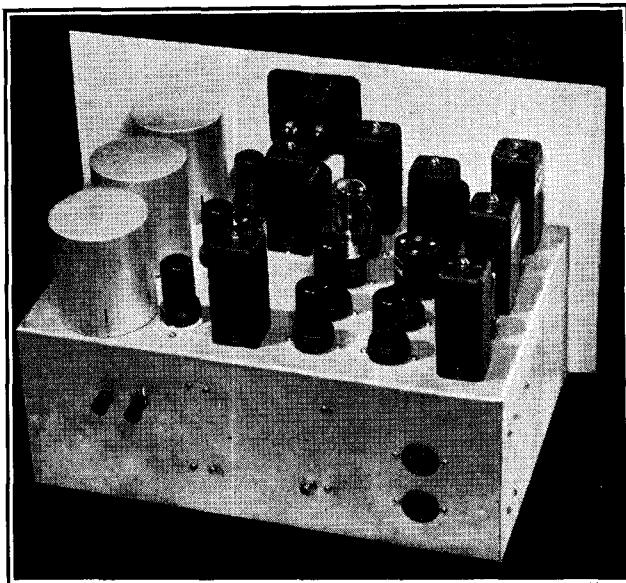

forms three switching operations for each band for each stage in the "front end." The 10- and 20-meter band coils are air-supported and mounted under the 6-inch-deep chassis close to their respective switch sections. For the third band, which may be either 40 or 80 meters, a set of 5-prong sockets under the shield cans at the right edge of the chassis is switched into the circuit. Thus three bands are made available at the flip of a switch and a fourth band can be had through the use of plug-in coils.

Circuit Arrangement. To eliminate images on the higher-frequency bands and at the same time allow a high degree of selectivity, the i.f. channel employs double conversion. That is, signals are first converted to a relatively high frequency (1500 kc.) and amplified and then again converted, this time to a relatively low frequency (175 kc.) and further amplified. High selectivity is made available, when desired, through the use of optional regeneration in the 175-kc. stage. The square-topped, bandpass characteristic so necessary for phone reception is effected by negative-mutual coupling coils in the 1500-kc. i.f. amplifier.

Tube Lineup. An 1853 tube is used in the r.f. amplifier stage. This stage, as well as all the others in the receiver except the 6J5 first audio stage, receives fixed bias from the bias network, R_{34} , R_{35} . The r.f. gain potentiometer, R_{11} , varies the amount of this fixed bias from 3 to 20 volts. When the r.f. gain control is turned completely "off," the

switch S_2 is operated and the 1853 grid return is connected to the a.v.c. line. The cathode of detector-a.v.c. diode is returned to the -3 volt line so that the bias on either the manual or the a.v.c. positions never falls below 3 volts. The gain control circuit on the i.f. stages is a copy of that on the r.f. stage, with either a.v.c. or manual gain being applied to the grid returns of the first mixer, 1500-kc. i.f. amplifier and second mixer. The 175-kc. i.f. amplifier stage receives fixed bias directly from the -3 volt line, as either manual or automatic adjustment of gain in this stage would result in difficulty in attempting to set the regeneration control.

The 6SA7 first mixer stage is entirely conventional, with injection from the grid side of the oscillator tank circuit through a 50- μ fd. condenser, C_{14} . A 6J5 is used in the oscillator in a grounded-plate Hartley circuit. 150 volts of regulated voltage is applied to this stage from the VR-150-30 regulator tube.

Negative-Mutual Coils. The negative-mutual coupling coils in the 1500 kc. i.f. stage must be connected as shown in the diagram. These units have six turns on each winding, the coils being interwound on a $\frac{1}{2}$ -inch form. No. 22 d.c.c. wire is used. Following the 6SK7 1500-kc. stage is the 6SA7 second mixer. Some changes are necessary in the oscillator coil specified in the parts list and Buyer's Guide to make it suitable for use with the 6SA7. The coil must be

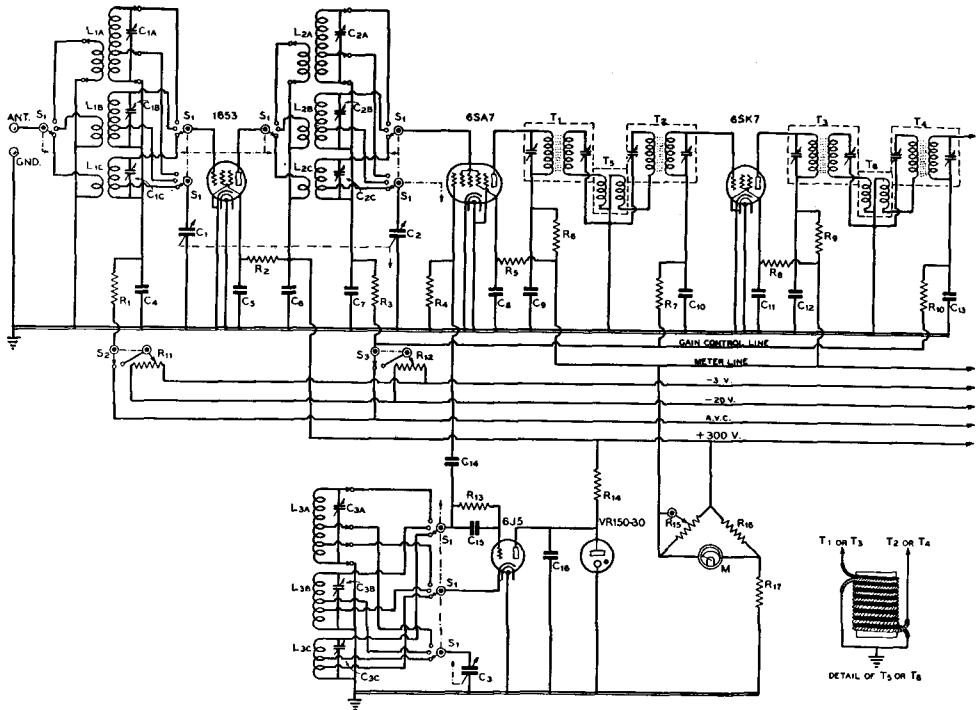

Figure 14.

SCHMATIC DIAGRAM OF THE ADVANCED SUPERHETERODYNE.

C ₁ , C ₂ , C ₃ —35- μ fd. midget variable	C ₁₆ —0.1- μ fd. 400-volt tubular	C ₂₉ , C ₃₀ —0.1- μ fd. 400-volt tubular	R ₁ —100,000 ohms, 1/2 watt
C ₄ , C ₅ , C ₆ , C ₇ —0.01- μ fd. midget mica	C ₁₇ —0.0001- μ fd. mica	C ₃₁ , C ₃₂ —25- μ fd. 25-volt electrolytic	R ₂ —40,000 ohms, 1/2 watt
C ₈ , C ₉ —0.1- μ fd. 400-volt tubular	C ₁₈ , C ₁₉ , C ₂₀ , C ₂₁ —0.1- μ fd. 400-volt tubular	C ₃₃ —0.0005- μ fd. mica	R ₃ —100,000 ohms, 1/2 watt
C ₁₀ —0.05- μ fd. 400-volt tubular	C ₂₂ —0.0001- μ fd. mica	C ₃₄ —15- μ fd. midget variable	R ₄ —100,000 ohms, 1/2 watt
C ₁₁ , C ₁₂ —0.1- μ fd. 400-volt tubular	C ₂₃ , C ₂₄ —0.1- μ fd. 400-volt tubular	C ₃₅ —0.1- μ fd. 400-volt tubular	R ₅ —50,000 ohms, 1/2 watt
C ₁₃ —0.05- μ fd. 400-volt tubular	C ₂₅ —0.1- μ fd. 400-volt tubular	C ₃₆ —80-225- μ fd. mica trimmer	R ₆ —2000 ohms, 1/2 watt
C ₁₄ —0.00005- μ fd. mica	C ₂₆ —10- μ fd. 25-volt electrolytic	C ₃₇ , C ₃₈ —0.1 μ fd. 400-volt tubular	R ₇ , R ₈ —100,000 ohms, 1/2 watt
C ₁₅ —0.0001- μ fd. mica	C ₂₇ , C ₂₈ —0.1- μ fd. 400-volt tubular		

removed from the shield can and the leads from the original tickler winding disconnected from the terminals on the mounting strip. Next, 20 turns of small silk or cotton-covered wire should be wound around the dowel coil mount as close to the bottom of the original winding as possible. If this coil is wound in the same direction as the grid winding the proper method of connection will be as indicated on the diagram. The direction of the grid winding may be observed by noting the direction in which the grid lead enters the insulating compound.

After these changes have been made the trimmer condenser C₃₆ should be mounted

inside the shield can with its adjusting screw protruding through a hole in the top, and the grid leak and condenser assembly, R₁₈, C₁₇, mounted within the shield. It is a rather tight squeeze to get all of these components within the shield but it is quite necessary that they be placed there as any harmonics from this oscillator section reaching the r.f. section of the receiver might cause unwanted "phantom" carriers to appear. With the parts located as described, however, there is no trouble of this type. Shielded grid and cathode leads must be run from the coil terminals to the 6SA7 socket.

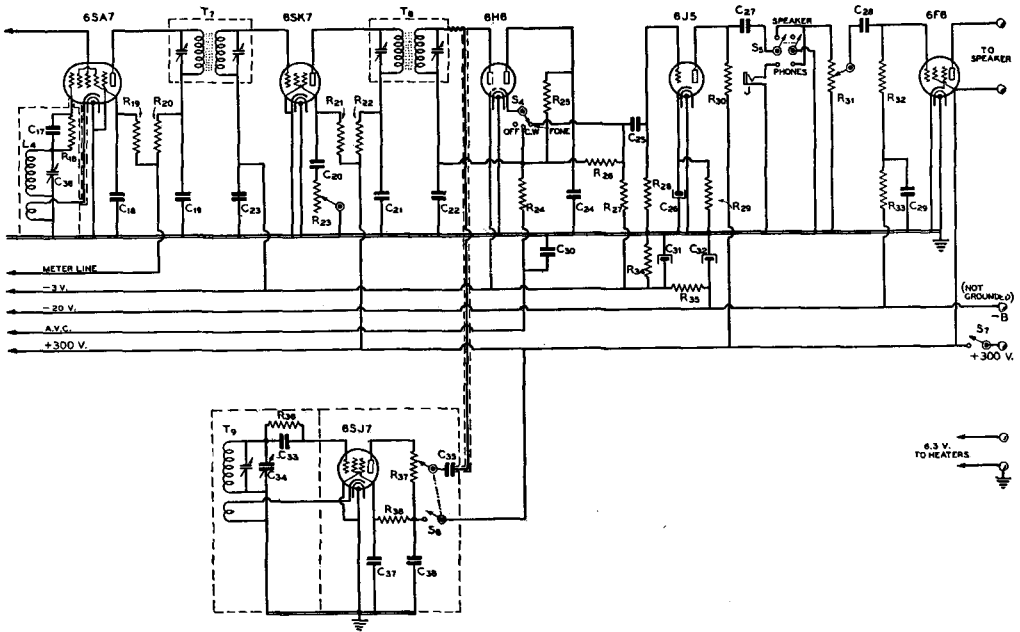

- R₉—2000 ohms, 1/2 watt
- R₁₀—100,000 ohms, 1/2 watt
- R₁₃, R₁₅—5000-ohm wire-wound potentiometer
- R₁₅—100,000 ohms, 1/2 watt
- R₁₄—2000 ohms, 10 watts
- R₁₅—1000-ohm wire-wound potentiometer
- R₁₀—2000 ohms, 1/2 watt
- R₁₇—40,000 ohms, 2 watts
- R₁₈, R₁₀—50,000 ohms, 1/2 watt
- R₂₀—2000 ohms, 1/2 watt
- R₂₁—100,000 ohms, 1/2 watt
- R₂₂—2000 ohms, 1/2 watt

- R₂₃—5000-ohm carbon potentiometer
- R₂₄—250,000 ohms, 1/2 watt
- R₂₅—1 megohm, 1/2 watt
- R₂₆—250,000 ohms, 1/2 watt
- R₂₇, R₂₈—1 megohm, 1/2 watt
- R₂₉—2500 ohms, 1/2 watt
- R₃₀—100,000 ohms, 1/2 watt
- R₃₁—500,000-ohm potentiometer
- R₃₂—250,000 ohms, 1/2 watt
- R₃₃—50,000 ohms, 1/2 watt
- R₃₄—15 ohms, 10 watts

- R₃₅—150 ohms, 10 watts
- R₃₆—100,000 ohms, 1/2 watt
- R₃₇—10,000-ohm potentiometer
- R₃₈—250,000 ohms, 1/2 watt
- T₁—1500-kc. input i.f. transformer
- T₂, T₃, T₄—1500-kc. interstage i.f. transformer
- T₅, T₆—Negative-mutual coupling coils (see text)
- T₇—175-kc. input i.f. transformer
- T₈—175-kc. diode output i.f. transformer
- T₉—175-kc. b.f.o. transformer

- L₁, L₂, etc.—See coil table
- L₄—B.c. band 465-kc. oscillator coil (see text)
- S₁—Three-section 3-pole, 3-position isolantite selector switch
- S₂, S₃—Single-pole double-throw switch (on gain control)
- S₄—Single-pole three-position noise limiter switch
- S₅—D.p.d.t. switch
- S₆—S.p.s.t. switch (on injection control, R₃₇)
- S₇—S.p.s.t. switch
- L_{1A}, C_{1A}, L_{2A}, C_{2A}, etc.—See coil table

175-Kc. Channel. The 175-k.c. i.f. channel is conventional except for the method of obtaining regeneration for single-signal reception of c.w. signals. The regeneration control, R₂₃, is placed between the ground side of the 6SK7 screen by-pass and ground. In some cases it may be necessary to place an additional capacity between the grid and plate of this stage to permit full regeneration to be obtained. The additional capacity can well consist of a short length of push-back wire connected to the grid terminal on the socket and run over near the plate terminal.

A 6H6 is used as the detector-noise limiter. One of the diodes serves as a diode detector

and a.v.c. rectifier, while the other diode performs the function of noise limiting. A three-position switch in the noise diode cathode allows either off, phone, or c.w. settings. Returning the cathode of the detector-a.v.c. diode to the -3 volt line insures a minimum 3-volt bias at all times on the stages operating from the a.v.c. line. The audio system following the detector is entirely conventional and needs no detailed comment.

Mechanical Layout

Looking at the receiver from the front, the components above the chassis are as follows: Along the right edge, from front

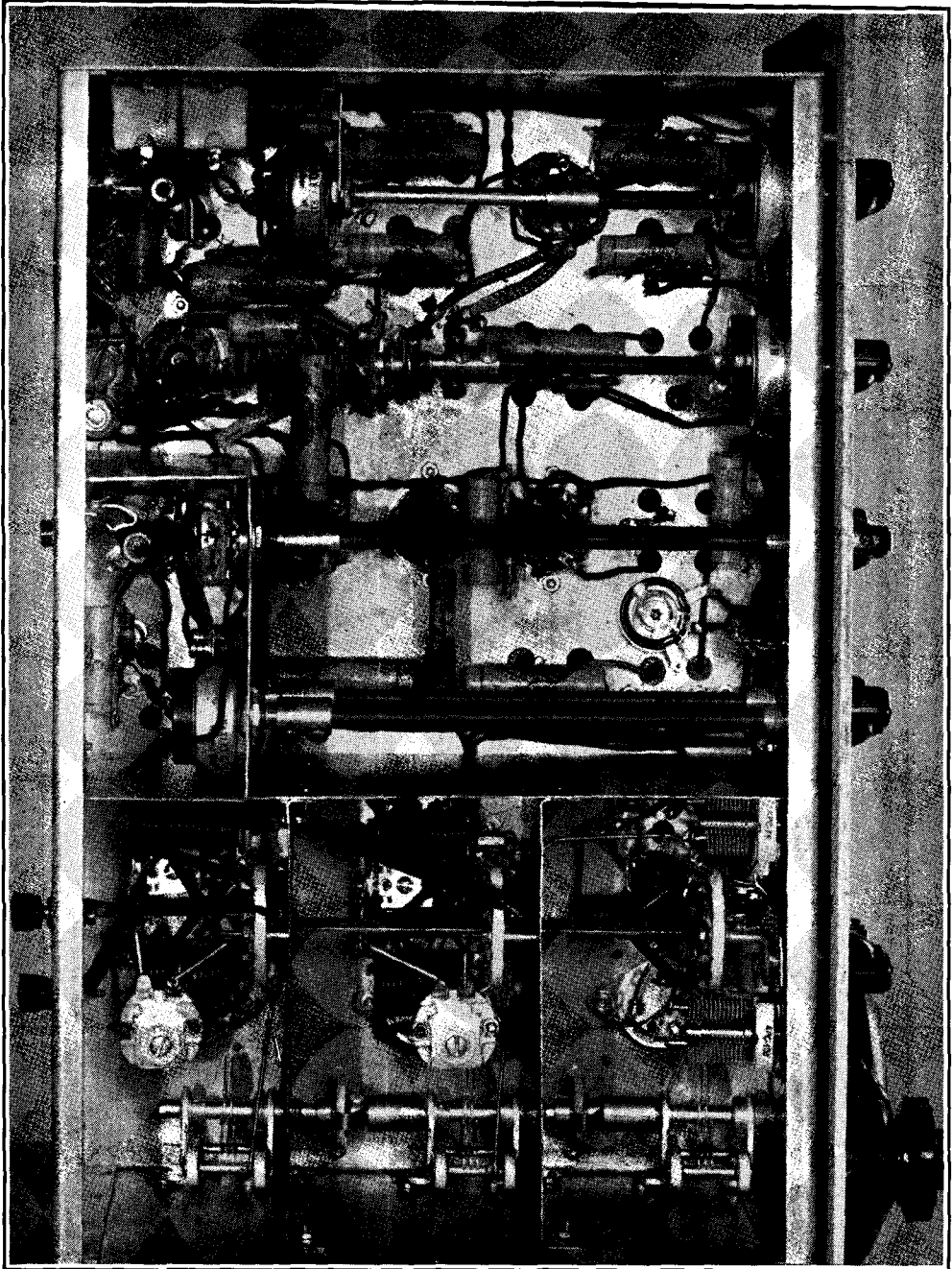

Figure 15.

UNDERNEATH THE CHASSIS OF THE ADVANCED SUPERHETERODYNE.

Note the "air-wound" 10- and 20-meter coils in the r.f., mixer and oscillator stages. The shield partition at the rear center of the chassis mounts the b.f.o. and audio controls.

to back, are the r.f., mixer, and oscillator stages. The 1500-k.c. i.f. channel progresses along the front of the chassis toward the left edge, where the 1500-k.c. to 175-k.c. mixer stage is located, with the 175-k.c. stage directly behind it along the left edge of the chassis. The audio section and the beat oscillator and voltage regulator are located in the rear-center portion of the chassis. The actual arrangement of the audio section is of little importance as long as the various controls associated with these circuits are reasonably close to the tubes with which they operate.

Underneath the chassis every effort should be made to keep all the grid and plate leads as short and direct as possible. This is particularly important in a receiver such as this, where single-ended tubes are used throughout. Large holes should not be cut under the i.f. transformers; small holes just large enough to allow the passage of the leads should be used.

The Bandswitch. The bandswitch is made up from parts supplied by the manufacturer in kit form. The first switch section, which includes the index assembly, is mounted directly on the front drop of the chassis. The two rear sections are supported from the two interstage shield partitions. In assembling the front end, the oscillator should be wired and tested first, and then the oscillator-mixer partition added. Next, the mixer should be wired and

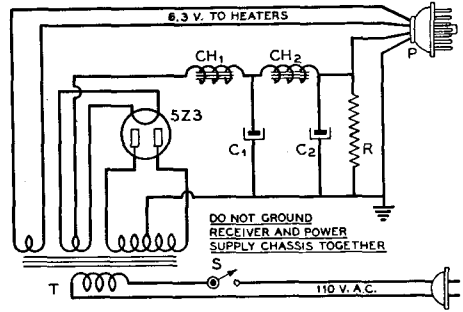

Figure 16.
POWER SUPPLY FOR RECEIVER OF FIGURE 14.

- T—750 v., c.t., 150 ma.;
- 5 v., 3 a.; 6.3 v., 5 a. electrolytic
- CH₁, CH₂—30 hy., 100 R—50,000 ohms, 20 watts
- S₁—S.p.s.t. switch

tested and the remaining shield partition installed, the assembly progressing from front to rear until this whole section of the receiver is completed. It is necessary to drill a hole in the rear drop of the chassis to allow the flat shaft for revolving the switch sections to be installed. This hole can well be used to mount the antenna binding post.

The chassis measures 6x10x15 inches, and the panel 11x18 inches.

Alignment. After all wiring has been completed and checked, the i.f. channels

	R.F.			DET.			OSC.		CATHODE TAP	
	ANTENNA	GRID	B. S. TAP	PLATE	GRID	B. S. TAP	GRID	B. S. TAP		
80	5 t. close wound	29½ t. spaced to 1½". Padder 25-100 mica	to grid end	10 t. close wound	29½ t. spaced to 1½". Padder 25-100 mica	to grid end	20½ t. spaced to 1½". Padder 100 air	16 t.	3 t.	all no. 22 d.c.c. all wound on 1½" forms
40	5 t. no. 22 d.c.c. close wound	17½ t. no. 18 enam. spaced to 1½". Padder 25-100 mica	8 t.	10 t. no. 22 d.c.c. close wound	17½ t. no. 18 enam. spaced to 1½". Padder 25-100 mica	8 t.	13½ t. no. 18 enam. spaced to 1½". Padder 100 air	7 t.	2 t.	all no. 22 d.c.c. all wound on 1½" forms
20	6 t. no. 20 hookup wire inside grid coil at ground end	13 t. no. 16 enam. ¾" dia. spaced to 1½". Padder 25-100 mica	5½ t.	6 t. no. 20 hookup wire inside grid coil at ground end	13 t. no. 16 enam. ¾" dia. spaced to 1½". Padder 25-100 mica	5½ t.	13½ t. no. 16 enam. ¾" dia. spaced to 1½". Padder 100 air	6 t.	2½ t.	
10	5 t. no. 20 hookup wire inside grid coil at ground end	13 t. no. 16 enam. ½" dia. spaced to 1½". Padder 3-30 mica	5 t.	5 t. no. 20 hookup wire inside grid coil at ground end	13 t. no. 16 enam. ½" dia. spaced to 1½". Padder 3-30 mica	5 t.	6 t. no. 16 enam. ½" dia. spaced to ¾". Padder 75 air	4 t.	1½ t.	

All taps refer to number of turns up from ground end of coil. Note that grid coil is same for both r. f. and detector on all bands. 80 and 40 m. coils are plug in.

COIL TABLE FOR DELUXE RECEIVER

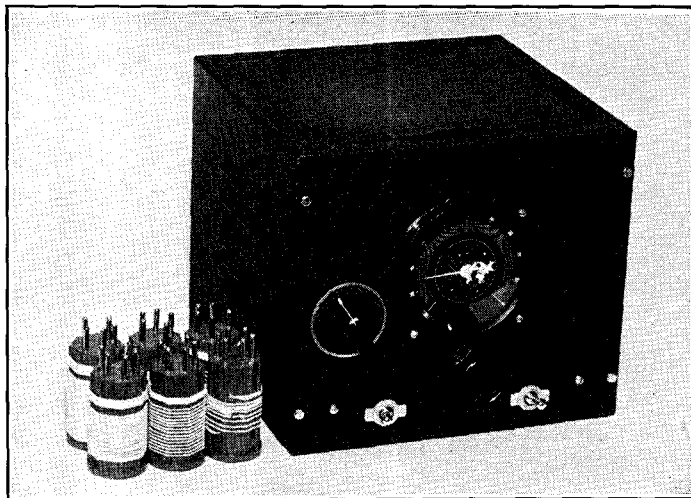

Figure 17.
FRONT VIEW OF THE CON-
VERTER INSTALLED IN ITS
METAL CABINET.

The coils for the 80-, 40- and 20-meter bands are shown to the left of the unit. The front panel controls are: oscillator bandset, bandspread, and detector tuning; the left-hand switch is for filament voltage and the one to the right controls the b.f.o.

should be aligned. A calibrated signal generator is almost a necessity during the alignment process. First the 175-kc. channel should be aligned. If the receiver has been wired correctly this should be quite easy, remembering that the regeneration control should be turned completely "off," that is, with the resistance all out of the circuit. When the 175-kc. stage has been aligned properly, the signal generator should be set at 1500 kc. and shifted to the grid of the second mixer. With the signal generator output connected into this circuit, adjust the 6SA7 oscillator-section trimmer (C_{36}) until the signal from the generator is heard at the output of the receiver. The second mixer is now converting from 1500 to 175 kc. and the 1500-k.c. channel may be aligned in the usual manner.

Power Supply. Two octal sockets are provided at the rear of the chassis for speaker and power supply connections. The additional contacts on these sockets may be used to bring leads for transmitter remote control and other remote switching circuits into the receiver. The power supply is strictly conventional; a diagram is shown in figure 16.

BATTERY OPERATION

When a.c. power is not available, the simple regenerative receiver described at the beginning of this chapter may be run economically entirely from batteries. If dry batteries are to be used for filament supply, it is recommended that a 6S7 be substituted for the 6J7 and that a 6L5-G be substituted

for the 6C5. These tubes are almost identical to the 6J7 and 6C5 except that they draw only half the heater current, and their slightly greater cost will be repaid many times if dry batteries are used to supply the heaters.

As high transconductance heater type tubes may be run satisfactorily at considerably reduced heater voltage if the tube is not drawing heavy plate current, only 4.5 volts are required for full performance. Three standard no. 6 dry cells in series will give over 150 hours life when the low drain tubes are used.

The more elaborate receivers in this chapter can be run from a storage battery and heavy duty B batteries, 0.15 amp. heater tubes being substituted to advantage when the tubes specified in the diagram have a low-drain counterpart. The audio output tube can be over biased to keep the plate current down to the lowest value that will still permit sufficient output without objectionable distortion. Generally speaking, receivers designed for 250 volt operation will work practically as well on four 45 volt B batteries.

Vibrator power supplies can be used for plate voltage, but as a general rule will require elaborate filtering to avoid "hash" in the receiver on the higher frequencies.

BATTERY CONVERTER

When a highly sensitive and selective receiver that can be run entirely from dry batteries is desired, the recommended course is to purchase (if not already owned) one

Figure 18.

UNDER-CHASSIS VIEW.

Note the strap which holds the filament battery in place, the miniature sockets for the miniature tubes, and the screwdriver-set neutralizing condenser between the detector coil socket and the oscillator-grid terminal on the mixer tube.

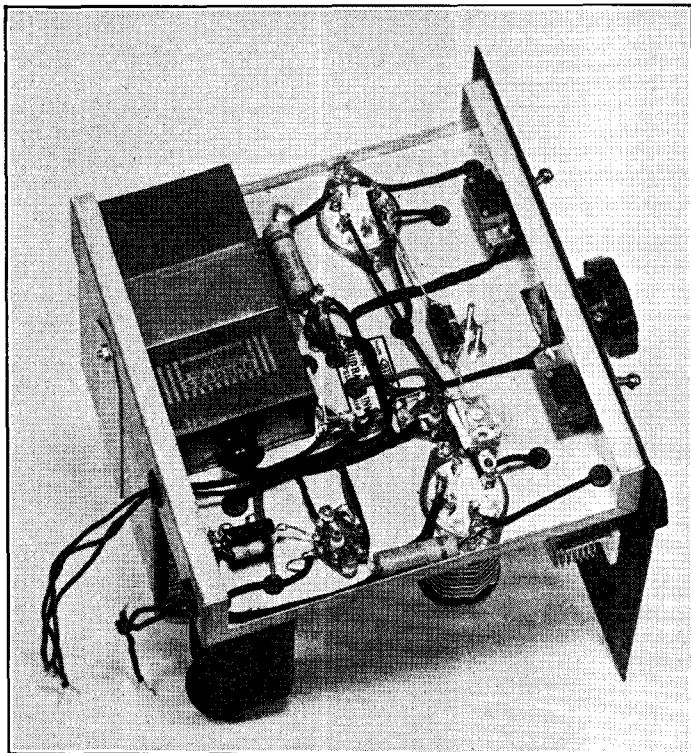

of the new portable, battery powered broadcast receivers and use it in conjunction with the following battery powered 10-80 meter converter. For home use, the converter can be used with any battery operated broadcast receiver having good sensitivity and selectivity.

The unit consists of a 1R5 "button" type pentagrid converter and a 1T4 beat frequency oscillator of the same miniature type. Use of these tubes permits efficient operation at only 45 volts plate supply.

For phone work, only the 1R5 is used, and the 1T4 filament is switched off to conserve the filament power. No coupling other than stray circuit capacity is used to couple the b.f.o., the amount of coupling present being just about right for giving a good beat on loud signals without masking weak signals.

Mechanical Construction. The complete converter is built into a small 8" by 8" by 7" cabinet of standard manufacture. The chassis is also a standard unit and is designed to be used with this particular cabinet.

Three controls and the two filament switches are mounted upon the front panel. The left control is the knob on the handset

control which consists of a 100- μ fd. variable connected across the h.f.o. coil. The center condenser is a 35- μ fd. midget and is controlled by an inexpensive 3-inch "airplane" dial. The right-hand control is the detector tuning condenser and consists of a 50- μ fd. midget connected directly across the grid coil.

A glance at the under-chassis and the top-chassis view will show that each battery is mounted by means of a piece of metal strap about 1 $\frac{1}{4}$ inches wide. The filament battery is of a convenient size to fit snugly below the chassis, and the plate 45-volt B battery, when turned on its side, is just about the same height as the i.f. and b.f.o. transformers.

Aside from this there are few points concerning the construction of the unit that will not be immediately apparent from the photographs. However, one thing that should be mentioned is that care must be taken in inserting the miniature tubes into their sockets for the first time. The element-connection prongs for the tubes are merely extended pieces of molybdenum wire which are sealed into the glass base of the tube. If too much strain or tension is placed upon these wires

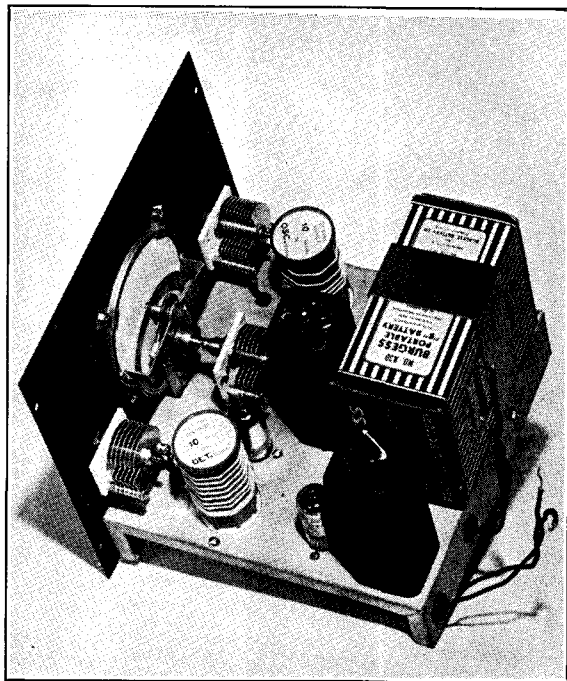

Figure 19.

**TOP VIEW OF THE CHASSIS
REMOVED FROM THE CABINET.**

The miniature mixer tube can be seen between the detector coil and the bandspread condenser, and the b.f.o. tube is placed just in front of the b.f.o. coil. The five leads coming out of the rear of the chassis are soldered to a terminal strip on the rear of the box which houses the unit.

there is a possibility that the glass envelope or the glass base of the tube may be fractured.

The plate of the 1R5 mixer feeds into a 1600-kc. double-tuned i.f. transformer which has been revamped to give low-impedance output in addition to the output voltage from the other high-impedance winding on the transformer. The low-

impedance winding consists simply of about 10 turns wound on the end of the dowel just below the winding which feeds the plate of the 1R5. One side of both the low-impedance winding and the high-impedance winding is grounded.

Normally the low-impedance winding will be used to couple the converter to the receiver, the two wires from the 10 turn winding simply being connected to the antenna and ground posts on the receiver. If the receiver happens to be of the small portable type having a loop antenna and no provision for connecting an external antenna, the grid clip should be removed from the first tube in the receiver and a wire run from the grid of the tube to the no. 2 output terminal of the converter. This lead should be kept as short as possible. A wire also should be run from the ground terminal of the converter to the chassis of the receiver, so that there will be a bias return for the first tube in the receiver.

An alternative method that can be used when the receiver has no provision for an external antenna is to wind 2 or three turns of wire into approximately the same shape as the loop antenna and fasten these turns to the cabinet so as to be in close inductive relation to the loop. These turns are then

Coil Table

All coils are wound on 1¼-inch diameter forms with no. 22 d.c.c. wire.

80-Meter Oscillator—22 turns 1¼ inches long, tap 15 t. from ground, tickler 6 turns.

80-Meter Detector—45 turns closewound, antenna coil 7 turns closewound.

40-Meter Oscillator—15 turns 1¼ inches long, tap 7 t. from ground, tickler 4 turns.

40-Meter Detector—30 turns closewound, antenna coil 6 turns closewound.

20-Meter Oscillator—7 turns 1 inch long, tap 3 turns from ground, tickler 3 turns interwound.

20-Meter Detector—14 turns 1½ inches long, antenna coil 5 turns closewound.

10-Meter Oscillator—3 turns 1¼ inches long, tap 1 turn from ground, tickler 2 turns interwound.

10-Meter Detector—7 turns 1¼ inches long, antenna coil 4 turns.

- C₁—50- μ fd. midget variable
 C₂—35- μ fd. bandsread variable
 C₃—100- μ fd. bandset variable
 C₄—0.0001- μ fd. midget mica
 C₅—0.1- μ fd. 600-volt tubular
 C₆—0.0001- μ fd. midget mica
 C₇—0.1- μ fd. 600-volt tubular
 C₈—330 μ fd. isolantite trimmer
 R₁—100,000 ohms, 1/2 watt
 R₂—100,000 ohms, 1/2 watt
 R₃—75,000 ohms, 1/2 watt
 L₁, L₂—See coil table
 IFT—1500 kc. i.f. trans. with 10 coupling turns added
 BFT—1500 kc. beat osc. trans.
 S₁—On-off switch
 S₂—B.f.o. on-off switch

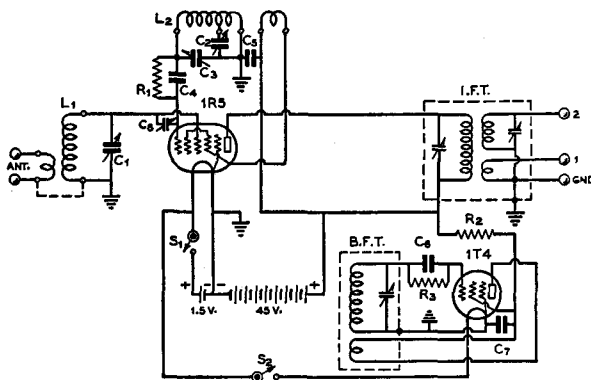

Figure 20.
WIRING DIAGRAM OF THE BATTERY POWERED CONVERTER.

connected to terminals 1 and gnd. the same as for a regular antenna coil.

Tuning Up. Tuning up the converter is a comparatively simple process provided the coil table has been followed exactly and provided a high-gain broadcast receiver is available for the first test. The b.e.l. set is first tuned to 1600 kc. (or a point close to that frequency where no b.e. or police stations are audible) and the gain turned up until background noise can be heard. The 40-meter coils are plugged into the set and the filament switch turned on.

With the bandset condenser on the oscillator at about half scale, tune the primary on the 1600-ke. output i.f. transformer in the converter at the same time that the detector tuning condenser is being rotated back and forth. A point will be found where the hiss (or perhaps a signal) comes in loudest. A retrimming of the i.f. transformer and of the detector tuning will then complete the tuning.

Note that 6-prong forms have been used for the oscillator coils and 5-prong ones for the detector. This has been done simply to insure that the proper coils will be inserted into the proper places.

It will be found best to have the ten-meter coils in the converter when the neutralizing condenser C₈ is being adjusted. Set the bandset condenser to about 60, tune in a signal on the bandsread dial, and peak it up on the detector condenser. Then adjust C₈ back and forth until rotating the detector condenser back and forth gives the least "pulling" of the oscillator. The best setting will be found with the open edges of the neutralizing condenser separated about one-eighth inch. At the proper setting there will

be only a very small amount of pulling on the ten-meter coils and a negligible amount on the lower frequency bands.

HIGH GAIN 5-BAND PRESELECTOR

If a superheterodyne has less than two stages of preselection, its performance can be greatly improved by the addition of this high gain preselector. The improvement in image ratio and signal-to-noise ratio will be most noticeable on the higher frequency

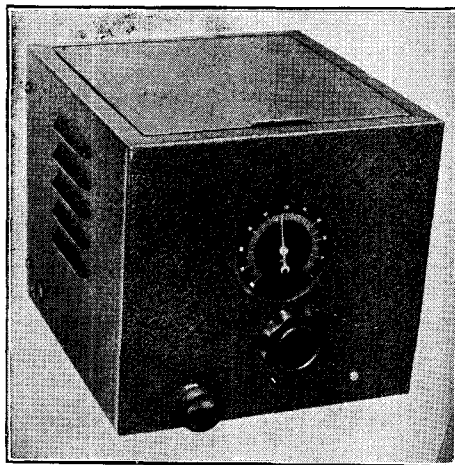

Figure 21.
5-BAND HIGH GAIN PRESELECTOR.
This high gain preselector uses an 1851 tube, tuned output circuit and moderate regeneration. It makes a worthwhile addition to any receiver having less than two r.f. stages.

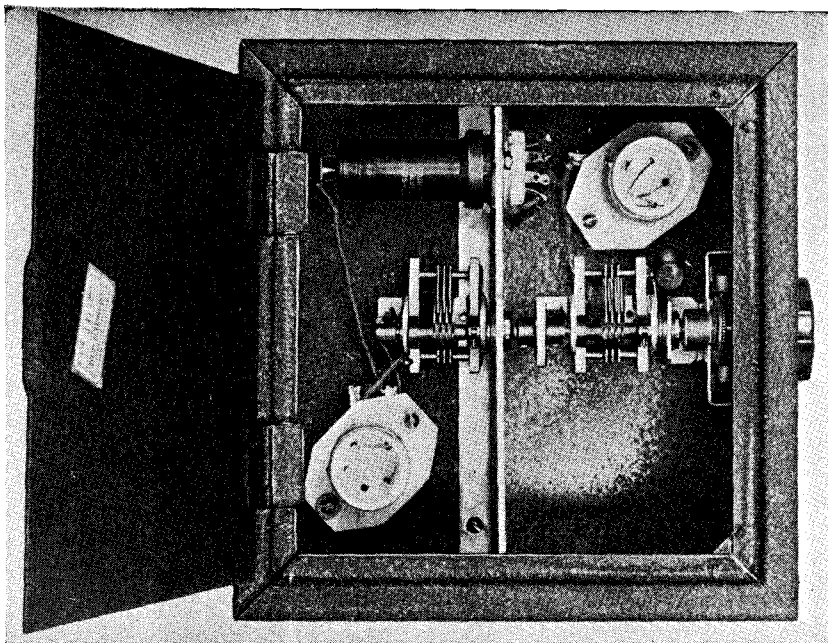

Figure 22.
LOOKING DOWN INTO THE 1851 HIGH GAIN PRESELECTOR.
 An aluminum partition shields the input from the output circuit, and serves as a support for the tube and rear tuning condenser.

bands and will be especially noticeable if the receiver itself has no r.f. stage at all.

The preselector uses a type 1851 pentode. This tube has a low noise level and extremely high transconductance. In fact, it is necessary to tap the plate of the tube down from the "hot" end of the tuned plate coil in order to avoid oscillation.

The tuned plate circuit is link-coupled to the input terminals of the receiver to which the preselector is to be attached. The coupling link is of the coaxial type, made of flexible shielded conductor. The use of a

tuned output circuit and an efficient coupling system makes this preselector greatly superior in performance to the simpler, more common type of one-stage preselector in which the plate of the preselector tube is capacitively coupled to the antenna post of the receiver.

The preselector is moderately regenerative; in fact, it will tend to oscillate unless the input circuit is rather heavily coupled to an antenna.

The 1851 has a very low input resistance, especially on 10 meters. For this reason the

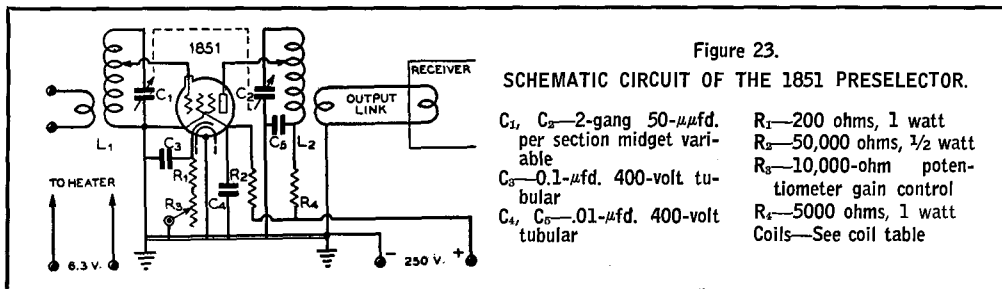

1851 PRESELECTOR COIL DATA

COIL BAND	GRID COIL	PLATE COIL
10	8 turns #20 d.c.c. 1 1/8" diam. 1" long center tapped Primary— 2 turns	Same as grid coil Secondary— 2 turns
20	15 turns #20 d.c.c. 1 1/8" diam. 1" long center tapped Primary— 3 turns	Same as grid coil Secondary— 2 turns
40	24 turns #22 d.c.c. 1 1/2" diam. 1 1/2" long tap at 10 turns Primary— 5 turns	Same as grid coil tap at 12 turns Secondary— 3 turns
80	44 turns #24 d.c.c. 1 1/2" diam. 1 1/2" long tap at 15 turns Primary— 8 turns	Same as grid coil tap at 15 turns Secondary— 3 turns
160	80 turns #26 enam. 1 1/2" diam. closewound tap at approx. 20 turns Primary— 12 turns	Same as grid coil Secondary— 3 turns

grid is tapped down on the input coil, being connected approximately to the center of the coil. This reduces the grid loading to one-quarter without reducing the input voltage, due to the higher Q obtained with the tapped arrangement. Not only are selectivity and image rejection greatly improved, but tracking is greatly simplified by tapping down on the grid coil.

Tapping the grid and plate leads down on their respective coils effectively reduces the minimum shunt capacities, thus allowing a greater tuning range with a given tuning condenser. With the 50- $\mu\mu\text{fd}$. tuning condensers illustrated, approximately a 2-1 range in frequency is possible with each set of coils. This gives practically continuous coverage of the short-wave spectrum with the coils listed in the coil table. The coils cover

the following ranges: 1.7 to 3.5 Mc., 3 to 6 Mc., 6.5 to 11 Mc., 10 to 19 Mc. and 18 to 33 Mc. Thus, the preselector can be used effectively with communication receivers of the continuous coverage all-wave type.

If oscillation is troublesome even when tight antenna coupling is used, the plate coil can be tapped a little farther down towards the ground (B plus) end.

If desired, a 6J7 or 6K7 can be used in place of the 1851. If one of these tubes is used, both grid and plate should be connected directly to the "hot" ends of their respective coils, instead of to the center. The gain will not be quite as high as with an 1851 and the tuning range will be reduced slightly. The latter can be offset by using 75- $\mu\mu\text{fd}$. tuning condensers instead of 50- $\mu\mu\text{fd}$. condensers.

Tracking can be checked by rotating the rear tuning condenser separately while listening to a station and watching the R meter.

Construction. The unit is built in a 7"x-7"x7" cabinet and chassis. A 6 1/4"x5 1/4" aluminum partition with a 1/2-in. lip to permit fastening to the chassis as illustrated in figure 36 shields the input from the output circuits. The rear tuning condenser is mounted on this partition and driven from the front condenser by means of an insulated coupling. While the tube is shown mounted horizontally, it could be just as well mounted vertically; the leads would be just about as short.

For maximum gain on the higher frequency range, tuning condensers, sockets and coil forms should have ceramic insulation.

Most receivers will stand a slight additional drain on the plate and filament supplies without overheating. For this reason, the preselector voltages may be robbed from the receiver with which it is to be used. If the receiver power supply already runs quite hot, indicating that it is being overloaded, a separate power supply is advisable for the preselector.

A 6K7 may be substituted for the 1851 with a slight loss in gain. If a 6K7 is used, R₂ should be increased to 100,000 ohms and both grid and plate should connect directly to the tuning condensers rather than to a center tap on the coil.

CHAPTER SEVEN

Transmitter Theory

The general function of a transmitter is to generate a signal of a desired frequency and to modulate this signal in accordance with the intelligence to be transmitted. The radio frequency energy from the transmitter is most commonly carried by a *transmission line* to a radiating system or *antenna* from whence the intelligence-carrying energy is radiated into space. Transmission lines and antennas will be treated in the chapter devoted to *Antennas*; the theory of operation of the various divisions of the transmitter proper will be discussed in the following pages.

The usual transmitter will contain the following general divisions: an oscillator, either crystal or self-controlled; one or more frequency multiplying stages; one or more radio-frequency amplifying stages and a system for either keying or modulating by voice the output of the final amplifier stage. However, a transmitter need not necessarily have all the stages mentioned above, and, in fact, may be merely an oscillator whose output is controlled by a telegraph key.

Oscillators

As was mentioned earlier, in the chapter devoted to the theory of vacuum tubes, the amplifying properties of a tube having three or more elements give it the ability to generate an alternating current of a frequency determined by the components associated with it. A vacuum tube operated in such a circuit is called an oscillator, and its function is essentially to convert a source of direct current into radio frequency alternating current of a predetermined frequency. Oscillators for controlling the frequency of conventional radio transmitters can be divided into two general classifications: self-controlled and crystal-controlled.

There are a great many types of self-controlled oscillators, each of which is best suited to a particular application. They again can further be subdivided into the classifica-

tions of: negative-grid oscillators, electron-orbit oscillators, and negative-resistance oscillators.

Negative-Grid Oscillators. A negative-grid oscillator is essentially a vacuum-tube amplifier with a sufficient portion of the output energy coupled back into the input circuit to sustain oscillation. They are called negative-grid oscillators because, in contrast to certain other oscillator circuits, the grid is biased a considerable amount negative with respect to the cathode. It is this classification of oscillator which finds most common application in low- and medium-frequency transmitter control circuits. The various common types of negative-grid oscillators are diagrammed in figure 1.

The Hartley. Figure 1 (A) illustrates the oscillator circuit which finds the most general application at the present time; this circuit is commonly called the Hartley. The operation of this oscillator will be described as an index to the operation of all negative-grid oscillators; the only real difference between the various circuits is the manner in which energy for excitation is coupled from the plate to the grid circuit.

Operation of the Hartley Oscillator. When the plate voltage is applied to the plus and minus terminals of the Hartley oscillator shown at (A), the sudden flow of plate current accompanying the application of plate voltage will cause an electro-magnetic field to be set up in the vicinity of the coil. The building-up of this field will cause an instantaneous potential drop to appear from turn-to-turn along the coil. Due to the inductive coupling between the portion of the coil in which the plate current is flowing and the grid portion, a potential will be induced in the grid portion. Since the cathode tap is between the grid and plate ends of the coil, the induced grid voltage acts in such a manner as to increase further the plate current to the tube. This action will continue for a small period of time determined by the inductance

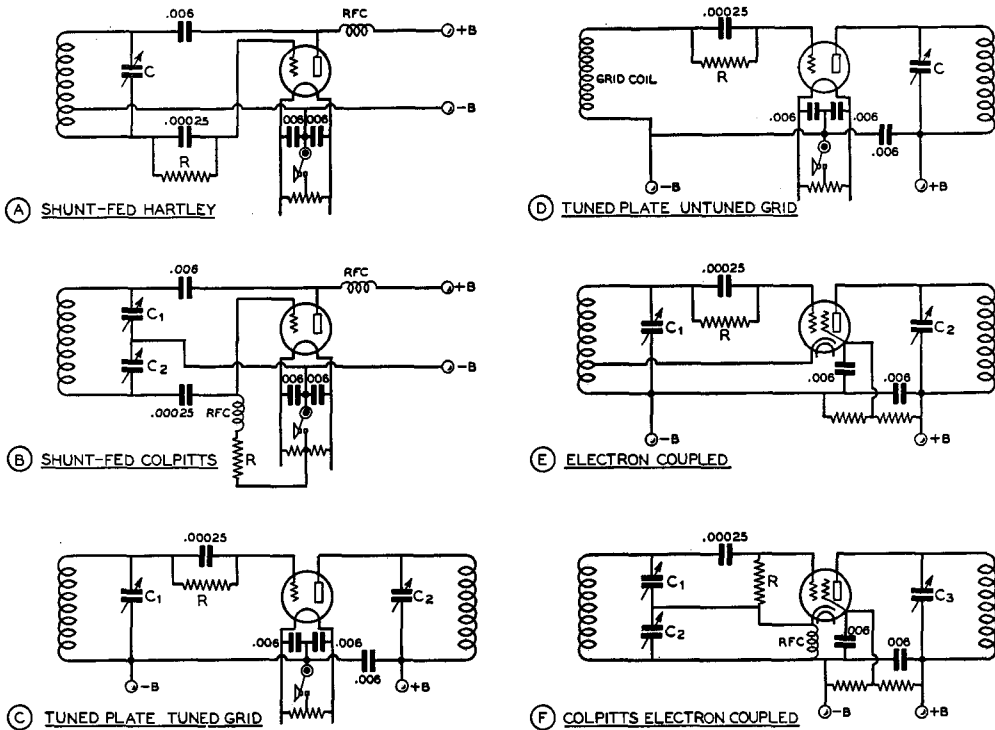

Figure 1.
COMMON TYPES OF SELF-EXCITED OSCILLATORS.

and capacity of the tuned circuit, until the "flywheel" effect of the tuned circuit causes this action to come to a maximum and then to reverse itself. The plate current then decreases, the magnetic field around the coil also decreasing, until a minimum is reached when the action starts again in the original direction and at a greater amplitude than before. The amplitude of these oscillations, the frequency of which is determined by the coil-condenser circuit, will increase in a very small period of time to a limit determined by the plate voltage or the cathode emission of the oscillator tube.

The Colpitts. Figure 1 (B) shows a version of the colpitts oscillator. It can be seen that this is essentially the same circuit as the Hartley except that a pair of capacitances in series are employed to determine the cathode tap, instead of actually using a tap on the tank coil. Also, the net capacity of these two condensers comprises the tank capacity of the tuned circuit.

The T.P.T.G. The tuned-plate tuned-grid or t.p.t.g. oscillator illustrated at (C) has a

tank circuit in both the plate and grid circuits. The feedback of energy from the plate to the grid circuits is accomplished by the plate-to-grid interelectrode capacity within the tube.

For best operation of the Hartley and Colpitts oscillators the voltage from grid to cathode, determined by the tap on the coil or the setting of the two condensers, should be from one-third to one-fifth that appearing between plate and cathode. In the t.p.t.g. oscillator the grid circuit should be tuned to a frequency slightly lower than that of the plate circuit for best operation. The frequency of oscillation is determined primarily by the constants of the plate circuit, and therefore a broadly resonant or aperiodic coil may be substituted for the grid tank to form the T.N.T. oscillator shown at (D).

Electron-Coupled Oscillators. In any of the three oscillator circuits just described it is possible to take energy from the oscillator circuit by coupling an external load to the tank circuit. Since the tank circuit determines the frequency of oscillation of the tube, any variations in the conditions of the external

circuit will be coupled back into the frequency determining portion of the oscillator. These variations will result in frequency instability.

Two oscillators in which the frequency determining portion of the oscillator is coupled to the load circuit only by an electron stream are illustrated in (E) and (F) of figure 1. When it is considered that the screen of the tube acts as the plate to the oscillator circuit, the plate acting as a coupler to the load, then the similarity between the cathode-grid-screen circuit of these oscillators and the cathode-grid-plate circuits of the corresponding prototype.

The advantage of the electron-coupled oscillator over conventional types is in the greater stability with respect to load and voltage variations that can be obtained. Load variations have very little effect on the frequency of operation of the e.a.o., since the only coupling between the oscillating circuit and the load is through the electron stream flowing through the other elements to the plate. The plate is electrostatically shielded from the oscillating portion by the screen, which is at ground potential with respect to r.f.

The stability of the electron-coupled type of oscillator with respect to variations in supply voltages comes from an entirely different source. It is a peculiarity of such an oscillator that the frequency will shift in one direction with an increase in screen voltage while an increase in plate voltage will cause it to shift in the other direction. By a proper proportioning of the resistors that comprise the voltage divider supplying screen voltage, it is possible to make the frequency of the oscillator substantially independent of supply voltage variations; the tendency of an increase in screen voltage to make the frequency shift in one direction is counterbalanced by the effect of the increase in plate voltage to make the frequency shift in the other direction.

V. F. O. Transmitter Controls. During the last year or two there has been an increasing tendency to break away from the standard crystal oscillator as the only means of controlling the frequency of a transmitter because of the necessarily limited flexibility of such an oscillator. The new tendency has been toward the use of highly stabilized *variable-frequency oscillators* as transmitter controls in amateur equipment. These oscillators are nothing more than certain types of self-excited oscillators in which adequate precautions have been taken to insure that they shall be as stable as possible with respect to load and supply voltage variations.

Due to the better inherent stability of the electron-coupled type of oscillator, a number of the recent designs for *v.f.o.'s* (as the variable-frequency oscillators for transmitter frequency control are called) have used this type of oscillator. However, one disadvantage of the electron-coupled oscillator is that the cathode and heater are not at the same r.f. potential. This gives rise to difficulties due to heater-cathode leakage, heater-cathode capacity variation with changes in temperature, and coupling of stray r.f. energy from the heater into the cathode circuit.

As a consequence of this disadvantage of the electron-coupled oscillator, another group of the recent designs for *v.f.o.'s* (variable-frequency oscillators) have used grounded-cathode oscillator circuits of the modified Hartley type. A *v.f.o.* of this design is shown in the chapter *Exciters and Low-Powered Transmitters*. Since the cathode of an oscillator of this type is at ground potential, it is impossible for r.f. energy from an external source to be coupled into the oscillating circuit from the heater circuit. However, the use of any type of oscillator as a transmitter control means that it must be carefully constructed, both from the electrical and from the mechanical standpoint.

Other Oscillator Circuits

Electron-Orbit Oscillators. Of the other oscillator circuits the negative-resistance and electron-orbit types are the most common of the self-excited class. Electron-orbit oscillators are used only for extremely high-frequency work (above 300 Mc.) and depend for their operation upon the fact that an electron takes a finite time to pass from one element to another inside a vacuum tube. The Gill-Morrell, Barkhausen-Kurtz, and Kozanowski oscillators are examples of this type and are described in the *Ultra-High Frequency Transmitters* chapter. Another special type of u.h.f. oscillator is the *magnetron*, which is also described in the u.h.f. chapter. This type employs a filament surrounded by a split plate to which are connected rods comprising a linear tank circuit. The tube is operated in a strong magnetic field; hence the name, magnetron.

Negative Resistance Oscillators. The other common type is the negative-resistance oscillator, which is used when unusually high frequency stability is desired, as in a frequency meter. The dynatron of a few years ago and the transitron of more recent fame are examples of oscillator circuits which make use of the negative resistance characteristic

between different elements in a multi-grid tube. In the dynatron the negative resistance is a consequence of secondary emission of electrons from the plate of the tube. By a proper proportioning of the electrode voltages an increase of screen voltage will cause a decrease in screen current; from this comes the term, *negative resistance*. A similar effect in the *transitron* is produced by coupling the screen to the suppressor; the negative resistance in this case is due to interelectrode coupling rather than to secondary emission.

The Franklin Oscillator. Another circuit which makes use of two cascaded tubes to obtain the negative-resistance effect is the Franklin oscillator illustrated in figure 2. The tubes may be either a pair of triodes, tetrodes, or pentodes, a dual triode, or a combination of a triode and a multi-grid tube. The chief advantages of this oscillator circuit are that only very loose coupling between the two tubes and the tank circuit, LC, is required, and that the frequency determining tank only has two terminals and one side of the circuit is grounded. Condensers C_1 and C_2 need be only one or two $\mu\text{fd.}$ for satisfactory operation of the oscillator; this means that tube capacity and input resistance variations will have only an extremely small effect on the frequency of oscillation.

Crystal Controlled Oscillators

When it is desired to hold the frequency of a transmitter very closely to a certain definite value or to keep it within an assigned frequency tolerance, reliance is very commonly placed upon the *piezo-electric* properties of a plate cut from a natural crystal of quartz. Quartz crystals are very widely employed by amateurs and commercial services as frequency controls; hence some of the important characteristics of piezo-electric minerals will be mentioned before entering into a discussion of the oscillators that make use of these characteristics for frequency control.

Quartz Crystals. Quartz and tourmaline are naturally occurring crystals having a structure such that when plates are cut in certain definite relationships to the crystallographic axes, these plates will show the piezo-electric effect—the plates will be deformed in the influence of an electric field, and, conversely, when such a plate is compressed or deformed in any way a potential difference will appear upon its opposite sides.

When such a quartz plate is placed in a circuit with a vacuum-tube amplifier having the output circuit coupled back into the input, and a tuned circuit in series with the

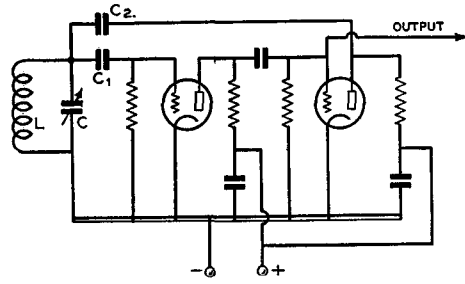

Figure 2.

THE FRANKLIN OSCILLATOR CIRCUIT.

In this oscillator a separate phase-inverter tube is used to feed a portion of the output back into the input circuit in the proper phase to sustain oscillation.

plate of the amplifier tube, the circuit will self-oscillate at a frequency primarily determined by the frequency of mechanical resonance of the quartz plate. The frequency of mechanical resonance or frequency of oscillation of a quartz plate is dependent upon its physical dimensions and upon a constant determined by the crystallographic (or optical) cut of the plate. The stability of the frequency of oscillation of a crystal controlled oscillator is dependent upon the Q of the quartz plate (determined by the optical cut, the accuracy of grinding, and the method of mounting) and upon the coefficient of temperature drift which is determined primarily by the optical cut of the plate.

Crystal Cuts. The face of an X cut or Y cut crystal is made parallel to the Z axis in figure 3. Special cut crystals, known as AT cut, V cut, LD2, HF2, etc., are cut with the face of the crystal at an angle with respect to the Z axis, rather than being parallel to it. The purpose of the special cuts is to increase the power handling ability of the plates in some cases, but especially to reduce their temperature coefficient. AT, V, B5 and LD2 cut crystals have temperature coefficients approaching zero, and they should be used in radio transmitters in which accurate frequency control is essential. These crystals eliminate the need of a crystal oven for amateur work. A constant operating temperature is still required for many commercial applications, but the oven temperature need not be kept within as close limits as for an X or Y cut plate.

Spurious Peaks. Crystals that oscillate at more than one frequency are commonly known as crystals with multiple peaks. The dual vibrational tendency is more pronounced with

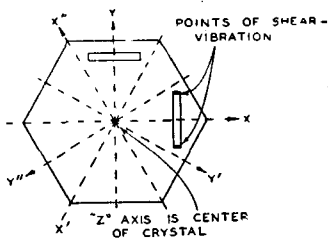

Figure 3.
SECTION THROUGH A QUARTZ CRYSTAL
SHOWING THE AXES OF THE RAW QUARTZ.

Y cuts, but to a certain degree is exhibited by many X cuts. The use of a well designed, space-wound, low C tank coil in an oscillator will tend to discourage the crystal from oscillating at two frequencies, and in addition will increase the output. Experiments have shown that the frequency stability is not improved by large tank capacities, which only tend to augment the double frequency phenomenon.

Twin frequencies appear in several ways: sometimes the crystal will have two frequencies several hundred cycles apart, and will oscillate on both frequencies at the same time to produce an acoustically audible beat note. Other crystals will suddenly jump frequency as the tank tuning condenser is varied past a certain setting. Operation with the tank condenser adjusted near the point where the frequency shifts is very unstable, the crystal sometimes going into oscillation on one frequency and sometimes on the other as the plate voltage is cut on and off. Still other crystals will jump frequency only when the temperature is varied over a certain range. And some plates will jump frequency with a change in either tank tuning or temperature.

Edge-of-Band Operation. When operating close to the edge of the band, it is advisable to make sure that the crystal will respond to but one frequency in the holder and oscillator in which it is functioning; any crystal with two peaks can jump frequency slightly without giving any indication of the change in the meter readings of the transmitter. If the transmitter frequency is such that operation takes place on the edge of the band at all times, under all conditions of room temperature, some form of temperature control will be required for the crystal unless it is of the zero drift type.

When working close to the edges of the 14 or 28 Mc. band, it is essential that the crystal temperature be kept at a fairly constant value; the frequency shift in kilocycles per degree increases in direct proportion to the

operating frequency, regardless of whether the fundamental or harmonic is used. When a crystal shifts its frequency by two kilocycles, its second harmonic has shifted 4 kilocycles. Amateurs not operating on the edge of the band generally need not concern themselves about frequency drift due to changes in room temperature.

If a pentode or beam tetrode tube having a plate potential of approximately 300 volts is used for the crystal oscillator, the temperature of the crystal, regardless of cut, should not increase enough to cause any noticeable drift even at 14 megacycles. When a crystal oscillator is keyed on 3.5 or 1.7 megacycles, the frequency drift is not of any consequence, even with much higher values of plate input, because of the keying and of the fact that the drift is not multiplied as it would be with harmonic operation of a final amplifier.

The Crystal Holder. Crystal holders have a large effect on the frequency; for example, the frequency of an 80-meter crystal can vary as much as 3 kilocycles in different holders. In fact, crystals can be purchased in variable gap holders which enable the operator to vary the frequency by varying the air gap. From 20 to 50 kc. shift can be obtained at 14 Mc. with the newer types of variable gap crystals.

High-Frequency Crystals. Forty-meter crystals can be treated much the same as 80-meter crystals, provided they are purchased in a dust-proof holder from a reliable manufacturer. However, it is a good idea with 40-meter crystals to make sure that the crystal current is not excessive, as it will run higher in a given oscillator circuit than when a lower frequency crystal is used in the same circuit at the same voltage. A low loss, low C tank circuit and a pentode or beam type oscillator tube are desirable.

Third-Harmonic Crystals (14 and 28 Mc.). Twenty- and 10-meter crystals, especially the latter, require more care in regard to circuit details, components and physical layout. These crystals are *not* of the zero drift type, as such crystals would be too thin to be of practical use. A special thick cut operated on a harmonic (almost always the third) is used to give the crystal sufficient mechanical ruggedness. Crystals of this cut have a drift of approximately 40-45 cycles/Mc./deg. C. This means that such crystals must be run at very low power levels not only to avoid fracture, but to prevent excessive drift. However, their use permits considerable simplification of a u.h.f. transmitter.

A type 41 tube, running at 275 volts on the plate and 100 volts on the screen, makes a good oscillator tube for a 20-meter crystal.

Bias should be obtained from a 500-ohm cathode resistor rather than from a grid leak. Very light loading, preferably with inductive coupling, is required. The tank coil should be low loss, preferably air-supported or wound on a ceramic form.

Medium high μ triodes with high transconductance and low input and output capacities make excellent 10-meter crystal oscillators. The types RK34, 6J5G and 955 are the most satisfactory oscillators, the 6J5G giving the greatest output besides being the least expensive.

Contrary to general practice with pentode crystal oscillators, the plate tank circuit should *not* be too low C; a moderate amount of tuning capacity should be used in a 10-meter triode crystal oscillator. The plate voltage on the oscillator tube should not be allowed to exceed 200 volts. About 2 watts output is obtainable from the 10-meter oscillator tank at this plate voltage. The tank coil can consist of 8 turns of no. 12 wire, air-wound to a 3/4-inch diameter and spaced the diameter of the wire. Bias should be obtained from a 200-ohm cathode resistor (by-passed) and no grid leak. Connecting leads should be short and components small physically.

Both 10- and 20-meter crystal oscillators should be followed, where practicable, by a tube of high power gain, such as the 807. This reduces the number of tubes required in a high power stationary u.h.f. transmitter.

A 10-meter crystal oscillator with a 6J5G, driving a 6V6G doubler using a 150,000-ohm grid leak, makes an excellent 5-meter mobile transmitter. The latter tube can be either plate or plate-and-screen modulated. The modulation is better, especially when doubling, if both plate and screen are modulated.

Crystal Oscillator Circuits

Crystal oscillators can be divided into three classifications: (1) low power circuits, which require several additional buffer stages to drive medium or high power final amplifiers; (2) high power crystal oscillators, which minimize the number of buffer stages in a transmitter; (3) harmonic crystal oscillators, which operate on more than one harmonically related band from one quartz crystal.

Low power crystal oscillators are often required in transmitter design where extremely accurate frequency control is needed. The crystal oscillator tube is operated at low plate potential, such as 200 volts, with the result that oscillation is relatively weak. This means that there will be less heating effect in the quartz plate; the frequency drift, due to

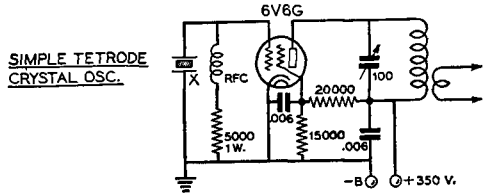

Figure 4.
TYPICAL CRYSTAL OSCILLATOR CIRCUIT.

This circuit has been found to be the most satisfactory for the frequency control of a multi-stage transmitter. A 6L6, or for that matter any pentode or power beam tetrode may be used with comparable success.

changes in temperature, is therefore minimized.

Mere operation of a quartz crystal oscillator tube at relatively low plate voltage does not necessarily mean a low degree of frequency drift; a type of crystal oscillator tube must be used which has high power sensitivity, high μ and low feedback (interelectrode) capacity. The amount of feedback determines the value of r.f. current flowing through the quartz plate and thus determines the amplitude of the physical vibration of the quartz plate. Any tube which requires only a very small amount of grid excitation voltage and has low grid-to-plate capacity can be used to supply relatively high-power output in a crystal oscillator without heating of the quartz plate.

High-power crystal oscillators are those which operate with as high a plate voltage as can be used with only moderate heating of the quartz crystal. Many transmitters, such as those used for amateur work, do not require as high a degree of frequency stability as do radiotelephone transmitters used for commercial services. The relatively high output from such crystal oscillators usually means the elimination of one or two buffer-amplifier stages. This simplifies the transmitter and may result in more trouble-free operation. There are a great many types of tubes suitable for high-power crystal oscillators, some of which are also used in high-stability low-power crystal oscillators by merely reducing the electrode voltages.

The crystal oscillator circuit in figure 4 is the standard oscillator circuit and uses either a pentode or beam tetrode tube. It operates on one frequency only, and the plate circuit is tuned to a frequency somewhat higher than that of the quartz crystal.

The actual power output of a crystal oscillator, such as shown in figure 4, is from one to fifteen watts, depending upon the values of plate and screen voltage. The use of *AT-cut*

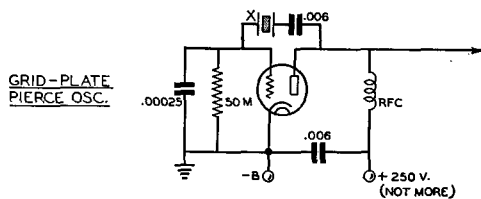

Figure 5.
TYPICAL PIERCE OSCILLATOR CIRCUIT.

No tank circuit is required with this type of crystal oscillator circuit. However, the crystal current is quite high for the amount of output voltage obtained.

or low temperature coefficient quartz plates allows higher values of output to be obtained without exceeding the safe r.f. crystal current ratings or encountering frequency drift. *X-cut* and *Y-cut* crystals, especially the latter, must be operated with comparatively low crystal current because they not only will not stand as much r.f. crystal current, but also have a higher temperature coefficient.

Pierce Crystal Oscillator. One of the earliest crystal oscillator circuits recently enjoyed a revival in popularity. This is the Pierce oscillator, in which the crystal is connected directly from plate to grid of the oscillator tube, the crystal taking the place of the tuned tank circuit in an ultra-audio oscillator. Just as in the ultra-audio, the amount of feedback depends upon the grid to cathode capacity. Thus, it is only necessary to connect from grid to cathode a fixed condenser permitting the proper amount of feedback for the tube and frequency band used. The capacity is not at all critical, and ordinarily it is not necessary to change the capacity even when changing bands.

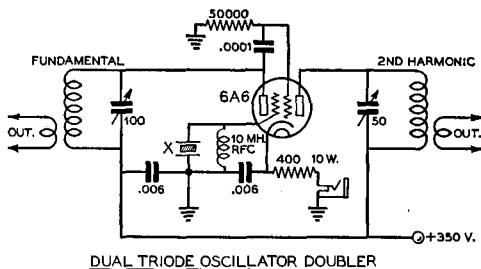

Figure 6.
TYPICAL TWIN-TRIODE OSCILLATOR-DOUBLER CIRCUIT.

Any dual triode of the 7F7, 6N7, 6F8G, 6A6, 53 class may be used in this simple circuit to obtain output on either the crystal frequency or its second harmonic.

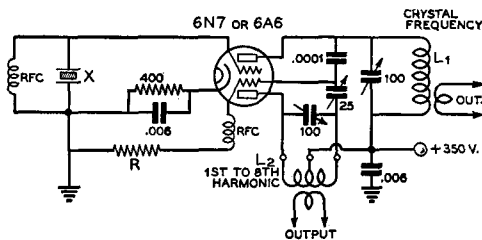

Figure 7.
REGENERATIVE DUAL-TRIODE OSCILLATOR.

By using one section of a dual triode as a crystal oscillator and the other section as a regenerative frequency multiplier, output on frequencies as high as the eighth harmonic of the crystal frequency may be obtained.

The chief advantage of the oscillator is that it requires no tuned circuits. The chief disadvantage is that the maximum obtainable output is low, due to the fact that not over 200-250 volts can be used safely. Also, it works well only with 160- and 80-meter crystals, though many 40-meter crystals will work satisfactorily if the constants are chosen for maximum performance on 40 meters.

The oscillator may be fed plate voltage either through an r.f. choke or a resistor of high enough resistance that it doesn't act as a low impedance path for the r.f. energy. A considerably higher power output can be obtained with an r.f. choke in the plate circuit as compared to the use of a resistor in this position. However, since the plate voltage required on succeeding stages is invariably greater than that used on the Pierce crystal oscillator, the use of a resistor as the plate load is to be recommended. A popular version of the Pierce crystal oscillator circuit is shown in figure 5.

Dual-Triode Oscillator-Doubler Circuits. The types 6N7, 6A6, and 53 twin-triode tubes are popular for circuits where one triode acts as a crystal oscillator which drives the other triode as a frequency doubler; one tube, therefore, serves a dual purpose, supplying approximately 5 watts output on either the fundamental frequency or the second harmonic of the quartz crystal. Two applications of the twin-triode tube in a crystal oscillator circuit are shown in figures 6 and 7.

Figure 6 is a circuit which can be used with quartz crystals cut for 160-, 80-, 40- or 20-meter operation. The circuit shown in figure 7 can be made regenerative in the frequency-multiplier section in order to use the second triode as a tripler or quadrupler. By reducing the capacity of the feedback condenser to a

low enough value, the second triode can be neutralized for use as a buffer stage. A suitable condenser for this purpose is a small mica-insulated trimmer condenser having a capacity range of from 3-to-30 $\mu\mu\text{f}$ s.

The resistor R shown in figure 7 should be from 30,000 to 50,000 ohms in value, and generally the r.f. choke shown in series with this resistor can be omitted.

Harmonic Oscillator Circuits. Harmonic oscillator circuits can be generally defined as those crystal oscillator arrangements which use a single tube and which allow power output to be obtained on harmonics of the crystal frequency. While these oscillator circuits have the advantage that one or more tubes are eliminated from the lineup, and sometimes that a tuned circuit is eliminated, they all have the disadvantage that they are difficult to adjust properly and they all have a tendency toward excessive crystal current when improperly tuned up. Five of the best known and most satisfactory of these oscillator circuits have been grouped together in figure 8.

The Tritet Crystal Oscillator. Any of the common pentode, tetrode, or screen-grid tubes may be used in the tritet crystal oscillator as shown in figure 8A. There are really two active circuits in this oscillator arrangement: the grid-cathode-screen circuit which acts as a triode crystal oscillator, and the cathode-grid-plate circuit which acts as an r.f. amplifier or frequency multiplier with its output circuit shielded from the oscillator portion. The tetrode or pentode plate circuit is *electron coupled* to the oscillator circuit. The plate circuit is generally tuned to the second harmonic and outputs of from 5 to 15 watts can be obtained without damage to the quartz crystal. This circuit is an improvement over the older forms of tritet in which a grid leak was used in place of the grid r.f. choke, and in which no cathode resistor and by-pass condenser were included. The improved circuit (figure 8A) decreases the crystal current as much as 50 per cent, and thereby protects the crystal against fracture. The cathode circuit is high C and is tuned to a frequency which is 40 to 50 per cent higher than that of the crystal. If an 802 or 807 is substituted for the 6L6 tube, the plate circuit can be tuned to the fundamental frequency of the crystal without making it necessary to short-circuit the cathode tuned circuit. A further reduction in r.f. crystal current may be obtained by connecting a 140- $\mu\mu\text{f}$ d. variable condenser between the bottom of the crystal and the top of the cathode tank coil L_2 . This condenser should be set to the smallest value of capacity which will permit steady oscillation and full output.

Regenerative Oscillator Circuits. Figures 8B and 8C show two versions of a regenerative crystal oscillator circuit which requires only one tank circuit and which is capable of giving power output on harmonics of the crystal

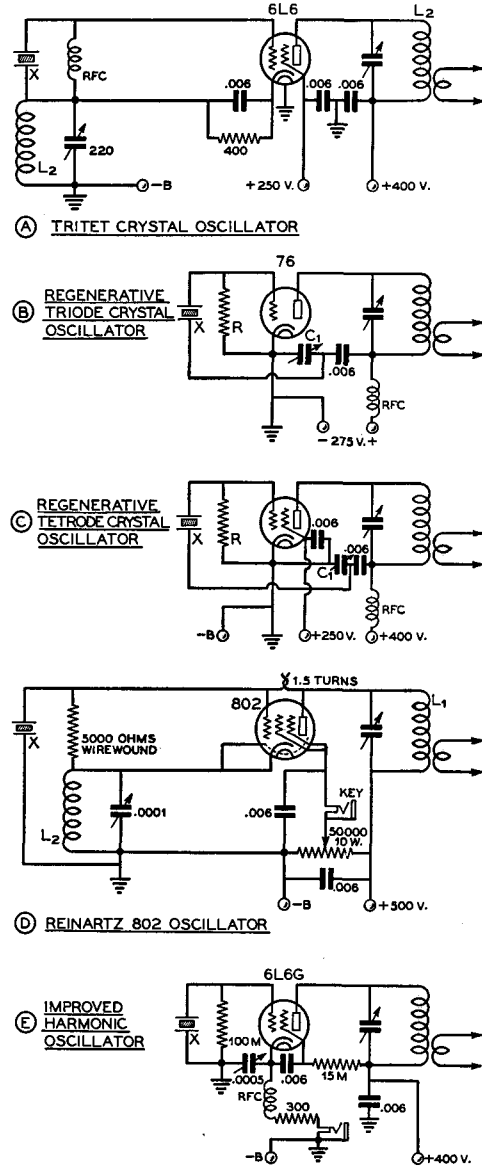

Figure 8. REGENERATIVE OSCILLATOR CIRCUITS. Full details of the operation of these oscillator circuits and a comparison between them is given in the text.

frequency. Figure 8B shows the circuit for use with a triode tube such as the 76, 6C5, 6J5, and 7A4, given in the order of their efficacy. 8C shows the same circuit adapted for use with a pentode or beam tetrode such as the 42, 6F6, 6V6, 6L6, or 7C5.

Triodes such as the 7A4, 6J5-GT, and the 76 will deliver as much as 2 or 3 watts with an r.f. crystal current of between 10 and 60 ma. for crystals from 160 to 10 meters. The triode circuit is excellent to drive a 6L6G buffer-doubler and the screen supply voltage for the 6L6G tube may be applied to the 76 plate circuit. This type of circuit is the only one which works with all crystals, 10, 20, 40, 80 and 160 meters, whether they are extremely active, such as a good X cut, or relatively inactive such as most high-frequency crystals. The triode will furnish from 1 to 2 watts at twice crystal frequency when used with 160-, 80- or 40-meter crystals by tuning the plate circuit to the second harmonic.

In figure 8B the cathode condenser, C_1 , usually is left at some setting of from 40 to 50 $\mu\text{fd.}$ for 40-, 80- and 160-meter crystals.

A 6F6 or 42 works very well in the figure 8C circuit with a C_1 value of .0001 $\mu\text{fd.}$ if heavily loaded. Eight to 12 watts output can be obtained easily from 160 to 20 meters and about 5 watts on 10 meters. A 6L6G tube requires a higher value of C_1 , about .0004 $\mu\text{fd.}$ unless heavily loaded.

Reinartz Crystal Oscillator. The Reinartz 802 crystal oscillator has a fix-tuned cathode circuit which is resonated to approximately *one-half* the crystal frequency. For example, with an 80-meter crystal the cathode circuit is tuned to 160 meters, the plate circuit to 80 meters. Either an 802 or a 6F6 tube can be used in a Reinartz crystal oscillator circuit. The output will be from 5 to 25 watts, depending upon the values of plate and screen voltages. The 6F6 is used as a high- μ triode in this same type of circuit,

whereas the 802 is used as a pentode oscillator with additional control grid-to-plate capacity feedback. The circuit is shown in figure 8D.

The crystal r.f. current is quite low in this circuit, in comparison with the output power which can be obtained. The cathode circuit is tuned to half the frequency of the crystal, and the reactive effect produces regeneration at the harmonic frequency. This increases the operating efficiency of the tube without danger of uncontrollable oscillation at frequencies other than that of the crystal.

Improved Harmonic Oscillator. Figure 8E shows an improved version of a harmonic oscillator arrangement which has been suggested by Jones. It is quite similar to previous arrangements in regard to the general hookup but in this arrangement the screen is by-passed back to the cathode (which is hot to r.f.) rather than to ground. This is said to increase the stability of the oscillator and to increase the efficiency of the arrangement when operating on harmonics of the crystal frequency.

Push-Pull Crystal Oscillators. Figure 9 shows a simple crystal oscillator arrangement which makes use of one of the common dual-triode tubes as a push-pull oscillator. The type 6A6, 6N7, and 7F7 dual triodes make good push-pull crystal oscillators.

Outputs of from 5 to 10 watts can be obtained from this circuit without exceeding the ratings of the usual X-cut crystals. The crystal current for a push-pull oscillator is but little higher than for a single triode of the same type, and twice the output can be obtained.

Some push-pull oscillators will not oscillate on 160 meters, the feedback being insufficient in the push-pull connection to sustain oscillation under load.

Tuning the Crystal Oscillator

In nearly every practical transmitter circuit there will be some means for determining proper tuning of the crystal oscillator stage. Perhaps the most satisfactory of these tuning indicators is the grid milliammeter of the following stage. Maximum meter reading indicates maximum output from the crystal oscillator. Other indicators are: (1) A small neon bulb held near the plate end of the oscillator tuned circuit; maximum glow of the bulb indicates maximum oscillator output. (2) A flashlight bulb or a pilot light bulb, connected in series with a turn of wire fastened to a long piece of wood dowel (to protect the operator) can be coupled to

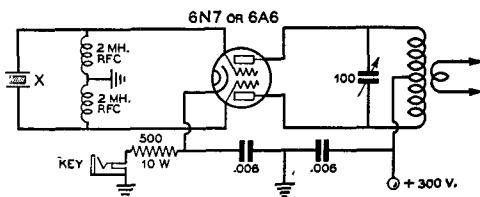

Figure 9.
PUSH-PULL CRYSTAL OSCILLATOR.

Any of the dual-triode tubes make a quite satisfactory push-pull crystal oscillator for feeding a push-pull r.f. amplifier, a push-push doubler, or merely to obtain somewhat greater output than from a single-ended oscillator.

the oscillator coil for indicating r.f. output. Maximum brilliancy of the lamp denotes maximum output from the oscillator.

Oscillator-Doubler Circuits. The type 6N7 or 6A6 oscillator-doubler circuit is adjusted by tuning the oscillator section for maximum output, and the doubler section for greatest dip in cathode or plate current. The crystal plate section should generally be tuned until the circuit approaches the point where oscillation is about to cease; this is towards the higher-capacity setting of the oscillator plate tuning condenser and operation in this manner provides most output in proportion to r.f. crystal current and frequency drift.

Harmonic Oscillators. Harmonic crystal oscillators are always tuned for maximum output and minimum plate, or cathode current. The regeneration or feedback condenser is adjusted or chosen to provide a good plate current dip when the plate circuit is tuned to the second harmonic of the crystal oscillator. Too much regeneration will cause the tube to oscillate for all settings of the plate tank condenser, without any sharp dip at the harmonic frequency of the crystal. Insufficient regeneration will result in low second harmonic output.

A plate potential of 400 volts is generally considered a safe upper limit for a type 6L6 oscillator tube. The screen-grid voltage affects the degree of regeneration and harmonic output; this voltage should generally range between 250 and 275 volts. The cathode current will run between 50 and 60 milliamperes for fundamental frequency operation, and 60 to 75 milliamperes for harmonic operation, at these plate and screen voltages. The crystal r.f. current normally runs between 25 and 75 milliamperes in this type of oscillator, depending on the frequency and plate voltage used.

Radio-Frequency Amplifiers

Since the output of the oscillator stage in a transmitter (whether it be self-controlled or crystal controlled) must be kept down to a fairly low level to maintain stability and to maintain a factor of safety from fracture of the crystal when one is used, the low power output of the oscillator is brought up to the desired power level by means of radio-frequency amplifiers. The two classes of amplifiers that find widest application in amateur transmitters are the class B and class C types.

The Class B Amplifier. Class B amplifiers are used in a radio-telegraph transmitter

when maximum power gain is desired in a particular stage. A class B amplifier operates with cutoff bias and a comparatively small amount of excitation. Power gains of 20 to 200 or so are obtainable in a well-designed class B amplifier. The plate efficiency of a class B c.w. amplifier will run around 65 per cent.

The Class B Linear. Another type of class B amplifier is the class B linear stage as employed in radiophone work. This type of amplifier is used to increase the level of a modulated carrier wave and depends for its operation upon the linear relation between excitation voltage and output voltage. Or, to state the fact in another manner, the power output of a class B linear stage varies linearly with the square of the excitation voltage. The class B linear amplifier is operated with cutoff bias and a small value of excitation, the actual value of exciting power being such that the power output under carrier conditions is one fourth of the peak power capabilities of the stage. Class B linears are very widely employed in broadcast and commercial installations, but are comparatively uncommon in amateur application, since tubes with high plate dissipation are required for moderate output. Another reason for their unpopularity among amateurs is that the power limitation upon amateurs is placed upon power *input* to the final stage and not upon power *output*. The approximately 33 per cent efficiency of the class B linear makes the power capability of a transmitter with a linear amplifier in the final stage less than half that of a high-level modulated transmitter whose maximum efficiency may be as high as 75 or 80 per cent. This assumes, of course, that the maximum legal input of one kilowatt is being employed in each case.

The Class C Amplifier. Class C amplifiers are very widely employed in all types of transmitters. A good power gain may be obtained (values of gain from 3 to 20 are common) and the plate circuit efficiency may be, under certain conditions, as high as 85 per cent. Class C amplifiers operate with considerably more than cutoff bias and ordinarily with a rather large amount of excitation as compared to a class B amplifier. The bias for a normal class C amplifier is such that plate current on the stage flows for approximately 120° of the 360° excitation cycle. Class C amplifiers are used in transmitters where a fairly large amount of excitation power is available, where good plate circuit efficiency is desired, and when the stage is to be plate modulated.

Class C Plate Modulation. The characteristic of a class C amplifier which makes it linear with respect to changes in plate voltage is that which allows such an amplifier to be *plate modulated* for radiotelephony. Through the use of higher bias than is required for a c.w. class C amplifier and greater excitation, the linearity of such an amplifier may be extended from zero plate voltage to twice the normal value. The output power of a class C amplifier adjusted for plate modulation varies with the square of the plate voltage. Since this is the same condition that would take place if a resistor equal to the voltage on the amplifier divided by its plate current were substituted for the amplifier, it is said the stage presents a resistive load to the modulator.

Class C Grid Modulation. If the grid current to a class C amplifier is reduced to a low value and the plate loading is increased to the point where the plate dissipation approaches the rated value, such an amplifier may be grid modulated for radiotelephony. If the plate voltage is raised to quite a high value and the stage is adjusted carefully, efficiencies as high as 42 to 45 per cent with good modulation capability and comparatively low distortion may be obtained. This type of operation is termed class C grid modulation and is coming into increasing favor among amateur radiotelephone operators.

Grid Excitation. A sufficient amount of grid excitation must be available for class B or class C service. The excitation for a plate-modulated class C stage must be sufficient to drive a normal value of d.c. grid current through a grid bias supply of about $2\frac{1}{2}$ times cutoff. The bias voltage preferably should be obtained from a combination of grid leak and fixed C-bias supply. Cutoff bias can be calculated by dividing the amplification factor of the tube into the d.c. plate voltage. This is the value normally used for class B amplifiers (fixed bias, no grid leak). Class C amplifiers use from $1\frac{1}{2}$ to 5 times this value, depending upon the available grid drive, or excitation, and the desired plate efficiency. Less grid excitation is needed for c.w. operation, and the values of fixed bias (if greater than cutoff) may be reduced, or the value of the grid leak resistor can be lowered until normal d.c. grid current flows. This value should be between 75% and 100% of the value listed under tube characteristics.

The values of grid excitation listed for each type of tube may be reduced by as much as 50% if only moderate power output and plate efficiency are desired. When consult-

ing the tube tables, it is well to remember that the power lost in the tuned circuits must be taken into consideration when calculating the available grid drive. At very high frequencies, the r.f. circuit losses may even exceed the power required for grid drive unless low loss tank circuits are used.

Readjustments in the tuning of the oscillator, buffer or doubler circuits, will result in greater grid drive to the final amplifier. The actual grid driving power is proportional to the d.c. voltage developed across the grid leak (or bias supply) multiplied by the d.c. grid current.

Link coupling between stages, particularly to the final amplifier grid circuit, normally will provide more grid drive than can be obtained from other coupling systems. The number of turns in the coupling link and the location of the turns on the coil can be varied with respect to the tuned circuits to obtain the greatest grid drive for allowable values of buffer or doubler plate current. Slight readjustments sometimes can be made after plate voltage has been applied.

Excessive grid current will damage the tubes by overheating the grid structure; beyond a certain point of grid drive no increase in power output can be obtained for a given plate voltage.

Neutralization of R. F. Amplifiers

The plate-to-grid feedback capacity of triodes makes it necessary that they be neutralized for operation as r.f. amplifiers at frequencies above about 500 kc. Those screen-grid tubes, pentodes, and beam tetrodes which have a plate-to-grid capacity of a small fraction of one micro-microfarad may ordinarily be operated as an amplifier without neutralization.

Neutralizing Circuits. The object of a neutralization circuit for an r.f. amplifier is, of course, to cancel or "neutralize" the capacitive feedback of energy from plate to grid. There are two general methods by which this energy feedback may be eliminated: the first, and the most common method, is through the use of a capacity bridge, and the second method is through the use of a parallel reactance of equal and opposite polarity to the grid-to-plate capacity to nullify the effect of this capacity.

Until recently, the capacity-bridge method of neutralization was divided into two systems, grid neutralization and plate neutralization. It has always been known that the use of grid neutralization caused an amplifier to be either regenerative or degenerative,

but it was not until quite recently that Doherty showed the reason for the unsatisfactory performance of grid neutralization. Hence, only plate neutralization (the capacity bridge system), and coil neutralization (the opposite reactance system) will be considered as satisfactory methods for neutralizing a single-ended r.f. amplifier stage.

Tapped-Coil Plate Neutralization. As was mentioned under *Neutralizing Circuits*, there are two general types of neutralizing circuits for a single-ended amplifier, the bridge and opposite-reactance methods. The following paragraphs will describe first the variations upon the bridge method. Figure 10A shows a circuit for the neutralization of a single-ended triode r.f. amplifier by means of a tapped coil in the plate circuit. This circuit is satisfactory for frequencies below about 7 Mc. with ordinary tubes but a considerable amount of regeneration will be found when this circuit is used on frequencies above 7 Mc. Some regeneration can be tolerated in an amplifier for c.w. use, but for phone operation either of the split-stator circuits described in the next two paragraphs should be used.

Split-Stator Plate Neutralization. Figure 10B shows the neutralization circuit which is most widely used in single-ended r.f. stages. The use of a split-stator plate condenser makes the electrical balance of the circuit substantially independent of the mutual coupling within the coil and also makes the balance independent of the place where the coil is tapped. With conventional tubes this circuit will allow one neutralization adjustment to be made on, say, 14 Mc., and this adjustment will hold for all lower frequency bands.

Capacity-Balanced Split-Stator Plate Neutralization. Figure 10C shows an alternative circuit for split-stator neutralization of a single-ended amplifier stage which, with low-capacity tubes, can be made to remain in adjustment on all bands from 56 Mc. on down in frequency. The additional balancing condenser CB serves merely as an adjustment to keep the capacity-to-ground exactly the same from each side of the balanced plate tank circuit. This condenser can be either a small adjustable one of the type commonly used for neutralization, or the relative capacity to ground of the two sides of the circuit can be proportioned so that there is a balance. In determining the balance of the circuit, it must be remembered that the plate-to-filament capacity of the power amplifier tube is the main item to cause the unbalance. If the other capacities

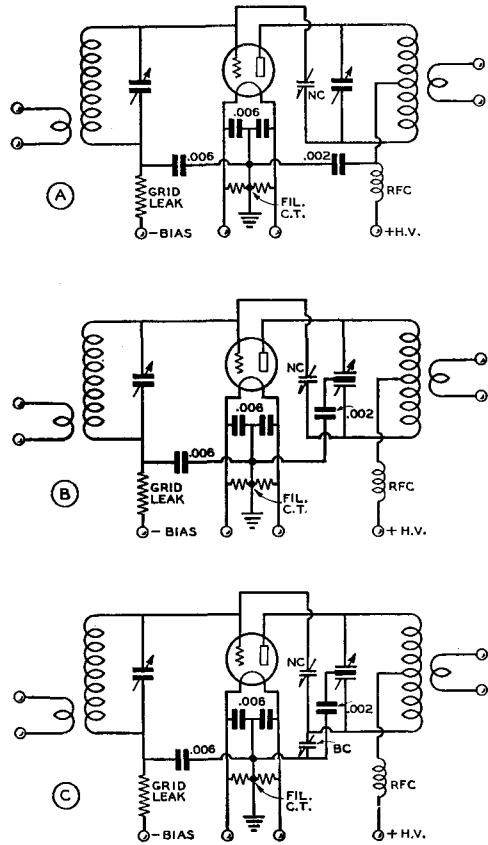

Figure 10.
PLATE NEUTRALIZING CIRCUITS FOR
A SINGLE-ENDED AMPLIFIER.

(A) shows a neutralizing circuit employing a split coil plate tank which is suitable under ordinary conditions for operation at frequencies as high as 7 Mc. (B) shows conventional split-stator plate neutralization. (C) shows split-stator plate neutralization with the addition of a balancing condenser BC which compensates for the plate-to-ground capacity of the amplifier tube and thus keeps the output tank circuit balanced to ground, improving neutralization on the higher frequencies.

of the circuit are perfectly balanced with respect to ground, the capacity of the condenser CB should be approximately equal to the plate-to-ground capacity of the tube being neutralized. However, it is often just as convenient to unbalance the circuit capacities to ground until the additional capacity on the neutralizing side of the circuit is about equal to that on the plate side. At the point where the plate-to-ground capacity is exactly

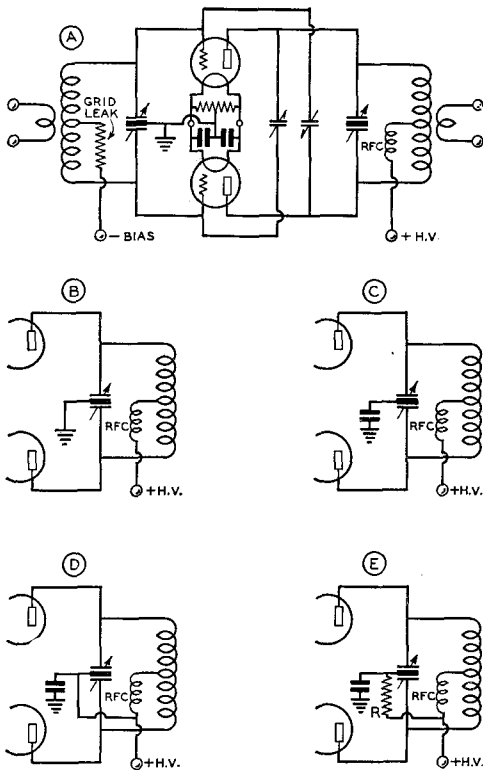

Figure 11.
PUSH-PULL AMPLIFIER NEUTRALIZATION.

(A) shows the basic circuit for a neutralized push-pull r.f. amplifier. In this circuit the nodal point for the stage is determined by the grounded rotor on the grid tuning condenser and the rotor of the plate tank condenser is allowed to float. (B), (C), (D), and (E) show alternative arrangements for returning the rotor of the plate tank condenser to ground when this grounding is deemed necessary. Discussion of the various circuits is given in the text.

balanced the amplifier will neutralize perfectly (at least as nearly perfect as a push-pull amplifier) and will stay neutralized on all bands for which the amplifier tubes are satisfactory.

Push-Pull Neutralization. Two tubes can be connected for *push-pull* operation so as to obtain twice as much output as that of a single tube. A push-pull amplifier, such as that shown in figure 11A, also has an advantage in that the circuit can more easily be balanced than a single-tube r.f. amplifier. The various interelectrode capacities and the

neutralizing condensers are connected in such a manner that those on one side of the tuned circuits are exactly equal to those on the opposite side. For this reason, push-pull r.f. amplifiers can be more easily neutralized in very-high-frequency transmitters; also, they usually remain in perfect neutralization when tuning the amplifier to different bands.

The circuit shown in figure 11A is perhaps the most commonly used arrangement for a push-pull r.f. amplifier stage. The rotor of the grid condenser is grounded and the rotor of the plate tank condenser is allowed to float. Under certain conditions the circuit of 11B may be used (when the plate tank condenser has a much larger voltage rating than the maximum possible peak output of the power tubes) with the rotor of the grid condenser grounded or not, as desired. It is also possible to use a single-section grid condenser with a tapped coil (un-bypassed) for low-frequency operation with this circuit arrangement.

Figure 11C shows an alternative arrangement for the return of the rotor of the plate tank condenser which is best for use with a c.w. amplifier stage. The by-pass condenser from the rotor to ground can be any capacity from $.01 \mu\text{fd.}$ down to $.0005 \mu\text{fd.}$ and even down to $.0001 \mu\text{fd.}$ for a u.h.f. amplifier. For phone use it is best to have some sort of a coupling arrangement to make the rotor of the tuning condenser follow plate voltage fluctuations. As long as the rotor of the tuning condenser is at the same d.c. potential as the stators there will be a much reduced chance of breakdown on modulation peaks.

Figures 11D and 11E show two arrangements which tend to keep the rotor of the condenser as nearly as possible at the same d.c. potential as the stators. In figure 11D the rotor of the condenser, and the ungrounded side of the by-pass condenser, is merely connected to the plate supply side of the r.f. choke. This is an excellent arrangement for use with moderate plate voltages but has the disadvantage that considerable stress is placed on the mica by-pass condenser, and should this condenser break down the plate supply would be shorted. Figure 11E shows an alternative arrangement which has the advantage that, should the mica by-pass condenser short out, only the resistor R will be destroyed. For a mica by-pass capacity of $.001 \mu\text{fd.}$ and a maximum 100 per cent modulation frequency of 3000 cycles, a 25,000-ohm resistor will be satisfactory for R.

Shunt Neutralization. The feedback of energy from grid to plate that would cause

oscillation or serious regeneration in an unneutralized r.f. amplifier is a result of the grid-to-plate capacity of the amplifier tube. A neutralization circuit is merely an electrical arrangement for nullifying the effect of this capacity. All the previous neutralization circuits have made use of a bridge circuit for balancing out the grid-to-plate energy feedback by an amount of energy equal and opposite in phase from a balanced tuned circuit.

Another method of eliminating the feedback effect of this capacity, and hence of neutralizing the amplifier stage, is shown in figure 12. The grid-to-plate capacity in the triode amplifier tube acts as a capacitive reactance coupling energy back from the plate to the grid circuit. If we parallel this capacity with an inductance having the same value of reactance (but having the opposite sign, of course) at the frequency upon which the amplifier is operating, the reactance of one will cancel the reactance of the other and we will have a high-impedance tuned circuit from grid to plate on the triode tube.

This neutralization circuit works very beautifully and can be used on ultra-high frequencies where other neutralization circuits are unsatisfactory. This is true because the lead length in the neutralization circuit is practically negligible. The circuit can also be used with push-pull r.f. amplifiers; in this case each tube is neutralized separately although both neutralizing condensers are set to the same capacity.

The big advantage of this arrangement is that it allows the use of single-ended tank circuits with a single-ended amplifier.

However, the circuit has one serious disadvantage for amateur work in which the frequency of operation is changed frequently: the neutralization holds for one frequency—that frequency where the grid-to-plate capacity is resonant with the external neutralization coil. But by the use of plug-in coils and the trimmer condenser C in parallel with the grid-to-plate capacity, it is possible to shift the band of operation and to trim to any frequency within the band. This trimmer condenser, if used, must be insulated for somewhat more voltage than the tank condenser. The .0001- μ f. condenser in series with the neutralizing circuit is merely a blocking condenser to isolate the plate voltage from the grid circuit. The coil L will have to have a very large number of turns for the band in operation in order to be resonant with the usually rather small grid-to-plate capacity. But since, in all or-

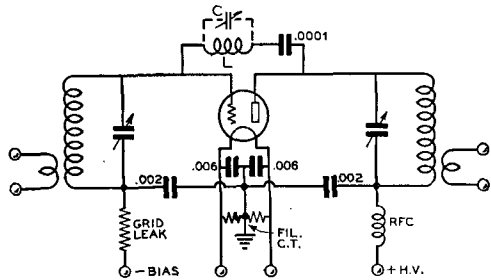

Figure 12.

SHUNT OR "COIL" NEUTRALIZATION.

This neutralization circuit makes use of a coil connected from grid to plate (with a blocking condenser in series with it) which resonates with the grid-to-plate capacity to the operating frequency. The impedance from plate to grid is thus made very high, feedback is stopped, and the amplifier is neutralized for this frequency of operation. When the frequency of operation is changed, the trimmer condenser C changes the resonant frequency of this circuit to the new operation frequency.

Figure 13.

ALTERNATIVE SHUNT NEUTRALIZATION CIRCUIT.

In this circuit the trimmer condenser for varying the frequency of resonance of the circuit is placed in series with the neutralizing coil, thus replacing the blocking condenser and reducing the necessary voltage rating for the trimmer condenser, although increasing the capacity required.

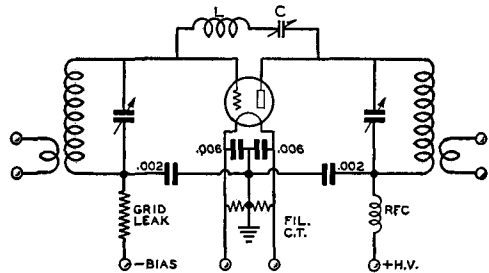

inary cases with tubes operating on frequencies for which they were designed, the L/C ratio of the tuned circuit will be very high, the coil can use comparatively small wire although it must be wound on air or very low-loss dielectric and must be insulated for the sum of the plate r.f. voltage and the grid r.f. voltage.

Figure 13 shows an alternative arrangement for the neutralizing circuit in which the variable trimmer condenser is in series with the neutralizing coil instead of in parallel

with it. This system also allows the stage to be trimmed to neutralization on any frequency in the band of operation. This condenser can have a capacity of 35 to 100 μfd . and need not have nearly as much voltage insulation as the trimmer condenser shown in figure 12. A plate spacing of .070" will be ample for any plate voltage ordinarily used by the amateur.

Neutralizing Procedure

The r.f. amplifier is neutralized to prevent self-oscillation or regeneration. A neon bulb, a flashlight lamp and a loop of wire, or an r.f. galvanometer can be used as a *null indicator* for neutralizing low-power stages. Plate voltage is disconnected from the r.f. amplifier stage while it is being neutralized. Normal grid drive then is applied to the r.f. stage, the neutralizing indicator is coupled to the plate coil and the plate tuning condenser is tuned to resonance. The neutralizing condenser (or condensers) then can be adjusted until *minimum* r.f. is indicated for resonant settings of both grid and plate tuning condensers. Both neutralizing condensers are adjusted simultaneously and to approximately the same value of capacity when a push-pull stage is being neutralized.

A final check for neutralization should be made with a d.c. milliammeter connected in the grid leak or grid-bias circuit. There will be no movement of the meter reading as the plate circuit is tuned through resonance (without plate voltage being applied) when the stage is completely neutralized. The milliammeter check is more accurate than any other means for indicating complete neutralization and it also is suitable for neutralizing the stages of a high-power transmitter.

Push-pull circuits usually can be more completely neutralized than single-ended circuits when operating at very high frequencies. In the intermediate range of from 3 to 15 megacycles, single-ended circuits will give satisfactory results. Single-ended operation in the 3-to-15 megacycle range is most stable with split-stator tuning condensers.

Neutralizing Problems. When a stage cannot be completely neutralized, the difficulty can be traced to one or more of the following causes: (1) The filament leads may not be by-passed to the common ground bus connection of that particular stage. (2) The ground lead from the rotor connection of the split-stator tuning condenser to filament may be too long. (3) The neutralizing condensers may be in a field of excessive r.f. from one

of the tuning coils. (4) Electromagnetic coupling may exist between grid and plate coils, or between plate and preceding buffer or oscillator circuits. (5) Insufficient shielding or spacing between stages, or between grid and plate circuits in compact transmitters may prevent neutralization or give false indications of neutralizing adjustments. (6) If shielding is placed too close to plate circuit coils, neutralization will not be secured because of induced currents in the shields. (7) Parasitic oscillations may take place when plate voltage is applied. The cure for the latter is mainly a matter of cut and try—rearrange the parts, change the length of grid or plate or neutralizing leads, insert an ultra-high-frequency r.f. choke in the grid lead or leads, or eliminate the grid r.f. chokes which may be the cause of a low-frequency parasitic (in conjunction with plate r.f. chokes).

Plate Circuit Tuning. When the amplifier is completely neutralized, reduced plate voltage should be applied before any load is coupled to the amplifier. This reduction in plate voltage should be at least 50% of normal value because the plate current will rise to excessive values when the plate tuning condenser is not adjusted to the point of resonance. The latter is indicated by the greatest dip in reading of the d.c. plate current milliammeter; the r.f. voltage across the plate circuit is greatest at this point. With no load, the r.f. voltage may be several times as high as when operating under conditions of full load; this may result in condenser flashover if normal d.c. voltage is applied. The no-load plate current at resonance should dip to 10% or 20% of normal value. If the plate circuit losses are excessive, or if *parasitic oscillations* are taking place, the no-load plate current will be higher.

Loading. The load (antenna or succeeding r.f. stage) then can be coupled to the amplifier under test. The coupling can be increased until the plate current at resonance (greatest dip in plate current meter reading) approaches the normal values for which the tube is rated. The value at reduced plate voltage should be proportionately less in order to prevent excessive plate current load when normal plate voltage is applied. Full plate voltage should not be applied to an amplifier unless the r.f. load also is connected; otherwise the condensers will arc or flash over, thereby causing an abnormally high plate current which may damage the tube. The tuned circuit impedance is lowered when the amplifier is loaded, as are the r.f. voltages across the plate condenser.

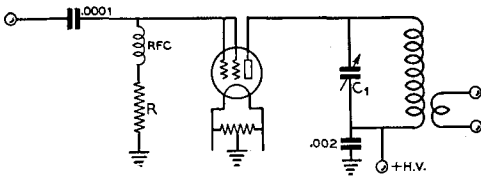

Figure 14.
CONVENTIONAL FREQUENCY DOUBLER
CIRCUIT.

A high- μ , dual-grid triode, or a pentode or beam tetrode with the grid and screen paralleled makes an excellent frequency doubler. In addition, all of these types of tubes have the advantage that when the excitation is removed their plate current will fall to a very low value. The plate circuit is tuned to twice the excitation frequency.

doubler can be excited from a crystal oscillator, or connected to another doubler or buffer amplifier stage.

Doubling is best accomplished by operating the tube with extremely high grid bias in order to make the output plate current rich in harmonics. The grid circuit is driven approximately to the normal value of d.c. grid current through the r.f. choke and grid leak resistor, shown in figure 14. The resistance value generally is from two to five times as high as that used with the same tube for simple amplification. For the same value of grid current the grid bias is several times as high.

Neutralization is seldom absolutely necessary in a doubler circuit, since the plate is

Grid Excitation. Excessive grid excitation is just as injurious to a vacuum tube as abnormal plate current or low filament voltage. Too much grid driving power will overheat the grid wires in the tube, and will cause a release of gas in certain types of tubes. An excess of grid drive will not appreciably increase the power output and increases the efficiency only slightly after a certain point is reached. The grid current in the tube should not exceed the values listed in the *Tube Tables*, and care also should be exercised to have the bias voltage low enough to prevent flashover in the stem of the vacuum tube.

Grid excitation usually refers to the actual r.f. power input to the grid circuit of the vacuum tube, part of which is used to drive the tube, and part of which is lost in the C-bias supply. There is no way to avoid wasting a portion of the excitation power in the bias supply.

Frequency Multipliers

Quartz crystals are not ordinarily used for direct control of the output of high-frequency transmitters. *Frequency multipliers* are needed to multiply the frequency to the desired value. These multipliers operate on exact multiples of the crystal frequency; a 3.6-megacycle crystal oscillator can be made to control the output of the transmitter on 7.2 or 14.4 megacycles, or even on 28.8 megacycles, by means of one or more frequency multipliers. When used at twice frequency, as they most usually are, they are often termed *frequency doublers*. A simple doubler circuit is shown in figure 14. It consists of a vacuum tube with its plate circuit tuned to *twice* the frequency of the grid driving circuit. This

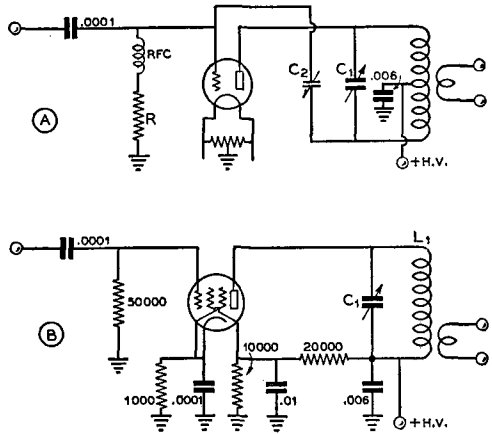

Figure 15.
REGENERATIVE DOUBLER CIRCUITS.

(A) shows a circuit which may be used either as a neutralized buffer stage or, when the capacity of C_2 is increased beyond the "neutralized" setting, as a regenerative doubler. (B) shows a frequency multiplier circuit with cathode regeneration which will give quite good results as a doubler, and very good results, compared to other multiplier circuits, as a frequency quadrupler.

tuned to twice the frequency of the grid circuit. The feedback from the doubler plate circuit to the grid circuit is at *twice* the frequency of the grid driving circuit to which the coupling condenser (figure 14) is connected. The impedance of this external tuned grid driving circuit is very low at the doubling frequency and thus there is no tendency for self-excited oscillation when ordinary triode tubes are used. At very high frequencies however, this impedance may be great enough to cause

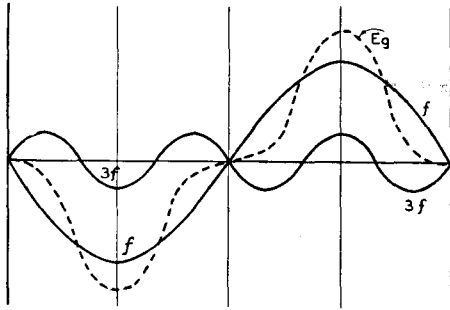

Figure 16.

PEAKED WAVEFORM OBTAINED BY ADDITION OF FUNDAMENTAL AND THIRD-HARMONIC ENERGY IN PROPER PHASE.

When fundamental frequency (f) energy and third-harmonic ($3f$) energy are added in the proper phase the result is a peaked waveform as shown by E_g . This peaked waveform, when used as excitation for a frequency doubler stage, gives considerably higher plate efficiency than when sine-wave excitation voltage is applied to the grid of the tube.

regeneration, or even oscillation, at the tuned output frequency of the doubler.

A doubler can either be neutralized or made more regenerative by adjusting C_2 in the circuit shown in figure 15.

When condenser C_2 is of the proper value to neutralize the plate-to-grid capacity of the tube, the plate circuit can be tuned to twice the frequency (or to the same frequency) as that of the source of grid drive; the tube can be operated either as a neutralized amplifier or doubler. The capacity of C_2 can be increased so that the doubler will become *regenerative*, if the r.f. impedance of the external grid driving circuit is high enough at the output frequency of the stage.

Frequency doublers require bias of several times cutoff; high- μ tubes therefore are desirable for this type of service. Tubes which have amplification factors from 20 to 200 are suitable for doubler circuits. Tetrodes and pentodes usually have high amplification constants of from 3 to 10, are not applicable for doubler service because in some cases the grid voltage must be as high as the plate voltage for efficient doubling action. The necessary d.c. grid voltage for high- μ tubes can be obtained more easily from average driver stages in conventional exciters.

Angle of Flow in Frequency Multipliers.

The angle of plate current flow in a frequency multiplier is a very important factor in de-

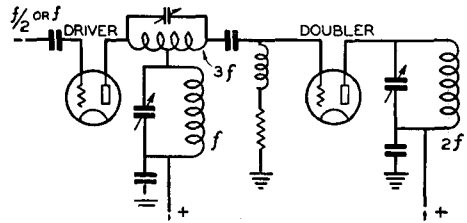

Figure 17.

CIRCUIT FOR COMBINING FUNDAMENTAL AND THIRD-HARMONIC ENERGY IN PROPER PHASE FOR PEAKED WAVEFORM.

The small third-harmonic tank circuit connected as shown adds the fundamental and third harmonic in the proper phase relation for producing a peaked excitation waveform on the grid of the doubler stage.

termining the efficiency. As the angle of flow is decreased for a given value of grid current, the efficiency increases. To reduce the angle of flow, higher grid bias is required so that the grid excitation voltage will exceed the cutoff value for a shorter portion of the exciting-voltage cycle. Frequency doublers of all types should have an angle of flow of 90 degrees or less, triplers 60 degrees or less and quadruplers 45 degrees or less.

Normally, a smaller angle of flow requires quite high bias and excitation. However, by altering the shape of the exciting voltage from its usual sine wave shape at the exciting frequency, it is possible to decrease the angle of flow and thus increase the efficiency without resorting to increases in the excitation voltage and bias.

The angle of flow may be decreased by adding some properly phased third harmonic voltage to the excitation. The result of adding the third harmonic voltage to the fundamental is shown graphically in figure 16. As shown by the dotted curve, E_g , when the fundamental and third harmonic voltages are added in the proper phase the result is a grid excitation voltage having a peaked wave form, exactly what is required for high-efficiency frequency multiplying. The method by which the third harmonic is added is shown in figure 17. A small, center-tapped tank circuit tuned to three times the driver frequency is placed between the driver plate and the coupling condenser to the frequency-multiplier stage. The center tap of this coil is connected to the "hot" end of the driver plate tank, which remains tuned to the fundamental frequency. The third-harmonic tank circuit can be tuned ac-

curately to frequency by coupling to it a small, low-current dial lamp in a loop of wire and tuning for maximum brilliancy. An absorption wavemeter may be coupled to the third-harmonic tank after it has been tuned to make sure that it is on the correct harmonic. The tuning of this circuit is not critical; one setting will serve to cover an amateur band.

Push-Push Doublers. Two tubes can be connected with the grids in push-pull, and the plates in parallel, for operation in a so-called *push-push doubler*, as shown in figure 18.

This doubler circuit will deliver twice as much output as a single-tube circuit; it has proven popular in amateur transmitters because of its operating ease. In previous doubler circuits, capacitive coupling was shown. Link coupling to the tuned circuit in a preceding stage is shown in figure 18. This coupling arrangement simplifies the push-pull connection of the two grid circuits.

The circuit C_2-L_2 is tuned to the same frequency as that of the preceding tuned circuit, and the doubler plate circuit C_1-L_1 is tuned to *twice* the frequency. The grid circuit should be tuned by means of a split-stator condenser, connected as shown in figure 18, rather than by means of the single-section tuning condenser and by-passed center-tapped coil arrangement. The latter would provide a relatively high impedance at the doubling frequency. The push-push doubler then would be highly regenerative, and in most cases it would break into self-oscillation. The split-stator tuning circuit, because it has a capacitive reactance, provides a very low impedance at the doubling frequency, so that there is very little regenerative action; the circuit, therefore, is quite stable if the grid tank is not made too low C.

Some multigrad crystal oscillators are designed so that frequency doubling can be accomplished directly in the oscillator tube circuit by connecting the various grids in push-pull (2 tubes) and the output plates in parallel.

The push-push circuit makes a very efficient doubling arrangement because each grid is being excited on a positive half of the exciting voltage and, since the grids are in push-pull, this means that plate current flows to one or the other of the parallel plates twice during every cycle of the exciting voltage. Thus the current pulses in the plate circuit occur at twice the exciting-voltage frequency, resulting in extremely efficient doubling action. The push-push doubler may also be used as a quadrupler by tuning the plate circuit to the fourth harmonic of the

grid-excitation frequency. As with a single ended doubler, short-pulse excitation is required for good efficiency.

Tank Circuit Capacities

Tuning capacity values for class C amplifiers are an important consideration to anyone building a radio transmitter. The best value of capacity can be determined closely by charts or formulas for any frequency of operation. The ratio of C to L, capacitance to inductance, depends upon the operating plate voltage and current, and upon the type of circuit. Proper choice of capacity-to-inductance ratio for resonance at any given frequency is important in obtaining low harmonic output and also low distortion in the case of a modulated class C amplifier.

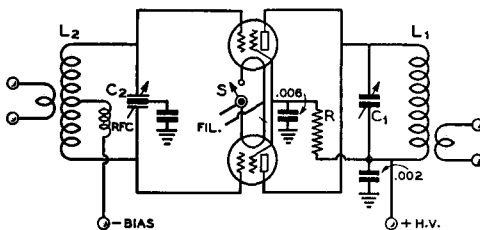

Figure 18.

PUSH-PUSH DOUBLER CIRCUIT.

In this type of doubler the grids are connected in push-pull and the plates are connected in parallel. A pair of triodes, a dual triode, or a pair of pentodes or tetrodes may be used. In the diagram shown, the heater of one of the tubes may be opened and the other tube operated as a neutralized amplifier, the other tube acting as the neutralizing condenser.

A class C amplifier produces a very distorted plate current wave form in the form of pulses as shown in figure 19. The LC circuit is tuned to resonance and its purpose is to smooth out these pulses into a sine wave of radio-frequency output, since any wave form distortion of the carrier frequency is illegal, causing harmonic interference in higher-frequency channels. A class A radio-frequency amplifier would produce a sine wave output. However, the a.c. plate current would be flowing during the full 360° of each r.f. cycle, resulting in excessive plate loss in the tube for any reasonable value of output. The class C amplifier has a.c. plate current flowing during only a fraction of each cycle, allowing the plate to cool off dur-

ing the remainder of each cycle. If the plate current is zero for 2/3 of each cycle, the angle of plate current flow is said to be 120° , since current is flowing during 1/3 of 360° . The tube in a class C amplifier could have several times as much power input for a given plate loss as when used in a class A amplifier.

The tuned circuit must have a good fly-wheel effect in order to furnish a sine-wave output to the antenna when it is receiving energy in the form of very distorted pulses such as shown in figure 19. The LC circuit fills in power over the complete r.f. cycle, providing the LC ratio is correct. The fly-wheel effect is generally defined as the ratio of radio-frequency volt-amperes to actual power output, or VA/W . This is equivalent

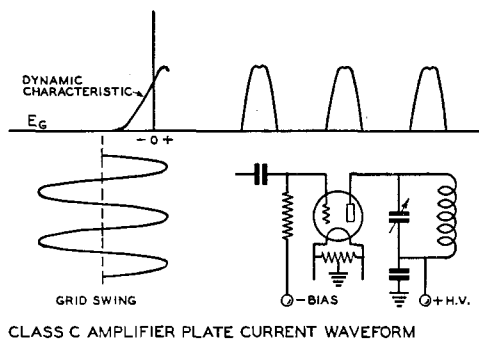

Figure 19.

to Q and should not be much less than 4π , or 12.5, for a class-C amplifier. At this value of VA/W or Q , one-half of the stored energy in the LC circuit is absorbed by the antenna. If a lower value of Q is used, the storage power is insufficient to produce a sine (undistorted) wave output to the antenna and power will be wasted in radiation of harmonics.

Too high a value of VA/W or Q will result in excessive circulating r.f. current loss in the LC circuit and lowered output to the antenna. In high-fidelity radiophone transmitters, too high a Q will cause attenuation of the higher sideband frequencies and consequent loss of the higher audio frequencies. Too low a Q has its disadvantages also; so most transmitters are operated with LC circuit values of between 10 and 25. A value of 20 seems to be high enough for modulated class C amplifiers; about 10 to 12 is enough

for c.w. transmitters. With values of Q less than about 10, the maximum r.f. output will not occur at the point of minimum plate current in the amplifier tuning adjustment.

Harmonic Radiation vs. Q . Opinions vary as to the correct value of Q , but a careful analysis of the whole problem seems to indicate that a value of 12 is suitable for most amateur phone or c.w. transmitters. A value of 15 to 20 will result in less harmonic radiation at the expense of a little additional heat power loss in the tank or LC circuit. The charts shown have been calculated for an operating value of $Q = 12$.

The curves shown in figure 20 indicate the sharp increase in harmonic output into the antenna circuit for low values of Q . The curve for the second harmonic rises nearly

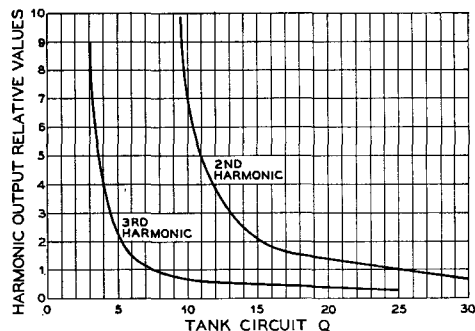

Figure 20.

SECOND AND THIRD HARMONIC OUTPUT PLOTTED AGAINST TANK CIRCUIT Q .

vertically for Q values of less than 10. The third harmonic does not become seriously large for values of Q less than 4 or 5. These curves show that push-pull amplifiers may be operated at lower values of Q if necessary, since the second harmonic is cancelled to a large extent if there is no capacitive or unbalanced coupling between the tank circuit and the antenna feeder system.

Effect of Loading on Q . The Q of a circuit depends upon the resistance in series with the capacitance and inductance. This series resistance is very low for a low-loss coil not loaded by an antenna circuit. The value of Q may be from 100 to 200 under these conditions. Coupling an antenna circuit has the effect of increasing the series resistance, though in this case the power is

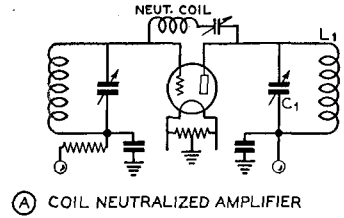
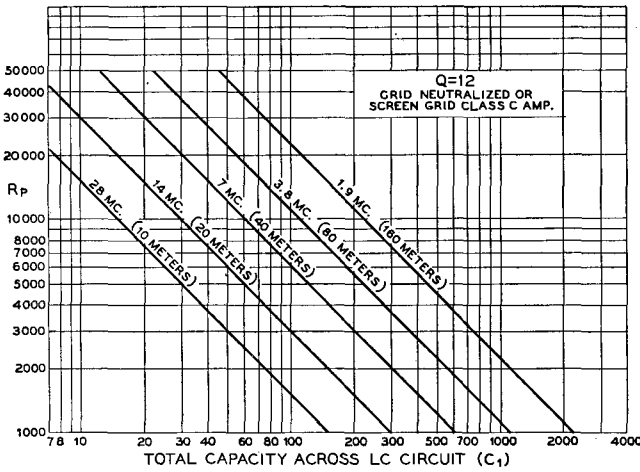

Figure 21.

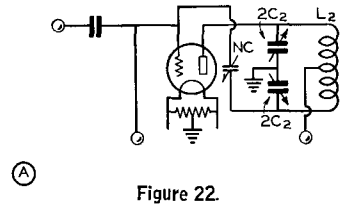
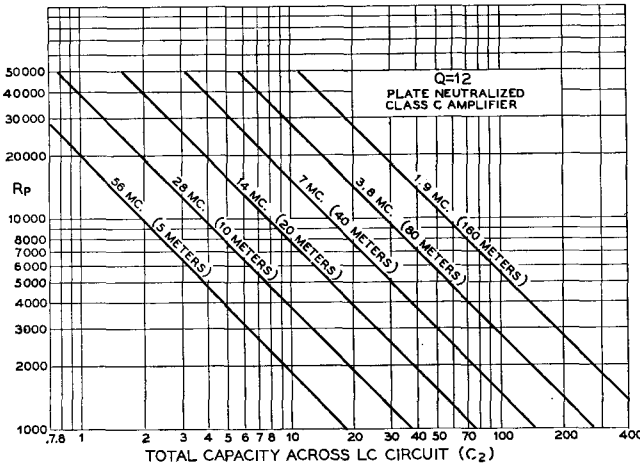
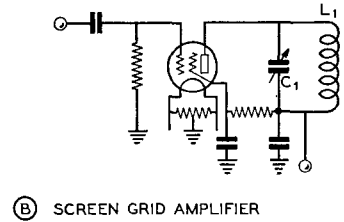

Figure 22.

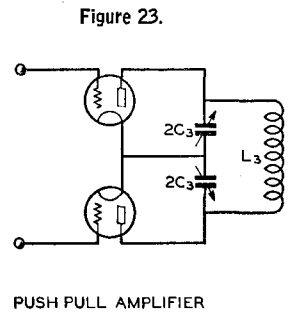
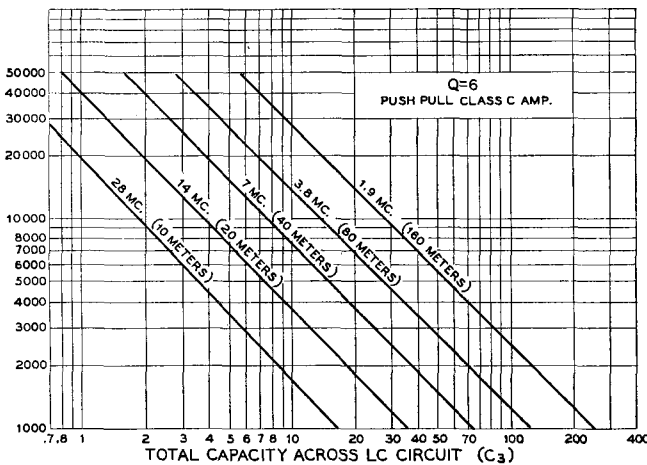
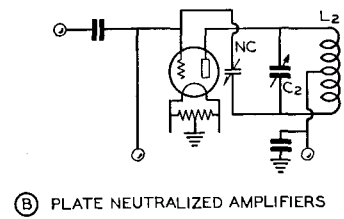

Figure 23.

consumed as useful radiation by the antenna. Mathematically, the antenna increases the value of R in the expression $Q = \omega L/R$ where L is the coil inductance and ω is the term $2\pi f$, f being in cycles per second.

The antenna coupling can be varied to obtain any value of Q from 3 to values as high as 100 or 200. However, the value of $Q = 12$ (or $Q = 20$ if desired) will not be obtained at normal values of d.c. plate current in the class C amplifier tube unless the C-to-L ratio in the tank circuit is correct for that frequency of operation.

The values of C_1 , C_2 and C_3 shown in figures 21, 22 and 23 are for the total capacity across the inductance. This includes the tube inter-electrode capacities, distributed coil capacity,

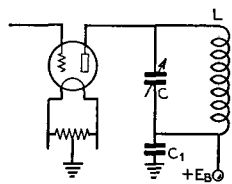

Figure 24.

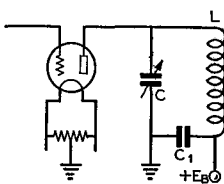

Figure 25.

wiring capacities and tuning condenser capacity. If a split-stator condenser is used, the effective capacity is equal to half of the value of each section since the two sections are in series across the tuned circuit. The total stray capacities range from approximately 2 up to 30 $\mu\mu\text{fd.}$ and largely depend upon the type of tube or tubes used in the class C amplifier.

In the push-pull circuit of figure 23, each tube works on a portion of each half cycle so less storage or flywheel effect is needed and a value of $Q = 6$ may be used instead of $Q = 12$.

The values of R_p are easily calculated by dividing the d.c. plate supply voltage by the total d.c. plate current (expressed in amperes). Correct values of total tuning capacity are shown in the charts for the different amateur bands. The shunt stray capacity can be estimated closely enough for all practical purposes. The coil inductance should then be chosen which will produce resonance at the desired frequency with the total calculated tuning capacity.

The capacities shown are the minimum recommended values and they should be increased 50% to 100% for modulated class C

amplifiers where economically feasible. The values shown in the charts are sufficient for c.w. operation of class C amplifiers. It is again emphasized that these values are *total capacities* across the tank circuit, and should not be considered as the capacity *per section* for a *split-stator* condenser. If a split-stator condenser is to be used, the *per section* capacity should be *twice* that indicated by the charts.

Tuning Condenser Air Gap

Plate-Spacing Requirements for Various Circuits and Plate Voltages. In determining condenser air gaps the peak r.f. voltage impressed across the condenser is the im-

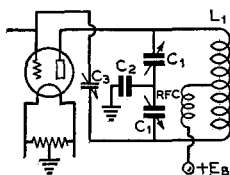

Figure 26.

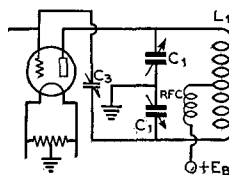

Figure 27.

portant item, since the experimental and practical curves of air gap versus peak volts as published by the Allen D. Cardwell Mfg. Corp. may be applied to any condenser with polished plates having rounded edges. Typical peak breakdown voltages for corresponding air gaps are listed in the table. These values can be used in any circuit. The problem is to find the peak r.f. voltage in each case and this can be done quite easily.

The r.f. voltage in the plate circuit of a class C amplifier tube varies from nearly zero to twice the d.c. plate voltage. If the d.c. voltage is being 100 per cent modulated by an audio voltage, the r.f. peaks will reach four times the d.c. voltage. These are the highest values reached in any type of loaded amplifier: a class B linear, class C grid- or plate-modulated or class C c.w. amplifier. The circuits shown in figures 25 and 27 require a tuning condenser with plate spacing which will have an r.f. peak breakdown rating at least equal to 2 times or 4 times the d.c. plate voltage for c.w. and plate-modulated amplifiers respectively.

It is possible to reduce the air gap to one-half by connecting the amplifier so that the d.c. plate voltage does not appear across the

tuning condenser. This is done in figures 24 and 26. These circuits should always be used in preference to those of figures 25 and 27 since the tuning condenser is only about one-fourth as large physically for the same capacity. Consequently, it is proportionately less expensive.

The peak r.f. voltage of a plate-modulated class C amplifier varies at 100% modulation from nearly zero to four times E_b , the d.c. plate voltage, but only one-half of this voltage is applied across the tuning condensers of figures 24 and 26. For a class B linear, class C grid-modulated or c.w. amplifier, the r.f. voltage across the tube varies from nearly zero up to twice E_b . The r.f. voltage is an a.c. voltage varying from zero to a positive and then to a negative maximum over each cycle. The fixed (mica) condenser C_1 in figure 24, and C_2 in figure 26 insulates the rotor from d.c. and allows us to subtract the d.c. voltage value from the tube peak r.f. voltage value in calculating the breakdown voltage to be expected.

This gives us a simple rule to follow for a normally-loaded plate-modulated r.f. amplifier. The peak voltage across the tuning condenser C or C_1 of figures 24 and 26 respectively will be *twice the d.c. plate voltage*. If a single-section condenser is used in figure 26, with the by-pass condenser C_2 connected to the coil center tap, the plate spacing or air gap must be twice as great as that of a split-stator condenser; so there is no appreciable saving in costs for a given capacity.

In c.w. amplifiers the air gap must be great enough to withstand a peak r.f. voltage *equal to the d.c. plate voltage*, for each section C_1 of figure 26, or, C of figure 26.

These rules apply to a loaded amplifier or buffer stage. If the latter is ever operated

without an r.f. load, the peak voltages may be very much greater—by as much as two or three times in ordinary LC circuits. For this reason no amplifier should be operated without load when anywhere near normal d.c. plate voltage is applied.

A factor of safety in the air-gap rating should be applied to insure freedom from r.f. flashover. This is especially true when using the circuits of figures 25 and 27; in these circuits the plate supply is shorted when a flashover occurs. Knowing the peak r.f. voltage, an air gap should be chosen which will be about 100% greater than the breakdown rating. The air gaps listed will break down at the approximate peak voltages in the table. If the circuits are of the form shown in figures 25 and 27, the peak voltages across the condensers will be nearly twice as high and twice as large an air gap is needed. The fixed condensers, usually of the mica type, shown in figures 24 and 26, must be rated to withstand the d.c. plate voltage plus any audio voltage. This condenser should be rated at a d.c. working voltage of at least *twice the d.c. plate supply in a plate modulated amplifier* and at least *equal to the d.c. supply* in any other type of r.f. amplifier.

Push-Pull Stages. The circuits of figures 26 and 27 apply without any change in calculations to push-pull amplifiers. Only one tube is supplying power to the tuned circuit at any given instant, each one driving a part of each half cycle. The different value of Q and increased power output increase the peak voltages slightly but for all practical purposes, the same calculation rules may be employed.

These rules are based on average amateur design for any form of r.f. amplifier

AIR-GAP IN INCHES	PEAK VOLTAGE BREAKDOWN
.030	750
.050	1500
.070	3000
.078	3500
.084	3800
.100	4150
.144	5000
.175	5700
.200	6200
.250	7200
.300	8200
.350	9250
.375	10,000
.500	12,000

D.C. PLATE VOLTAGE	C. W.	PLATE MOD.
400	.030	.050
600	.050	.070
750	.050	.100
1000	.070	.084
1250	.070	.144
1500	.078	.200
2000	.100	.250
2500	.175	.375
3000	.200	.500
3500	.250	.600

with a recommended factor of safety of 100% to prevent flashover in the condenser. This is sufficient for operation into normal loads at all times, providing there are no freak parasitic oscillations present. The latter sometimes cause flashover across air gaps which should ordinarily stand several times the normal peak r.f. voltages. This is especially true of low-frequency parasitics.

The actual peak voltage values of a stable, loaded r.f. amplifier are somewhat less than the calculations indicate, which gives an additional factor of safety in the design.

Parasitic Oscillation in R.F. Amplifiers

Parasitics are undesirable oscillations either of very high or very low frequencies which occur in radio-frequency amplifiers.

They may cause additional signals (which are often rough in tone), other than normal harmonics, hash on each side of a modulated carrier, key clicks, voltage breakdown or flashover, instability or inefficiency, and shortened life or failure of the tubes. They may be damped and stop by themselves after keying or on modulation cycles, or they may be undamped and built up during ordinary unmodulated transmission, continuing if the excitation is removed. They may be at audio or radio frequency, in either type of amplifier (though only the r.f. amplifier is treated in this discussion). They may result from series or parallel resonant circuits of all types including the dynatron. Due to the neutralizing lead length or the nature of most parasitic circuits, the amplifier usually is not neutralized for the parasitic frequency.

Sometimes the fact that the plate supply is keyed obscures parasitic oscillations that might be very severe if the plate voltage were left on and only the excitation removed.

In some cases, an all-wave receiver will prove helpful in finding out if the amplifier is without spurious oscillations, but it may be necessary to check from one meter on up, to be perfectly sure. A normal harmonic is weaker than the fundamental but of good tone; a strong harmonic or a rough note at any frequency generally indicates trouble.

Low-Frequency Parasitics. One type of unwanted oscillation often occurs in shunt-fed circuits in which the grid and plate chokes resonate, coupled through the tube's inter-electrode capacity. It can also happen with series feed. This oscillation is generally at a lower frequency than the desired one and causes additional carriers to appear, spaced from twenty to a few hundred kilocycles on either side of the main wave. One cure is to

change the type of feed in either the grid or plate circuit or to eliminate one choke. Another is to use much less inductance in the grid choke than in the plate choke, or to replace the grid choke by a wire-wound resistor if the grid is series fed. In a class C stage with grid-leak bias, no r.f. choke is required if the bias is series fed.

This type of parasitic may take place in push-pull circuits, in which case the tubes are effectively in parallel for the parasitic and the neutralization is not effective. The grids or plates can be connected together without affecting the undesired oscillation; this is a simple test for this type of parasitic oscillation.

Parallel Tubes. A very high frequency inter-tube oscillation often occurs when tubes are operated in parallel. Noninductive damping resistors or manufactured parasitic suppressors in the grid circuit, or short inter-connecting grid leads together with small plate choke coils, very likely will prove helpful.

Tapped Inductances. When capacity coupling is used between stages, particularly when one of the stages is tapped down from the end of the coil, additional parasitic circuits are formed because of the multiple resonant effects of this complex circuit. Inductive or link coupling permits making adjustments without forming these undesired circuits. Likewise, a condenser tapped across only part of an inductance, for bandspread tuning or capacity loading, makes the situation more complex.

Multi-Element Tubes. Screen-grid, pentode, and beam tetrode tubes may help to eliminate parasitic circuits by using no neutralization, but their high gain occasionally makes parasitic oscillation easy, particularly when some form of input-output coupling exists. Furthermore, the by-pass circuit from the additional elements to the filament must be short and effective, particularly at the higher frequencies, to prevent undesired internal coupling. At the high frequencies, a variable screen by-pass condenser at some settings may improve the internal shielding without causing a new parasitic oscillation. A blocking (relaxation) effect may occur if the screen is fed through a series resistor. The screen circuit can, of course, act as the plate in a tuned-grid tuned-plate oscillation that can be detuned or damped at the control grid terminal.

Crystal Stages. Crystal oscillators are seldom suspected of parasitic oscillation troubles, but are often guilty. Ordinary as well as parasitic circuit coupling between the

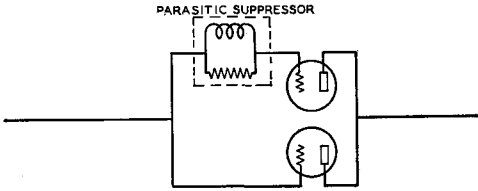

Figure 28.

Showing the use of a parasitic suppressor in series with one grid of a pair of paralleled tubes. In a push-pull amplifier which develops parasitics, the parasitic suppressor can be connected in series with the lead from the grid tank circuit to the grid of one of the tubes.

grid and plate circuits should be held to a minimum by separating or shielding the grid and plate leads, and by reducing the area of the loop from the grid through the crystal holder to the filament. Keeping the grid circuit short, even adding a small choke coil of a few turns in the plate lead next to the tube, will probably eliminate the possibility of high-voltage series-tuned parasitics.

Parasitic Suppressors. The most common type of parasitic is of the u.h.f. type, which fortunately can usually be dampened by inserting a parasitic suppressor of the type illustrated in figure 28 in the grid lead, or in one grid lead of either a push-pull or parallel tube amplifier.

Grid Bias

Radio-frequency amplifiers require some form of *grid bias* for proper operation. Practically all r.f. amplifiers operate in such a manner that plate current flows in the form of short peaked impulses which have a duration of only a fraction of an r.f. cycle. The plate current is cut off during the greater part of the r.f. cycle, which makes for high efficiency and high power output from the tubes, since there is no power being dissipated by the plates during a major portion of each r.f. cycle. The grid bias must be sufficient to cut off the plate current, and in very high efficiency class C amplifiers this bias may be several times the cutoff value. Cutoff bias, it will be recalled, is that value of grid voltage which will reduce the plate current to zero, and the method for calculating it has been indicated previously. This theoretical value of cutoff will not reduce the plate current completely to zero, due to the variable- μ tendency which is characteristic of all tubes as the cutoff point is approached. This

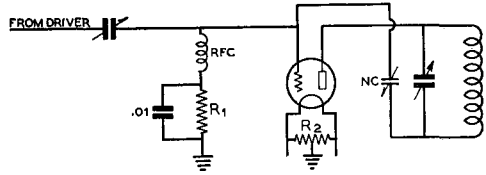

Figure 29.
GRID LEAK BIASED STAGE.

Showing how a resistor may be connected in series with the grid return lead to obtain bias due to the flow of rectified grid current through the resistor.

factor, however, is of no importance in practical applications.

Class C Bias. Radiophone class C amplifiers should be operated with the grid bias adjusted to values between two and three times cutoff at normal values of d.c. grid current to permit linear operation (necessary when the stage is plate-modulated). C.w. telegraph transmitters can be operated with bias as low as cutoff, if limited excitation is available and high plate efficiency is not a factor. In a c.w. transmitter, the bias supply or resistor should be adjusted to the point which will allow normal grid current to flow for the particular amount of grid driving r.f. power available. This form of adjustment will allow more output from the under-excited r.f. amplifier than when twice cutoff, or higher bias is used with low values of grid current.

Grid-Leak Bias. A resistor can be connected in the grid circuit of an r.f. amplifier to provide grid-leak bias. This resistor R_1 in figure 29 is part of the d.c. path in the grid circuit.

The r.f. excitation is applied to the grid circuit of the tube. This causes a pulsating d.c. current to flow through the bias supply lead and any current flowing through R_1 produces a voltage drop across that resistance. The grid of the tube is positive for a short duration of each r.f. cycle, and draws electrons from the filament or cathode of the tube during that time. These electrons complete the circuit through the d.c. *grid return*. The voltage drop across the resistance in the grid return provides a *negative bias* for the grid. The r.f. chokes in figures 29, 30, 31, and 32 prevent the r.f. excitation from flowing through the bias supply, or from being short-circuited to ground. The by-pass condenser across the bias source proper is for the purpose of providing a low impedance path for the small amount of stray r.f. energy which passes through the r.f. choke.

Grid-leak bias automatically adjusts itself even with fairly wide variations of r.f. excitation. The value of grid-leak resistance should be such that normal values of grid current will flow at the maximum available amount of r.f. excitation. Grid-leak bias cannot be used for grid-modulated or linear amplifiers in which the average d.c. grid current is constantly varying with modulation.

Grid-leak bias alone provides no protection against excessive plate current in case of failure of the crystal oscillator, or failure of any other source of r.f. grid excitation. A C-battery or C-bias supply can be connected in series with the grid leak, as shown in figure 30. This additional C-bias should at least be made equal to cutoff bias. This will protect the tube in the event of failure of grid excitation.

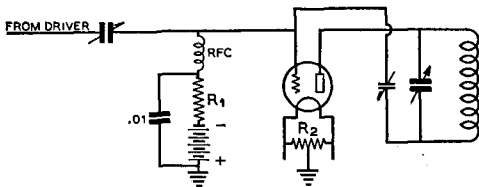

Figure 30.
GRID LEAK AND BATTERY BIAS.
A battery may be added to the grid-leak bias system of figure 30 to provide protection in case of excitation failure.

Cathode Bias. A resistor can be connected in series with the cathode or center-tapped filament lead of an amplifier to secure *automatic bias*. The plate current flows through this resistor, then back to the cathode or filament, and the voltage drop across the resistor can be applied to the grid circuit by connecting the grid bias lead to the grounded, or power supply end of the resistance R, as shown in figure 31.

The grounded (B-minus) end of the cathode resistor is negative relative to the filament by an amount equal to the voltage drop across the resistor. The value of resistance must be so chosen that the desired plate current flowing through the resistor will bias the tube for proper operation at that plate current.

This type of bias is used more extensively in audio-frequency than in radio-frequency amplifiers. The voltage drop across the resistor must be subtracted from the total plate supply voltage when calculating the power in-

put to the amplifier, and this loss of plate voltage in an r.f. amplifier may be excessive. A class A audio amplifier is biased only to approximately one-half cutoff, whereas an r.f. amplifier may be biased to twice cutoff, or more, and thus the plate supply voltage loss may be a large percentage of the total available voltage when using low- or medium- μ tubes.

Separate Bias Supply. C-batteries or an external C-bias supply sometimes are used for grid bias of an amplifier, as shown in figure 32.

Battery bias gives very good voltage regulation and is satisfactory for grid-modulated or linear amplifiers, which operate nearly at zero grid current. In the case of class C amplifiers which operate with high grid current, battery bias is not very satisfactory.

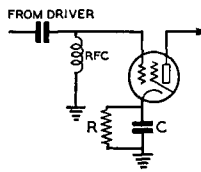

CATHODE BIAS
FIGURE 31

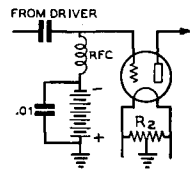

BATTERY BIAS
FIGURE 32

A resistor in the cathode lead gives cathode, or "automatic" bias as shown in figure 31. The voltage drop across the cathode resistor due to the flow of plate and grid current is applied to the grid in the form of negative bias. Figure 32 shows the use of a battery only as bias—this arrangement is suitable only for stages which do not draw over about 15 ma. of grid current.

This d.c. current has a charging effect on the dry batteries; after a few months of service the cells will become unstable, bloated and noisy.

A separate a.c. operated power supply can be used as a substitute for dry batteries. The bleeder resistance across the output of the filter can be made sufficiently low in value that the grid current of the amplifier will not appreciably change the amount of negative grid-bias voltage. This type of bias supply is used in class B audio and class B r.f. linear amplifier service where the voltage regulation in the C-bias supply is important. For a class C amplifier it is not so important, and an economical design of components in the power supply therefore can be utilized. However, in a class C application the bias voltage must be adjusted with normal grid current flowing as the grid current will raise

the bias when it is flowing through the bias-supply bleeder resistance.

Interstage Coupling

Energy can be coupled from one circuit in a transmitter into another in the following ways: *capacitive coupling*, *inductive coupling* or *link coupling*. The latter is a special form of inductive coupling. The choice of a coupling method depends upon the purpose for which it is to be used.

Capacitive Coupling. Capacitive coupling between an amplifier or doubler circuit and a preceding driver stage is shown in figure 33.

The coupling condenser, C, isolates the d.c. plate supply from the next grid and provides a low impedance path from the r.f. energy be-

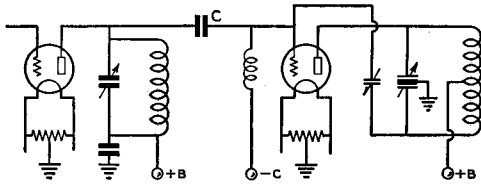

Figure 33.
CAPACITIVE INTERSTAGE COUPLING.

tween the tube being driven and the driver tube. This method of coupling is simple and economical for low-power amplifier or exciter stages, but has certain disadvantages. The grid leads in an amplifier should be as short as possible, but this is difficult to attain in the physical arrangement of a high-power amplifier with respect to a capacitively-coupled driver stage.

Disadvantages of Capacity Coupling. The r.f. choke in series with the C-bias supply lead must offer an extremely high impedance to the r.f. circuit, and this is difficult to obtain when the transmitter is operated on several harmonically related bands. Another disadvantage of capacitive coupling is the difficulty of adjusting the load on the driver stage. Impedance adjustment can be accomplished by tapping the coupling lead a part of the way down on the plate coil of the tuned stage of the driver circuit. However, when this lead is tapped part way down on the coil, a *parasitic oscillation* tendency becomes very troublesome and is difficult to eliminate. If the driver stage has sufficient power output

so that an impedance mismatch can be tolerated, the condenser C in figure 33 can be connected directly to the top of the coil, and made small enough in capacity for the particular frequency of operation that not more than normal plate current is drawn by the driver stage.

The grid circuit impedance of a class C amplifier may be as low as a few hundred ohms in the case of a high- μ tube, and may range from that value up to a few thousand ohms for low- μ tubes.

Capacitive coupling places the grid-to-filament capacity of the driven tube directly across the driver tuned circuit, which reduces the LC ratio and sometimes makes the r.f. amplifier difficult to neutralize because the additional driver stage circuit capacities are connected into the grid circuit. Difficulties

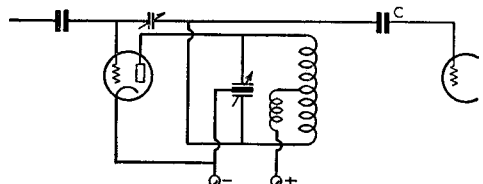

Figure 34.
BALANCED CAPACITIVE COUPLING.

This type of capacitive interstage coupling helps to equalize the capacities across the two sides of the driver tank circuit.

from this source can be partially eliminated by using a center-tapped or split-stator tank circuit in the plate of the driver stage and capacity coupling to the opposite end from the plate. This method places the plate-to-filament capacity of the driver across one half of the tank and the grid-to-filament capacity of the following stage across the other half. This type of coupling is shown in figure 34.

Capacitive coupling can be used to advantage in reducing the total number of tuned circuits in a transmitter so as to conserve space and cost. It also can be used to advantage between stages for driving tetrode or pentode amplifier or doubler stages. These tubes require relatively small amounts of grid excitation.

Inductive Coupling. The r.f. amplifier often is coupled to the antenna circuit by means of *inductive coupling*, which consists of two coils electromagnetically coupled to each other. The antenna tuned circuit can be of the series-tuned type, such as is illus-

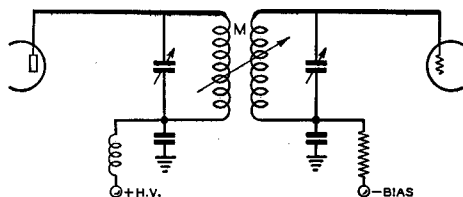

Figure 35.
INDUCTIVE INTERSTAGE COUPLING.

trated for *Marconi*-type 160-meter antennas in the chapter on *Antennas*. Parallel resonant circuits sometimes are used, as shown in figure 35, in which the antenna feeders are connected across the whole or part of the secondary circuit.

The degree of coupling is controlled by varying the mutual inductance of the two coils, which is accomplished by changing the spacing between the coils.

Inductive coupling also is used extensively for coupling r.f. amplifiers in radio receivers, and occasionally in transmitting r.f. amplifier circuits. The mechanical problems involved in adjusting the degree of coupling in a transmitter make this system of limited practical value.

Link Coupling. A special form of inductive coupling which is applied to radio transmitter circuits is known as *link coupling*. A low impedance r.f. transmission line, commonly known as a *link*, couples the two tuned circuits together. Each end of the line is terminated in one or more turns of wire, or *loops*, wound around the coils which are being coupled together. These loops should be coupled to each tuned circuit at the point of zero r.f. potential. This *nodal* point is the center of the tuned circuit in the case of plate-neutralized or push-pull amplifiers, and at the positive-B end of the tuned circuit in the case of screen grid and grid-neutralized amplifiers.

The nodal point in an antenna tuned circuit depends upon the type of feeders, and the node may be either at the center or at one end of the tuned circuit.

The nodal point in tuned grid circuits is at the C-bias or grounded end of plate-neutralized or screen-grid r.f. amplifiers, and at the center of the tuned grid coil in the case of push-pull or grid-neutralized amplifiers. The link coupling turns should be as close to the nodal point as possible. A ground connection to one side of the link is used in special cases where harmonic elimination is important, or where capacitive coupling between two circuits must be minimized.

Typical link coupled circuits are shown in figures 36 and 37.

Some of the advantages of link coupling are listed here:

- (1) It eliminates coupling taps on tuned circuits.
- (2) It permits the use of series power supply connections in both tuned grid and tuned plate circuits, and thereby eliminates the need of r.f. chokes.
- (3) It allows separation between transmitter stages of distances up to several feet without appreciable r.f. losses.

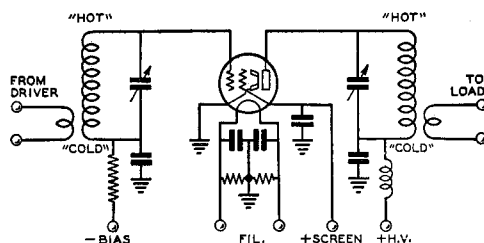
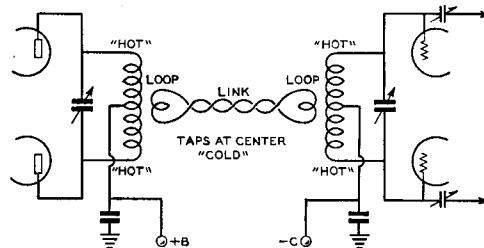

Figure 36.
LINK COUPLED CIRCUIT.

Showing link coupling into and out of a single-ended beam-tetrode amplifier stage. The coupling links should be placed at the "cold" or low-potential ends of the grid and plate coils.

Figure 37.
PUSH-PULL LINK COUPLING.

When link coupling is used between push-pull stages or between "split" tank circuits, the coupling loops are placed at the center of the coils.



- (4) It reduces capacitive coupling and thereby makes neutralization more easily attainable in r.f. amplifiers.
- (5) It provides semiautomatic impedance matching between plate and grid tuned circuits, with the result that greater grid swing can be obtained in comparison to capacitive coupling.
- (6) It effectively reduces harmonic radiation when a final amplifier is coupled to a

tuned antenna circuit, due to the additional tuned circuit and, particularly, it eliminates capacitive coupling to the antenna.

The link coupling line and loops can be made of no. 18 or 20 gauge push back wire for coupling low-power stages. High-power circuits can be link-coupled by means of no. 8 to no. 12 rubber-covered wire, twisted low-impedance antenna-feeder wire, concentric lines or open-wire lines of no. 12 or no. 14 wire spaced 1/4 to 1/2 inch.

The impedance of a link coupling line varies from 75 to 200 ohms, depending upon the diameter of the conductors and the spacing between them.

Radio-Frequency Chokes

Radio-frequency chokes are connected in circuits for the purpose of preventing r.f. energy from being short-circuited, or escap-

band would not be satisfactory for operation in the 40-meter band. The harmonic resonance points of the r.f. choke usually are made to fall between frequency bands, so that a reasonably high value of impedance is obtained on all amateur bands. The d.c. current which flows through the r.f. choke largely determines the size of wire to be used in the windings. The inductance of r.f. chokes for very short wave-lengths is much less than for chokes designed for broadcast and ordinary short-wave operation, so that the impedance will be as high as possible in the desired range of operation. A very high inductance r.f. choke has more distributed capacity than a smaller one, with the result that it will actually offer less impedance at very high frequencies.

Shunt and Series Feed. Direct-current grid and plate connections are made either by *series* or *parallel feed* systems. Simplified forms of each are shown in figures 38 and 39.

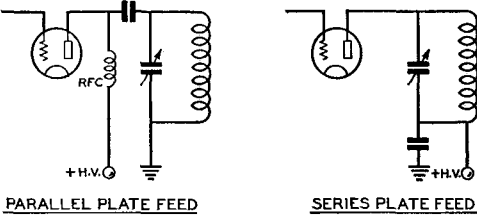

Figure 38.

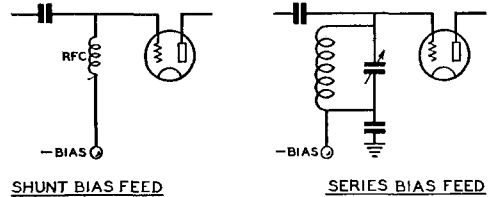

Figure 39.

ing into power supply circuits. They consist of inductances wound with a large number of turns, either in the form of a solenoid or universal pie-winding. These inductances are designed to have as much inductance and as little distributed or shunt capacity as possible, since the capacity by-passes r.f. energy. The unavoidable small amount of distributed capacity resonates the inductance, and this frequency normally should be lower than the frequency at which the transmitter or receiver circuit is operating. R.f. chokes for operation on several harmonically related bands must be designed carefully so that the impedance of the choke will be extremely high (several hundred thousand ohms) in each of the bands.

The r.f. choke is resonant to the harmonics of its fundamental resonant frequency; however, the *even* harmonics have a very low impedance, so that an r.f. choke designed for maximum impedance in the 80-meter amateur

Series feed can be defined as that in which the d.c. connection is made to the grid or plate circuit at a point of very low r.f. potential. Shunt feed always is made to a point of high r.f. voltage and always requires a high impedance r.f. choke or resistance in the connection to the high r.f. point to prevent loss of r.f. power.

Parallel and Push-Pull Tube Circuits

The comparative r.f. power output from parallel or push-pull operated amplifiers is the same if proper impedance matching is accomplished, if sufficient grid excitation is available in both cases, and if the frequency of measurement is considerably lower than the frequency limit of the tubes.

Parallel Operation. Operating tubes in parallel has some advantages in transmitters designed for operation on 40, 80 and 160 meters, or for broadcast band operation.

Only one neutralizing condenser is required for parallel operation, as against two for push-pull. However, on wavelengths below 40 meters, parallel tube operation is not advisable because of the unbalance in capacity across the tank circuits. Low-C types of vacuum tubes can be connected in parallel with less difficulty than the high-C types, in which the combined interelectrode capacities might be quite high in the parallel connection.

Push-Pull Operation. The push-pull connection provides a well-balanced circuit insofar as miscellaneous capacities are concerned; in addition the circuit can be neutralized more easily, especially in high-frequency amplifiers. The L/C ratio in a push-pull amplifier can be made higher than in a plate-neutralized parallel-tube operated amplifier. Push-pull amplifiers, when perfectly balanced, have less second-harmonic output than parallel or single-tube amplifiers. In actual practice, undesired capacitive coupling and circuit unbalance tend to offset the theoretical harmonic-reducing advantage of push-pull r.f. circuits.

Transmitter Keying

The carrier frequency signal from a c.w. transmitter must be broken into dots and dashes in the form of *keying* for the transmission of code characters. The carrier signal is of a constant amplitude while the key is closed, and is entirely removed when the key is open. If the change from the no-output condition to *full-output* occurs too rapidly, an undesired *key-click* effect takes place which causes interference in other signal channels. If the opposite condition of full output to no output condition occurs too rapidly, a similar effect takes place.

Excitation or Plate Voltage Keying. The two general methods of keying a c.w. transmitter are those which control either the excitation, or the plate voltage which is applied to the final amplifier. Plate voltage control can be obtained by connecting the key in the primary line circuit of the high voltage plate power supply. A slight modification of direct plate voltage control is the connection of the c.w. key or relay in the filament center-tap lead of the final amplifier. *Excitation keying* can be of several forms, such as crystal oscillator keying, buffer stage keying or blocked-grid keying.

Key Clicks. Key clicks should be eliminated in all c.w. telegraph transmitters. Their elimination is accomplished by preventing a too-rapid make-and-break of power to the

antenna circuit. A gradual application of power to the antenna, and a similarly slow cessation, will eliminate key clicks. Too much lag will prevent fast keying, but fortunately key clicks can be practically eliminated without limiting the speed of manual (hand) keying. Some circuits which eliminate key clicks introduce too much time-lag and thereby add *tails* to the dots. These tails may cause the signals to be difficult to copy at high speeds.

Click Filters. Eliminating key clicks by some of the key-click filter circuits illustrated in the following text is not certain with every individual transmitter. The constants in the time-lag and spark-producing circuits depend upon the individual characteristics of the transmitter, such as the type of filter, power input and various circuit impedances. All keying systems have one or more disadvantages, so that no particular method can be recommended as an ideal one. An intelligent choice can be made by the reader for his particular transmitter requirements by carefully analyzing the various keying circuits.

Primary Keying. Key clicks (except those arising from arcing at the key, which usually do not carry beyond a few hundred feet) can be eliminated entirely by means of primary keying, in which the key is placed in the a.c. line supply to the primary of the high voltage plate supply transformer. This method of keying also has the advantage that grid leak bias can be used in the keyed stages of the transmitter. As ordinarily applied, the plate voltage to the final amplifier is controlled by the action of the key. The filter in the high voltage rectifier circuit creates a time-lag in the application and removal of the d.c. power input to the r.f. amplifier. Too much filter will introduce too great a time lag, and add tails to the dots. If a high-power stage is keyed, the variation in load on the house-lighting circuits may be sufficient to cause blinking of the lights. A heavy-duty key or keying relay is necessary for moderate or high-power transmitters to break the inductive a.c. load of the power supply. The exciting current or surge current may be several times as high as the average current drawn by the transformer which is being keyed. This will cause difficulty from sticking key contacts or burnt points on the keying relay. This effect can be minimized by proper design of the power transformer, which should have a high primary inductance and an iron core of generous size.

Lag-Less Primary Keying Circuit. An improved primary keying circuit is shown in figure 40. This circuit makes high speed key-

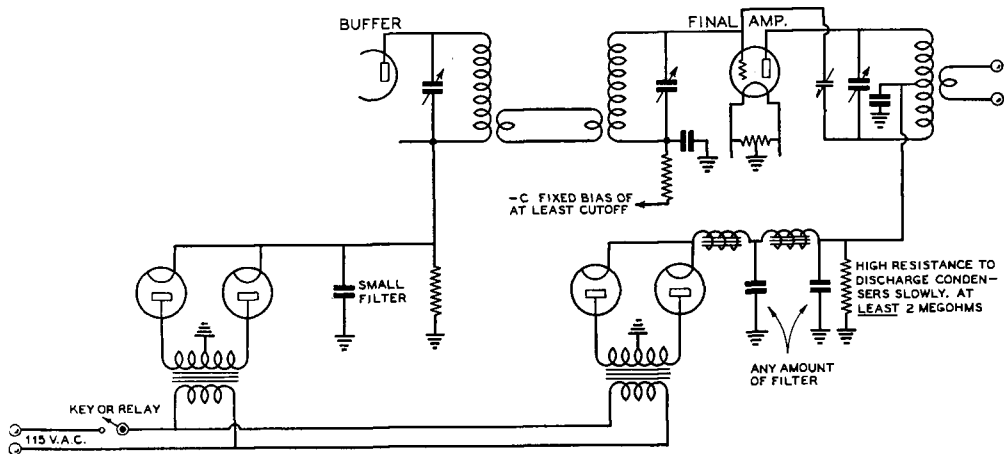

Figure 40.

IMPROVED PRIMARY KEYING WITHOUT CLICKS OR "TAILS."

ing possible, without clicks or tails, and the plate supply to the final amplifier can be very well filtered without introducing tails to the dots.

The final amplifier must have a fixed bias supply equal to more than cut off value, so that when the grid excitation from the buffer stage is removed the amplifier output will drop immediately to zero, in spite of the filter condenser's being fully charged in the final amplifier circuit. The bleeder across the final plate supply filter should have a very high resistance so that the filter condenser will hold its charge between dots and dashes. This will allow a quick application of plate voltage as soon as the grid excitation, supplied by the buffer stage, is applied to the final amplifier.

The buffer plate supply is keyed; its filter circuit consists of a single $2\text{-}\mu\text{fd.}$ filter condenser, shunted by the usual heavy-duty high-current bleeder resistor. This small filter has no appreciable time-lag, and will not add tails to the dots and dashes, but it does provide sufficient time-lag for key click elimination. The small amount of filter will not introduce a.c. hum modulation into the output of the final amplifier, because the latter is operated in class C, under saturated grid conditions. A moderate a.c. ripple in the grid excitation will not introduce hum in the output circuit under this operating condition.

Grid-Controlled Rectifiers. By the incorporation of grid-controlled rectifiers in a high-voltage power supply, one can enjoy keying that has practically all the advantages

of primary keying with none of the disadvantages. The only disadvantage to this type of keying as compared to primary keying is that of the small amount of additional equipment needed and the additional expense of the special rectifiers.

Inasmuch as no power is required to block the grids, there is little sparking at the relay contacts. And because the keying is ahead of the power supply filter, the wave train or keying envelope is rounded enough that clicks and keying impacts are eliminated. In fact, it is important that no more filter be used than is required to give a good T 9 note, inasmuch as excessive filter will introduce lag and put tails on the keying. The optimum ratio and amounts of inductance and capacity in the filter will be determined by the load on the filter (plate voltage divided by plate current). With high plate voltage and low plate current (high impedance load) more inductance and less capacity should be used, and vice versa.

Of the large number of possible circuit combinations, three of the most practical are illustrated. The circuit shown in figure 41 at A is perhaps the simplest and most trouble-free, but has the disadvantage of requiring bias batteries. The relay contacts handle little power, but must be insulated from ground for the high voltage.

At B is shown the simplest method not requiring batteries. If used as shown, the bias transformer must be insulated for the full plate voltage (secondary to both primary and case). Unfortunately, b.c.l. transformers

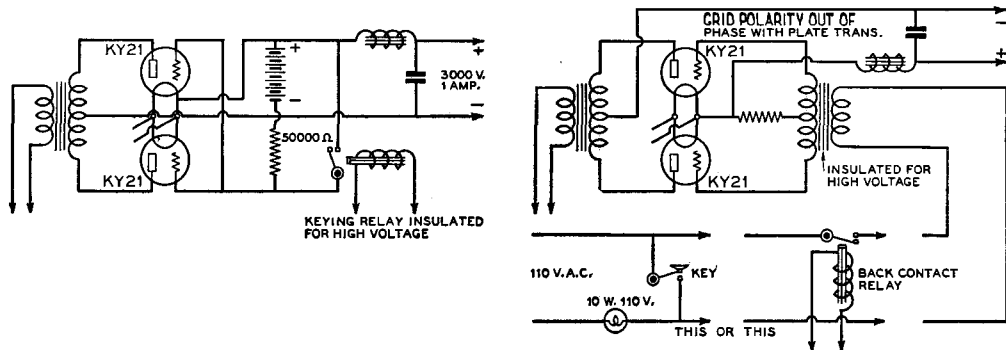

Figure 41.
GRID-CONTROLLED RECTIFIER KEYING SYSTEMS.
 Two methods of using grid-controlled rectifiers for clickless, sparkless keying.

were not designed to withstand 3,000 or 4,000 volts r.m.s., either between windings or to the case. The circuit shown in figure 42 allows the use of a small broadcast-receiver type transformer for bias supply to the rectifiers. In this case the whole transformer is at the power-supply voltage above ground and it must be well insulated from metal chassis and other grounded portions of the circuit.

Blocked Grid Keying. The negative grid bias in a medium- or low-power r.f. amplifier can easily be increased in magnitude sufficiently to reduce the amplifier output to zero. The circuits shown in figures 43 and 44 represent two methods of such blocked grid keying.

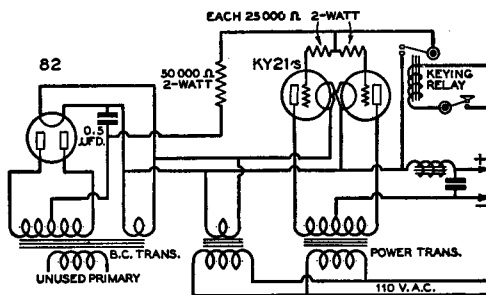

Figure 42.
ALTERNATIVE GRID-CONTROLLED RECTIFIER KEYING ARRANGEMENT.
 An ordinary broadcast-receiver power transformer may be used with this circuit. The whole transformer must be well insulated from grounded parts of the circuit.

In figure 43, R_1 is the usual grid leak. Additional fixed bias is applied through a 100,000-ohm resistor R_2 to block the grid current and reduce the output to zero. As a general rule, a small 300- to 400-volt power supply with the positive side connected to ground can be used for the additional C-bias supply.

The circuit of figure 44 can be applied by connecting the key across a portion of the plate supply bleeder resistance. When the key is open, the high negative bias is applied to the grid of the tube, since the filament center tap is connected to a positive point on the bleeder resistor. Resistor R_2 is the normal bleeder; an additional resistor of from one-fourth to one-half the value of R_2 is connected in the circuit for R_1 . A disadvantage of this circuit is that one side of the key may be placed at a positive potential of several hundred volts above ground, with the at-

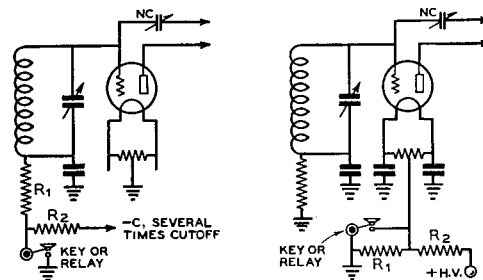

Figure 43.
 Figure 44.
ALTERNATIVE BLOCKED-GRID KEYING CIRCUITS.

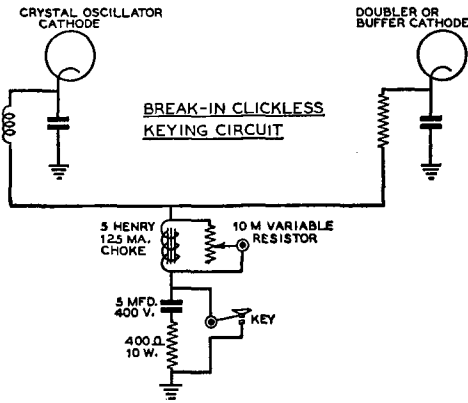

Figure 45.
BREAK-IN KEYING CIRCUIT.

This circuit arrangement may be used for break-in operation where the receiver is in operation on the same band as the transmitter during transmission.

tendant danger of shock to the operator. Blocked grid keying is not particularly effective for eliminating key clicks.

Oscillator Keying. A stable and quick-acting crystal oscillator may be keyed in the plate, cathode or screen-grid circuit for the purpose of minimizing key clicks and for break-in operation. This type of keying requires either fixed or cathode bias on all following r.f. stages, since the r.f. excitation is removed from all of the grid circuits. The key clicks are minimized by the presence of several tuned circuits between the antenna

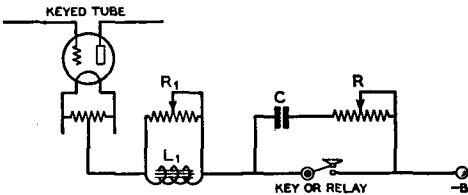

Figure 46.
CLICK FILTER CIRCUIT.

This circuit shows simple center-tap keying with an adjustable click filter to reduce interference caused by this keying method. The amount of inductance and capacity used in the filter depends upon the amount of current being keyed. Ordinarily, L_1 will be between 1 and 5 henrys, R_1 20,000 ohms, C between 0.25 and 2 μ fd., and R about 2000 ohms.

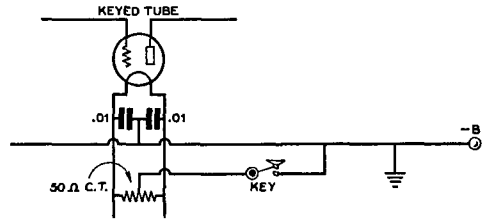

Figure 47.
ORDINARY CENTER-TAP KEYING.

The center tap of the filament transformer must not be grounded, and this transformer must not be used to supply filament voltage to any other stages.

and crystal oscillator in a multistage transmitter. The key clicks act as sideband frequencies and are attenuated somewhat in a multistage transmitter by the resonant tuned circuits which are tuned to the carrier frequency.

If a key click filter is placed in the crystal oscillator circuit, the tone may become chirpy and tails may be added to the ends of the transmitted characters. A practical circuit for clickless keying is illustrated in figure 45, in which both the cathode of the crystal oscillator and the cathode of the next succeeding buffer or doubler circuit are connected through a key click filter.

Two tubes can be keyed very effectively with this type of circuit. The choke coil,

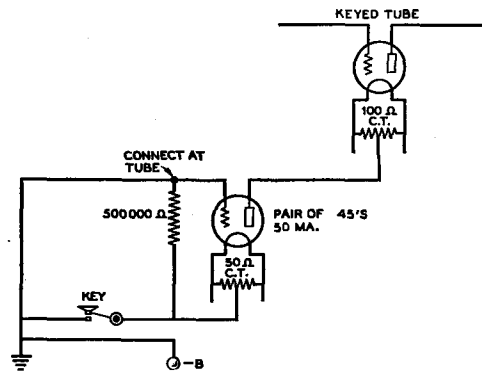
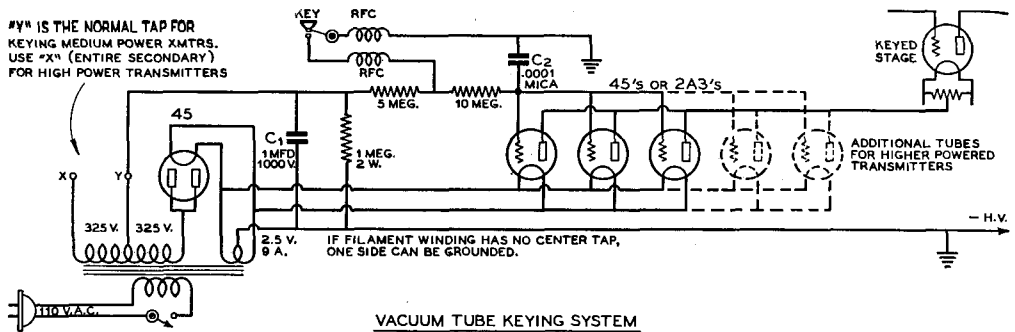

Figure 48.
VACUUM-TUBE KEYING CIRCUIT.

One of the more simple of the vacuum-tube keying circuits. Some current flows through the key in this circuit, and clicks are sometimes produced when the key is opened. Both filament transformers must be insulated from each other and from ground.



VACUUM TUBE KEYING SYSTEM

Figure 49.

VACUUM-TUBE KEYING SYSTEM.

shunted with a semi-variable resistor, provides a series inductance for slowing down the application of cathode current to the two tubes. The inductance of the choke coil can effectively be lowered to one or two henrys by shunting it with a semi-variable resistance so that the time lag will not be excessive. The 0.5- μ fd. condenser and 400-ohm resistor are connected across the key contacts, as close to the key as possible, and these serve to absorb the spark at the telegraph key each time the circuit is opened. This effectively prevents a click at the end of each dot and dash. This same type of key click filter can be connected in the center-tap lead of a final amplifier or buffer-amplifier stage for the elimination of clicks.

Parasitics with Oscillator Keying. When keying in the crystal stage, or for that matter any stage ahead of the final amplifier, the stages following the keyed one must be absolutely stable so that parasitic or output-frequency oscillation will not occur when the excitation is rising on the beginning of each keying impulse. This type of oscillation gives rise to extremely offensive key clicks which cannot be eliminated by any type of click filter; in fact a filter designed to slow up the rate at which signal comes to full strength may only make them worse.

Center-Tap Keying. The lead from the center-tap connection to the filament of an r.f. amplifier tube can be opened and closed for keying a circuit. This opens the B-minus circuit, and at the same time opens the grid-bias return lead. For this reason the grid circuit is blocked at the same time that the plate circuit is opened, so that excessive sparking does not occur at the key contacts. Unfortunately, this method of keying applies the power too suddenly to the tube, produc-

ing a serious key click in the output circuit, which generally is coupled to the antenna. This click often can be eliminated with the key click eliminator shown in figures 45 and 46.

Vacuum Tube Keying. Center-tap keying as shown in figure 47 never should be used, because this circuit produces extremely bad key clicks. The key click filter in figure 46 always can be connected into the center-tap lead as an external unit. A more effective key click filter for the center-tap lead is made possible through the use of vacuum tubes. A simple vacuum tube keying circuit is shown in figure 48.

The keying tube is connected in series with the center-tap lead of the final r.f. amplifier. The grid of the keying tube is short-circuited to the filament when the key is closed, and the keying tube then acts as a low resistance in the center-tap lead. When the key is opened, the grid of the keying tube tends to block itself and the plate-to-filament resistance of the tube increases to a high value, which reduces the output of the r.f. amplifier approximately to zero. A more effective vacuum tube keying system is shown in figure 49.

In this system, the grids of the keying tubes are biased to a high negative potential when the key is open and to zero potential when the key is closed. The fixed bias supply to the keying tubes provides very effective keying operation. The degree of time-lag (key click elimination) can be adjusted to suit the individual operator, by varying both the capacity of the condenser which is shunted from grid to filament, and the values of the two high resistances in series with the grid and power supply leads. R.f. chokes can be connected in series with the key directly at

the key terminals, to prevent the minute spark at the key contacts from causing interference in nearby broadcast receivers. These r.f. chokes are of the conventional b.c. type. There is no danger of shock to the operator when this keying circuit is used.

The small power supply for this keying circuit requires very little filter and can be of the half-wave rectifier type with a '45 tube as the rectifier. The negative voltage from this power supply only needs to be sufficient to provide cutoff bias to the type 45 keying tubes; potentials of from 100 to 300 volts are needed for this purpose. Approximately 50 milliamperes of plate current in the final amplifier should be allowed per type 45 key-

ing tube. If the final amplifier draws 150 milliamperes, for example, three type 45 keying tubes in parallel will be required.

One disadvantage of vacuum tube keying circuits is a plate supply potential loss of approximately 100 volts, which is consumed by the keying tubes. The plate supply therefore should be designed to give an output of 100 volts more than ordinarily is needed for the r.f. amplifier. This loss of plate voltage is encountered because the plate-to-filament resistance of the type 45 tubes, at 50 milliamperes of current and zero grid potential, is approximately 2000 ohms.

Vacuum-tube keying is applicable to high-speed commercial transmitters, as well as for amateur use.

CHAPTER EIGHT

Radiotelephony Theory

Radiotelephony is the transmission by radio of audio waveforms which contain the desired intelligence of the communication. A radiotelephone transmitter differs but little fundamentally from a c.w. telegraph transmitter except for the audio-frequency system which is required to modulate the radiophone transmitter. Both require a frequency determining stage, a series of frequency multipliers and power amplifiers to bring the output up to the desired frequency and amount of power, and a high-voltage direct current power supply for the various stages. This chapter will deal with the theory of various modulation systems and with the theory and design of the audio channel required in the transmitter which is to be used for radiotelephony.

Modulation

Any type of continuous wave transmitter puts out a steady flow of radio-frequency energy which is varied in accordance with the intelligence which it is desired to transmit. This steady flow of r.f. energy is called the carrier or the carrier wave of the transmitter. If the outgoing carrier wave is broken up into short and somewhat longer pulses to conform with the international Morse code, the transmitter is said to be a c.w. radio telegraph transmitter. However, if either the amplitude or the frequency of the outgoing carrier wave is varied in accordance with a voice or music waveform, the source of the signal is said to be a radiotelephone transmitter. Any variation in the output of a transmitter, either c.w. or phone, is called modulation. However, the term is much more generally applied to modulation as applied to a radiophone transmitter.

Frequency Modulation, FM. Although frequency modulation has, until recently, been thought of only as the undesirable result of amplitude modulation of the plate voltage of a self-controlled oscillator, recent develop-

ments by Major E. H. Armstrong have shown that pure frequency modulation of an ultra-high-frequency carrier has many advantages over amplitude modulation from the standpoint of signal-to-noise ratio.

In the Armstrong system of frequency modulation the *frequency* of a u.h.f. transmitter is modulated in accordance with the voice or music to be transmitted. The *amplitude* of the carrier with and without modulation remains constant. A receiver which is receptive only to variations in the frequency of the incoming carrier discriminates to a very large extent against any variations in the amplitude of incoming signals. Since static crashes and man-made interference cause great variations in the amplitude of the carrier and only extremely small amounts of frequency modulation, this system of frequency modulation gives very high quality reception with an almost total absence of noise.

Since frequency modulation has recently become of considerable importance in the field of radio communication, a complete chapter has been devoted to the theory and practice of this new subject. The reader is, therefore, referred to *Chapter Nine*.

Amplitude Modulation, AM. The system of modulation most widely employed at the present time for voice, music, television, facsimile, and c.w. transmission utilizes variation in the *amplitude* of the outgoing carrier in accordance with the intelligence to be transmitted. The most simple way of obtaining amplitude modulation is simply the shutting on and off of the transmitted carrier by means of a telegraph key or analogous device as used in c.w. telegraph transmission. Such keying systems are discussed in the chapter on *Transmitter Theory*. Systems of modulating the amplitude of a carrier in accordance with voice, music, or similar types of complicated waveforms are many and varied and will be discussed later on in this chapter.

Sidebands. When a carrier wave is modulated by an audio frequency tone (varied in amplitude at an audio frequency), a result of the process of modulation is the production of additional frequencies in the output of the transmitter which are equal to the *sum* of the carrier and the modulation frequency and the *difference* between the two frequencies. For example, if the carrier frequency is 14,200 kc. and it is being modulated by a frequency of 2 kc. (2000 cycles) there will be two sidebands formed, one on either side of the carrier frequency. One will be equal to the sum of the two frequencies, 14,202 kc., and the other will be equal to their difference, 14,198 kc. The frequency of the sidebands is independent of the amount of modulation of the carrier; it is determined only by the frequency of the modulating tone. This assumes, of course, that the maximum modulation capability of the transmitter is not being exceeded.

If the signal modulating the carrier consists of a number of different frequencies, as would be the case with voice or music modulation, sidebands will be formed by each of the modulating frequencies. The signal radiated by the transmitter will occupy a *band* of frequencies including the carrier and the highest modulation frequency on either side of the carrier. For example, if the highest modulation frequency is 5000 cycles, the signal emitted by the transmitter will occupy a band from 5000 cycles above to 5000 cycles below the carrier frequency. Thus the total band taken up by a carrier with 5000-cycle modulation will be *twice* the modulation frequency in width, or 10,000 cycles wide. This is true of any type of modulating waveform; the band taken up by the signal from the transmitter will be twice as wide as the highest modulation frequency.

Frequencies up to at least 2,500 cycles are required for good speech intelligibility, and frequencies as high as 5,000 or 6,000 cycles are required for good music fidelity.

When audio frequencies as high as 5,000 cycles are to be transmitted, the radio-frequency channel would have to be 10,000 cycles (10 kilocycles) in width, since both the upper and lower side band frequencies are generated in the modulated r.f. stage.

Since the bands of frequencies available to amateurs for radiophone transmission are limited, and since the band of frequencies taken up by a transmitter which is being modulated by needless high frequencies is quite wide, it would be advisable if all amateurs would limit the maximum frequencies which their speech amplifiers would pass to

about 3000 cycles. The passage of this frequency as maximum will give good intelligibility with a fair amount of crispness to the quality, and still the modulated carrier of the transmitter would occupy a maximum band only 6 kilocycles in width.

Mechanics of Modulation. A c.w. or unmodulated carrier wave is represented in A, figure 1. An audio-frequency wave is represented by curve B. When this audio-frequency wave B is applied to the modulated stage, the resultant wave may be represented as in C and D. The *average amplitude* of the carrier wave remains constant because the decrease in amplitude is the same as the increase (up to 100 per cent). In C, figure 1, the carrier wave is shown to be approximately 50 per cent modulated, and D shows a 100 per cent modulated wave.

In order to obtain 50 per cent modulation in a plate-modulated system, only one-fourth as much audio-frequency power is required as for 100 per cent modulation. However, the audio signal which is received at a distant point after being *demodulated* (de-

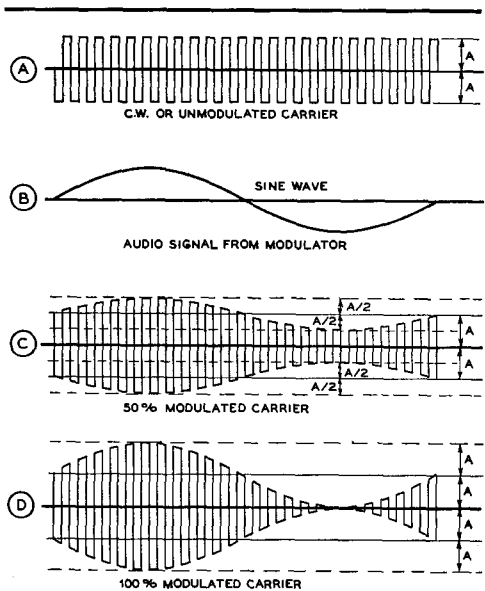

Figure 1.
MODULATION OF A CARRIER WAVE.

The top drawing (A) represents a continuous carrier wave; (B) shows the audio signal output from the modulator. (C) shows the audio signal impressed upon the carrier to the extent of 50 per cent modulation, and (D) shows the carrier with 100 per cent modulation. The carrier wave proper is also a sine wave but has been drawn in this manner to simplify the representation.

ted) is in proportion to the percentage of modulation of the transmitter. If the peaks of modulation are reduced from 100 per cent down to 50 per cent, the result is a decrease in range of the transmitter.

The *average* amplitude of the carrier frequency wave is constant in most systems, but the *instantaneous power output* varies from approximately zero to four times that of the power of the unmodulated carrier wave. In a sinusoidally modulated wave, the antenna current increases approximately 22 per cent for 100 per cent modulation with a pure tone input; the r.f. meter in the antenna circuit indicates this increase in antenna current. The *average power* of the r.f. wave increases 50 per cent for 100 per cent modulation.

This indicates that in a plate-modulated radiotelephone transmitter the audio-frequency channel must supply this additional 50 per cent increase in average power. If the power input to the modulated stage is 100 watts, for example, this *average power* will increase to 150 watts at 100 per cent modulation, and this additional 50 watts of power must be supplied by the *modulator* when plate modulation is used. The actual antenna power is a constant percentage of the total value of input power.

Percentage of Modulation. The amount by which a carrier is being modulated may be expressed either as a modulation factor, varying from zero to 1.0 at maximum modulation, or as a percentage. The percentage of modulation is equal to 100 times the modulation factor. Figure 2A shows a carrier wave modulated by a sine-wave audio tone. A picture such as this might be seen on the screen of a cathode-ray oscilloscope with saw-tooth sweep on the horizontal plates and the modulated carrier impressed on the vertical plates. The same carrier without modulation would appear on the oscilloscope screen as figure 2B.

The percentage of modulation of the positive peaks and the percentage of modulation of the negative peaks can be determined from two oscilloscope pictures such as shown. In

addition, the presence or absence of carrier shift, or a change in the average amplitude of the carrier, can be determined from a picture such as figure 2A alone.

The modulation factor of the positive peaks may be determined by the formula:

$$M = \frac{E_{\max} - E_{\text{car}}}{E_{\text{car}}}$$

The factor for negative peaks may be determined from this formula:

$$M = -\frac{E_{\min} - E_{\text{car}}}{E_{\text{car}}}$$

In the two above formulas E_{\max} is the maximum carrier amplitude with modulation and E_{\min} is the minimum amplitude; E_{car} is the steady-state amplitude of the carrier without modulation. Since the deflection of the spot on a cathode-ray tube is linear with respect to voltage, the relative voltages of these various amplitudes may be determined by measuring the deflections, as viewed on the screen, with a rule calibrated in inches or centimeters. The percentage of modulation of the carrier may be had by multiplying the modulation factor thus obtained by 100.

Carrier shift, or a change in the *average* amplitude of the carrier with modulation, may be determined from a figure such as 2A through the use of the following formula:

$$\frac{E_{\max} + E_{\min}}{2} = E_{\text{car}}$$

This formula is a statement of the condition that should exist in a properly modulated carrier. If the result obtained from the left hand side of the equation is less than E_{car} , carrier shift is in a negative direction. If the result is more than E_{car} , carrier shift is in a positive direction. The latter usually occurs when the carrier is modulated in excess of 100 per cent.

Modulation Capability. The modulation capability of a transmitter is the maximum percentage to which that transmitter may be modulated before spurious sidebands are generated in the output or before the distortion of the modulating waveform becomes objectionable. The highest modulation capability which any transmitter may have is 100 per cent modulation on the negative peaks. The maximum permissible modulation of many transmitters is less than 100 per cent. The modulation capability of a transmitter may be limited by insufficient excitation or

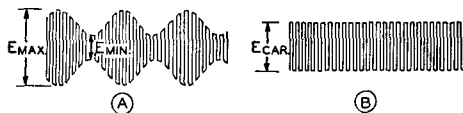

Figure 2.
MODULATED CARRIER DIAGRAM TO REPRESENT MODULATION PERCENTAGE.

grid bias to a plate modulated stage, too light loading of any type of amplifier carrying modulated r.f., insufficient power output capability in the modulator, or too much excitation to a grid-modulated stage or a class-B linear amplifier. In any case the FCC regulations specify that no transmitter be modulated in excess of its modulation capability. Hence, it is desirable to make the modulation capability of a transmitter as near as possible to 100 per cent so that the carrier power may be used most efficiently.

Extended Positive Peak Modulation. The manner in which the human voice is produced by the vocal cords gives rise to a certain dissymmetry in the waveform of voice sounds when they are picked up by a good-quality microphone. This is especially pronounced in the male voice, and more so on certain voiced sounds than on others. The result of this dissymmetry in the waveform is that the voltage peaks on one side of the average value of the wave will be considerably greater, often two or three times as great, as the voltage excursions on the other side of the zero axis. The average value of energy on both sides of the wave is, of course, the same.

The net result of this dissymmetry in the male voice waveform is that especial care must be taken when modulating a transmitter if maximum sideband energy is to be obtained without distortion due to negative peak clipping or to exceeding the maximum upward modulation capability of the transmitter. The simplest solution to the problem is to pole the phase of the exciting waveform so that the large excursions in voltage are in the direction of positive modulation. This will allow a considerably higher average modulation percentage to be obtained before negative peak clipping, with its attendant serious splatter, is obtained—provided the class C amplifier is capable of *positive* modulation percentages in excess of 100 per cent. From this condition the name Extended Positive Peak Voice modulation is taken.

The most satisfactory way of determining the proper phase for the modulating waveform is to look at the modulated waveform on a cathode-ray oscilloscope, and then to reverse the polarity of the audio somewhere in the speech system while a prolonged speech sound such as “. . . errrrr” is being voiced. The polarity may be changed by reversing the microphone leads, the leads of any low-impedance line between the speech amplifier and the transmitter, or by reversing the leads to any transformer in the audio system. In either one polarity or the other the “fingers”

of modulating voltage will be seen to extend in the proper upward direction.

Systems of Amplitude Modulation

There are many different systems and methods for amplitude modulating a carrier but they may all be grouped under two general classifications: *variable efficiency* systems, in which the average input to the stage remains constant with and without modulation and the variations in the efficiency of the stage in accordance with the modulating voltage accomplish the modulation; and *constant efficiency* systems in which the input to the stage is varied by one means or another to accomplish the modulation. The various systems under each classification have individual characteristics which make certain ones best suited to particular applications.

Variable Efficiency Modulation. Since the average input remains constant in a stage employing variable efficiency modulation, and since the average power output of the stage increases with modulation, the limiting factor in such an amplifier is the plate dissipation of the tubes in the stage when they are in the unmodulated condition. Hence, for the best relation between tube cost and power output, the tubes employed should have as high a plate dissipation rating per dollar as possible.

The plate efficiency in such an amplifier is doubled when going from the unmodulated condition to the peak of the modulation cycle. Hence, the unmodulated efficiency of such an amplifier must always be less than 45 per cent, since the maximum peak efficiency obtainable in a conventional amplifier is in the vicinity of 90 per cent. Since the peak efficiency in certain types of amplifiers will be as low as 60 per cent, the unmodulated efficiency in such amplifiers will be in the vicinity of 30 per cent.

The various common systems of efficiency modulation are: grid-leak modulation, class BC grid modulation, class C grid modulation, screen-grid modulation, suppressor-grid modulation, and (a special case) cathode modulation. The class B linear amplifier also falls in this classification. Each of these various systems will be described individually.

Grid Leak Modulation. The several popular forms of grid modulation operate on the same general principle, but under somewhat different conditions. In all systems, the audio-frequency power is impressed upon the grid circuit, and the r.f. amplifier operates in a modified class C arrangement.

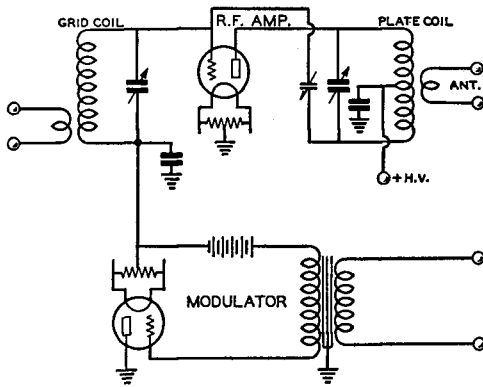

Figure 3.
SIMPLE GRID-LEAK MODULATION.
A modulation system in which the modulator tube acts as a variable grid-leak in series with the grid return of the modulated stage.

The simplest system employs a vacuum tube as a variable grid leak in a class C r.f. amplifier with a very small order of excitation. The modulator tube is driven by the speech amplifier, and its plate impedance varies in accordance with the speech input. The modulator tube receives its plate current from the rectified grid current of the r.f. amplifier. The grid bias of the modulator is adjusted to the point which gives best voice quality, and the r.f. excitation must be similarly adjusted for the same purpose. This system, shown in figure 3, does not give distortionless modulation and is critical in adjustment. The arrangement, however, has been employed quite commonly in low-powered transmitters abroad, and is quite suitable for use in low-powered portable transmitters where it is not desired to carry heavy and bulky modulation equipment.

Class BC Grid Modulation. Figure 4 illustrates the class BC system of grid modulation. This is a system of grid modulation which can be adjusted to give exceptionally good voice quality due to the degeneration in the cathode circuit of the modulated stage.

The r.f. amplifier is operated with fixed bias equal to cutoff. This bias is supplied either from batteries or from a bias pack. Additional bias is obtained from a cathode resistor R_2 in the modulated stage. This resistor should be by-passed for r.f., but not for audio frequencies, by means of filament by-pass condensers no higher in value than $.005 \mu\text{fd.}$

When an audio voltage is applied from the modulator, it is amplified in the r.f. tube,

and degenerative feedback occurs across resistor R_2 . For this reason, the audio power requirements are somewhat greater than for other grid-modulated systems. This degenerative effect, however, produces a very linear modulation characteristic. The d.c. plate current which flows through R_2 should provide an additional bias equal to at least half the theoretical cutoff bias. A higher value of R_2 will result in higher plate efficiency, but at a sacrifice in power output, which can be brought up by using higher plate voltage.

The r.f. grid excitation is adjusted to the point where grid current just starts to flow. Excess r.f. grid excitation can be absorbed by resistor R_1 (figure 4) connected across the grid circuit; this resistor also stabilizes the operation of the circuit and improves the audio quality.

Grid excitation can be conveniently controlled by means of a link-coupling adjust-

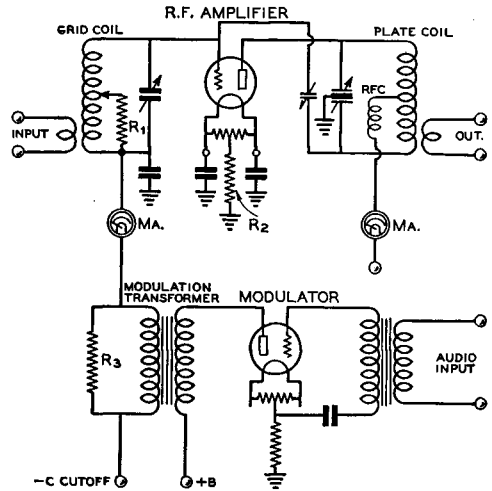

Figure 4.
CLASS BC GRID MODULATION.

A grid modulation system using an unby-passed cathode resistor in series with the return of the modulated stage to give higher plate circuit efficiency with reduced distortion due to the degenerative effect of the resistor, but requiring greater r.f. and audio drive to the stage.

ment. The antenna loading is greater than that required for plate modulation or c.w. operation. This coupling should be increased to a point somewhat beyond that at which maximum antenna or r.f. feeder current oc-

curs for given excitation. The plate efficiency will be between 35 per cent and 40 per cent in a well-designed class BC amplifier.

The circuit constants can be calculated from the group of formulas given here:

- (1) E_b = d.c. plate supply voltage, in volts.
- (2) $W_{\text{plate loss}}$ = rated plate dissipation of the tube in watts.
- (3) μ = amplification factor of the tube.
- (4) W_{input} = d.c. plate input power, in watts.
- (5) W_{output} = r.f. unmodulated carrier output in watts.
- (6) I_p = d.c. plate current, amperes.
- (7) E_{cso} = d.c. battery bias equal to theoretical cutoff bias (one-half total bias).
- (8) R_k = cathode bias resistance, in ohms.
- (9) $W_{\text{input}} = 1.66 W_{\text{plate loss}}$
- (10) $W_{\text{output}} = .66 W_{\text{plate loss}}$

$$(11) I_p = \frac{1.66 W_{\text{plate loss}}}{\mu E_b} (1 + \mu)$$

$$(12) E_{\text{cso}} = \frac{E_b}{1 + \mu}$$

$$(13) R_k = \frac{E_b^2 \mu}{1.66 W_{\text{plate loss}} (1 + \mu)^2}$$

The class BC amplifier shown for grid modulation can be operated as a linear r.f. amplifier at 40 per cent plate efficiency, which is somewhat better than the efficiency obtainable from a conventional linear amplifier (30 to 33 per cent). Slightly better efficiency with less audio driving power and fewer components may be obtained with class C grid modulation. However, if the quality of the latter system is to be improved to compare with class BC grid modulation a separate degenerative feedback circuit external to the amplifier should be employed.

Class C Grid Modulation. The most popular and probably the most satisfactory system of grid modulation is that which is commonly called class C grid bias modulation. Figure 5 illustrates the simple circuit employed; the amplifier can, of course, be either push-pull as indicated or single ended as shown for the other types of grid-modulated amplifiers. The most important difference between this system and the class BC arrangement is in the amount of grid bias employed. The bias on the class BC amplifier usually runs in the vicinity of 1½ to 2½ times cutoff; with the class C grid bias modulation system the bias may run as high as 8 times cutoff under the carrier conditions.

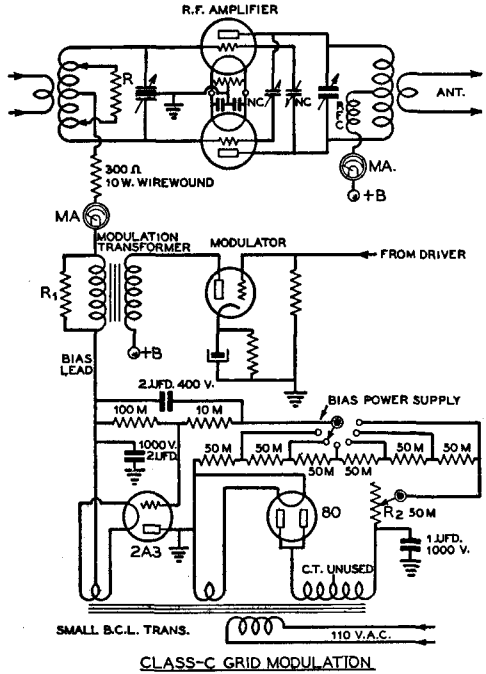

Figure 5.

Class C grid modulation requires high plate voltage on the modulated stage if maximum output is desired. The plate voltage is normally run about 50 per cent higher than for maximum output with plate modulation.

The driving power required for operation of a grid-modulated amplifier under these conditions is somewhat more than is required for operation at lower bias and plate voltage, but the increased power output and improved fidelity obtainable overbalances the additional excitation requirement. Actually, almost half as much excitation is required as would be needed if the same stage were to be operated as a class R plate-modulated amplifier. The resistor R across the grid tank of the stage is to serve as "swamping" to stabilize the regulation of the r.f. driving voltage. From 10 to 50 per cent of the output of the driving stage should be dissipated in this swamping resistor. If a reasonable amount of reserve excitation power is available and if a comparatively high-C grid tank is used on the grid-modulated stage, no swamping resistor will be required when the bias is at least 4 times cutoff.

A comparatively small amount of audio power will be required to modulate the am-

plifier stage 100 per cent. An audio amplifier having 10 watts output will be sufficient to modulate an amplifier with one kilowatt input. Proportionately smaller amounts of audio will be required for lower powered stages. However, the audio amplifier that is being used as the grid modulator should, in any case, either employ low plate resistance tubes such as 2A3's, or else employ degenerative feedback from the output stage to one of the preceding stages of the speech amplifier. This provision of low-plate-resistance output tubes in the grid modulator is to insure good regulation in the audio driver for the grid modulated stage. Good regulation of both the audio and the r.f. drivers of a grid modulated stage is quite important if distortion-free modulation approaching 100 per cent is desired.

With the normal amount of comparatively tight antenna coupling to the modulated stage, a non-modulated carrier efficiency of 40 to 45 per cent can be obtained with substantially distortion-free modulation up to practically 100 per cent. If the antenna coupling is decreased slightly from the condition just described and the excitation is increased to the point where the amplifier draws the same input, carrier efficiencies of 50 per cent are obtainable with tolerable distortion at 95 per cent modulation.

Tuning the Grid-Bias Modulated Stage.

It will be noticed, by reference to figure 5, that a special type of bias supply for the grid-modulated stage has been incorporated as a part of the schematic of the stage. This was done purposely to make it more clear that a special type of high-voltage bias supply is required for best operation of such an amplifier. The arrangement shown has the advantage that the supply has very good regulation up to about 75 ma. of grid current (the maximum capability of a single 2A3) and that the voltage may be varied from nearly zero to about 700 volts; also, this particular supply may be constructed quite inexpensively.

The most satisfactory procedure for tuning a stage for grid-bias modulation of the class C type is as follows. The amplifier should first be neutralized and any possible tendency toward parasitics under any condition of operation should be eliminated. Then a reasonable amount of antenna coupling should be made to the plate circuit, the grid bias should be run up to the maximum available value, and the plate voltage and excitation should be applied. The grid bias voltage should then be reduced until the amplifier draws the approximate amount of plate cur-

rent it is desired to run and modulation is then applied. If the plate current kicks up when a constant tone is applied, the grid bias should be reduced; if the plate meter kicks down, increase the grid bias.

When the amount of bias voltage has been found (by adjusting the fine control, R_2 , on the bias supply) where the plate meter remains constant with modulation, it is more than probable that the stage will be drawing either too much or too little input. The antenna coupling should then be either increased or decreased (depending on whether the input was too little or too much, respectively) until the input is more nearly the correct value. The bias should then be re-adjusted until the plate meter remains constant with modulation as before. By slight jockeying back and forth of antenna coupling and grid bias a point can be reached where the tubes are running at rated plate dissipation and where the plate milliammeter on the modulated stage remains substantially constant with modulation.

The linearity of the stage should then be checked by any of the conventional methods; the trapezoidal pattern method employing a cathode-ray oscilloscope is probably the most satisfactory. The check with the trapezoidal pattern will allow the determination of the proper amount of gain to employ on the speech amplifier. Incidentally, too much audio power on the grid of the modulated stage should not be used in the tuning-up process as the plate meter will kick quite erratically and it will be impossible to make a satisfactory adjustment.

Coupling Transformers for Grid Modulation. The transformer for coupling a single-ended modulator tube such as a 45 or a 2A3 into the grid circuit of the r.f. tube should preferably have a ratio of 1-to-1 or $1\frac{1}{2}$ -to-1 step-down. Class AB output transformers designed for operation from 2A3's or 42 triodes into a 5000-ohm load are suitable for push-pull modulators. The shunt resistance R_1 across the secondary of the modulation transformer should be of some value between 7500 and 10,000 ohms and should be rated at about 3 watts for the single-ended modulator and 10 watts for the push-pull class AB modulator.

Tubes for Grid Modulation. Medium- μ and high- μ triodes are most satisfactory as grid-bias modulated amplifiers. Low- μ tubes can be employed but the amount of grid bias voltage that is required by them for high efficiency class C grid modulation is almost prohibitive unless the plate voltage is comparatively low.

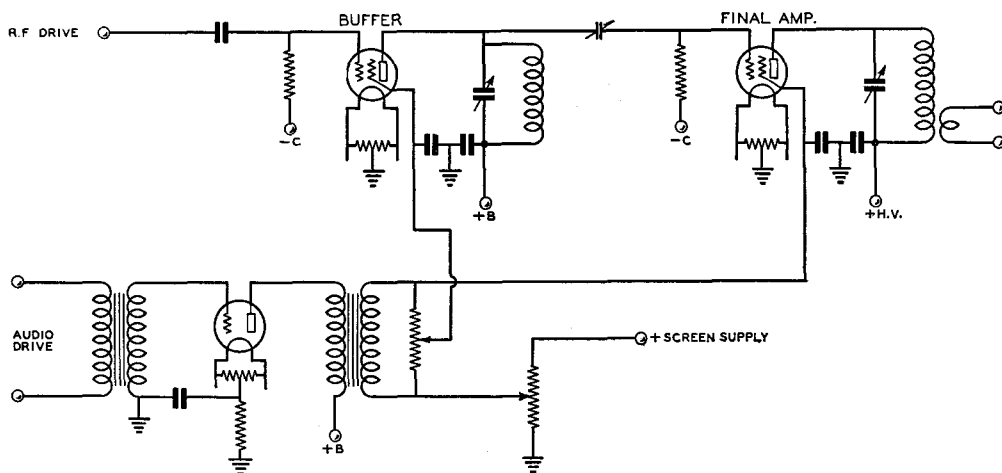

Figure 6.
CASCADE SCREEN-GRID MODULATION.

A screen modulation system in which two successive stages are modulated to give improved linearity with reduced distortion.

Screen-grid tubes and beam tetrodes can be grid-bias modulated quite satisfactorily. The efficiency will be somewhat lower than can be obtained with triodes, but less plate voltage and considerably less excitation power is required. A very satisfactory medium-power control grid modulated phone of great compactness can be built using one of the new, high-power-gain beam tubes.

Screen-Grid Modulation. Modulation can be accomplished by varying the screen-grid voltage at an audio-frequency rate in an r.f. screen-grid tube. The screen-grid voltage must be reduced to between one-half and one-fourth the value of that used for c.w. operation. The r.f. output is correspondingly reduced and the tube then operates as an efficiency-modulated device, somewhat similar to ordinary grid modulation.

The degree of modulation is limited to approximately 90 per cent when the screen-grid of a single stage is modulated. When two cascade stages are modulated, a level of 100 per cent can be reached, with good quality. The r.f. excitation and screen-grid voltages must be carefully adjusted in order to secure satisfactory results. The r.f. excitation to the grid of the final amplifier must be so low that this tube will act somewhat like a class B linear stage. It is possible to use dissimilar tubes in the cascade-modulated circuit shown in figure 6.

The buffer amplifier can be a type 6L6 or 807; the final amplifier one or two 814's or 813's. In any event, both stages should have

the audio modulation voltage applied to the screens. This system of modulation is seldom used because of its complications and because only a few types of tubes are suitable for this application.

Suppressor Modulation. Still another form of efficiency modulation can be obtained by applying audio voltage to the suppressor-grid of a pentode tube which is operated class C. A change in bias voltage on the suppressor-grid will change the r.f. output of a pentode tube, and the application of audio voltage then provides a very simple method of obtaining modulation.

The suppressor-grid is biased negatively to a point which reduces the plate efficiency to somewhat less than 40 per cent. The peak efficiency at the time of complete modulation must reach twice this value. It is difficult to obtain 100 per cent modulation, though 90 per cent to 95 per cent can easily be obtained and with good linearity.

The same modulator design problems apply to the suppressor modulated transmitter as do to a grid-modulated amplifier. The control grid in the suppressor-modulator stage is driven to about the same degree as for c.w. or plate modulation. The r.f. excitation adjustment is not critical, but the excitation should be ample to allow distortionless modulation in this stage.

The quartz crystal should not be placed directly in the grid circuit of any suppressor-modulated stage because of a tendency for frequency modulation and because of poor

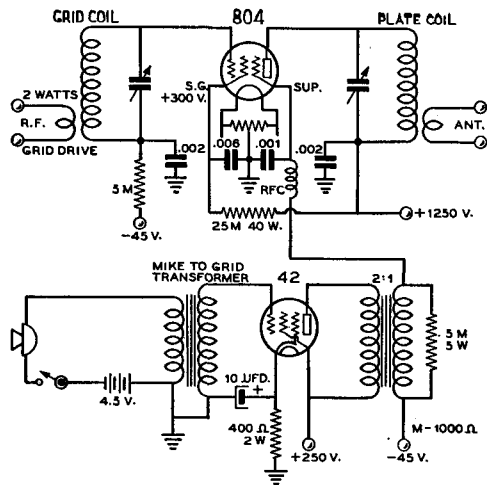

Figure 7.
LOW-POWER SUPPRESSOR MODULATED
PHONE TRANSMITTER.

quality due to insufficient r.f. grid excitation.

A medium powered suppressor modulated amplifier is shown in figure 7. An 804 is used as the amplifier and will supply about 20 watts of carrier. An 803 may be substituted for the 804 to increase the carrier output to about 50 or 60 watts. Either tube may be excited to full output by a 6L6 operating either as a frequency multiplier or as a crystal oscillator. A type 45 or a 42 will serve as modulator for either tube.

It is possible to operate a suppressor modulated amplifier stage as a doubler. The efficiency suffers somewhat but the voice quality will be found to be satisfactory.

Cathode Modulation

Within the last several years a combination modulation system called *cathode modulation* has come to the fore. In fact, it promises to become one of the most widely used methods of amplitude modulating amateur radiophone transmitters. This is easy to understand because cathode modulation offers a workable compromise between the good efficiency but expensive modulator of high-level plate modulation, and the poor efficiency but inexpensive modulator of grid modulation. Cathode modulation consists essentially of an admixture of the two, and hence can have a portion of the advantages of each with the disadvantages of neither.

The efficiency of the average well-designed plate modulated transmitter is in the vicinity

of 75 to 80 per cent, with a compromise perhaps at 77.5 per cent. On the other hand, the efficiency of a good grid-modulated transmitter may run from 28 to maybe 44 per cent, with the average falling toward the lower limit at about 33 per cent. Now since cathode modulation consists of simultaneous grid and plate modulation, in phase with each other, we can theoretically obtain any efficiency from about 33 to 77.5 per cent from our cathode modulated stage, depending upon the relative percentages of grid and plate modulation.

Since the system is a compromise between the two fundamental modulation arrangements, and the relative values of the two are approximately the same, a value of efficiency approximately half way between the two would seem to be the best compromise. Experience has consistently proven this to be the case. A compromise efficiency of about 56.5 per cent, roughly half way between the two limits, has proven to be optimum. Calculation has shown that this value of efficiency will be obtained from the normal cathode modulated amplifier when the audio frequency modulating power is approximately 20 per cent of the d.c. input to the cathode modulated stage.

The Cathode-Modulation Operating Curves.

Figure 9 shows a set of operating

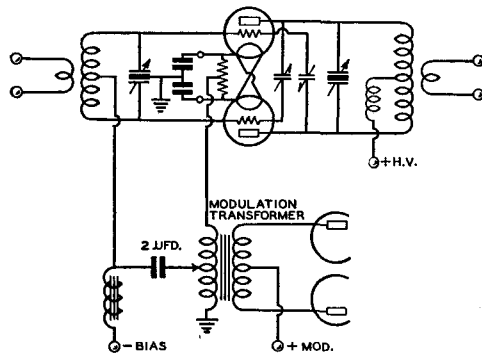

Figure 8.
CONVENTIONAL CATHODE MODULATION.

The modulation transformer in series with the cathode return of the modulated stage must match the cathode impedance of this stage. The choke in series with the grid return of the stage should have from 15 to 40 henrys inductance and should be capable of carrying the full grid current of the stage. The grid tap on the modulation transformer is varied, after the stage has been placed into operation, to give the best modulation pattern as the carrier is viewed on the screen of a cathode-ray oscilloscope.

OPERATION CURVES FOR CATHODE-MODULATED R-F AMPLIFIERS

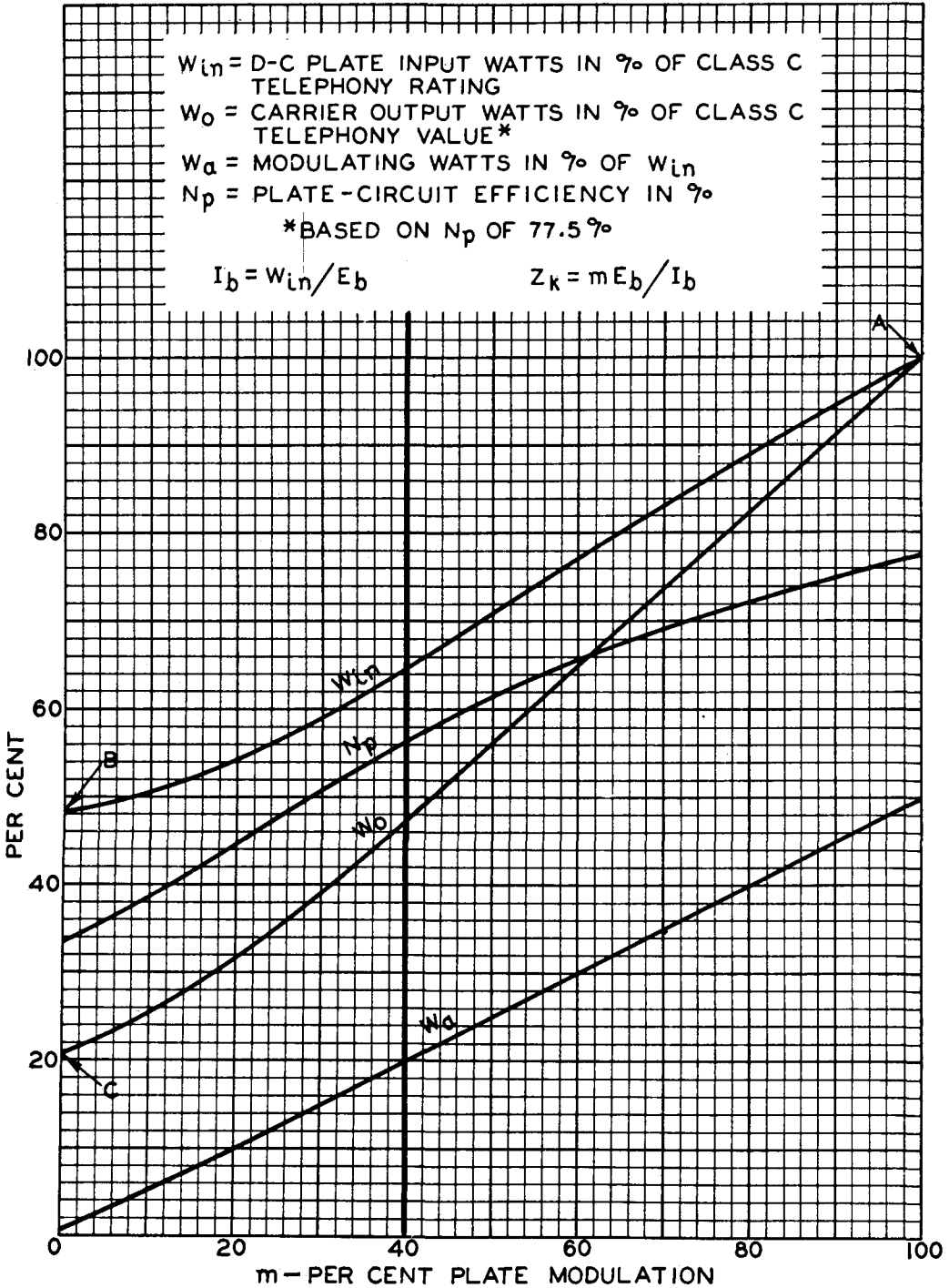

FIGURE 9.

Courtesy RCA Mfg. Co.

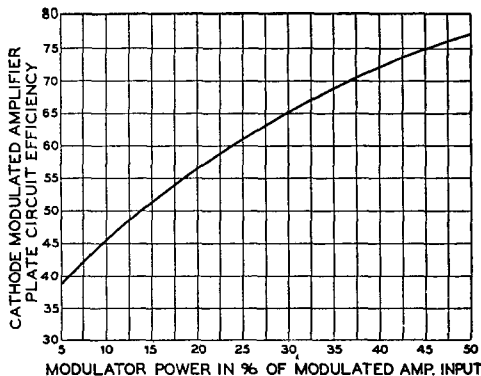

Figure 10.
EFFICIENCY OF A CATHODE MODULATED
AMPLIFIER AS A FUNCTION OF THE POWER
OUTPUT OF THE MODULATOR STAGE.

curves for cathode-modulated r.f. amplifier stages. The chart is a plot of the percentage of plate modulation (m) against plate circuit efficiency, audio power required, plate input wattage in per cent of the plate-modulated class C rating, and output power in percentage of the class C phone output rating. These last two curves are not of as great importance to the amateur designing a new transmitter as are the curves showing the relationship between per cent plate modulation and plate circuit efficiency. Since the relation between per cent plate modulation and the audio power output of the cathode modulator expressed as a percentage of the input to the modulated stage is a linear one, the output power of the modulator (as a percentage of the modulated stage input) is one-half the per cent plate modulation.

Optimum Operating Conditions. As was mentioned before, the optimum operating condition for a normal cathode modulated amplifier is that at which the audio power output of the cathode modulator is about 20 per cent of the d.c. input to the modulated stage. Under these conditions the plate efficiency will be in the vicinity of 56.5 per cent (between 54 and 58 per cent in a practical transmitter), the permissible power input for tubes of late design will be about 65 per cent of the rated class C *modulated* input to the tube. On tubes which do not have ICAS ratings this value of input will be considerably less than the maximum that the tube can handle. The limiting factor in an efficiency modulated amplifier of this type is, to a large extent, plate dissipation. If, under the conditions given above, the plate dissipation of the tube under carrier conditions is

less than the rated value, the plate input can be increased until rated plate dissipation is reached. This, in the case of the older tubes, will allow a considerably greater power output to be obtained. The plate dissipation for any condition of operation can easily be determined by reference to figure 10 and a little calculation. Determine the input from figure 9, and from the efficiency value given in either figure 9 or 10, figure the power output from the stage—subtract this from the plate input and the result is the amount that the tube will be required to dissipate.

Cathode Impedance. The impedance of the cathode circuit of an amplifier which is being cathode modulated is an important consideration in the selection of the transformer which is to be used to couple the modulator to the stage. The cathode impedance of an amplifier is equal to the peak *modulating* voltage divided by the peak a.f. component of the plate current of the stage. The peak *modulating* voltage is equal to the plate voltage times m (the per cent plate modulation, or *twice* the percentage of audio used to modulate the amplifier).

$$\text{Hence: } Z_k = m \frac{E_p}{I_p}$$

Or, simply, the cathode impedance is equal to the per cent plate modulation (expressed as a factor, as 0.4 for 40 per cent plate modulation) times the plate voltage, divided by the plate current.

The Cathode Modulator. The modulator which is used to feed the audio into the cathode circuit of the modulated stage should have a power output of 20 per cent of the d.c. input to the stage for 40 per cent plate modulation. Although this is the recommended percentage of plate modulation, satisfactory operation may be had with other percentage values than this, provided the proper operating values are taken from the chart of figures 9 and 10. The modulator tubes may be operated class A, class AB, or class B, but it is recommended that some form of degenerative feedback be employed around the modulator tubes when they are to be operated in any manner other than class A. This is particularly true of beam tetrodes when used as modulators; if some form of feedback is not used around them the harmonic distortion can easily be serious enough to be objectionable since the cathode modulated stage does not present a strictly linear impedance.

The transformer which couples the modulator to the cathode circuit of the modulated amplifier should match the cathode imped-

ance, as calculated by the formula above, and in addition should have a number of taps so that the proper amount of audio voltage will be impressed upon the grid of the stage. In most cases one of the conventional multi-match output transformers will be satisfactory for the job, the cathode lead and the ground terminal of the stage being connected to the proper taps to give the desired value of impedance. The stage is then coupled to a cathode-ray oscilloscope so that the modulated waveform is shown on the screen. As the stage is being modulated the grid is tapped varying amounts up and down on the modulation transformer until the best waveform is obtained on the screen of the oscilloscope. The more closely the grid is tapped to the cathode, the less will be the amount of audio voltage upon the grid. On the other hand, if the grid return is grounded, the full cathode swing will be placed upon the grid. It will be found that low- μ tubes will require a larger percentage of the total cathode swing upon them than will tubes with higher μ factors. Hence, high- μ tubes will be tapped closer to cathode; low- μ tubes will be tapped more closely to ground.

Excitation. The r.f. driver for a cathode-modulated stage should have about the same power output capabilities as would be required to drive a c.w. amplifier to the same input as it is desired to drive the cathode-modulated stage. However, some form of excitation control should be available since the amount of excitation power has a direct bearing on the linearity of a cathode-modulated amplifier stage. If link coupling is used between the driver and the modulated stage, variation in the amount of link coupling will afford ample excitation variation.

Biasing Systems. Any of the conventional biasing arrangements which are suitable for use on a class C amplifier are also suitable for use with a cathode-modulated stage. Battery bias, grid leak bias, and power supply bias all are usable in their conventional fashion; cathode bias may be used if the bias resistor is by-passed with a high-capacity electrolytic condenser. In any case the bias voltage should be variable or adjustable so that the optimum value for distortionless modulation can be found. If grid leak or cathode bias is used, the value of the grid leak or cathode resistor should be adjustable.

Parallel and Series Cathode Modulation

There are two additional methods of cathode modulation that deserve mention since they offer certain advantages for var-

ious types of circuit applications. Both parallel and series cathode modulation, as they have been called, use a single-ended cathode modulator stage, and neither requires a modulation transformer.

Parallel Cathode Modulation. This circuit is an adaptation of the "cathode follower" type of audio amplifier in which the cathode currents of both the modulator stage and the modulated amplifier flow through a common cathode choke, with the plate of the modulator tube returned to ground. Figure 11 shows two basic parallel cathode modulation circuits and figure 12 shows a particular circuit arrangement for a low-powered transmitter of about 25 watts carrier output. The two main advantages of these circuit arrangements are that: First, since the cathode impedance of the modulator tube is very closely the same as that of the cathode circuit of the tube to be modulated, no matching transformer is needed as a coupling impedance

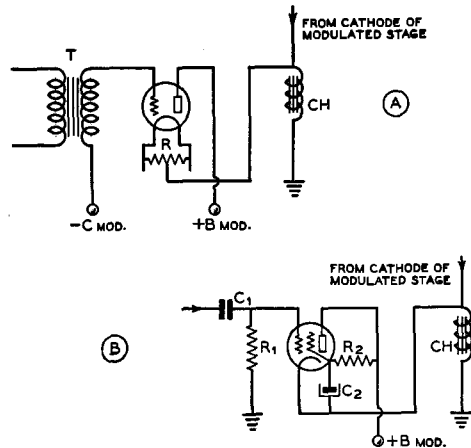

Figure 11.
PARALLEL CATHODE MODULATION
BASIC CIRCUITS.

(A) shows the use of external bias with a triode modulator tube and transformer in its grid circuit. CH can be a choke from 10 to 25 henrys in inductance and capable of carrying the plate current of both the modulator and the modulated stage. T can be a conventional 2-to-1 or 3-to-1 audio transformer fed from the plate of the last audio stage. (B) shows the connection of a beam tetrode tube as modulator with the drop across the choke as its bias. R₁—50,000 ohms, and C₂—8-ufd. 450-volt electrolytic, act to furnish proper screen voltage to the beam tetrode and to keep the screen at cathode potential with respect to audio. Resistance coupling as shown can be used out of the driver stage or an audio transformer as shown in (A) can be used.

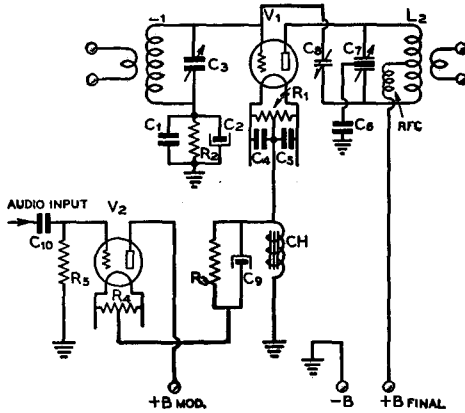

Figure 12.
PARALLEL CATHODE MODULATED R.F. STAGE.

Wiring diagram of a single-ended r.f. amplifier being modulated by a triode parallel cathode modulator. R_3 , by-passed by C_6 , plus the drop across the choke CH furnishes the bias for the modulator tube V_2 .

- | | |
|--|--|
| C_1 —.005- μ fd. mica | R_2 —10,000 to 25,000 ohms, 10 watts |
| C_2 —8- μ fd. 450-volt elect | R_3 —500 ohms, 10 watts fil. trans. |
| C_3 —Conventional for band of operation | R_4 —C.t. res. or tap on fil. trans. |
| C_4, C_5 —.001- μ fd. mica | R_5 —100,000 ohms, 1 watt |
| C_6 —.002- μ fd. 5000-volt mica | L_1, L_2 —Coils for band operated |
| C_7 —Conventional for band of operation | RFC—Conventional for band operated |
| C_8 —Neut. condenser for V_1 | CH—3-to-10 hy. 150-ma. filter choke |
| C_9 —10- μ fd. 100-volt elect. | V_1 —809, T-20, or similar |
| C_{10} —.05- μ fd. 400-volt tubular | V_2 —2A3 or pair 45's in parallel |
| R_1 —C.t. resistor or tap on fil. trans. | |

between them; it is only necessary to insert an ordinary choke capable of carrying the sum of their plate currents in the common cathode circuit of the two tubes. Second, the tubes in the parallel cathode modulator are operating with 100 per cent degenerative feedback; the plate is returned to the h.v. power supply and all the audio voltage output of the stage is impressed upon the grid of the tube 180° out of phase with the incoming voltage.

Degenerative Feedback. It is this inherent degenerative feedback which lowers the effective plate impedance (or cathode impedance, if you want to call it that) to such a great extent. Although the percentage of feedback will be the same in all cases (100 per cent), the value of feedback expressed in decibels will be a function of the effective amplification of the tubes in the modulator.

Due to the fact that there is such a large amount of degenerative feedback around the modulator tube, distortion within this tube will be greatly minimized. Single-ended beam tubes operated in the conventional manner have a rather large percentage of harmonic distortion: 8 to 15 per cent is not uncommon. However, with the audio energy being taken from the cathode of the tube, not only is the plate impedance lowered but the harmonic distortion is lowered by a comparable amount.

Another thing that will be noticed by reference to the paragraph under *Degenerative Feedback* is that the voltage swing required on the grid of the modulator tube is quite high, and that it is determined almost primarily by the power output of the tube rather than by the amplification factor as it would be in a conventional amplifier stage. In any case a peak voltage of 200-500 volts should be figured upon to excite the grid of the parallel-cathode modulator.

Series Cathode Modulation. This is a system of cathode modulation which is ideally suited as an alternative modulating arrangement for a high-power c.w. transmitter. The modulator can be constructed quite compactly and for a minimum cost for components since no power supply is required for it. When it is desired to change over to phone, it is only necessary to plug the series cathode modulator into the cathode return-circuit of the c.w. amplifier stage—the plate supply for the modulator tubes and for the speech amplifier is taken from the cathode voltage drop of the modulated amplifier across the modulator unit.

Figure 13 shows the basic circuit of the system. It is quite similar to the familiar

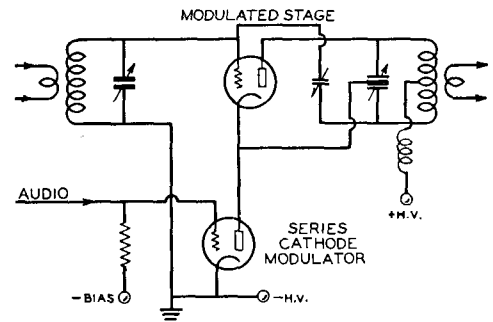

Figure 13.
FUNDAMENTAL SERIES CATHODE MODULATION CIRCUIT.

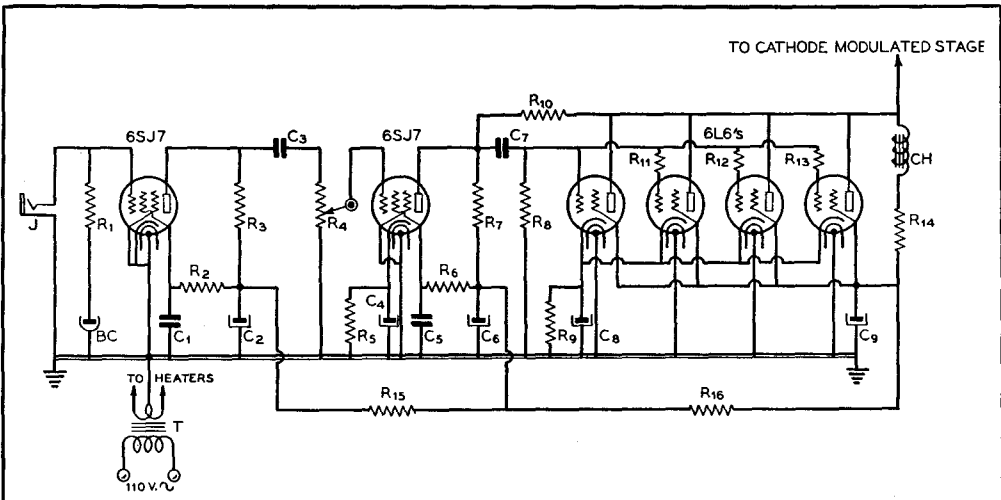

Figure 14.

SERIES CATHODE MODULATOR FOR A HIGH-POWERED R.F. AMPLIFIER.

Wiring diagram of the series cathode modulator using four paralleled 6L6's in the output. The first two stages of speech up to and including R₁₀ and R₈ would remain the same for different output stages.

C ₁ —0.25- μ fd. tubular	C ₇ —.05- μ fd. tubular	R ₇ —500,000-ohm potentiometer	R ₁₁ , R ₁₂ , R ₁₃ —100 ohms, 1 watt
C ₂ —8- μ fd. 450-volt electrolytic	C ₈ —50- μ fd. 50-volt elect.	R ₈ —500 ohms, 1 watt	R ₁₄ —2500 ohms, 10 watts
C ₃ —.02- μ fd. tubular	C ₉ —8- μ fd. 450-volt elect.	R ₉ —500,000 ohms, 1/2 watt	R ₁₅ —10,000 ohms, 1 watt
C ₄ —10- μ fd. tubular	R ₁ —1 megohm, 1/2 watt	R ₁₀ —100,000 ohms, 1 watt	R ₁₆ —10,000 ohms, 1 watt
C ₅ —0.1- μ fd. tubular	R ₂ —500,000 ohms, 1/2 watt	R ₁₁ —100,000 ohms, 1 watt	T—6.3-volt 6-amp. filament trans.
C ₆ —8- μ fd. 450-volt elect.	R ₃ —250,000 ohms, 1/2 watt	R ₁₂ —100,000 ohms, 1/2 watt	CH—10-hy. 65-ma. filter choke
		R ₁₃ —50 ohms, 10 watts	J—Crystal mike jack
		R ₁₄ —500,000 ohms, 1/2 watt	BC—Bias cell

series plate modulation system except that the grid of the modulated stage is returned to ground instead of being returned to the cathode of the modulated stage. The voltage drop across the cathode modulator tube acts as grid bias on the modulated amplifier so that, under ordinary conditions, no additional grid bias will be required on this stage. The number of tubes required in parallel as the series modulator is determined by the total cathode current of the stage being modulated. Figure 14 shows the circuit of a modulator which was used to cathode modulate a pair of 810's with 660 watts of plate input. The tubes in the modulated amplifier ran at about 50 per cent plate efficiency giving an output of about 350 watts. In this arrangement the final stage ran at a plate voltage of 2400 volts, with about 400 volts drop across the cathode modulator, giving a net plate to cathode voltage at the tubes of about 2000 volts. The plate current was 330 ma., the grid current was approximately 40 ma., making the total cathode current of the stage

about 370 ma. The four paralleled 6L6's were able to handle this plate current without difficulty. Similar applications of the system may be made in the case of the majority of c.w. transmitters which normally run from 500 to 1000 watts input. The input will, of course, have to be reduced a substantial amount when the stage is being cathode modulated.

The Class B Linear Amplifier. The operation of the class B linear amplifier has been discussed in the chapter devoted to vacuum-tube theory and hence will only be covered quite generally here. The linear amplifier is not well suited for use in amateur stations since the value of unmodulated plate efficiency is quite low, varying from 30 to 39 per cent.

The grid circuit of a linear amplifier is fed modulated r.f. energy and the stage amplifies carrier and sidebands linearly. The stage is biased to cutoff with no excitation so that when excitation is applied the plate current flows in 180° pulses. This long period of

plate current flow limits the theoretical peak efficiency to 78.5 per cent, the practical peak efficiency to about 65 per cent, and the average carrier efficiency to, as mentioned before, about 30 to 33 per cent for a conventional linear. The efficiency in a class BC linear, due to the greater grid bias and more narrow angle of flow, can be as high as 40 per cent.

The power output from a correctly operating linear amplifier will be about one half the maximum plate dissipation of the stage under the carrier conditions. The schematic of a linear amplifier is exactly the same as a conventional amplifier, whether single ended or push-pull, except that a swamping resistor is usually placed across the grid circuit of the stage. A linear amplifier generally requires from 5 to 10 per cent as much excitation power as will be obtained from its output circuit.

Plate Modulation Systems

Constant efficiency variable-input modulation systems operate by virtue of the addition of external power to the modulated stage to effect the modulation. There are two general classifications that come under this heading, those systems in which the additional power is supplied as audio frequency energy from a modulator, usually called plate modulation systems, and those systems in which the additional power to effect modulation is supplied as direct current from the plate supply.

Under the former classification comes Heising modulation (probably the oldest type of modulation to be applied to a continuous carrier), class B plate modulation, and series modulation. These types of plate modulation are by far the easiest to get into operation and they give a very good ratio of power input to the modulated stage to power output. 65 to 80 per cent efficiency is the general rule. It is for these two important reasons that these modulation systems, particularly class B plate modulation, are at present the most popular among amateurs.

Modulation systems coming under the second classification are of comparatively recent development and have only quite recently been applied even to broadcast work. There are quite a few systems in this class but only two are really worthy of special consideration. These are: the Doherty linear amplifier, and the Terman-Woodyard high-efficiency grid modulator. Both systems operate by virtue of a carrier amplifier and a peak amplifier connected together by means of electrical quarter-wave lines. They will be described later on in this section.

Plate Modulation. Plate modulation is the application of the audio power to the *plate circuit* of an r.f. amplifier. The r.f. amplifier must be operated class C for this type of modulation in order to obtain a radio-frequency output which changes in exact accordance with the variation in plate voltage. *The r.f. amplifier is 100 per cent modulated when the peak a.c. voltage from the modulator is equal to the d.c. voltage applied to the r.f. tube.* The positive peaks of audio voltage increase the instantaneous plate voltage on the r.f. tube to *twice* the d.c. value, and the negative peaks reduce the voltage to zero.

The instantaneous plate *current* to the r.f. stage also varies in accordance with the modulating voltage. The peak alternating current in the output of a modulator must be equal to the d.c. plate current of the class C r.f. stage at the point of 100 per cent modulation. This combination of change in audio voltage and current can be most easily referred to in terms of *audio power in watts.*

The plate efficiency of the plate-modulated stage is constant, and the additional power radiated in the form of sidebands is supplied by the modulator.

One of the advantages of plate (or power) modulation is the ease with which proper adjustments can be made in the transmitter. There is less plate loss in the r.f. amplifier for a given value of carrier power than with other forms of modulation, because the plate efficiency is higher.

By properly matching the plate impedance of the r.f. tube to the output of the modulator, the ratio of voltage and current swing to d.c. voltage and current is automatically obtained. The modulator should have a peak voltage output equal to the average d.c. plate voltage on the modulated stage. The modulator should also have a *peak power* output equal to the d.c. plate input power to the modulated stage. The *average* power output of the modulator will depend upon the type of waveform and upon the type of modulator. If the amplifier is being Heising modulated by a class A stage the modulator must have an average power output capability of one-half the input to the class C stage. If the modulator is a class B audio amplifier, the average power required of it may vary from one-quarter to one-half the class C input depending upon the waveform. However, the *peak* power output of any modulator must be equal to the class C input to be modulated. This subject is completely covered in the section Speech Waveforms.

Heising Modulation. Heising modulation is a system of plate modulation and usually

consists of a class A audio amplifier coupled to the r.f. amplifier by means of a modulation choke coil, as shown in figure 15.

The d.c. plate voltage and plate current in the r.f. amplifier must be adjusted to a value which will cause the plate impedance to match the output of the modulator, since the modulation choke gives a 1-to-1 coupling ratio. A series resistor, by-passed for audio frequencies by means of a condenser, must be connected in series with the plate of the r.f. amplifier in order to obtain modulation up to 100 per cent. The a.c. or audio output voltage of a class A amplifier does not reach a value equal to the d.c. voltage applied to the class A amplifier and, consequently, the d.c. plate voltage impressed across the r.f. tube must be reduced to a value equal to the maximum available a.c. peak voltage.

A higher degree of distortion can be tolerated in low-power emergency phone transmitters which use a pentode modulator tube for securing sufficient audio output, and thus the series resistor and by-pass condenser are usually omitted.

Class B Plate Modulation. High-level class B plate modulation is probably the most satisfactory and least expensive method of plate modulating inputs of from 50 to 1000 watts. Since most amateur phone transmitters fall into this power range, considerable discussion will be given to the various problems associated with the design problems of class B modulators. Figure 16 shows a conventional class B plate-modulated class C amplifier.

The statement that the average modulator power must be one-half the class C input for 100% modulation is correct only if the waveform of the modulating power is a *sine wave*. For amateur purposes, where the modulator waveform is speech, the average modulator power for 100 per cent modulation is considerably less than one-half the class C input. If a modulator is to be used *only with speech*, it seems logical to assume that its design be based upon the peculiarities of speech rather than on the characteristics of the sine wave. The difference between speech and the sine wave is so pronounced that a 100-watt class-B modulator, if *properly designed for speech*, may be used to modulate fully an input of from 300 to 400 watts. The idea cannot be applied to Heising modulators (class A single ended) for reasons that will be apparent when it is recalled that such modulators run hottest when resting, and that the plate dissipation limits the peak output as well as the average output.

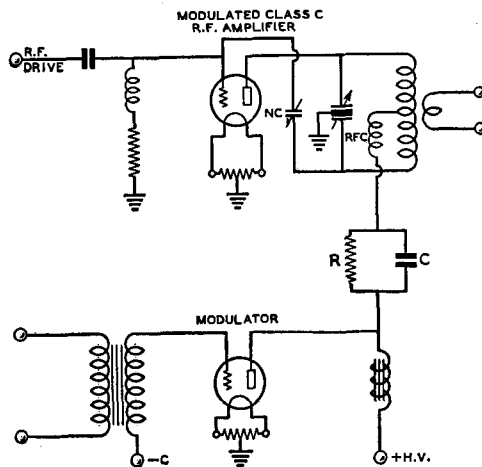

Figure 15.

HEISING PLATE MODULATION.

The resistor R in series with the lead to the class C amplifier drops the plate voltage to a value which will allow a high degree of modulation. The condenser C by-passing it can be 2 to 4 $\mu\text{fd.}$ in capacity and should be able to withstand about the same amount of voltage as is placed upon the modulator for a good safety factor.

Power Relations in Speech Waveforms.

It has been determined experimentally that the ratio of peak to average power in a speech waveform is approximately four to one as contrasted to a ratio of two to one in a sine wave. This is due to the high harmonic content of such a waveform and to the fact that this high harmonic content manifests itself by making the wave unsymmetrical and causing sharp peaks or "fingers" of high energy content to appear. It follows from this that, for speech, the *average* modulator plate current, plate dissipation, and power output are approximately one half the sine-wave values for a given *peak* output power. In other words a 100-watt class-B modulator, if used to modulate 100 per cent with speech an input of 200 watts, delivers an *average* power of only about 50 watts and the average plate current and plate dissipation are only one-half the permissible values. In order to take full advantage of the tube ratings, the design should be altered so that the *peak* power output is increased until the average plate current or plate dissipation becomes the limiting factor.

Both peak power and average power are necessarily associated with waveform. *Peak* power is just what the name implies, the power at the peak of a wave. Peak power,

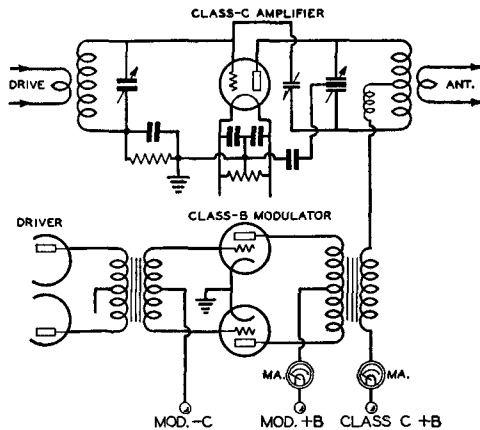

Figure 16.
CLASS B PLATE MODULATION.

although of the utmost importance in modulation, is of no practical significance in a.c. power work, except insofar as the *average* power may be determined from the peak value of a known wave form. There is no time element implied in the definition of peak power; peak power may be instantaneous—and for this reason average power, which is definitely associated with time, is the important factor in plate dissipation. It is possible that the peak power of a given wave form be several times the average value; for a sine wave the peak power is twice the average value, and for speech tones the peak power is approximately four times the *average* value. For 100 per cent modulation the *peak* (instantaneous) audio power must equal the class-C input, although the average power for this value of peak varies widely depending upon the modulator wave form, being 50% for a sine wave and about 25% for speech tones. The problem then of obtaining more speech power consists in obtaining as high a *peak* power as possible without exceeding the *average* plate dissipation or current rating of the tubes.

Since the power output varies as the square of the peak current, the most logical thing to do in order to obtain high peak power is to increase the peak current. This may be done by decreasing the class B modulator plate-to-plate load.

At this point it might be assumed that this increase in peak current is nothing more or less than a gross overload without regard for the manufacturer's ratings. However, a little reflection will show that the manu-

facturer's rating is given as *average* current and that the actual *peak* current (this cannot be read by a meter) varies widely with the mode of operation. An average plate current of 100 ma. in class C operation may call for a dynamic peak plate current of 1 ampere, whereas in class B service this same 100 ma. per tube represents a peak of only 315 ma. No ill effects will result if the peak plate current is increased to such a point that the average plate current with speech as read on the plate meter is equal to the sine-wave value as specified by the manufacturer. With this in mind the *peak* plate current may be safely doubled, assuming that the plate dissipation does not become the limiting factor.

Modulation Transformer Calculations.

The modulation transformer is a device for matching the load impedance of the class C amplifier to the recommended load impedance of the class B or possibly class AB modulator tubes. Modulation transformers are usually designed to carry the class C plate current through their secondary windings as shown in figure 16. The manufacturer's ratings should be consulted to insure that the d.c. plate current being pulled through the *secondary* winding does not exceed the maximum rating.

The load resistance presented by the class C r.f. amplifier to the modulation transformer is calculated by dividing the d.c. plate-to-filament voltage by the plate current of the stage. For example, a pair of 75T tubes in a push-pull amplifier operating at 1200 volts and 250 milliamperes present a load impedance of 1200 divided by 0.25 amperes, or 4800 ohms.

$$Z = \frac{E}{I} = \frac{1200}{0.25} = 4800 \text{ ohms,}$$

where Z is the load impedance of the class C r.f. amplifier.

The power input is 1200 times 0.25 or 300 watts.

By reference to figure 17 we see that a pair of 809's operating at 750 volts will fully modulate an input of 300 watts to a class C amplifier with voice-waveform audio power. In other words, the peak audio output of the class B 809's when operated into a load impedance of 4800 ohms and at a plate voltage of 750 is 300 watts. It just so happens that the recommended plate-to-plate load resistance of the 809's under these operating conditions is the same as the load presented by the class C amplifier. Hence, the modulation transformer should have a primary-to-secondary

Figure 17.
CLASS C INPUT THAT CAN BE FULLY SPEECH-MODULATED BY VARIOUS CLASS B TUBES

Class B Tubes	Class C Power Input	Class B P-P Load	Plate Voltage	Average Speech Plate Current	Class B Bias	Driver Tubes	Average Driving Power	Driver Transformer Ratio	
								Pri. to 1/2	Sec.
TZ-20	250	4850	750	145	0	2-2A3	7	2.6:1	
809	300	4800	750	165	-1½	2-2A3	5	4.5:1	
809	400	7200	1000	150	-8	2-2A3	5	4.5:1	
TZ-40	500	5100	1000	200	-5	2-2A3	8	2.6:1	
TZ-40	600	7400	1250	182	-9	2-2A3	7	2.8:1	
203Z	800	5500	1250	250	0	4-2A3	15	2.75:1	

ratio of 1-to-1. The other operating conditions for the 809 modulator will be found in figure 17. A modulation transformer rated to handle 125 watts of audio will be ample for the purpose.

Suppose we take as another example to illustrate the method of calculation the case of a pair of 54 Gammatrons operating at 200 volts at 250 ma. This amplifier would present a load resistance of 2000 divided by 0.25 amperes or 8000 ohms. The plate power input would be 2000 times 0.25 amperes or 500 watts. By reference to figure 17 we see that a pair of TZ40's at 1000 volts will put out 500 peak audio watts and hence will modulate 500 watts input with speech waveform. The plate-to-plate load for these tubes is given as 5100 ohms; hence, our problem is to match a load of 8000 ohms to the proper load resistance of the TZ40's of 5100 ohms.

A 200-to-300 watt audio transformer will be required for the job. If the taps on the transformer are given in terms of impedances it will only be necessary to connect the secondary for 8000 ohms and the primary to 5100 ohms. If it is necessary to determine the turns ratio of the transformer it can be determined in the following manner. The square root of the impedance ratio is equal to the turns ratio, hence:

$$\sqrt{\frac{8000}{5100}} = \sqrt{1.57} = 1.25$$

The transformer must have a turns ratio of 1.25 to 1, step up. The transformer must be step-up since the higher impedance is on the secondary. When the primary impedance is the higher of the two impedances, the transformer must be connected step-down.

Bass Suppression. Not only can a smaller class B modulator be used for complete modulation of a given carrier power when voice only is to be used, but an increase in the effectiveness of the modulator power can be obtained by incorporation of a simple bass

suppression circuit. Most of the audio power generated in a modulator is represented by the bass frequencies. As the frequencies below 200 or 250 cycles can be greatly attenuated without noticeably affecting the speech intelligibility, it is desirable to do so for communication work. Bass suppression permits a higher percentage modulation at the voice frequencies providing intelligibility, which is equivalent to a substantial increase in power. It is not necessary to suppress the bass frequencies completely; but only to attenuate them until, as the audio gain is increased, overmodulation first occurs at the voice frequencies that afford intelligibility rather than at the power-consuming bass frequencies.

In figures 18 and 19 are shown two simple systems for bass suppression. They are self-explanatory and can be placed between almost any two voltage amplifier tubes in your speech channel. They will work into or out of either triodes or pentodes, but *don't use inverse feedback around the suppressor* or you'll suppress the suppression!

The bass suppressor is an old idea in the talking picture field. It is really surprising how much it cleans up the average boomy ham quality on voice. One reason the new F-type telephone handset mikes sound so good on speech is that they cut off very sharply below 200 cycles.

The bass suppressor shown in figure 18 has a suppression of 6 db at 100 cycles while the arrangement of figure 19 has 0, 4, 6 and 8 db suppression in the four switch positions. The 5-megohm resistors merely eliminate the loud clicks which otherwise would be heard when varying the suppression.

In both of the arrangements, the suppression starts at about 500 cycles although the good work really begins below 200 cycles. The 1000-cycle gain of an amplifier equipped with this type of bass suppression is practically unchanged with the suppressor in or out.

Plate-and-Screen Modulation. When *only* the plate of a screen-grid tube is modulated,

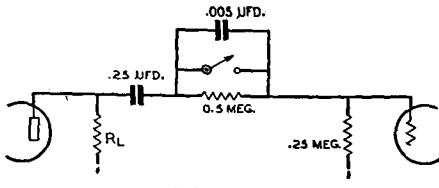

6 DB AT 100 \sim

Figure 18.
Simple dialogue equalizer that can be installed in any speech amplifier.

Figure 19.
Variable bass suppression dialogue equalizer.

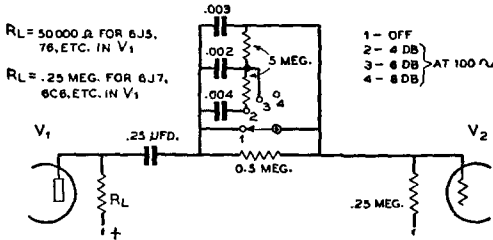

$R_L = 50,000 \Omega$ FOR 6J5, 76, ETC. IN V_1
 $R_L = .25$ MEG. FOR 6J7, 6C6, ETC. IN V_1

1 - OFF
 2 - 4 DB
 3 - 6 DB
 4 - 8 DB) AT 100 \sim

it is impossible to obtain high percentage linear modulation, except in the case of certain beam tubes. A dynatronic action usually takes place when the instantaneous plate voltage falls below the d.c. screen voltage, and this prevents linear modulation. However, if the screen is modulated simultaneously with the plate, the instantaneous screen voltage drops in proportion to the drop in the plate voltage, and linear modulation can then be obtained. A circuit for such a system is shown in figure 20.

The screen r.f. by-pass condenser, C_2 , should not have a value greater than .01 μ fd., preferably not larger than .005 μ fd. It should be large enough to bypass effectively all r.f. voltage without short-circuiting high-frequency audio voltages. The plate by-pass condenser can be of any value from .002 μ fd. to .005 μ fd. The screen-dropping resistor, R_2 , should reduce the applied high voltage to the value specified for operating the particular tube in the circuit. Condenser C_1 is seldom required, yet some tubes may require this condenser in order to keep C_2 from attenuating the high audio frequencies. Different values between .01 and .002 μ fd. should be tried for best results.

Another method is to have a third winding on the modulation transformer, through which the screen-grid is connected to a low-voltage power supply. The ratio of turns between the two output windings depends

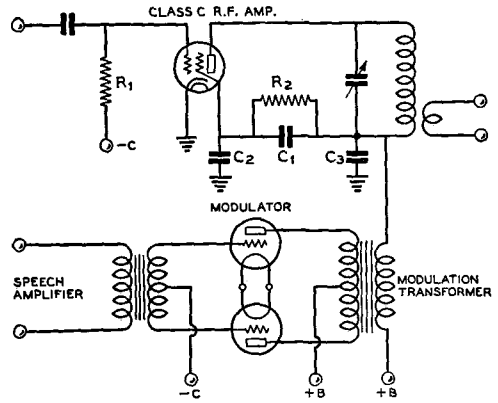

Figure 20.
PLATE AND SCREEN MODULATION OF AN R.F. STAGE.

upon the type of screen-grid tube which is being modulated. The latter arrangement is more economical insofar as modulator power is concerned, because there is no waste of audio power across a screen-grid voltage-dropping resistor. However, this loss is relatively small anyway with most tubes. The special transformer is not justified except perhaps for high power.

Quite good linearity at high percentage modulation can be obtained with some of the *beam*-type transmitting tetrodes by modulating the plate voltage alone.

If the screen voltage for the beam tube is derived from a dropping resistor (not a divider) that is by-passed for r.f. but not a.f., it is possible to secure quite good modulation up to about 90% by applying modulation only to the plate, provided that the screen voltage and excitation are first run up as high as the tube will stand safely. Under these conditions the screen tends to modulate itself to an extent, the screen voltage varying over the audio cycle as a result of the screen impedance increasing with plate voltage, and decreasing with a decrease in plate voltage.

The modulation transformer for plate-and-screen-modulation, when utilizing a dropping resistor, is similar to the type of transformer used for any plate-modulated phone. In figure 20, the combined screen and plate current is divided into the plate voltage in order to obtain the class C amplifier load impedance. The audio power required to obtain 100 per cent sine-wave modulation is one-half the d.c. power input to the screen, screen resistor and plate of the modulated r.f. stage.

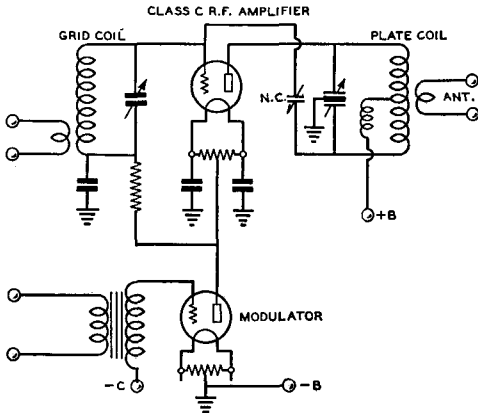

Figure 21.
SERIES PLATE MODULATION.

Series Modulation. Another form of plate modulation is known as *series modulation*, in which the r.f. tube and modulator are in series across the d.c. plate supply, as shown in figure 21.

Series modulation eliminates the modulation choke required in the usual form of Heising modulation. Although this system is capable of very good voice quality, the antenna coupling must be carefully adjusted simultaneously with the C bias in the modulator in order to maintain at least 20 per cent more plate voltage across the modulator than that which is measured from positive B to r.f. tube filament. It is difficult to obtain a high degree of modulation unless a portion of the total plate current is shunted by the r.f. tube through a resistor in series with a high-inductance choke coil. Series modulation is seldom used today except for television work.

The Doherty Linear Amplifier and the Terman-Woodyard Grid-Bias Modulated Amplifier

These two new-design amplifiers will be described collectively since they operate upon a very similar principle. Figure 22 shows a greatly simplified schematic diagram of the operation of both types. Both systems operate by virtue of a carrier tube (V_1 in both figures 22 and 23) which supplies the unmodulated carrier and whose output is reduced to supply negative peaks, and a peak tube (V_2 in figures 22 and 23) whose function is to supply approximately half the positive peak of the modulation cycle and whose

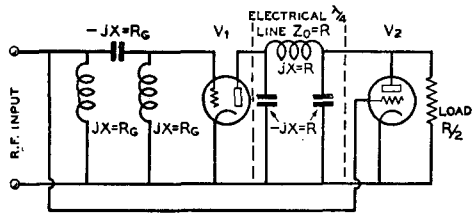

Figure 22.

additional function is to lower the load impedance on the carrier tube so that it will be able to supply the other half of the positive peak of the modulation cycle.

The peak tube is enabled to increase the output of the carrier tube by virtue of an impedance inverting line between the plate circuits of the two tubes. This line is designed to have a characteristic impedance of one half the value of load into which the carrier tube operates under the carrier conditions. Then a load of one half the characteristic impedance of the quarter-wave line is coupled into the output. By experience with quarter-wave lines in antenna-matching circuits we know that such a line will vary the impedance at one end of the line in such a manner that the geometric mean between the two terminal impedances will be equal to the characteristic impedance of the line. Thus if we have a value of load of *one-half* the characteristic impedance of the line at one end, the other end of the line will present a value of *twice* the characteristic impedance of the line to the carrier tube V_1 .

This is the situation that exists under the carrier conditions when the peak tube merely floats across the load end of the line and

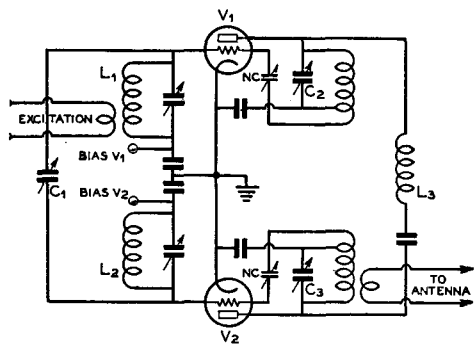

Figure 23.

contributes no power. Then, as a positive peak of modulation comes along the peak tube starts to contribute power to the load until at the peak of the modulation cycle it is contributing enough power so that the impedance at the load end of the line is equal to R , instead of the $R/2$ that is presented under the carrier conditions. This is true because at a positive modulation peak (since it is delivering full power) the peak tube subtracts a negative resistance of $R/2$ from the load end of the line.

Now, since under the peak condition of modulation the load end of the line is terminated in R ohms instead of $R/2$, the impedance at the *carrier-tube* will be *reduced* from $2R$ ohms to R ohms. This again is due to the impedance inverting action of the line. Since the load resistance on the carrier tube has been reduced to half the carrier value, its output at the peak of the modulation cycle will be doubled. Thus we have the necessary condition for a 100 per cent positive modulation peak; the amplifier will deliver four times as much power as it does under the carrier conditions.

On negative modulation peaks the peak tube does not contribute; the output of the carrier tube is reduced until on a 100 per cent negative peak its output is zero.

The Electrical Quarter-Wave Line.

While an electrical quarter-wave line (consisting of a pi network with the inductance and capacity legs having a reactance equal to the characteristic impedance of the line) does have the desired impedance-inverting effect, it also has the undesirable effect of introducing a 90° phase shift across such a line. If the shunt elements are capacitances, the phase shift across the line leads by 90° ; if they are inductances, the phase shift lags by 90° . Since there is an undesirable phase shift of 90° between the plate circuits of the carrier and peak tubes, an equal and opposite phase shift must be introduced in the exciting voltage to the grid circuits of the two tubes so that the resultant output in the plate circuit will be in phase. This additional phase shift has been indicated in figure 22 and a method of obtaining it has been shown in figure 23.

Comparison between Linear and Grid Modulator. The difference between the Doherty linear and the Terman-Woodyard grid modulator is the same as the difference between a linear and a grid-modulated stage. Modulated r.f. is applied to the grid circuit of the Doherty linear with the carrier tube biased to cutoff and the peak tube biased to the point where it draws substantially zero plate current at the carrier condition.

In the Terman-Woodyard grid modulated amplifier the carrier tube runs class C with comparatively high bias and high plate efficiency while the peak tube again is biased so that it draws almost no plate current. Unmodulated r.f. is applied to the grid circuits of the two tubes and the modulating voltage is inserted in series with the fixed bias voltages. From one-half to two-thirds as much *audio* voltage is required at the grid of the peak tube as is required at the grid of the carrier tube.

High Operating Efficiencies. The resting carrier efficiency of the grid-modulated amplifier may run as high as is obtainable in any class C stage, 80 per cent or better. The resting carrier efficiency of the linear will be about as good as is obtainable in any class B amplifier, 60 to 65 per cent. The overall efficiency of the bias-modulated amplifier at 100 per cent modulation will run about 75 per cent; of the linear, about 60 per cent.

The effect of the quarter-wave line in the plate and grid circuits of the amplifier shown in figure 23 is obtained by detuning the circuits enough to give the shunt element of the networks. At resonance, the coils L_1 and L_2 in the grid circuits of the two tubes have each an inductive reactance equal to the capacitive reactance of the condenser C_1 . Thus we have the effect of a pi network consisting of shunt inductances and series capacitance. In the plate circuit we want a phase shift of the same magnitude but in the opposite direction; so our series element is the inductance L_3 whose reactance is equal to the characteristic impedance desired of the network. Then the plate tank condensers of the two tubes C_2 and C_3 are increased an amount past resonance so that they have a capacitive reactance equal to the inductive reactance of the coil L_3 . It is quite important that there be no coupling between the inductors.

Although both these types of amplifiers are highly efficient and require no high-level audio equipment, they are difficult to adjust—particularly so on the higher frequencies—and it would be an extremely difficult problem to design a multi-band rig employing the circuit. However, the grid-bias modulation system has advantages for the high-power transmitter that may make some amateurs interested more than academically in the circuit. For those who are, discussion of the design and adjustment of the circuit has been given in recent issues of the technical radio magazines and in the *Proceedings* of the I.R.E.

Speech Equipment Microphones. The microphone, which changes sound into elec-

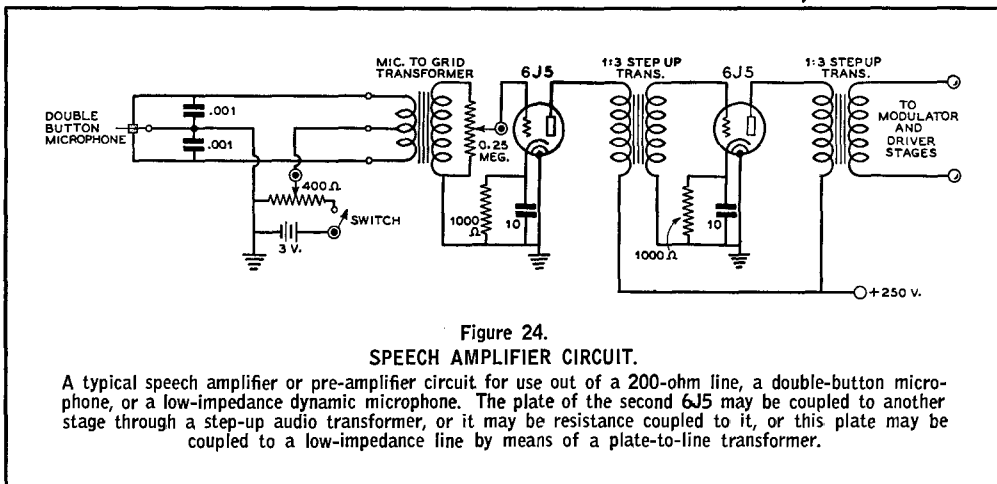

Figure 24.

SPEECH AMPLIFIER CIRCUIT.

A typical speech amplifier or pre-amplifier circuit for use out of a 200-ohm line, a double-button microphone, or a low-impedance dynamic microphone. The plate of the second 6J5 may be coupled to another stage through a step-up audio transformer, or it may be resistance coupled to it, or this plate may be coupled to a low-impedance line by means of a plate-to-line transformer.

trical energy, usually consists of a diaphragm which moves in accordance with the compressions and rarefactions of the air called *sound waves*. The diaphragm then actuates some form of device which changes its electrical properties in accordance with the amount of physical movement.

If the diaphragm is very tightly stretched, the natural period of its vibration can be placed at a frequency which will be out of range of the human voice. This obviously reduces the sensitivity of the microphone, yet it greatly improves the uniformity of response to the wide range encountered for voice or musical tones. If the natural mechanically resonant period of the diaphragm falls within the voice range, the sensitivity is greatly increased near the resonant frequency. This results in distorted output, a familiar example being found in the old-type land-line telephone microphone.

A good microphone must respond equally to all voice frequencies; it must not introduce noise, such as hiss; it must have sufficient sensitivity to eliminate the need of excessive audio amplification; its characteristics should not vary with changes in temperature or humidity, and its characteristics should remain constant over a useful period of life.

The Carbon Microphone. Carbon microphones can be divided into two classes: (1) *Single-button*, (2) *Double-button*. The single-button microphone consists of a diaphragm which exerts a mechanical pressure on a group of carbon granules. These granules are placed behind the diaphragm between two electrodes, one of which is secured directly to the diaphragm and moves in accordance with the vibration of the diaphragm. This vibration changes the pressure on the carbon granules, resulting in a

change of electrical resistance to current flowing between the electrodes, the direct current being supplied from an external source. The variation in resistance causes a change in the current which flows through the primary winding of a coupling transformer, thereby inducing a voltage in the secondary winding of this transformer; this voltage is then amplified by means of vacuum tubes.

Single-button microphones are useful for operation in portable transmitters because their sensitivity is greater than that of other types of microphones, thereby requiring less audio amplification to supply audio modulating power for the transmitter. The objectionable feature of the single-button microphone is its high hiss level. Another is that the diaphragm generally resonates within the voice range, resulting in mediocre tone quality. The better microphones of this type, however, are highly intelligible even though lacking somewhat in fidelity.

Double-Button Microphones. The double-button microphone has two groups of carbon granules arranged in small containers on either side of the diaphragm. This push-pull effect reduces the even-harmonic distortion, resulting in more intelligible modulation. The diaphragm is normally stretched to such an extent that its natural period may be as high as 8,000 cycles per second, which is beyond the range of the human voice. This reduces the sensitivity of the microphone and greater audio amplification is needed to secure the same output as from a single-button carbon microphone. On the other hand, the tone quality from the double-button microphone is better, though the hiss is still present.

The cost of a double-button microphone is a satisfactory index of its performance

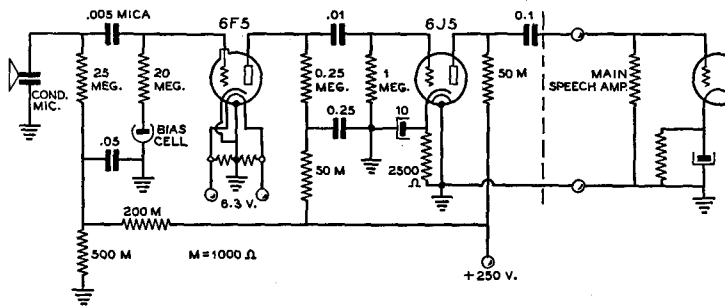

Figure 25.

CONDENSER MICROPHONE PRE-AMPLIFIER.

This pre-amplifier can be used to raise the level of the output of a condenser microphone to a point where it can be fed into the input of a normal speech amplifier. No transformer is needed to couple the 6J5 to the speech amplifier, unless it is desired to use a low-impedance line between them. The pre-amplifier should either be operated from a separate power supply or adequate decoupling should be used between the main speech amplifier and the pre-amplifier.

when purchased from a reliable concern. The output from a *high-quality* two-button microphone is about 45 db below that of a standard single-button microphone.

Condenser Microphones. A condenser microphone has a better frequency response than a carbon microphone and it does not produce a hiss. This type of microphone consists of a highly damped or stretched diaphragm mounted very close to a metal plate, but insulated from the plate. The movement of the diaphragm changes the spacing between the two electrodes, resulting in a change in electrical capacity. When a d.c. polarizing voltage is applied across the plates, an a.c. voltage will be generated when the diaphragm is actuated by reason of the change in capacity between the plates; this voltage can then be amplified by means of vacuum tubes. The diaphragm of a typical condenser microphone is made of duralumin sheet, approximately 1/1000 in. thick, with approximately the same spacing between the diaphragm and the rear heavy plate electrode. The output is approximately 75 db below an ordinary single-button carbon microphone with unstretched diaphragm.

The condenser microphone has a low output level, which necessitates at least two stages of preamplification, the first stage being located very close to the microphone. The output impedance is extremely high and the unit must, therefore, be well shielded in order to prevent r.f. and 60-cycle a.c. hum pickup. It is sensitive to changes in barometric pressure and humidity. More modern types of microphones are replacing the con-

denser type, although the latter are still often used.

Crystal Microphones. The crystal microphone operates on the principle that a change in dimensions of a *piezoelectric* material, such as *Rochelle salt crystals*, generates a small a.c. voltage which can be amplified by means of vacuum tubes. No d.c. polarizing voltage or current or coupling transformer is required for the crystal type of microphone; thus, it becomes a very simple device to connect into an audio amplifier.

Crystal microphones can be divided into two classifications: (1) the diaphragm type, (2) the grille type.

The diaphragm type is relatively inexpensive and consists of a semifloating diaphragm which subjects the crystal to deformation in accordance with the applied sound pressure. The fidelity is equal to that of most two-button carbon microphones and there is no background noise or hiss generated in the microphone itself.

The grille type consists of a group of crystals connected in series or series-parallel for the purpose of obtaining high electrical output without aid of a diaphragm.

The output level varies between -55 db and -80 db for various types of crystal microphones. The grille type is less directional to sound pickup than most other types and is capable of almost perfect fidelity. However, they have the disadvantage of a high thermal-agitation noise level.

Velocity or Ribbon Microphones. The inductive or ribbon-type microphone has a thin, corrugated, metal strip diaphragm

which is loosely supported between the poles of a horseshoe magnet. A minute current is induced in this strip when it moves in a magnetic field, and this current can be fed to the primary of a step-up-ratio transformer of high ratio because of the very low impedance of the ribbon.

The microphone output must be amplified by means of a very high gain preamplifier, because the output level of the older types of ribbon microphones is -100 db and even the newer ones are around -85 db. The inductive type of microphone is rugged and simple in construction. Unfortunately, it cannot be used for close talking without overemphasizing the lower frequencies. It is a velocity, rather than a pressure-operated, microphone and should therefore be placed at least two feet from the source of sound. It is very sensitive to a.c. hum pickup, and this is one of the principal reasons why it is not widely used in amateur practice.

The impedance of the ribbon is so low that it is difficult to design a ribbon-to-grid transformer with good fidelity. Therefore, for best quality, two transformers are usually used in cascade: ribbon-to-200 ohms and 200 ohms-to-grid.

The Dynamic Microphone. The dynamic (moving coil) type of microphone operates on the same principle as the inductive microphone. A small coil of wire, actuated by a diaphragm, is suspended in a magnetic field, and the movement of the coil in this field generates an alternating current. The output impedance is approximately 30 ohms as against approximately one ohm for the ribbon type of microphone. The output level of the high fidelity types is about -85 db, the level varying with different makes. The output level of the p.a. types is somewhat higher and the fidelity is almost as good. This type of microphone is quite rugged, but has the disadvantage of picking up hum when used close to any power transformers.

An inexpensive and very satisfactory dynamic microphone for amateur transmitters can be made from a small, permanent-magnet type, dynamic loudspeaker. One of the newer 5-in. types with alloy magnet will give surprising fidelity at relatively high output level.

A shielded cable and plug are essential to prevent hum pickup. The unit can be mounted in any suitable type of container. The circuit diagram is shown in figure 27.

Directional Effects. Crystal microphones, as well as those of some other types, can be mounted in a spherical housing with the diaphragm oriented horizontally in order to

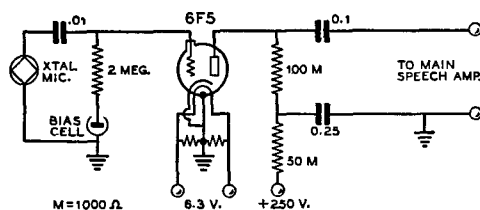
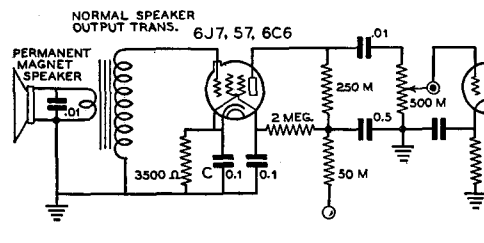

Figure 26.
PRE-AMPLIFIER—GAIN APPROXIMATELY 35 DB.

This pre-amplifier can be used either with a crystal microphone as shown, or with a dynamic microphone by changing the resistance network in the input circuit to a transformer of the correct design to match the dynamic microphone to the grid.

Figure 27.
DYNAMIC MICROPHONE INPUT AMPLIFIER.

A low-cost microphone arrangement using a midget permanent-magnet dynamic speaker as the microphone and its output transformer as the coupling transformer between it and the grid of the first audio stage.



secure a non-directional effect. Decidedly directional effects may be required, on the other hand, and microphones for this purpose are commercially available.

Speech Amplifiers.

That portion of the audio channel between the microphone or its preamplifier and the power amplifier or driver stage can be defined as the *speech amplifier*. It consists of from one to three stages of *voltage amplification* with resistance impedance or transformer coupling between stages. The input level is generally about -50 db in the case of a speech amplifier designed for a double-button carbon microphone or preamplifier input. The input level is approximately -70 db when the speech amplifier is designed for operation from a diaphragm-type crystal microphone. Some conventional speech amplifier circuits are shown in the preceding pages. Other speech

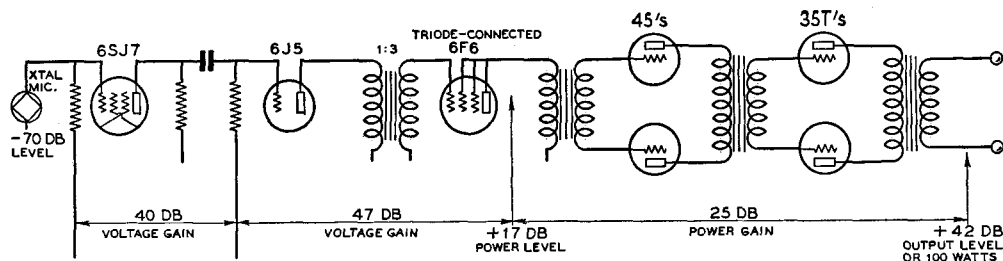

Figure 28.

CALCULATION OF THE GAIN OF THE AUDIO CHANNEL OF A RADIOPHONE TRANSMITTER.

amplifier circuits are shown in the chapter on *Speech and Modulation Equipment*.

It is possible to dispense with the preamplifier with certain types of low-level microphones by designing the speech amplifier input to work at -100 db or so, but it is better practice and entails less constructional care if a speech amplifier with less gain is used, in conjunction with a preamplifier to make up the required overall amplification. Less trouble with hum and feedback will be encountered with the latter method.

Designing a speech amplifier to work at -70 db is comparatively easy, as there is little trouble from power supply hum getting into the input by stray capacitive or inductive coupling.

Amplifier Gain. The power gain in amplifiers or the power loss in attenuators can be conveniently expressed in terms of db units, which are an expression of ratio between two power levels.

A formula for the calculation of db gain or loss is here given:

$$\text{db} = 10 \times \log_{10} \frac{P_2}{P_1}$$

Since power is equal to the product of voltage times current when the power factor is unity, db units can be used to express voltage gain. In this case the formula is:

$$\text{db} = 20 \times \log_{10} \frac{E_1}{E_2}$$

This provides a useful means for computing the overall voltage gain of a preamplifier and the speech amplifier. When adding the gain of several stages, the db units are added or subtracted, which greatly simplifies the calculations.

For example: if a preamplifier has 35 db gain, and the speech amplifier has 65 db gain, the total gain is $35 + 65$, equals 100 db. One hundred db corresponds to a voltage gain of 100,000 times. Thus, for example, if the

microphone level is -100 db the speech amplifier output will be -100 db $+100$ db, or zero db level. Zero level corresponds to a power level of 6 milliwatts.

In order to obtain 60 watts of audio power output, a power gain of 6,000 times will be required, which corresponds to a power gain of approximately 38 db. This amplification can be considered as part of the main power amplifier or modulator, or as part of the speech amplifier, depending upon the particular transmitter under consideration. The important point to remember is that power ratios use the expression: $10 \times \log$, whereas voltage gain between similar impedances is computed by the expression: $20 \times \log$.

Let us take a typical example of radiophone transmitter with a class C amplifier input of 200 watts. For 100 per cent plate modulation, the audio power requirement is 100 watts. This corresponds to a db power level of $+42$ db. Zero db level is 6 milliwatts or .006 watt. (Refer to db power table in chapter 26.)

Therefore, the formula:

$$\text{db} = 10 \times \log_{10} \frac{P_1}{P_2}$$

$$10 \times \log_{10} \frac{100}{.006} = 42$$

The amateur may desire to use a cell (grille) type crystal microphone which is rated at -70 db for average sound levels. This extremely low output must be brought up to a value of 100 watts or $+42$ db. The total gain required will be 112 db.

No preamplifier would be necessary, because this amount of gain can be built into a good speech amplifier and modulator. A typical audio channel which meets these requirements is shown in the skeleton circuit, figure 28.

The first speech amplifier consists of a 6SJ7 connected as a high-gain pentode,

resistance-coupled to a 6J5 speech amplifier which, in turn, is coupled through a step-up transformer into a 6F6 tube which operates as a triode. The latter is connected to a push-pull 45 class AB driver for the final power amplifier or modulator consisting of a pair of 35T's.

The 6SJ7 stage is capable of producing a voltage amplification of 100 times, which corresponds to 40 db.

$$\text{db} = 20 \times \log_{10} \frac{100}{1} = 40$$

The 6J5 and 6F6 triodes with a 3-to-1 step-up interstage transformer will produce a voltage gain of 240.

$$\text{db} = 20 \times \log_{10} \frac{240}{1} = 47$$

Actually, the db voltage gain must be measured between like impedances in order to be correct.

The total speech amplifier gain is 40 + 47, equals 87 db. If the output level of the microphone is -70 db, the output level of the 42 triode will be 87 - 70, equals +17 db. This level corresponds to approximately 300 milliwatts, which is well within the rating of a 6F6 triode driver, and is sufficient to drive the 45 tubes in class AB.

$$17 = 10 \times \log_{10} \frac{P}{.006}$$

Therefore, P equals 0.3 watt or 300 milliwatts.

$$\text{db} = 10 \times \log_{10} \frac{100}{0.3} = 25$$

This can be checked by subtracting 17 from 42, which is 25 db, the power gain between the grids of the 45 tubes and the output of the class B modulator.

With 0.3 watt input to the 45 stage, 9 watts of output can be obtained.

$$\text{db} = 10 \times \log_{10} \frac{9}{0.3} = 15$$

The power gain through the 45 stage is 15 db leaving a power gain of 10 in the 35T class B stage. More power gain could be secured in the 35T stage, thus requiring less gain in the 45 driver stage, and therefore the class B input transformer could have a greater stepdown ratio than in the case of a circuit design in which no leeway in voltage and power gain is provided for.

Modulators. A modulator supplies audio power to the particular r.f. stage in the transmitter which is being modulated. A speech

amplifier does not deliver sufficient power output for modulating a conventional form of r.f. stage delivering more than a very few watts power. The modulator is an audio amplifier which delivers ample power output for completely modulating the d.c. input to the modulated stage. Power requirements of audio amplifiers vary from a fraction of a watt up to 500 watts, for amateur purposes. Low-power transmitters of the grid-modulated or suppressor-grid-modulated types require less than one watt of audio power, whereas a 1-kw. plate-modulated phone transmitter requires 500 watts of audio power for 100% sine-wave modulation.

Classes of Modulators. Class A amplifiers are suitable for low-power grid-modulated, or suppressor-modulated phone transmitters; class AB audio amplifiers for high-power grid-modulated or for low-power plate-modulated phones, and class B audio amplifiers for most economical operation of transmitters in which the audio requirements are greater than about 50 watts. Class AB or class B modulators require a driver stage, which can be considered part of the modulating system proper rather than part of the speech amplifier. The complete modulator essentially consists of a device for converting speech-amplifier output voltage into audio power.

Complete information on receiver and transmitter type tubes for modulator service, as well as for any other portion of a radio-telephone transmitter, will be found in the receiving and transmitting tube chapters *Five* and *Ten*.

Degenerative Feedback.

A system of taking energy from the output of an amplifier or transmitter and feeding it back into the input circuit 180° out of phase with the incoming voltage has come into quite wide usage in recent years. Inverse feedback or degeneration, as it is called, allows greatly improved operation of audio amplifiers and radiophone transmitters to be obtained. It has been found that the proper application of degeneration in an amplifier can be made to reduce greatly the harmonic distortion and otherwise to improve the fidelity. The inclusion of inverse feedback causes a reduction in the gain of an amplifier which can be offset by the addition of a stage of speech amplification. The disadvantage of the additional stage of amplification is far more than compensated for by the reduction in three kinds of distortion commonly known as frequency distortion (change in gain with

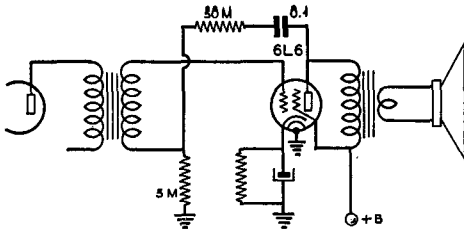

Figure 29.
INVERSE FEEDBACK FOR A SINGLE-STAGE BEAM-TUBE AMPLIFIER.

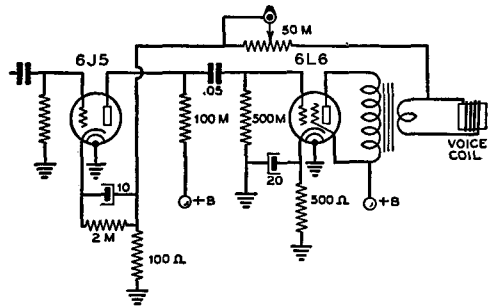

Figure 30.
INVERSE FEEDBACK AROUND A TWO-STAGE AMPLIFIER.

respect to frequency), harmonic distortion, and delay or phase distortion.

The Inverse Feedback Principle. The principle involved in inverse feedback systems is to select a portion of the amplifier output voltage and feed it back into one of the previous circuits, exactly out of phase with the input voltage. In figure 29, a simple method of applying inverse feedback to an audio amplifier is shown. With the values of resistance as indicated, the reverse feedback is approximately 10 per cent. This reduces the gain of the audio amplifier; however, it still has approximately twice the sensitivity of a triode amplifier with similar plate circuit characteristics. The plate circuit impedance of the 6L6 is greatly reduced, an advantage when working into a loudspeaker (because a loudspeaker is not a constant impedance device).

Inverse feedback can be applied in a somewhat different manner, as shown in figure 30, for a two-stage amplifier. This method is particularly desirable, in that feedback pro-

duces better results when the feed-back circuit is connected from the output back to the grid of one of the *preceding* amplifier stages.

The polarity of the secondary winding of the output transformer, in all cases where the feed-back connection is made to the secondary, should be that which will produce degeneration and reduction in amplifier gain, rather than regeneration and howl or increase of gain.

The circuits in figures 31 and 32 indicate methods for applying inverse feedback to three stages of amplification. These two systems are suitable for operation as speech amplifiers and modulators for grid-modulated radio-telephones, or low-power plate-modulated transmitters. The 100-ohm cathode resistor should be located as near as possible to the 6C5 tube cathode terminal in order to prevent undesirable pickup and feedback at frequencies other than those desired.

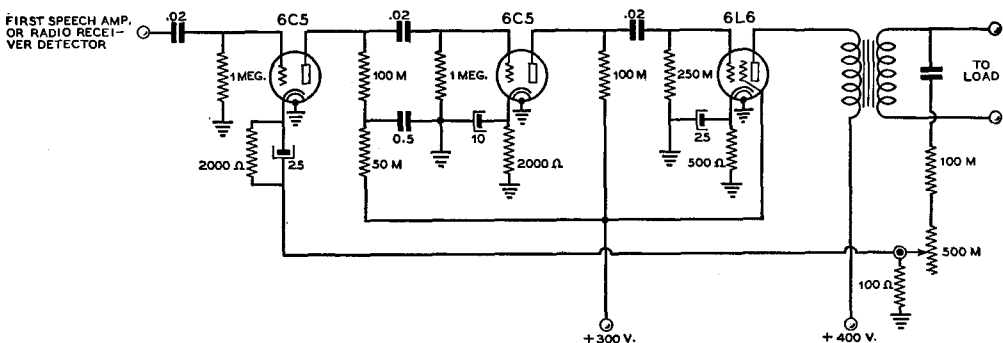

Figure 31.
THREE-STAGE DEGENERATIVE FEEDBACK AMPLIFIER.

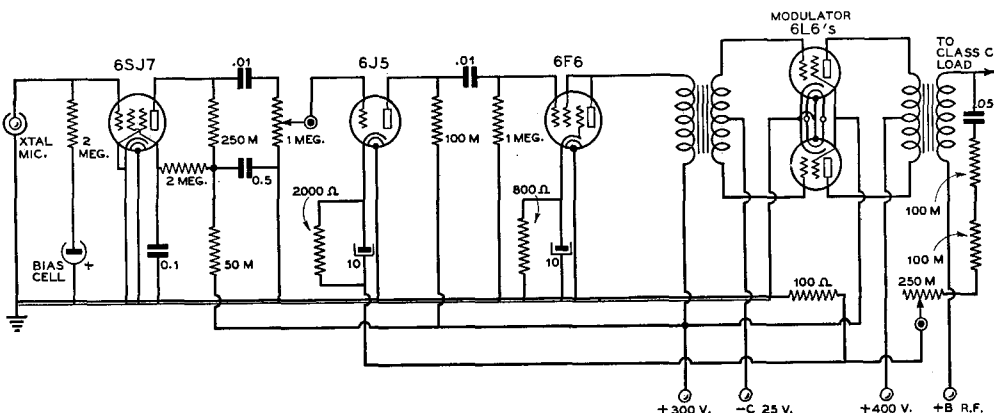

Figure 32.
45-WATT BEAM-TUBE MODULATOR WITH DEGENERATIVE FEEDBACK.

Parallel Inverse Feedback Circuit. Figure 33 shows a particularly simple and effective means of obtaining degenerative feedback around a pentode or beam tetrode output stage. The distortion at all output levels of the 6L6 amplifier stage is greatly reduced, and the permissible power output before serious distortion starts to occur is increased from about 5 watts without feedback to about 6.5 watts with the feedback circuit shown. The circuit consists simply of a high-gain audio stage, using a tube with high plate impedance, coupled to a beam-tube or pentode output stage. Degenerative feedback is accomplished by the inclusion of the resistor R in figure 33 from the plate of the output tube to the plate of the 6SJ7

Since the plate impedance of the 6L6 is lowered by the addition of feedback around

it, the correct value of load impedance is 2500 ohms. The gain of the combined two-tube circuit is intermediate between the value required for excitation of the 6L6 alone and the value required with a 6SJ7 amplifier without feedback in front of it; about 1 volt is required at the grid of the 6SJ7 for full output from the 6L6. The circuit is satisfactory for use as a low-power grid or plate modulator, as a driver for a class B stage, or to operate a speaker. A speech amplifier using this circuit is given in chapter 14.

R. F. Inverse Feedback. Modulation distortion, noises and hum level which are present on the carrier of a radiotelephone station can be reduced by inverse feedback applied as in many broadcast transmitters, but modified for amateur applications. The

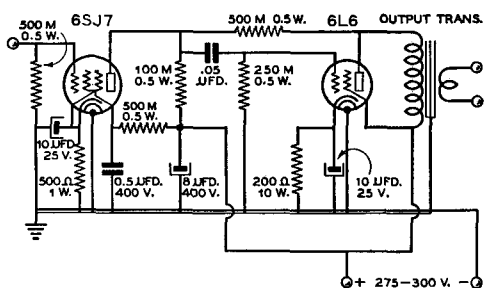

Figure 33.
6.5-WATT PARALLEL FEEDBACK AMPLIFIER-MODULATOR.

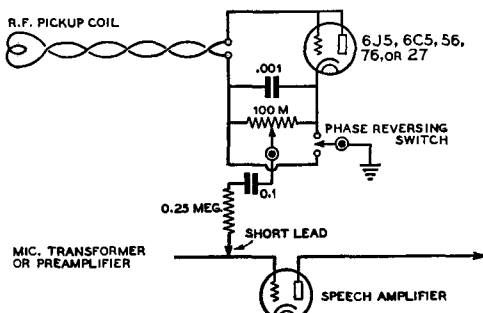

Figure 34.
DIODE CARRIER RECTIFIER WITH FEEDBACK TO AUDIO STAGE.

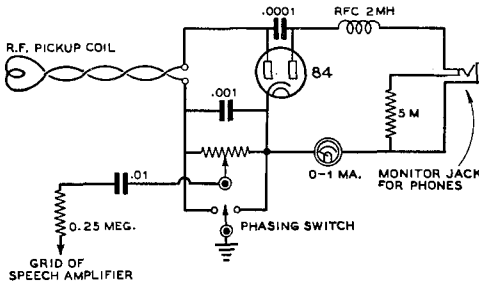

Figure 35.
DIODE CARRIER RECTIFIER FOR FEEDBACK WITH MONITORING CIRCUIT.

method consists of rectifying a small amount of the carrier signal and feeding back the audio component in reverse phase into some part of the speech amplifier. This arrangement will reduce the hum level and improve the voice quality of most amateur radiotelephone transmitters.

The amount of inverse feedback that can be applied in this manner will depend upon the available amount of excess speech amplification and the degree to which it can be carried without oscillation. The process of inverse feedback is to utilize voltages 180° out of phase over the band of frequencies of operation. Sometimes the feedback voltage may be considerably less than 180° out of phase for frequencies outside of the voice range, resulting in oscillation above the audible range, and the amount of feedback which can be applied is limited by this effect.

Two inverse feedback rectifier circuits are shown in figures 34 and 35.

Figure 34 is a simple diode rectifier which incorporates a phase-reversing switch which must be thrown to that position which will cause a slight reduction in speech amplifier gain. The actual gain of the speech amplifier

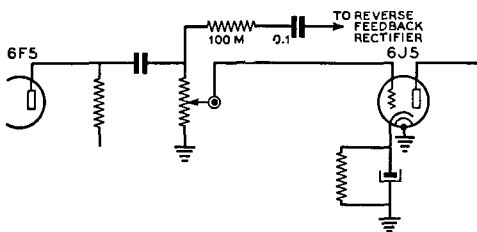

Figure 36.
PARALLEL COUPLING OF FEEDBACK INTO SPEECH AMPLIFIER.

can be increased by means of the manual gain control. The undesired noise or hum which is audible in the phone monitor will generally be reduced with the correct adjustment of the r.f. pickup coil and phase-reversing switch. Once adjusted, no additional changes are necessary unless the transmitter power output or frequency is varied.

In figure 35, a type 84 rectifier tube is connected so that one side serves as an inverse feed-back rectifier, and the other side is a standard overmodulation indicator and phone monitor.

The circuits in figures 36 and 37 show methods of connection from the feedback rectifier in to the speech amplifier.

The Diode Feedback Rectifier. The diode feedback rectifier rectifies the carrier, and any hum or noise modulation on the carrier appears as an audio voltage across the 100,000-ohm feedback control to the grid of the speech amplifier. A portion of this voltage is fed back into the speech amplifier so as to be out of phase, and thus buck out the hum or noise in the output of the radio transmitter. This may actually introduce distortion in a portion of the speech amplifier in which there is otherwise none present (commonly spoken of as being within the feedback "loop") but the final result is that the distortion or hum is cancelled out in the carrier signal of the radiotelephone transmitter. This system may be applied to transmitters which use plate, suppressor or control grid modulation. It is especially suited to transmitters employing grid modulation.

Automatic Modulation Control and Automatic Peak Limiting

It is possible to increase the average modulation level without danger of overmodulation by designing the speech amplifier to have a nonlinear amplification above a threshold

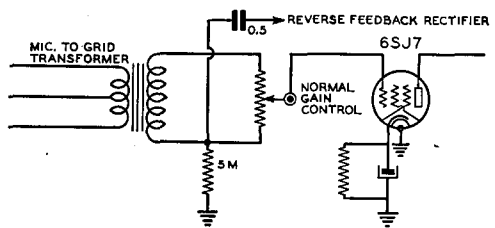

Figure 37.
SERIES COUPLING OF FEEDBACK ENERGY INTO SPEECH SYSTEM.

value corresponding to approximately 80 per cent modulation. In other words, the gain of the amplifier is constant until a signal is impressed upon it that would ordinarily modulate the transmitter over 80 per cent; then the gain of the amplifier goes down rapidly as the input signal is increased.

To increase the modulation percentage in a conventional transmitter from 80 per cent to 100 per cent requires an increase in the input signal of 2db. Broadcast stations commonly employ a compressor or peak limiter which requires 5 db increase in the audio input voltage to the amplifier in order to raise the modulation from 80 to 100 per cent. This gives 3 db compression and permits running of the gain control, without danger of over-modulation, at a setting 3 db higher than would otherwise be possible. This is equivalent to doubling the transmitter power.

Somewhat more than 3 db compression can be employed in a voice transmitter designed for communication work, but an attempt to incorporate too much compression will result in distortion so great as to affect the intelligibility.

Automatic modulation control is similar to a peak-limiting audio amplifier in effect, though the method of accomplishing the compression is somewhat different. In the a.m.c. system the output of the modulator itself is used to actuate the compression circuit, and it is somewhat more positive in action and easier to adjust. The chief disadvantage of the latter system is that it can be used only with plate modulation, while a peak-limiting a.f. amplifier can be used with either plate- or any type of grid-modulation.

Practical application of peak-limiting and a.m.c. systems will be found in the chapter, *Speech and Modulation Equipment*.

Frequency Modulation

To experimentally inclined amateurs, frequency modulation (FM) equipment offers much in the way of enjoyment and instruction. In this chapter the various points of difference between FM and amplitude modulation transmission and reception will be discussed and the advantages of FM for certain types of communication will be pointed out. Since the distinguishing features of the two types of transmission lie entirely in the modulating circuits at the transmitter and in the detector and limiter circuits in the receiver, these parts of the communication system will receive the major portion of attention.

Modulation. As previously described in this book, *modulation* is the process of altering a radio wave in accordance with the intelligence to be transmitted. The nature of the intelligence is of little importance as far as the process of modulation is concerned; it is the *method* by which this intelligence is made to give a distinguishing characteristic to the radio wave which will enable the receiver to convert it back into intelligence that determines the type of modulation being used.

Figure 1 is a three-dimensional representation of amplitude modulation of a carrier by a sine-wave modulating voltage. Actually the graph represents the transmitter *output voltage* or *current* rather than carrier amplitude, since amplitude modulation does not actually cause any variation of carrier amplitude; it merely adds sidebands spaced the modulation frequency each side of the carrier. However, for the purpose of illustration it is convenient to think of the carrier and sidebands combined to give a resultant "carrier" of constant radio frequency and varying amplitude, as shown in figure 1.

In figure 2 the carrier of figure 1 is shown frequency modulated by the same modulating voltage. The *amount* the frequency varies from its unmodulated value when modulation is applied is governed by the *amplitude*

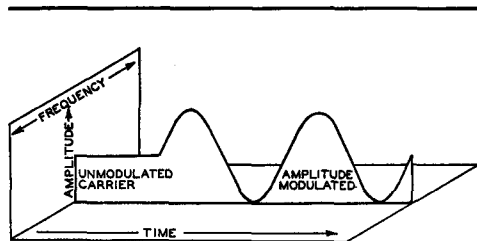

Figure 1.

AMPLITUDE MODULATION.

This three-dimensional graph, although it neglects the presence of the sidebands, gives a rough representation of an r.f. carrier with sine-wave modulation. The graph actually represents r.f. current or voltage.

Figure 2.

FREQUENCY MODULATION.

Sine-wave frequency modulation. The amplitude of the r.f. remains constant and the frequency is swung back and forth. The amount of frequency swing depends on the amount of modulation, while the number of times it swings back and forth per second depends on the modulation frequency.

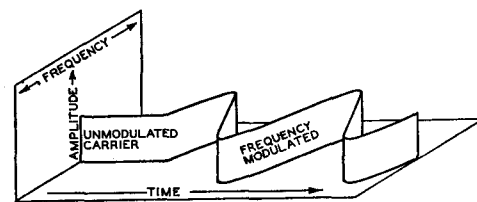

of the modulating signal. The *rate* at which the frequency varies back and forth about the carrier frequency is determined by the *frequency* of the modulating signal. A comparison of figures 1 and 2 will show readily one of the principal advantages of frequency modulation over amplitude modulation: it is not necessary to vary the transmitter power to secure modulation with the latter system.

In amateur work this advantage is probably of equal or greater importance than the widely publicized noise reduction capabilities of the system. When 100 per cent amplitude modulation is obtained, the average power output of the transmitter must be increased by 50 per cent. This additional output must be supplied either by the modulator itself, in the high-level system, or by operating one or more of the transmitter stages at such a low output level that they are capable of producing the additional output without distortion, in the low-level system. On the other hand, a frequency modulated transmitter requires an insignificant amount of power from the modulator and needs no provision for increased power output on modulation peaks.

Another advantage of FM over AM is the reduction in noise at the receiver which the system allows. If the receiver is made responsive only to changes in frequency, a considerable increase in signal-to-noise ratio is made possible through the use of FM, when the signal is of greater strength than the noise. The noise reducing capabilities of FM arise from the inability of noise to cause appreciable frequency modulation of the noise-plus-signal voltage which is applied to the detector in the receiver.

Deviation and Deviation Ratio. Unlike amplitude modulation, the term "percentage modulation" has no meaning in FM practice. There are, however, two terms, *deviation* and *deviation ratio*, which convey information concerning the character of the frequency modulated wave. Deviation is the amount of frequency change each side of the unmodulated carrier frequency which occurs when the transmitter is modulated. Deviation is ordinarily expressed in kilocycles and refers to maximum or peak deviation.

The deviation *ratio* of a transmitter is the ratio between the peak deviation under full modulation and the maximum audio frequency transmitted, both expressed in the same units. For reasons which will be described later, both the deviation and the deviation ratio used at the transmitter greatly influence the proper design of the receiver, if maximum noise suppression and maximum audio output are desired.

Bandwidth Required for FM. Early experimenters with FM held high hopes for the system as a means of reducing the bandwidth required for communication. It was thought that the r.f. carrier might be frequency modulated only a few cycles each side of the resting frequency and thus realize a system of communication in which the transmission

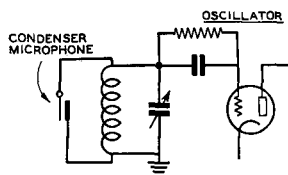

Figure 3.

SIMPLE FREQUENCY MODULATOR.

The variations in capacity of a condenser microphone as sound strikes the diaphragm will cause a corresponding variation in the oscillator frequency.

bandwidth was independent of the range of modulating frequencies. Later, mathematical analysis of the process of frequency modulation proved the fallacy of this premise, and it was shown that the bandwidth required was at least twice the highest modulation frequency. In contrast to amplitude modulation, in which only a single pair of sidebands is produced, frequency modulation produces an infinite number of sidebands. Fortunately the amplitude of the sidebands which fall outside the normal frequency "swing" under modulation will be so small that the bandwidth of the frequency modulated signal may be assumed, for practical purposes, to be only slightly greater than twice the deviation either side of center frequency under full modulation.

Modulating Circuits

A successful frequency modulated transmitter must meet two requirements: (1) The frequency deviation must be symmetrical about a fixed frequency, for symmetrical modulation voltage. (2) The deviation must be directly proportional to the amplitude of the modulation and independent of the modulation frequency. There are several methods of frequency modulation which will fulfill these requirements. Some of the methods to be shown are more suited to amateur practice than others, however.

Mechanical Modulators. The arrangement shown in figure 3 is undoubtedly the simplest of all frequency modulators. A condenser microphone is connected across the oscillator tank circuit and the variations in capacity produced by the microphone cause the oscillator frequency to vary at the frequency of the impressed sound. Since condenser microphones are difficult to obtain and the amount of r.f. voltage which may be safely impressed across them is small, the

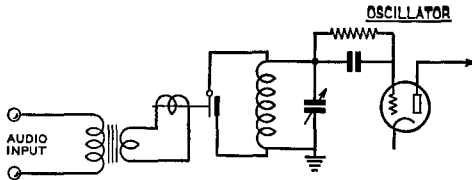

Figure 4.
ELECTRICALLY DRIVEN CON-
DENSER MODULATOR.

Certain types of audio reproducers, such as earphones and recorders, may be mechanically connected to one plate of a small variable condenser to give frequency modulation. It is important that the driving unit be of the "constant amplitude" type.

circuit is of little practical use, however. Figure 4 shows a modification of figure 3, which is more suited to practical application. Here the variable capacity device which varies the frequency consists of a condenser, one plate of which is moved by being mechanically coupled to an electro-mechanical driving unit such as loud speaker or phonograph recording head. This circuit, while practical, is seldom used because most driving units do not give frequency modulation which complies with requirement (2). The requirement is met by piezo-electric (crystal) reproducers such as earphones and recorders, however, and this type of "constant amplitude" driving unit may be used successfully.

Reactance-Resistance Modulator. Another form of frequency modulator is shown in figure 5. With this circuit the oscillator frequency is varied through the use of a fixed reactance and a variable resistance in series across the frequency controlling circuit. The reactance may be a condenser, as shown in the diagram, or an inductance, and the variable resistance may be the plate-to-cathode resistance of a vacuum tube. The tube's plate resistance is varied at an audio rate by applying an audio frequency voltage to its grid. When the modulator plate resistance and the series reactance are numerically equal, the effective reactance across the tank circuit may be varied a small amount by the modulation voltage without causing the effective resistance of the series combination to change. The amount of frequency modulation which may be obtained depends upon the amount of linear variation of the plate resistance which is possible and the amount of series reactance used. For a given percentage of modulator tube plate resistance

variation, the reactance variation of the series circuit is equal to half this percentage times the reactance used. Due to detrimental effects of the modulator tube's plate-cathode capacitance, the circuit of figure 5 is limited in usefulness to frequencies below about 2 Mc. However, where it is desired to frequency modulate an oscillator operating in the 160-meter amateur band and multiply the frequency to reach one of the FM bands, the circuit has the advantage of extreme simplicity.

Reactance - Tube Modulators. Probably the most practical method of obtaining frequency modulation, for amateur work, is through the use of a *reactance tube*. In this arrangement the modulator plate-cathode circuit is connected across the oscillator tank

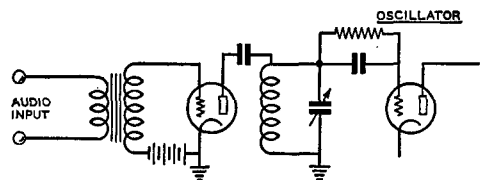

Figure 5.
REACTANCE-RESISTANCE MODULATOR.

A reactance and variable resistance such as a vacuum tube in series across a tank circuit will form a frequency modulator. The reactance may be a condenser, as shown, or it may be a coil.

circuit and made to appear as either a capacitive or inductive reactance by exciting the modulator grid with a voltage which either leads or lags the oscillator tank voltage by 90 degrees. The leading or lagging grid voltage causes a corresponding leading or lagging plate current, and the plate-cathode circuit appears as a capacitive or inductive reactance across the oscillator tank circuit. When the transconductance of the modulator tube is varied, by varying one of the element voltages, the magnitude of the reactance across the oscillator tank is varied. By applying audio modulating voltage to one of the elements, the transconductance, and hence the frequency, may be varied at an audio rate. When properly designed and operated, the reactance-tube modulator gives linear frequency modulation with deviation sufficient for all amateur purposes.

There are numerous possible configurations of the reactance-tube modulator circuit. The difference in the various arrangements lies

principally in the type of phase-shifting circuit used to give a grid voltage which is in phase quadrature with the r.f. voltage at the modulator plate.

Figure 6 is a diagram of one of the most popular forms of reactance-tube modulators. The modulator tube, which is usually a sharp cutoff pentode such as a 6J7 or 6SJ7, has its plate coupled through a blocking condenser, C_1 , to the "hot" side of the oscillator grid circuit. Another blocking condenser, C_2 , feeds r.f. to the phase shifting network R- C_3 in the modulator grid circuit. If the resistance of R is made large in comparison with the reactance of C_3 at the oscillator frequency, the current through the R- C_3 combination

since the high impedance grid circuit is prone to pick up stray r.f. and low frequency a.c. voltage and cause undesired frequency modulation. Another disadvantage to the use of a resistance in the grid circuit is that small amounts of grid current may bias the grid of the reactance tube to the point where its effectiveness as a modulator is reduced considerably.

It is almost a necessity to run a static test on the reactance-tube frequency modulator to determine its linearity and effectiveness, since small changes in the values of components and in stray capacities will almost certainly alter the modulator characteristics. A frequency-versus-control-voltage curve should be plotted to ascertain that equal increments in control voltage, both in a positive and a negative direction, cause equal changes in frequency. If the curve shows that the modulator has an appreciable amount of non-linearity, changes in bias, electrode voltages, and resistance values may be made to obtain a straight-line characteristic.

Figure 7 shows a method of connecting two 4½-volt C batteries and a potentiometer to plot the characteristic of the modulator. It will be necessary to use a zero-center voltmeter to measure the grid voltage or else reverse the voltmeter leads when changing from positive to negative grid voltage. When a straight-line characteristic for the modulator is obtained by the static test method, the capacities of the various by-pass condensers in the circuit must be kept small to retain this characteristic when an audio voltage is used to vary the frequency in place of the d.c. voltage with which the characteristic was plotted.

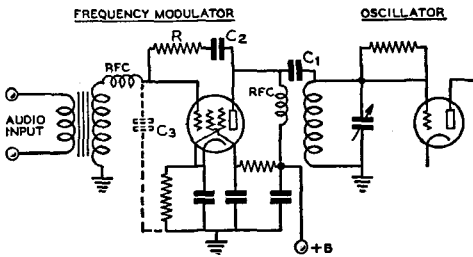

Figure 6.
REACTANCE-TUBE MODULATOR.

This is a popular form of frequency modulator. The operation of the circuit is described in the text. Typical values for the components will be found in similar circuits shown in Chapter 19.

will be in phase with the voltage across the tank circuit and the voltage across C_3 will lag the oscillator tank voltage by 90 degrees. The result of the 90-degree lagging voltage on the modulator grid is that its plate current lags the tank voltage by 90 degrees, and the reactance tube appears as an inductance in shunt with the oscillator inductance, thus raising the oscillator frequency.

The phase-shifting condenser C_3 is usually provided by the input capacitance of the modulator tube and stray capacity between grid and ground, and it will not ordinarily be found necessary to employ an actual condenser for this purpose. Resistance R will usually have a value of between 25,000 and 100,000 ohms. Either resistance or transformer coupling, as shown, may be used to feed audio voltage to the modulator grid. When a resistance coupling is used it is necessary to shield the grid circuit adequately,

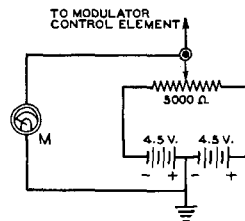

Figure 7.

This circuit allows the control characteristic of the frequency modulator to be easily checked. As the potentiometer arm is moved one way or the other from the center position a positive or negative voltage is placed on the modulator control element.

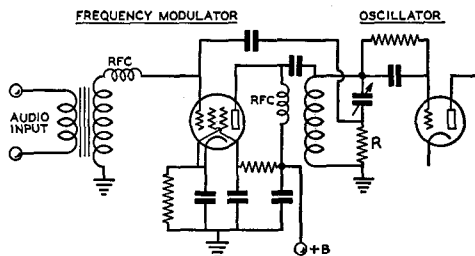

Figure 8.
REACTANCE TUBE MODULATOR.

This circuit operates similarly to the one shown in figure 6. The difference between the two lies in the method in which the r.f. grid voltage is shifted 90 degrees in phase from the r.f. plate voltage.

Another of the numerous practical reactance-tube circuits is shown in figure 8. In this circuit the 90-degree phase shift in grid excitation to the modulator is obtained by placing a resistor in series with the oscillator tank condenser. Since the current through the tank condenser leads the voltage across the tank circuit by 90 degrees, the r.f. voltage applied to the modulator grid will also lead this voltage by the same amount; the modulator plate current will lead the tank voltage and the modulator tube will appear as a condenser.

The resistor, R, may be placed in series with the tank coil, rather than the condenser, in which case the phase relationships are such that the reactance tube appears as an inductance. Too much resistance in either leg of the oscillator tank will result in such a low Q circuit that it will be impossible to maintain oscillation. Carbon resistors of from 5 to 25 ohms will provide sufficient excitation to the modulator for good sensitivity.

There are several possible variations of the basic reactance-tube modulator circuits shown in figures 6 and 8. The audio input may be applied to the suppressor grid, rather than the control grid, if desired. This method requires that the control grid be returned to ground through a rather high resistance (250,000 ohms to 1 megohm) or through an r.f. choke. Another modification is to apply the audio to a grid other than the control grid in a mixer or pentagrid converter tube which is used as the modulator. Generally it will be found that the transconductance variation per volt of control-element voltage variation will be greatest when the control (audio) voltage is applied to the control grid. In cases where it is desirable to separate completely the audio and r.f. circuits, however,

applying audio voltage to one of the other elements will often be found advantageous in spite of the somewhat lower sensitivity.

Transmission-Line Modulator. A radio-frequency transmission line is capable of giving a reactance change at one end when the terminating resistance at the other end is varied. The line length should be approximately one-eighth wave at the oscillator frequency for optimum results. Fortunately, the length is not extremely critical and the line may vary slightly from one-eighth wave. The variable resistance across the line should have a mean value approximating the characteristic impedance of the line. It may be a vacuum tube which has a plate resistance equal to the characteristic impedance of the line. It is important that the tube used across the line have a linear grid voltage-plate resistance characteristic over the region which it is intended to operate.

The variable-reactance end of the line may be placed in series with the oscillator tank circuit, as shown in the basic diagram of figure 9, or it may be inductively coupled to the oscillator tank. Ordinary lines will have such a high impedance that their insertion in series with the oscillator tank circuit will prohibit the oscillator from functioning, making it necessary to shunt the line by a low resistance, R (50 ohms, or less, depending on oscillator frequency and tank circuit Q) to maintain oscillation. The shunt resistance reduces the effectiveness of the modulator, but will usually allow sufficient net reactance variation so that the line will be an effective frequency modulator.

The transmission-line modulation system has several disadvantages which will ordinarily outweigh its advantages from the standpoint of simplicity. The difficulty of obtaining a tube with low plate resistance to match the line and yet a reasonably linear variation in plate resistance with grid voltage; the difficulty in transforming the low line impedance to a high impedance to match a high plate impedance tube, if one is used; and the difficulty in constructing a compact eighth-wave line at low frequencies and a low-loss, low impedance line at the higher frequencies are some of the more serious disadvantages.

Measurement of Deviation. When a single-frequency modulating voltage is used with a FM transmitter, the amplitudes of the various sidebands and the carrier vary widely as the deviation is varied by increasing or decreasing the amount of modulation. Since the relationship between the amplitudes of the various sidebands and carrier to the

audio modulating frequency and the deviation is known, a simple method of measuring the deviation of a frequency modulated transmitter is possible. In making the measurement, the result is given in the form of the "modulation index" for a certain amount of audio input. The modulation index is the ratio of the peak deviation to the frequency of the audio modulation. At the maximum audio frequency which the transmitter is designed to handle the modulation index and the deviation ratio are equal. The measurement is made by applying a sine-wave audio voltage of known frequency to the transmitter and increasing the modulation until the amplitude of the carrier component of the frequency modulated wave reaches zero. The modulation index for zero carrier may then be determined from the table below. As may be seen from the table, the first point of zero carrier is obtained when the modulation index has a value of 2.405, in other words when the deviation is 2.405 times the modulation frequency. For example, if a modulation frequency of 1000 cycles is used and the modulation is increased until the first carrier null is obtained the deviation will then be 2.405 times the modulation frequency, or 2.405 kc. If the modulating frequency happened to be 2000 cycles, the deviation at the first null would be 4.810 kc. Other carrier nulls will be obtained when the index is 5.52, 8.654 and at increasing values separated approximately by π . The following is a listing of the modulation index at successive carrier nulls up to the tenth:

Zero carrier point no.	Modulation index
1	2.405
2	5.520
3	8.654
4	11.792
5	14.931
6	18.071
7	21.212
8	24.353
9	27.494
10	30.635

The only equipment required for making the measurements is a calibrated audio oscillator of good wave form and a communication receiver equipped with a beat oscillator and crystal filter. The receiver should be used with its crystal filter set for a bandwidth of approximately twice the modulation frequency, to exclude sidebands spaced from the carrier by the modulation frequency. The unmodulated carrier is tuned in on the re-

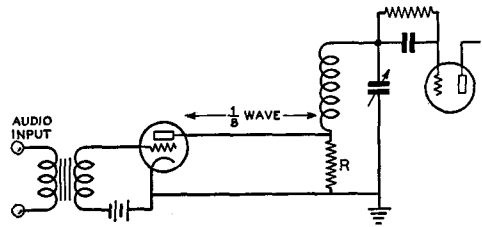

Figure 9.

TRANSMISSION-LINE MODULATOR.

An eighth-wave line shunted at one end by a vacuum tube operated as a variable resistance will give a reactance variation at the other end.

ceiver with the beat oscillator operating and modulation is then applied until the first carrier null is obtained. This first carrier null will correspond to a modulation index of 2.405, as previously mentioned. Successive null points will correspond to the indices listed in the table. A volume indicator in the transmitter audio system may be used to measure the audio level required for different amounts of deviation and calibrated in terms of frequency deviation. If the measurements are made at the fundamental frequency of the oscillator it will be necessary to multiply the frequency deviation by the harmonic upon which the transmitter is operating, of course. It will probably be most convenient to make the determination at some frequency intermediate between that of the oscillator and that at which the transmitter is operating.

Stabilization. Due to the presence of the frequency modulator, the stabilization of an FM oscillator in regard to voltage changes is considerably more involved than in the case of a simple self-controlled oscillator for transmitter frequency control. If desired, the oscillator itself may be made perfectly stable under voltage changes, but the presence of the frequency modulator destroys the beneficial effect of any such stabilization. It thus becomes desirable to apply the stabilizing arrangement to the modulator as well as the oscillator. If the oscillator itself is stable under voltage changes, or in other words self-compensated by some means such as the use of an electron-coupled circuit, it is only necessary to apply voltage-frequency compensation to the modulator. Stabilized power supply arrangements suitable for use on the modulator or both modulator and oscillator are described fully in *Chapter Fifteen*.

Another method of oscillator stabilization makes use of a discriminator circuit. This

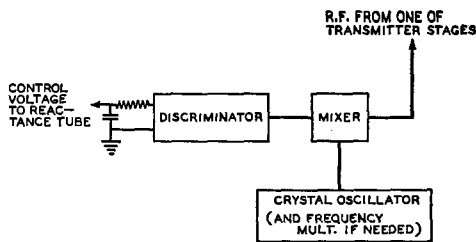

Figure 10.

FM OSCILLATOR STABILIZING ARRANGEMENT.

The frequency modulated oscillator may be stabilized against undesired frequency shift by converting the transmitter signal to a lower frequency and applying it to a discriminator. If the transmitter drifts, the voltage from the discriminator restores it to the correct frequency. An R-C filter is used to remove the audio modulation from the discriminator output.

arrangement stabilizes the frequency against changes arising from any cause (except the desired modulation) by comparing the oscillator frequency with a crystal controlled standard and applying the proper compensating voltages. A block diagram of this method is shown in figure 10. Output from one of the stages of the transmitter is mixed with the output of a crystal oscillator to give an "intermediate frequency" output which is applied to a conventional discriminator. The discriminator, which will be more completely described later in this chapter, is a circuit arrangement to produce an output voltage which depends on the frequency of the r.f. applied to it.

The d.c. voltage produced by the discriminator is applied to a reactance tube tied across the oscillator tank circuit. As the average or "center" frequency varies one way or the other from the correct value, a positive or negative voltage appears across the discriminator load resistors. When this voltage is placed on the control element of the reactance tube, the center (mid-modulation or unmodulated) radio frequency is restored to a value which gives zero voltage output from the discriminator. Ordinarily the reactance tube which takes care of the frequency correction will also be used as the modulator, and the frequency stabilizing voltage may be applied in series with the audio voltage or, alternatively, it may be applied to another of the tube elements. The audio output of the discriminator must be removed by a simple R-C filter so that the compensating voltage is direct current without superimposed audio. Obviously the stability of the complete arrangement is de-

pendent upon the stability of the discriminator components under temperature and humidity changes and upon the stability of the crystal oscillator. Ordinarily the stability of the crystal oscillator will be sufficiently great that the discriminator will be the limiting factor in the amount of stabilization obtainable, making it necessary to use discriminator components (especially the tuned input transformer) of good quality.

The frequency of the crystal used in the stabilizing circuit will depend upon the frequency at which the discriminator operates and the frequency of the stage in the transmitter from which the stabilizer signal is taken. If a b.c. replacement type discriminator transformer designed for a frequency in the 400-500 kc. range is used, the r.f. input for the stabilizer may be obtained from the transmitter oscillator stage, or, if more sensitivity is desired, from the plate circuit of the frequency multiplier following the oscillator. The crystal oscillator must operate on a frequency such that its fundamental or one of its harmonics falls at a frequency which differs from that of the crystal-controlled r.f. applied to the stabilizer by an amount equal to the discriminator frequency. If the required crystal frequency falls higher than is easily obtainable with a crystal or its second harmonic, it may be necessary to use a frequency multiplier following the crystal oscillator.

RECEIVING FREQUENCY MODULATION

In contrast with the transmitter, where the use of FM greatly simplifies the modulation problem, the use of FM necessitates a receiver somewhat more complicated than would be necessary for amplitude modulation. While the simple superregenerative type receiver will give fair results with FM transmissions, it requires a rather large transmitter swing under modulation to realize an audio output comparable to what would be obtained from an amplitude modulated signal of the same strength.

The FM receiver must have, first of all, a bandwidth sufficient to pass the range of frequencies generated by the FM transmitter. And since the receiver must be a superheterodyne if it is to have good sensitivity at the frequencies to which FM is restricted, i.f. bandwidth is an important factor in its design.

The second requirement of the FM receiver is that it incorporate some sort of device for converting frequency changes into ampli-

tude changes, in other words a detector operating on frequency variations rather than amplitude variations. The third requirement, and one which is necessary if the full noise reducing capabilities of the FM system of transmission are desired, is a limiting device to eliminate amplitude variations before they reach the detector. A block diagram of the essential parts of an FM receiver is shown in figure 11.

The Frequency Detector. The simplest device for converting frequency variations to amplitude variations is an "off-tune" resonant circuit, as illustrated in figure 12. With the carrier tuned in at point "A," a certain amount of r.f. voltage will be developed across the tuned circuit, and, as the frequency is varied either side of this frequency by the modulation, the r.f. voltage will increase and decrease to points "C" and "B" in accordance with the modulation. If the voltage across the tuned circuit is applied to a rectifier, the rectified current will vary in accordance with the modulation, the amplitude of the variation being proportional to the deviation of

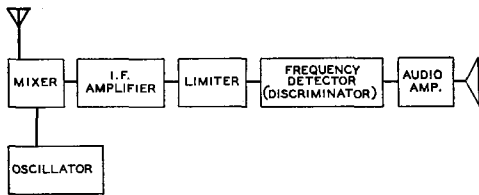

Figure 11. RECEIVER BLOCK DIAGRAM.

Up to the amplitude limiter stage, the FM receiver is similar to an AM receiver, except for a somewhat wider i.f. bandwidth. The limiter removes any amplitude modulation and the frequency detector following the limiter converts frequency modulation into amplitude variations.

Figure 12. "OFF TUNE" FREQUENCY DETECTOR.
A portion of the resonance characteristic of a tuned circuit may be used to convert frequency variations into amplitude variations.

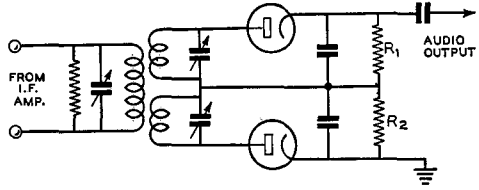
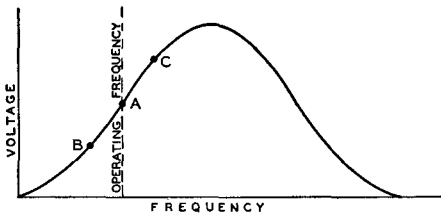

Figure 13. TRAVIS DISCRIMINATOR.

the signal and the rate being equal to the modulation frequency. It is obvious from figure 12 that only a small portion of the resonance curve is usable for linear conversion of frequency variations into amplitude variations, since the linear portion of the curve is rather short. Any frequency variation which exceeds the linear portion will cause distortion of the recovered audio.

Travis Discriminator. Another form of frequency detector or *discriminator* which utilizes the resonance characteristic of tuned circuits is shown in figure 13. In this arrangement two tuned circuits are used, with their resonant frequencies spaced slightly more than the expected transmitter "swing" apart. Their outputs are combined in a differential rectifier so that the voltage across the series load resistors, R_1 and R_2 , is equal to the algebraic sum of the individual output voltages of each rectifier. When a signal at the i.f. mid-frequency is received, the voltages across the load resistors are equal and opposite and the sum voltage is zero. As the r.f. signal varies from the mid-frequency, however, these individual voltages become unequal and a voltage having the polarity of the

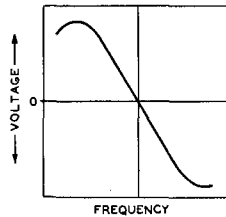

Figure 14. DISCRIMINATOR VOLTAGE-FREQUENCY CURVE.

At its "center" frequency the discriminator produces zero output voltage. On either side of this frequency it gives a voltage of a polarity and magnitude which depend on the direction and amount of frequency shift.

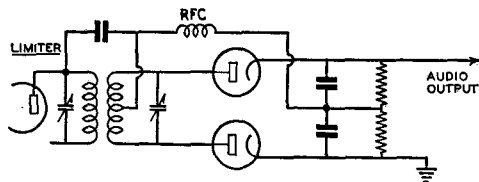

Figure 15.

FOSTER-SEELEY DISCRIMINATOR.

This discriminator depends on the phase relationships of inductively coupled tuned circuits for its operation.

largest voltage and equal to the difference between the two voltages appears across the series resistors and is applied to the audio amplifier. The relationship between frequency and discriminator output voltage is shown in figure 14.

Foster-Seeley Discriminator. The most widely used form of discriminator is that shown in figure 15. This type of discriminator yields an output-voltage-versus-frequency characteristic similar to that shown in figure 14. Here again the output voltage is equal to the algebraic sum of the voltages developed across the load resistors of the two diodes, the resistors being connected in series to ground. However, this *Foster-Seeley* discriminator requires only two tuned circuits instead of the three used in the previous discriminator. The operation of the circuit results from the phase relationships existing in coupled circuits tuned to the same frequency. In effect, as a close examination of the circuit will reveal, the primary circuit is in series, for r.f., with each half of the secondary to ground. When the received signal is at the resonant frequency, the r.f. voltage across the secondary is 90 degrees out of phase with that across the primary, due to the inductive coupling between the two circuits. Since each diode is connected across one half of the secondary winding and the primary winding in series, the resultant r.f. voltages applied to each are equal and the voltages developed across each diode load resistor are equal and of opposite polarity. Hence the net voltage between the top of the load resistors and ground is zero. This is shown vectorially in figure 16A, where the resultant voltages R and R' which are applied to the two diodes are shown to be equal. If, however, the signal varies from the resonant frequency, the 90-degree phase relationship no longer exists between primary and secondary. The result of this effect is shown in figure 16B, where the secondary r.f. voltage

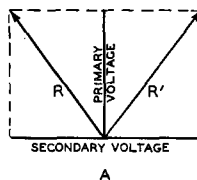

A

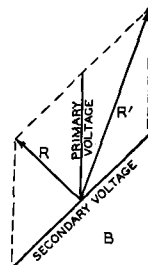

B

Figure 16.

DISCRIMINATOR VECTOR DIAGRAM.

is no longer 90 degrees out of phase with respect to the primary voltage. The resultant voltages applied to the two diodes are now no longer equal, and a d.c. voltage proportional to the difference between the r.f. voltages applied to the two diodes will exist across the series load resistors. As the signal frequency varies back and forth across the resonant frequency of the discriminator, an a.c. voltage of the same frequency as the original modulation and proportional to the deviation is developed and passed on to the audio amplifier.

Limiters. The limiter in an FM receiver serves to remove amplitude modulation and pass on to the discriminator a frequency modulated signal of constant amplitude; a typical circuit is shown in figure 17. The limiter tube is operated as an i.f. stage with very low plate voltage and with grid leak bias, so that it overloads quite easily. Up to a certain point the output of the limiter will increase with an increase in signal. Above this point, however, the limiter becomes overloaded and further large increases in signal will not give any increase in output. To operate successfully the limiter must be supplied with a large amount of signal, so that the amplitude of its output will not change for rather wide variations in amplitude of the signal. Noise, which causes little frequency modulation but much amplitude modulation of the received signal is virtually wiped out.

The voltage across the grid resistor, R_1 , varies with the amplitude of the received signal, and for this reason conventional amplitude modulated signals may be received on the FM receiver by connecting the input of the audio amplifier to the top of this resistor, rather than to the discriminator output. When properly filtered by a simple R-C circuit the voltage across R_1 may also be used as a.v.c. voltage for the receiver, as shown in the diagram.

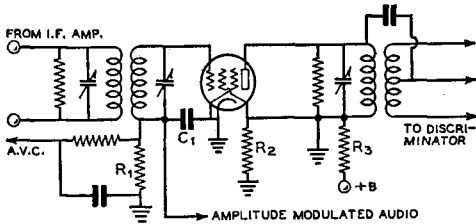

Figure 17.

LIMITER CIRCUIT.

The limiter stage overloads easily, and when overloaded will not reproduce amplitude variations. R_1 may have a value of from 250,000 ohms to 1 megohm. Condenser C_1 should be rather small, about .0001 μ fd. Resistors R_2 and R_3 should be proportioned so that the plate and screen voltage is from 10 to 30 volts.

Receiver Design Considerations. One of the most important factors in the design of the receiver is the frequency swing which it is designed to handle. It will be apparent from figure 14 that if the straight portion of the discriminator circuit covers a wider range of frequencies than those over which the transmitter is swung, the audio output will be reduced from the maximum value of which the receiver is capable. In this respect the term "modulation percentage" is more applicable to the FM receiver than it is to the transmitter, since the "modulation capability" of the communication system is limited by the receiver bandwidth and the discriminator characteristic; full utilization of the linear portion of the characteristic amounts, in effect, to "100 per cent" modulation. This means that some sort of standard must be agreed upon, for any particular type of communication, to make it unnecessary to vary the transmitter swing to accommodate different receivers.

Two considerations influence the bandwidth suitable for any particular type of communication. These are the maximum audio frequency which the system will handle and the deviation ratio which will be employed. For voice communication the maximum audio frequency is more or less fixed at 3000 to 4000 cycles. In the matter of de-

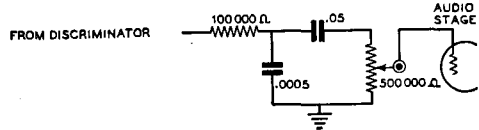

Figure 18.

LOW PASS FILTER.

A low-pass filter is necessary in the FM receiver to remove high frequency noise components.

viation ratio, however, the amount of noise suppression which the FM system will provide is influenced by the ratio chosen, since the improvement in signal-to-noise ratio which the FM system shows over amplitude modulation is equivalent to a constant multiplied by the deviation ratio. (This assumes that the signal is somewhat stronger than the noise at the receiver, as the advantages of FM in regard to noise suppression disappear when the signal-to-noise ratio approaches unity.)

Broadcast practice is to use a deviation ratio of approximately five, the maximum audio frequency transmitted being 15,000 cycles and the deviation at full modulation being approximately 75 kc., or a total "swing" of 150 kc. When this ratio is applied to a voice-communication system the total swing becomes 30 to 40 kc., which is a practical value, as the design of an i.f. amplifier to pass a band this wide is not particularly difficult.

Audio Bandwidth. To realize the full noise reducing capabilities of FM it is essential that the pass band of the audio section of the receiver be limited to that necessary for communication. The noise output of the discriminator is proportional to the audio frequency of the noise, and the improvement in signal-to-noise ratio depends almost entirely on receiver deviation ratio, or the ratio between one-half the r.f. bandwidth and the audio bandwidth. A suitable arrangement for removing frequencies higher than those necessary for communication is shown in figure 18. The 100,000-ohm resistor and the .0005- μ fd. condenser reduce the high frequency audio passed to the audio amplifier.

CHAPTER TEN

Transmitting Tubes

With the exception of small, receiver type tubes, all tubes for low and medium-power transmitting applications are shown by manufacturer's type number in numerical order regardless of prefix or suffix letters.

Certain of the tubes listed (800, 830-B, 865, etc.) are manufactured primarily for replacement of such tubes already in use, as they have been superseded by improved models which cost less than their prototype. Therefore, when choosing tubes for a trans-

mitter which is being designed, it is wise to study the characteristics and price of all tubes in the same class before making a decision. Flat plate tubes which necessarily have comparatively high interelectrode capacities (810, etc.) generally are easier to drive than other tubes at low frequencies, but do not work as well at u.h.f. as do "low C" tubes having a cylindrical plate (35T, TW-75, HK-54, 808, etc.). However, all types operate well on frequencies below 7.0 Mc.

TRANSMITTING TUBE TYPES BY PLATE DISSIPATION

2.5	Watts—RK33	65	Watts—HY51A, HY51B, HY-51Z, 203Z, 814 (RCA)
6	Watts—RK24, 1610	70	Watts—35T, S35T, WE282A
10	Watts—RK23, RK25, RK25B, RK34, RK45, 802	75	Watts—TW75, HF100, TF100, ZB120, HK257, 845 (RCA)
12	Watts—RK44, 837, 841	80	Watts—828
15	Watts—RK10, HY60, RK100, WE307A, 832, 841 (RCA), 843, 844, 865	85	Watts—211 (Taylor), WE242A
20	Watts—T20, TZ20, 801, 801A, 1608	100	Watts—RK36, RK38, RK48, 100TH, S100TH, 100TL, 203A, 211 (RCA), 211C, 211D, HK-254, 813, 838, 850, 852, 860 (RCA)
21	Watts—T21, RK49	125	Watts—T125, 211C (Amperex), 211H (Amperex), 803, 805
25	Watts—RK11, RK12, HK24, HY25, RK28, RK30, RK39, RK41, HY61, WE254B, 807, 809, 1624, 1623	150	Watts—TW150, HD203A, HK-354, HK354C, HK354D, HK-354E, HK354F, 806, 810
30	Watts—WE316A	160	Watts—HF200
35	Watts—800	200	Watts—T200, HF300, 814, 822 (Taylor)
40	Watts—RK18, RK20A, RK31, HY40, HY40Z, T40, TZ40, RK46, HY69, WE300A, 804, 829, 1628	250	Watts—204A, 250TH, S250-TH, 250TL
50	Watts—RK32, RK35, RK37, RK47, HK54, WE304B, 808, 834	275	Watts—WE212E
55	Watts—T55, 811, 812	300	Watts—HK654, 833
60	Watts—RK51, WE305A, 830B,	350	Watts—WE270A
62.5	Watts—RK52	400	Watts—831, 849, 861
		450	Watts—450TH, 450TL

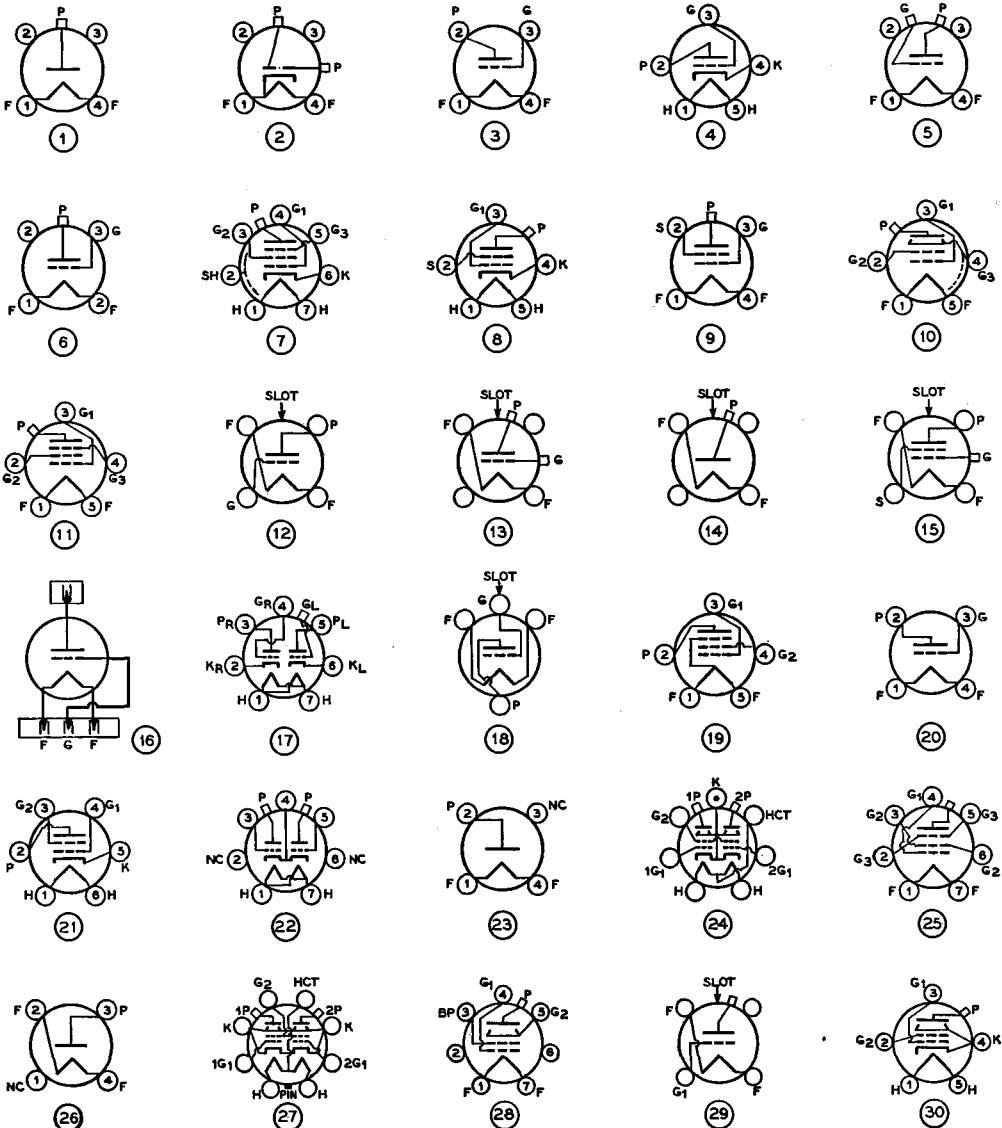

TRANSMITTING TUBE SOCKET CONNECTIONS—BOTTOM VIEWS.

REFERENCES INDICATED IN FOLLOWING TUBE TABLES

¹Designed specifically for u.h.f. application.

²The suffix "H" after the voltage indicates an indirectly-heated cathode.

³M—medium; O—octal; L—large. The final numbers refer to the proper socket connection sketch above.

⁴Grid driving requirements for r.f. service are subject to wide variation depending upon impedance of plate circuit. Values given are for typical plate impedances. A reserve of excitation power should always be available, and allowance should be made for appreciable circuit losses at ultra high frequencies when choosing a driver tube.

⁵Manufactured by the following: Amperex (Amp.), Eimac, Heintz & Kaufman Ltd. (H&K), Hytron, Raytheon (Ray.), RCA Manufacturing Co. (RCA), Sheldon, Taylor, and Western Electric (W.E.). Certain types marked RCA are also manufactured by Westinghouse and General Electric and sold at the same prices indicated.

⁶Intermittent commercial and amateur service ratings. For use where long tube life and reliability of operation are more important than tube cost, refer to more conservative ratings as given in manufacturer's data sheets.

⁷Plate current is the maximum signal value for Class-B and Class-AB audio applications.

⁸Grid current is the maximum signal value for Class-B audio application.

⁹Plate-screen modulation is assumed in the Class-C telephony application of tetrodes and pentodes.

¹⁰Bias must be adjusted at no signal for maximum rated dissipation.

¹¹No-signal value for RK-100.

¹²Characteristics are per-section unless otherwise noted.

¹³Characteristics are for two tubes unless otherwise stated.

¹⁴This type manufactured also by Sheldon.

¹⁵Socket is provided with built-in bypass condensers.

Mfr. No.	Type	Cathode		Base ³ and Connections	Max. Plate Voltage	Max. Plate Current (ma.)	Triode Mu or Max. Screen Voltage	Max. D. C. Control Grid Current (ma.)	Max. Plate Dissipation (Watts)	Max. Screen Dissipation (Watts)	Interelectrode Capacitances μ fd.s.			Typical ⁹ Operation	Plate Volts	Control Grid Bias	Screen Volts	Suppressor Volts	Plate ⁷ Current (ma.)	D. C. ⁸ Control Grid Current (ma.)	Screen Current (ma.)	Grid Driving Power (Approx. Watts)	Load Imped. P to P (Ohms)	Power Output (Watts) typical	Mfr.	Price
		G-F In-put	P-F Out-put								G-P Feed-back															
RK-10	Triode	7.5	1.25	4-pin M. 3	450	65	8	15	15					Class-C Telephony	450	-100			65	15		3.2		19	Ray.	
														Class-C Telephony	350	-100			50	12		2.2		12		
RK-11	Triode	6.3	3.0	4-pin M. 6	750	105	20	35	25					Class-C Telephony	750	-120			105	21		3.2		55	Ray.	2.50
														Class-C Telephony	600	-120			85	24		3.7		38		
RK-12	Triode	6.3	3.0	4-pin M. 6	750	105	80	40	25					Class-C Telephony	750	-100			105	35		5.2		55	Ray.	2.50
														Class-C Telephony	600	-100			85	27		3.8		38		
														Class-B Audio	750	0			200	65		3.4	9600	100		
RK-18	Triode	7.5	3.0	4-pin M. 6	1250	100	18	40	40					Class-C Telephony	1250	-160			100	12		2.8		95	Ray.	2.50
														Class-C Telephony	1000	-140			80	13		3.1		64		
														Class-B Audio	1250	-60			220	60		9	18000	190		
RK-19	Full-Wave Hi-Vacuum Rectifier	7.5H	2.5	4-pin M. 2	3500 Peak Inverse	600 Peak								Full-Wave Rectifier	1250				200						Ray.	
RK-20A	Pentode	7.5	3.25	5-pin M. 11	1250	92	300	15	40	15	14	12	0.01	Class-C Telephony	1250	-100	300	+45	92	11.5	36	1.6		84	Ray.	15.00
														Class-C Telephony	1000	-100	300	0	75	10	30	1.3		52		
T-20	Triode	7.5	1.75	4-pin M. 6	750	85	20	200	20					Class-C Telephony	750	-85			85	18		3.6		44	Taylor	2.25
														Class-C Telephony	750	-135			70	15		3.6		38		
														Class-C Telephony	750	-40			85	28		3.75		44		
TZ-20	Triode	7.5	1.75	4-pin M. 6	750	85	62	30	20					Class-C Telephony	750	-100			70	23		4.8		38	Taylor	2.25
														Class-B Audio	750	0			170			2.6	9000	80		
KY-21	Grid Control Mercury Vapor Rectifier	2.5	10	4-pin M. 6	11,000 Peak Inverse	3000 Peak								Grid-Controlled Rectifier	3500				1500 (2 tubes)					Eimac	10.00	
RK-21	Half-Wave Hi-Vacuum Rectifier	2.5H	4.0	4-pin M. 1	3500 Peak Inverse	600 Peak								Diode Half-Wave Hi-Vacuum Rectifier	1250 per plate				200					Ray.		

RX-21	Mercury Vapor Rectifier	2.5	10	4-pin M. 1	11,000 Peak Inverse	3000 Peak									Half-Wave Rectifier	3500					1500 Output Current						Eimac		
T-21	Beam Power Tetrode	6.3H	0.9	6-pin M. 21	400	95	300	5	21	3.5	11.5	11.5	1.4	Class-C Telegraphy	400	-45	300				95	5	16	0.4		17	Taylor	1.95	
														Class-C Telephony	400	-45	300				65	5	16	0.4		17			
RK-22	Full-Wave Hi-Vacuum Rectifier	2.5H	8.0	4-pin M. 2	3500 Peak Inverse	600 Peak								Full-Wave Rectifier	1250						200 Output Current					Ray.			
RK-23	Pentode	2.5H	2.0	7-pin M. 7	500	60	250	10	10	8.0	10	10	0.2	Class-C Telegraphy	500	-90	200	+45				55	4	38	0.5		22	Ray.	4.50
														Class-C Telephony	400	-90	150	0	43	6	30	0.8		13.5					
														Sup.-Mod. Telephony	500	-125	200	-45	31	4	39	0.5		6					
HK-24	Triode	6.3	3.0	4-pin S. 6	2000	75	25	25	25		2.5	0.4	1.7	Class-C Telegraphy	2000	-140					56	18		4.0		90	H&K	3.50	
														Class-C Telephony	1500	-145			50	25		5.5		60					
														Class-B Audio	1250	-42			136			4.2		120					
RK-24	Triode	2.0 d.c.	0.12	4-pin S. 3	180	20.0	8	6.0	1.5					Class-C Amp.-Osc.	180	-45				16.5	6.0		0.5		2.0	Ray.	2.25		
HY-25	Triode	7.5	2.25	4-pin M. 6	800	75	55	25	25		4.2	1.0	4.6	Class-C Telegraphy	750	-45					70	15		2.0		42	Hytron	1.45	
														Class-C Telephony	700	-45			75	17		5.0		40					
														Class-B Audio	800	-9.0			140			2.7	2250	75					
RK-25 RK-25B	Pentode	6.3H	0.9	7-pin M. 7	500	60	250	10	10	8.0	10	10	0.2	Class-C Telegraphy	500	-90	200	+45				55	4	38	0.5		22	Ray.	3.95
														Class-C Telephony	400	-90	150	0	43	6	30	0.8		13.5					
														Sup.-Mod. Telephony	500	-125	200	-45	31	4	39	0.5		6					
RK-28	Pentode	10	5.0	Giant 5-pin 11	2000	150	400	25	100	35	15	15	0.02	Class-C Telegraphy	2000	-100	400	+45				150	13	55	2.0		210	Ray.	28.50
														Class-C Telephony	1500	-100	400	+45	135	13	52	2.0		155					
														Sup.-Mod. Telephony	2000	-100	400	-45	85	13	65	1.8		60					
RK-30	Triode	7.5	3.25	4-pin M. 5	1250	80	15	25	35		2.75	2.75	2.5	Class-C Telegraphy	1250	-180					90	18		5.2		85	Ray.		
														Class-C Telephony	1000	-200			80	15		4.5		60					
														Class-B Audio	1250	-70			130	26		3.4	21000	106					
Twin 30 ²	Dual Triode	6	4	4-pin M.	1500	85 ea. Sect.	32	30 ea. Sect.	30 ea. Sect.		1.9	0.2	2	Class-C Telegraphy	1500	-100					150	40		15		175	Eimac	13.50	
														Class C Telephony	1250	-100			135	40		15		125					

Mfr. No.	Type	Cathode		Base ³ and Connections	Max. Plate Voltage	Max. Plate Current (ma.)	Triode Mu or Max. Screen Voltage	Max. D.C. Control Grid Current (ma.)	Max. Plate Dissipation (Watts)	Max. Screen Dissipation (Watts)	Interelectrode Capacitances μ fd.			Typical ⁹ Operation	Plate Volts	Control Grid Bias	Screen Volts	Suppressor Volts	Plate ⁷ Current (ma.)	D.C. ⁸ Control Grid Current (ma.)	Screen Current (ma.)	*Grid Driving Power (Approx. Watts)	Load Imped. P to P (Ohms)	Power Output (Watts) typical	Mfr.	Price	
		G-F In-put	P-F Out-put								G-P Feed-back																
HY-31Z	Twin Triode	6.3	2.5	4-pin M.	500	150	45	30	30		5	1.9	5	Class-B Audio	500	0			150	30		1.8	7000	51	Hytron		
RK-31	Triode	7.5	3.0	4-pin M. 6	1250	115	75	76	40		7	2.0	10	Class-C Telephony	1250	-80			100	30		3.9		90	Ray.	10.00	
														Class-C Telephony	1000	-80			100	28		3.5		70			
														Class-B Audio	1250	0			220	76		4.4	18000	190			
RK-32	Triode	7.5	3.25	4-pin M. 5	1250	100	11	25	50		2.5	0.7	3.4	Class-C Telephony	1250	-225			100	14		4.8		90	Ray-		
														Class-C Telephony	1000	-310			100	21		8.7		70			
RK-33	Twin Triode	6.3	0.6	7-pin S 17	250	20 ea. Sect.	10	6.0	2.5	Left Triode Right Triode	3.0	2.5	3.0	Class-C Amp.-Osc.	250	-60			20	6.0		0.54		3.5	Ray-		
																										2.0	2.5
RK-34 ¹	Twin Triode	6.3	0.8	7-pin M. 22	300	80 both triodes	30	20	10 both triodes		4.2 ea.	0.8 ea.	2.7 ea.	P.P. Class-C Amp.-Osc.	300	-36			80	20		1.8		16	Ray-	3.50	
														Class-B Audio	300	-15			70	12		0.5	10000	13			
35-T	Triode	5.0	4.0	4-pin M. 6	2000	150	30	35	70		4	0.2	1.9	Class-C Telephony	2000	-150			150	30		30		225	Eimac ¹⁴	6.00	
														Class-C Telephony	1500	-120			100	30		15		120			
														Class-B Audio	1500	-40								12800			230
														Same as 35-T													
35-TG	Triode	5.0	4.0	4-pin M. 5	2000	150	30	35	70		1.9	0.2	1.7	Class-C Telephony	1500	-250			115	15		5	120	Ray.			
																									Class-C Telephony	1250	-250
RK-35	Triode	7.5	4.0	4-pin M. 5	1500	125	9	20	50		3.5	0.4	2.7	Class-C Telephony	2000	-360			150	30		15		200	Ray.		
														Class-C Telephony	2000	-360			150	30		15		200			
RK-36	Triode	5.0	8.0	4-pin M. 5	3000	165	14	35	100		4.5	1.0	5.0	Class-C Telephony	1500	-130			115	30		7.0		122	Ray.		
														Class-C Telephony	1250	-150			100	23		5.6		90			
RK-37	Triode	7.5	4.0	4-pin M. 5	1500	125	30	35	50		3.5	0.2	3.2	Class-C Telephony	2000	-200			160	30		10		225	Ray.	6.95	
														Class-C Telephony	2000	-200			160	30		10		225			
RK-38	Triode	5.0	8.0	4-pin M. 5	3000	165	30	40	100		4.6	0.9	4.3	Class-C Telephony	2000	-200			160	30		10		225	Ray.	13.50	
														Class-B Audio	2000	-52			265	39		5.8	16000	330			

RK-39	Beam Power Tetrode	6.3	0.9	5-pin M. 30	600	100	300	5.0	25	3.5	13	10	0.2	Class-C Telephony	600	-90	300		93	3.0	10	0.38		36	Ray.	3.50
														Class-C Telephony	475	-50	250		85	2.5	9.0	0.2		26		
														Class-AB ² Audio	600	-30	300		200			0.4	6660	80		
HY-40	Triode	7.5	2.25	4-pin M. 6	1000	115	25	25	40		5.8	1.8	6.3	Class-C Telephony	1000	-90			115	20		5.0		86	Hy-tron	2.75
														Class-C Telephony	850	-90			90	15		3.5		52		
														Class-B Audio	1000	-22.5			250				9000	185		
HY-40Z	Triode	7.5	2.5	4-pin M. 6	1000	115	80	30	40		5.8	1.8	6.3	Class-C Telephony	1000	-27.5			115	25		5.0		86	Hy-tron	2.75
														Class-C Telephony	850	-30			90	30		7.0		52		
														Class-B Audio	1000	0			250	51			6900	185		
T-40	Triode	7.5	2.5	4-pin M. 6	1500	150	25	40	40		4.5	0.8	4.8	Class-C Telephony	1500	-140			150	28		9.0		158	Taylor	3.50
														Class-C Telephony	1250	-115			115	20		5.25		104		
														Class-C Telephony	1500	-90			150	38		10		165		
TZ-40	Triode	7.5	2.5	4-pin M. 6	1500	150	62	45	40		4.8	0.8	5.0	Class-C Telephony	1250	-100			125	30		7.5		116	Taylor	3.50
														Class-B Audio	1500	-9.0			250			6.0	12000	250		
														Class-C Telephony	600	-90	300		93	3.0	10	0.38		36		
RK-41	Beam Power Tetrode	2.5H	2.4	5-pin M. 30	600	100	300	5.0	25	3.5	13	10	0.2	Class-C Telephony	475	-50	250		85	2.5	9.0	0.2		26	Ray.	3.50
RK-42	Triode	1.5	0.06	4-pin S. 3	150	7.5	8				3	2.1	6.0	Class-A Audio	180	-13.5			3.9						Ray.	1.10
RK-43	Twin Triode	1.5	0.12	6-pin S.	135	15 (both triodes)	13	3.0			1.9	2.1	4.2	Class-C Amp.-Osc.	135	-20			14	3.0		0.2		1.25	Ray.	1.50
														Class-B Audio	135	-6.0			12.5	1.0		0.027	24000	0.95		
RK-44	Pentode	12.6H	0.7	7-pin M. 7	500	80	200	8.0	12	8.0	16	10	0.2	Class-C Telephony	500	-75	200	+40	60	4.0	15	0.4		22	Ray.	
														Class-C Telephony	400	-40	140	+40	45	5.0	20	0.3		11		
RK-45	Pentode	12.6H	0.45	7-pin M. 7	500	60	250	10	10	8.0	10	10	0.02	Class-C Telephony	500	-90	200	+45	55	4.0	38	0.5		22	Ray.	
														Class-C Telephony	400	-90	150	0	43	6.0	30	0.8		13.5		
RK-46	Pentode	12.6	2.5	5-pin M. 11	1250	92	300	15	40	15	14	12	0.1	Class-C Telephony	1250	-100	300	+45	92	11.6	36	1.6		84	Ray.	
														Class-C Telephony	1000	-100	300	0	75	10	30	1.3		52		
RK-47	Beam Power Tetrode	10	3.25	5-pin M. 10	1250	150	300	10	50	10	13	10	0.12	Class-C Telephony	1250	-70	300		138	7.0	14	1.0		120	Ray.	17.50
														Class-C Telephony	900	-120	250		90	7.5	23	1.2		55		
RK-48	Beam Power Tetrode	10	5.0	Giant 5-pin 10	2000	180	400	25	100	22	17	13	0.13	Class-C Telephony	2000	-100	400		180	6.5	40	1.0		250	Ray.	27.50
														Class-C Telephony	1500	-100	400		148	6.5	50	1.0		165		

Mfr. No.	Type	Cathode		Base ³ and Connections	Max. Plate Voltage	Max. Plate Current (ma.)	Triode Mu or Max. Screen Voltage	Max. D.C. Control Grid Current (ma.)	Max. Plate Dissipation (Watts)	Max. Screen Dissipation (Watts)	Interelectrode Capacitances μ fds.			Typical ⁹ Operation	Plate Volts	Control Grid Bias	Screen Volts	Suppressor Volts	Plate ⁷ Current (ma.)	D.C. ⁸ Control Grid Current (ma.)	Screen Current (ma.)	*Grid Driving Power (Approx. Watts)	Load Imped. P to P (Ohms)	Power Output (Watts) typical	Mfr.	Price
		G-F In-put	P-F Out-put								G P Feed-back															
RK-49	Beam Power Tetrode	6.3	0.9	6-pin M. 21	400	100	300	6.0	21	3.5	11.5	10.6	1.4	Class-C Telegraphy	400	-50	250		95	3.0	8.0	0.2		25	Ray.	2.10
														Class-C Telephony	300	-45	200		60	5.0	15	0.3		13		
HY-51A HY-51B	Triodes	7.5	3.5	4-pin M 6	1000	155	25	25	65	6.0	2.0		7.5	Class-C Telegraphy	1000	-75			140	20		5.0		100	Hy-tron	3.95
		Class-C Telephony	800											-67.5			100	15		3.5		55				
HY-51Z	Triode	7.5	3.5	4-pin M. 6	1000	175	85	35	65	6.0	2.0		7.5	Class-C Telegraphy	1000	-22.5			150	35		5.0		110	Hy-tron	3.95
														Class-C Telephony	850	-30			135	35		9.0		77		
RK-51	Triode	7.5	3.75	4-pin M. 6	1500	150	20	40	60	6.0	2.5		6.0	Class-B Audio	1000	-45			300				9000	285	Ray.	6.95
														Class-C Telegraphy	1500	-250			150	31		10		170		
RK-52	Triode	7.5	3.75	4-pin M. 6	1500	130	150	50	62.5		6.6	2.2	12	Class-C Telegraphy	1500	-120			130	40		7.0		135	Ray.	6.95
														Class-C Telephony	1250	-120			115	47		8.5		105		
HK-54	Triode	5.0	5.0	4-pin M. 5	3000	135	27	20	50	1.9	0.2		1.9	Class-B Audio	1250	0			300	100		7.5	10000	250	H&K	6.75
														Class-C Telegraphy	2000	-269			130	20		9.0		210		
T-55	Triode	7.5	3.0	4-pin M. 6	1500	165	20	40			4.95	1.15	3.85	Class-C Telegraphy	1500	-140			165	20		5.6		183.5	Taylor	6.00
														Class-C Telephony	1500	-200			135	20		6.75		158		
HY-60	Beam Power Tetrode	6.3H	0.5	5-pin M. 30	425	60	200	4.0	15		11	10.2	0.15	Class-C Telegraphy	425	-62.5	200		55	2.5	7.0	0.25		16	Hy-tron	2.50
														Class-C Telephony	325	-45	200		45	2.0	8.5	0.2		10		
HY-61	Beam Power Tetrode	6.3H	0.9	5-pin M. 30	600	100	300	5.0	25		11	7.0	0.2	Class-C Telegraphy	600	-50	250		100	3.0	9.0	0.22		37.5	Hy-tron	3.00
														Class-C Telephony	475	-50	225		83	2.0	9.0	0.13		24		
HY-69	Beam Power Tetrode	6.3	1.5	5-pin M. 10	600	100	300	7.5	40		7.0	6.0	0.25	Class AB ₂ P. P. Audio	600	-30	300		200		10	0.4	6660	80	Hy-tron	3.50
														Class-C Telegraphy	600	-60	250		100	4.0	12.5	0.25		42		
														Class-C Telephony	600	-60	225		100	4.0	10	0.25		36		
														Class AB ₂ P. P. Audio	600	-35	300		120		29	0.7	4500	97		

75-T	Triode	5	6.5	4-pin M.	3000	250	10	30	75		2.2	0.3	2.3	Class-C Telephony	200G	-400			225	30				375	Eimac	9.00
														Class-C Telephony	2000	-400			200	30			300			
TW-75	Triode	7.5	4.15	4-pin M.	2000	175	20	60	75		3.35	0.7	1.5	Class-C Telephony	2000	-175			150	37		12.7	225	Taylor	8.00	
														Class-C Telephony	2000	-260			125	32		13.2	198			
100-TH	Triode	5.0	6.5	4-pin M. 5	3000	225	30	50	100		2.2	0.3	2.0	Class-C Telephony	3000	-210			125	50		30	300	Eimac 14	13.50	
														Class-B Audio ¹⁰	3000							30000	500			
100-TL	Triode	5.0	6.5	4-pin M. 5	3000	225	12	35	100		2.0	4.0	2.3	Class-C Telephony	3000	-600			135	30		40	300	Eimac	13.50	
														Class-B Audio ¹⁰	3000							30000	465			
HF-100	Triode	10	2.0	4-pin M. 5	1750	150	23	30	75		3.5	1.4	4.5	Class-C Telephony	1500	-200			150	18		6.0	170	Amp.	13.50	
														Class-C Telephony	1250	-250			110	21		8.0	105			
RK-100	Gas Triode	6.3H	0.9	6-pin M. 21	150	250	40	100.0	15		23	3.0	19	Class-B Audio	1750	-62			270			9.0	16000	350	Ray.	7.00
														Class-C R.F. Amp.	110				185	40		2.1	12			
TF-100	Triode	10	2.0	4-pin M. 5	1750	150	23	30	75		3.5	1.4	4.5	Class-A Audio	110	-1.6			65 ¹¹	8.5			4.2	Taylor	12.50	
														Class-A P.P. Audio	110	-1.6			130 ¹¹	17		2000	9			
ZB-120	Triode	10	2.0	4-pin Giant 12	1500	160	High	40	75		5.3	3.2	5.2	Class-C Telephony	1500	-200			150	18		6.0	170	Amp.		
														Class-C Telephony	1250	-250			110	21		8.0	105			
T-125	Triode	10	4.5	4-pin Giant 13	2500	250	25	70	125		6.3	1.3	6.0	Class-B Audio	1750	-62			270			9.0	16000	350	Taylor	13.50
														Class-C Telephony	1250	-135			160	23		5.5	145			
125-M	Beam Tetrode	5	6.5	5-pin Giant	3000	225		30	125		13	3.7	0.1	Class-C Telephony	1000	-150			120	21		5.0	95	Eimac	28.50	
														Class-C Telephony	1250	0			300			4.0	9000			245
TW-150	Triode	10	4.1	4-pin 50-Watt 13	3000	200	35	60	150		3.9	0.8	2.0	Class-C Telephony	2500	-200			250	35		12.5	500	Taylor	15.00	
														Class-C Telephony	2000	-165			250	35		12	375			
152-TL	Triode	5 or 10	13 or 6.5	Special	3000	500	10	75	150		5	0.75	5	Class-C Telephony	3000	-170			200	45		17	470	Eimac	20.00	
														Class-C Telephony	3000	-260			165	40		17	400			
														Two parallel connected 7 5-T's in one envelope												

Mfr. No.	Type	Cathode		Base ³ and Connections	Max. Plate Voltage	Max. Plate Current (ma.)	Triode Mu or Max. Screen Voltage	Max. D.C. Control Grid Current (ma.)	Max. Plate Dissipation (Watts)	Max. Screen Dissipation (Watts)	Interelectrode Capacitances $\mu\mu$ fds.			Typical ⁹ Operation	Plate Volts	Control Grid Bias	Screen Volts	Suppressor Volts	Plate ⁷ Current (ma.)	D.C. ⁸ Control Grid Current (ma.)	Screen Current (ma.)	*Grid Driving Power (Approx. Watts)	Load Imped. P to P (Ohms)	Power Output (Watts) typical	Mfr.	Price
		G-F In-put	P-F Out-put								G-P Feed-back	Volts ²	Amps.													
HF-200	Triode	10	3.4	4-pin Giant 13	2500	200	18	50	150		5.2	1.2	5.8	Class-C Telegraphy	2500	-300			200	18		8.0		380	Amp.	24.50
														Class-C Telephony	2000	-350			160	20		9.0		250		
														Class-B Audio	2500	-130			360			8.0	16000	600		
T-200	Triode	10	5.75	4-pin Giant 13	2500	350	17	60	200		9.5	1.6	7.9	Class-C Telegraphy	2500	-265			300	48		20		590	Taylor	21.50
														Class-C Telephony	2000	-220			250	41		15		390		
203-A	Triode	10	3.25	4-pin Giant 12	1250	150	25	60	100		6.5	5.5	14.5	Class-C Telegraphy	1250	-125			150	25		7.0		130	RCA	10.00
														Class-C Telephony	1000	-135			150	50		14		100		
														Class-B Audio	1250	-45			320			11	9000	260		
T-203A	Triode	10	3.25	4-pin Giant 12	1250	175	25	60	100		8.0	7.0	14	Class-C Telegraphy	1250	-125			150	25		7.0		130	Taylor	10.00
														Class-C Telephony	1000	-135			150	50		14		100		
														Class-B Audio	1250	-45			320			11	9000	260		
HD-203A	Triode	10	4.0	4-pin Giant 29	1750	250	25	60	150					Class-C R.F. Amp.	1750				250	60					Taylor	14.50
														Class-B Audio	1750	-67.5			365				10,000	400		
203-Z	Triode	10	3.25	4-pin Giant 29	1250	175	85		65					Class-B Audio	1250	-4.5			350		6.75	8000	300	Taylor	8.00	
204-A	Triode	11	3.85	Special 16	3000	275	23	80	250		12.5	2.3	15	Class-C Telegraphy	2500	-200			250	30		15		450	Amp. RCA Taylor	95.00 85.00 60.00
														Class-C Telephony	2000	-250			250	35		20		350		
														Class-B Audio	2000	-60			500			20	8800	600		
211	Triode	10	3.25	4-pin Giant 12	1250	175	12	50	100		6.0	5.5	14.5	Class-C Telegraphy	1250	-225			150	18		7.0		130	RCA W.E.	10.00
														Class-C Telephony	1000	-260			150	35		14		100		
														Class-B Audio	1250	-100			320			8.0		260		
T-211	Triode	10	3.25	4-pin Giant 12	1250	175	12	50	100		7.0	6.0	14	Class-C Telegraphy	1250	-200			150	30		11		125	Taylor	10.00
														Class-C Telephony	1000	-175			150	30		10		100		
														Class-B Audio	1250	-80			300			25	8000	200		
211-C	Triode	10	3.25	4-pin Giant 12	1250	210	12	50	125		5.5	3.5	9.0	Class-C Telegraphy	1250	-250			200	10		3.5		170	Amp.	17.50
														Class-C Telephony	1250	-300			166	8.0		3.5		148		
														Class-B Audio	1250	-90			400			4.5	6700	320		

T-211-C	Triode	10	3.25	4-pin Giant 12	1250	175	12.5	60	100		6.0	6.5	9.0	Class-C Telephony	1250				125	60				100	Taylor	12.50
														Class-C Telephony	1000	-160					150	50				
WE-211C	Triode	10	3.25	4-pin Giant 12	1250	175	12	60	100		6.0	5.5	14.5	Class-C Telephony	1250	-215			165	20		7.3		150	W.E.	
														Class-C Telephony	1000	-260					150	35		14		
T-211-D	Triode	10	3.25	4-pin Giant 12	1250	175	12	50	100		7.0	6.0	14	Class-C Telephony	1250	-200			150	30		11		125	Taylor	10.00
														Class-C Telephony	1000	-175					150	30		10		
211-H	Triode	10	3.25	4-pin Giant 29	1500	210	12.5	50	125		5.5	1.9	7.2	Class-B Audio	1250	-80			300			25	8000	200	Amp.	17.50
														Class-C Telephony	1500	-300				200	10		4.0			
WE-212E	Triode	14	6.0	4-pin W. E. 18	3000	350	16	75	275		14.9	8.6	18.8	Class-C Telephony	1250	-300			166	8.0		3.5		148	W.E.	
														Class-C Telephony	2000	-250				300	60		25			
217-A	Half-Wave Hi-Vacuum Rectifier	10	3.25	4-pin Giant 26	3500 Inverse Peak	600 Peak								Class-B Audio	1500	-110			400			5.0	8200	400	RCA	20.00
														Half-Wave Rectifier	3500	In- verse Peak				200	average					
217-C	Half-Wave Hi-Vacuum Rectifier	10	3.25	4-pin Giant 14	7500 Inverse Peak	600 Peak								Class-B Audio	1500	-75			600			50	5900	500	RCA	20.00
														Half-Wave Rectifier	7500	In- verse Peak				150	average					
WE-242A	Triode	10	3.25	4-pin Giant 12	1250	150	12.5	50			6.5	4.0	13	Class-C Telephony	1250	-200			150	30		11		125	W.E.	
														Class-C Telephony	1000	-175					150	30		10		
T-249-B	Half-Wave Mercury Vapor Rectifier	2.5	7.5	4-pin M. 1	10000 Peak Inverse	1500 Peak								Class-B Audio	1250	-80			300			25	8000	200	Taylor	5.00
														In Single-Phase Full-Wave Rectifier	3530	R.M. S. In- put				750	Out- put Mils.					
250-TH	Triode	5.0	10.5	4-pin Giant 13	3000	350	32	100	250		3.5	0.3	3.3	Class-C Telephony	3000	-210			330	75		99		750	Eimac 14	24.50
														Class-C Telephony	3000	-210					330	75		99		
250-TL	Triode	5.0	10.5	4-pin Giant 13	3000	350	13	50	250		3.0	0.5	3.5	Class-B Audio ¹⁰	1250								3280	540	Eimac	24.50
														Class-C Telephony	3000	-600				330	45		99			
														Class-C Telephony	3000	-600			330	45		99		750		
														Class-B Audio ¹⁰	1250								3280	540		

Mfr. No.	Type	Cathode		Base ³ and Connections	Max. Plate Voltage	Max. Plate Current (ma.)	Triode Mu or Max. Screen Voltage	Max. D.C. Control Grid Current (ma.)	Max. Plate Dissipation (Watts)	Max. Screen Dissipation (Watts)	Interelectrode Capacitances μ fs.			Typical ⁹ Operation	Plate Volts	Control Grid Bias	Screen Volts	Suppressor Volts	Plate ⁷ Current (ma.)	D.C. ⁸ Control Grid Current (ma.)	Screen Current (ma.)	Grid Driving Power (Approx. Watts)	Load Imped. P to P (Ohms)	Power Output (Watts) typical	Mfr.	Price
		G-F In-put	P-F Out-put								G-P Feed-back															
HK-254	Triode	5.0	7.5	4-pin Giant 13	4000	200	25	40	100		3.3	1.1	3.4	Class-C R.F. Amp.	3000	-251			167	40		19		400	H.&K.	12.50
														R.F. Doubler	2000	-600			125	40		33		150		
														Class-B Audio	3000	-100			245			14	30000	550		
WE-254B	Tetrode	7.5	3.25	4-pin M. 9	750	75	150	25	25	4.0	11.2	5.4	0.85	Class-C R.F. Amp.	750	-125	150		75					37.5	W.E.	
HK-257	Beam Power Pentode	5.0	7.5	7-pin Giant Bayonet 25	3000	150	500	25	75		13.8	6.7	0.04	Class-C Telegraphy	2000	-200	500	+60	150	6.0	11	1.4		230	H.&K.	22.50
														Class-C Telephony	1800	-130	400	+60	135	8.0	11	1.7		178		
														Sup.Mod. Telephony	2000	-130	500	-300	55	3.0	27	0.4		35		
WE-270A	Triode	10	9.75	Special 16	3000	375	16	75	350		18	2.0	21	Class-C Telegraphy	3000	-375			350	70		37		700	W.E.	
														Class-C Telephony	2250	-300			300	70		32		450		
														Class-B Audio	2000	-105			750			75	6000	850		
WE-282A	Tetrode	10	3.0	4-pin Giant 9	1600	100	150	50	70	5.0	12.2	6.8	0.2	Class-C R.F. Amp.	1000	-150	150		100					67	W.E.	
HF-300	Triode	11	4.0	4-pin Giant 13	3000	275	23	60	200		6.0	1.4	6.5	Class-C Telegraphy	2000	-200			275	36		13		410	Amp.	50.00
														Class-C Telephony	2000	-300			250	36		17		385		
														Class-B Audio	2000	-72			480			14	9600	650		
WE-300A	Triode	5.0	1.2	4-pin M. 3	450	100	3.8		40		9.0	4.3	15	Class-A Audio	450	-97			80					14.6	W.E.	10.10
														Class-A P.P. Audio	450				140				25			
														Class-C R.F. Amp.	1250	-225			100				85			
WE-304B	Triode	7.5	3.25	4-pin M. 5	1250	100	11	25	50		2.0	0.7	2.5	Class-C R.F. Amp.	1250	-110			100					85	W.E.	12.50
														Class-B Audio	1250	-110			100			10	14000	140		
304-TL	Triode	5 or 10	26 or 13	Special	3000	1000		150	300		10	1.5	10	Four parallel connected 75T's in one envelope											Eimac	65.00
WE305A ¹	Tetrode	10	3.1	4-pin M.	1000	125	200	40	60	6.0	10.5	5.4	0.14	Class-C R.F. Amp.	1000	-270	200		125					85	W.E.	
WE-307A	Pentode	5.5	1.0	5-pin M. 10	500	60	250	7.0	15	6.0	15	12	0.55	Class-C Telegraphy	500	-35	250	0	60	1.4	13			20	W.E.	
														Sup.-Mod. Telephony	500	-35	200	-50	40	1.5	20		6.0			
WE316A ¹	Triode	2.0	3.65	No base	450	80		12	30		1.2	0.8	1.6	Class-C Telegraphy	450	Adjusted for Tube			80					7.5 at 500 Mc.	W.E.	10.50

HK-354	Triode	5.0	10	4-pin Giant 29	4000	300	14	50	150		9.0	0.4	4.0	Class-C Telephony	4000	-690			245	50		48		830	H.& K.	24.50
														Class-C Telephony	3000	-550			210	50		35		525		
HK354C ¹	Triode	5.0	10	4-pin Giant 13	4000	300	14	50	150		4.5	1.1	3.8	Class-B Audio	2500	-165			350			20	15000	577	H.& K.	
														Class-C Telephony	4000	-690			245	50		48		830		
HK-354D	Triode	5.0	10	4-pin Giant 13	3500	300	22	55	150		4.5	1.1	3.8	Class-C Telephony	3000	-550			210	50		35		525	H.& K.	
														Class-B Audio	2500	-165			350			20	15000	577		
HK-354E	Triode	5.0	10	4-pin Giant 13	3500	300	35	60	150		4.5	1.1	3.8	Class-C R.F. Amp.	3500	-490			240	50		38		690	H.& K.	
														Class-B Audio	2500	-112			290			20	20000	519		
HK-354F	Triode	5.0	10	4-pin Giant 13	3500	390	50	75	150		4.5	1.1	3.8	Class-C R.F. Amp.	3500	-448			240	60		45		690	H.& K.	
														Class-B Audio	2000	-37.5			372			20	11000	472		
450-TH	Triode	7.5	12	4-pin Giant 13	6000	500	32	125	450		4.0	0.6	4.0	Class-C R.F. Amp.	3500	-368			250	75		50		720	H.& K.	
														Class-B Audio	2500	-35			300			20	20000	550		
450-TL	Triode	7.5	12	4-pin Giant 13	6000	500	16	75	450		4.0	0.6	4.0	Class-C Telephony	4000	-400			500	70		100		1550	Eimac	75.00
														Class-C Telephony	4000	-400			400	70		100		1250		
HK-654	Triode	7.5	15	4-pin Giant 13	4000	600	25	100	300		6.2	1.5	5.5	Class-C Telephony	4000	-700			500	70		100		1550	Eimac	75.00
														Class-C Telephony	4000	-700			400	70		100		1250		
800	Triode	7.5	3.25	4-pin M. 5	1250	80	15		35		2.75	2.75	2.5	Class-C Telephony	2500	-406			500	75		59		950	H.& K.	
														Class-C Telephony	3000	-390			400	95		60		945		
801 801-A	Triode	7.5	1.25	4-pin M. 3	600	70	8		15		4.5	1.5	6.0	Class-B Audio	1500	-45			643			50		675	RCA	10.00
														Class-C Telephony	1250	-175			70	15		4.0		65		
802 ^a	Pentode	6.3H	0.9	7-pin M. 7	600	60	250	7.5	13		12	8.5	0.15	Class-C Telephony	1000	-200			70	15		4.0		50	RCA	3.45
														Class-B Audio	1250	-70			130			3.4		106		
803	Pentode	10	5.0	5-pin Giant 11	2000	175	600	50	125		17.5	29	0.15	Class-C Telephony	600	-150			65	15		4.0		25	RCA	28.50
														Class-C Telephony	500	-190			55	15		4.5		18		
802 ^a	Pentode	6.3H	0.9	7-pin M. 7	600	60	250	7.5	13		12	8.5	0.15	Class-B Audio	600	-75			130			3.0		45	RCA	3.50
														Class-C Telephony	500	-100	200	0	45	6.0	22	0.9		14		
803	Pentode	10	5.0	5-pin Giant 11	2000	175	600	50	125		17.5	29	0.15	Class-C Telephony	400	-40	200	+45	35	1.5	17	0.1		8	RCA	28.50
														Sup.-Mod. Telephony	500	-45	200	-45	22	4.5	28	0.5		3.5		
803	Pentode	10	5.0	5-pin Giant 11	2000	175	600	50	125		17.5	29	0.15	Class-C Telephony	2000	-90	500	+40	160	12	45	2.0		210	RCA	28.50
														Class-C Telephony	1600	-80	500	+100	150	20	55	4.0		155		
														Sup.-Mod. Telephony	1500	-100	310	-90	100	20	70	3.5		50		

Mfr. No.	Type	Cathode		Base ³ and Connections	Max. Plate Voltage	Max. Plate Current (ma.)	Triode Mu or Max. Screen Voltage	Max. D.C. Control Grid Current (ma.)	Max. Plate Dissipation (Watts)	Max Screen Dissipation (Watts)	Interelectrode Capacitances $\mu\text{fd.}$			Typical ⁹ Operation	Plate Volts	Control Grid Bias	Screen Volts	Suppressor Volts	Plate ⁷ Current (ma.)	D.C. ⁸ Control Grid Current (ma.)	Screen Current (ma.)	Grid Driving Power (Approx. Watts)	Load Imped. P to P (Ohms)	Power Output (Watts) typical	Mfr.	Price
		Volts ²	Amps.								G-F In-put	P-F Out-put	G-P Feed-back													
804 ⁶	Pentode	10	5.0	5-pin M. 11	1500	100	300	15	50		16	14.5	0.01	Class-C Telegraphy	1250	-100	300	+45	92	7.0	27	0.95		80	RCA	15.00
														Class-C Telephony	1000	-90	220	+50	75	6.0	21	0.65		50		
														Sup.-Mod. Telegraphy	1250	-100	300	-50	48	7.0	35.5	0.85		21		
805	Triode	10	3.25	4-pin Giant 29	1500	210	45	60	125		8.5	10.5	6.5	Class-C Telegraphy	1500	-105			200	40		8.5		215	RCA	13.50
														Class-C Telephony	1250	-160			160	60		16		140		
														Class-B Audio	1500	-16			400			7.0	8200	370		
T-805	Triode	10	3.2	4-pin Giant 29	1750	210	45	70	125		8.4	1.3	7.7	Class-C Telegraphy	1750	-90			200	44		9.2		270	Taylor	13.50
														Class-C Telephony	1500	-140			175	40		10.5		208		
														Class-B Audio	1750	-22.5			420			10	9350	320		
806 ⁶	Triode	5.0	10	4-pin Giant 29	3300	300	12.6	50	225		6.1	1.1	3.4	Class-C Telegraphy	3000	-600			195	25		20		450	RCA	22.00
														Class-C Telephony	2500	-600			195	40		32		390		
														Class-B Audio	2000	-150			390			14		500		
807 ⁶	Beam Power Tetrode	6.3	0.9	5-pin M. 30	750	100	300	5.0	30		11	7.0	0.2	Class-C Telegraphy	600	-50	250		100	3.0	9.0	0.22		37.5	RCA	3.50
														Class-C Telephony	475	-50	225		83	2.0	9.0	0.13		24		
														Class AB ² Audio	600	-30	300		200		10	0.4		80		
808	Triode	7.5	4.0	4-pin M. 5	1500	150	47	35	50		5.3	0.15	2.8	Class-C Telegraphy	1500	-200			125	30		9.5		140	RCA	7.75
														Class-C Telephony	1250	-225			100	32		10.5		105		
														Class-B Audio	1500	-25			190			4.8	18300	185		
809 ⁶	Triode	6.3	2.5	4-pin M. 6	1000	100	50	35	30		5.7	0.9	6.7	Class-C Telegraphy	750	-60			100	20		2.5		55	RCA	2.50
														Class-C Telephony	600	-160			83	32		7.2		38		
														Class-B Audio	750	-5			200			2.4	8400	100		
810 ⁶	Triode	10	4.5	4-pin Giant 29	2250	275	36	70	150		8.7	12	4.8	Class-C Telegraphy	2250	-160			275	40		12		475	RCA	13.50
														Class-C Telephony	1800	-200			250	50		17		335		
														Class-B Audio	2250	-60			450			13	11600	725		
811 ⁶	Triode	6.3	4.0	4-pin M. 6	1500	150	160	50	55		5.5	0.6	5.5	Class-C Telegraphy	1500	-113			150	35		8.0		170	RCA	3.50
														Class-C Telephony	1250	-125			125	50		11		120		
														Class-B Audio	1500	-9.0			200			4.2	18000	225		

812 ^e	Triode	6.3	4.0	4-pin M. 6	1500	150	29	35	55	5.3	0.8	5.3	Class-C Telephony	1500	-175			150	25		6.5		170	RCA	3.50
													Class-C Telephony	1250	-125			125	25		6.0		120		
													Class-B Audio	1500	-46			200			4.7		225		
813	Beam Power Tetrode	10	5.0	7-pin L. 28	2000	180	400	25	100	16.3	14	0.2	Class-C Telephony	2000	-90	400		180	3.0	15	0.5		260	RCA	22.00
													Class-C Telephony	1600	-130	400		150	6.0	20	1.2		175		
814 ^e	Beam Power Tetrode	10	3.25	5-pin M. 10	1500	150	300	15	65	13.5	13.5	0.1	Class-C Telephony	1500	-90	300		150	10	24	1.5		160	RCA	17.50
													Class-C Telephony	1250	-150	300		144	10	20	3.2		130		
T-814	Triode	10	4.0	4-pin Giant 29	3000	300	12	60	200	8.5	2.1	13.5	Class-C Telephony	2500	-190			300	51		17		600	Taylor	18.50
													Class-C Telephony	2000	-75			250	43		13.7		405		
													Class-B Audio	1500	-35			500			7.0	6800	525		
8151 ^e	P.P. Beam Power Tetrode	6.3 or 12.6	0.8 per Unit	Octal 27	500	150	200	10	25	13	9.5	0.15	Class-C Telephony	500	-100	200		150	10	17	0.13		56	RCA	
													Class-C Telephony	400	-100	200		150	10	15	0.16		45		
T-822	Triode	10	4.0	4-pin Giant 29	3000	300	30	60	200	8.5	2.1	13.5	Class-C Telephony	2500	-190			300	51		17		600	Taylor	18.50
													Class-C Telephony	2000	-75			250	43		13.7		405		
													Class-B Audio	1500	-35			500			7.0	6800	525		
828 ^e	Beam Power Pentode	10	3.25	5-pin M. 10	2000	180	750	15	80	13.5	14.5	0.05	Class-C Telephony	1500	-100	400	+75	180	12	28	2.2		200	RCA	17.50
													Class-C Telephony	1250	-300	400	+75	160	12	28	2.7		150		
													Class AB ¹ Audio	2000	-120	750	+60	270		60	0		385		
829 ¹	P.P. Beam Power Tetrode ^{1,2}	6.3 or 12.6	1.125 per Unit	Special 24 ^{1,5}	500	240	225	15	40	15.2	6.5	0.1	Class-C Telephony	500	-45	200		240	12	32	0.7		83	RCA	19.50
													Class-C Telephony	425	-60	200		212	11	35	0.8		63		
830-B	Triode	10	2.0	4-pin M. 6	1000	150	25	30	60	5.0	1.8	11	Class-C Telephony	1000	-110			140	30		7.0		90	RCA	10.00
													Class-C Telephony	800	-150			95	20		5.0		50		
													Class-B Audio	1000	-35			280			6.0	7600	175		
831 ¹	Triode	11	10	Special Base-less	3500	350	14.5	75	400	3.8	1.4	4	Class-C Telephony	3500	-400			275	40		30		590	RCA	
													Class-C Telephony	3000	-500			200	60		50		360		
832 ¹	P.P. Beam Power Tetrode ^{1,2}	6.3 or 12.6	0.8 per Unit	Special 24 ^{1,5}	400	90		6.0	15	7.5	3.8	0.05	Class-C Telephony	400	-60	250		90	3.0	18	0.18		22	RCA	17.00
													Class-C Telephony	325	-50	210		68	1.2	15	0.06		12		
833 ¹	Triode ^{1,3}	10	10	Special Base-less	3000	800	35	75	300	12.3	8.5	6.3	Class-C Telephony	2500	-200			475	65		25		925	RCA	85.00
													Class-C Telephony	2500	-300			335	75		30		635		
													Class-B Audio	2650	-62			520			5.0	10400	840		

Mfr. No.	Type	Cathode		Bases and Connections	Max. Plate Voltage	Max. Plate Current (ma.)	Triode Mu or Max. Screen Voltage	Max. D.C. Control Grid Current (ma.)	Max. Plate Dissipation (Watts)	Max. Screen Dissipation (Watts)	Inter-electrode Capacitances $\mu\text{fdfs.}$			Typical ⁹ Operation	Plate Volts	Control Grid Bias	Screen Volts	Suppressor Volts	Plate ⁷ Current (ma.)	D.C.* Control Grid Current (ma.)	Screen Current (ma.)	*Grid Driving Power (Approx. Watts)	Load Imped. P to P (Ohms)	Power Output (Watts) typical	Mfr.	Price
		G-F In-put	P-F Out-put								G-P Feed-back															
834 ¹	Triode	7.5	3.25	4-pin M. 5	1250	100	10.5	20	50					Class-C Telegraphy	1250	-225			90	15		4.5		75	RCA	12.50
														Class-C Telephony	1000	-310			90	17.5		6.5		58		
836	Half-Wave Hi-Vacuum Rectifier	2.5H	5.0	4-pin M. 1	5000 Inverse Peak	1000 Peak													250 average					RCA	11.50	
837	Pentode	12.6H	0.7	7-pin M. 7	500	50	200	8	12					Class-C Telegraphy	500	-75	200	+40	60	4.0	15	0.4		20	RCA	7.50
														Class-C Telephony	400	-40	140	+40	45	5.0	20	0.3		11		
838	Triode	10	3.25	4-pin Giant 12	1250	175	High	70	100					Class-C Telegraphy	1250	-90			150	30		6.0		130	RCA Taylor	11.00 11.00
														Class-C Telephony	1000	-135			150	60		16		100		
														Class-B Audio	1250	0			320			7.5	9000	260		
841	Triode	7.5	1.25	4-pin M. 3	450	60	30	20						Class-C Telegraphy	450	-34			50	15		1.8		15	RCA Ray.	3.25
														Class-C Telephony	350	-47			50	15		2.0		11		
														Class-B Audio	425	-5.0			114			3.6	7000	28		
843	Triode	2.5H	2.5	5-pin M. 4	450	40	7.7	7.5	15					Class-C Telegraphy	450	-140			30	5.0		1.0		7.5	RCA	12.50
														Class-C Telephony	350	-150			30	7.0		1.6		5.0		
844	Tetrode	2.5H	2.5	5-pin M. 8	500	30	180	5.0	15					Class-C Telegraphy	500	-125	175		25	5.0			9.0	RCA	18.00	
														Class-C Telephony	500	-100	150		20			4.0				
845	Triode	10	3.25	4-pin Giant 12	1250	120	5.3		75					Class-A Audio	1250	-209			52				24	RCA Taylor	10.00	
														Class-AB Audio	1250	-225			200			8800	105			
849	Triode	11	5.0	Special	3000	350	19	35	400					Class-C Telegraphy	2500	-250			300	20		8.0		560	RCA	120.00
														Class-C Telephony	2000	-300			300	30		14		425		
														Class-B Audio	2000	-105			650			16	6400	900		
849	Triode	11	5.0	Special	3000	350	19	125	400					Class-C Telegraphy	2500	-250			350	9.0		3.0		630	Amp.	160.00
														Class-C Telephony	2000	-300			300	10		4.0		425		
														Class-B Audio	2000	-90			680			8.0	6400	880		
852	Triode	10	3.25	4-pin M. top grid side plate	3000	150	12	40	100					Class-C Telegraphy	3000	-600			85	15		12		165	RCA	16.40
														Class-C Telephony	2000	-500			67	30		23		75		

860	Tetrode	10	3.25	4-pin M. top grid side plate	3000	150	300	40	100	7.75	7.5	0.08	Class-C Telephony	3000	-150	300		85	15		7.0		165	RCA	32.50
													Class-C Telephony	2000	-200	220		85	38	25	17		105		
861	Tetrode	11	10	Special	3500	350	500	75	400	14.5	10.5	0.1	Class-C Telephony	3500	-250	500		300	40	40	30		700	RCA	195.00
													Class-C Telephony	3000	-200	375		200	55		35		400		
865	Tetrode	7.5	2.0	4-pin M. 9	750	60		15	15	8.5	8	0.1	Class-C Telephony	750	-80	125		40	5.5		1.0		16	RCA	12.75
													Class-C Telephony	500	-120	125		40	9.0		2.5		10		
866	Half-Wave Mercury Vapor Rectifier	2.5	5.0	4-pin M. 1	7500 Inverse Peak	1000 Peak							Half-Wave Rectifier											RCA Ray. Sheldon Taylor Hytron	Av. 1.50
866-A	Half-Wave Mercury Vapor Rectifier	2.5	5.0	4-pin M. 1	10000 Inverse Peak	1000 Peak							Half-Wave Rectifier											Amp. Ray. RCA Sheldon	Av. 2.50
866 Jr.	Half-Wave Mercury Vapor Rectifier	2.5	3.0	4-pin M. 23	1750 Inverse Peak	250 Peak							Half-Wave Rectifier	1250 Max. R.M. S.										Taylor Hytron	Av. 1.00
872	Half-Wave Mercury Vapor Rectifier	5.0	10	4-pin Giant 14	7500 Inverse Peak	5000 Peak							Half-Wave Rectifier											RCA	9.00
872-A	Half-Wave Mercury Vapor Rectifier	5.0	6.75	4-pin Giant 14	10000 Inverse Peak	5000 Peak							Half-Wave Rectifier											Amp. Ray. RCA Taylor	Av. 11.00
1608	Triode	2.5	2.5	4-pin M. 3	425	95	20	25	20	8.5	3.0	9.0	Class-C Telephony	425	-200			95	25				20	RCA	4.00
													Class-C Telephony	350	-200			85	25			16			
1623	Triode	6.3	2.5	4-pin M. 6	1000	100	20	25	30	5.7	0.9	6.7	Class-C Telephony	750	-85			100	17		2.5		55	RCA	2.50
													Class-C Telephony	600	-125			83	25		5		38		
1624	Beam Power Tetrode	2.5	2.0	5-pin M. 10	600	90	300	5.0	25	11	7.5	0.25	Class-B Audio	750	-25			200			4.0	8400	100	RCA	3.50
													Class-C Telephony	600	-60	300		90	5.0	10	0.43		35		
													Class-C Telephony	500	-50	275		75	3.3	9.0	0.25		24		
1628 ¹	Triode	3.5	3.25	Special Base-less	1000	60	23	15	40	2.0	0.4	2.0	Class-AB ₂ Audio	600	←25	300		42		15	1.2	7500	72	RCA	32.00
													Class-C Telephony	1000	-65			50	15		1.7		35		
													Class-C Telephony	800	-100			40	11		1.6		22		

Transmitter Design

The amateur who is technically inclined will realize much pleasure not only in the actual construction of his transmitter but also in planning it. Receivers are designed pretty much as an integral unit, but there is an infinite combination of tubes, exciter circuits, amplifier circuits, and power supply arrangements which one may incorporate in a "200-watt" transmitter. For this reason few complete transmitter circuit diagrams are shown in this book.

If a tube requires 25 watts r.f. driving power for a certain application, it is obvious that it makes little difference just what exciter circuit is used so long as it puts out 25 watts on the desired bands. Because of its characteristics one exciter may be preferred by one amateur, another exciter by another amateur.

It is fortunate that there is this flexibility with regard to transmitter design, because it makes it easy for an amateur to start out with a low power transmitter and then add to it from time to time, perhaps later going on phone. It also permits one a certain degree of "custom tailoring" of his transmitter to suit his particular requirements.

In several following chapters of this book are described inexpensive yet versatile and efficient exciters, power amplifiers, speech amplifiers, modulators, and power supplies. It is the purpose of this chapter to give the reader sufficient general design information to be able to work out various combinations of these independent yet complementary units and to evolve one which is well suited to his particular needs and pocketbook. However, before proceeding further one should be thoroughly familiar with the chapter on fundamental transmitter theory, chapter 7.

Exciters and Transmitters. A five-watt crystal oscillator may be accurately referred to as a transmitter *when it is used to feed an antenna*. On the other hand a multi-tube r.f. unit winding up in a 150-watt power amplifier may be properly termed an exciter *when it is used to drive a higher power amplifier*. Thus

we see that any r.f. unit, even a simple oscillator, may be either an exciter or a transmitter depending upon how it is used.

The requirements for a low power (15 to 75 watt) transmitter are practically the same as for an exciter of the same output: The overall efficiency should be good, the unit should cover all the desired bands with a minimum of coil changing and retuning, and both initial cost and upkeep should be low in proportion to the power output.

Virtually all medium and high power amplifiers (200-800 watts output) are very much the same except for the particular make and power rating of components used. Perhaps half the amateurs making use of high power use cross-neutralized push-pull final amplifiers which differ only in the method of obtaining bias and method of antenna coupling.

For this reason, several low power r.f. units and several medium and high power amplifiers are described, and the reader is permitted to use his own ingenuity in working out the combination which appears to fit his requirements. If one is designing a complete transmitter, to which no additions are to be made, it is probably best to decide first upon the final amplifier and then work backwards from there, the driving requirements of the particular tubes used determining the exciter. On the other hand many amateurs do not have the wherewithal to start right off with high power, and therefore very likely to decide upon the highest powered r.f. unit they can afford and let it go at that. In the latter event the unit may have slightly more output than required to drive an amplifier whose addition is contemplated at a later date. However, a reserve of excitation power is not a liability and does not represent poor economy unless carried to extremes. Hence, one who cannot afford to start off with high power can pick out the highest powered exciter he can afford and use it as a transmitter, without worrying too much about its adaptability for use with a particular power amplifier later on. A 75-watt r.f. unit

is slightly larger than necessary for driving a pair of 35T's, HK54's, 808's, T40's, HY51's, etc., but there is no reason why one should not use such a combination. *Not enough* excitation is a much more serious condition than an overabundance of excitation, there being no objection to the latter except from an economic standpoint.

Choosing the Tubes. Low power exciters invariably use receiving tubes or "modified" receiving tubes for the sake of economy. Large scale production brings the cost of 42's, 6L6's etc., down to a price that would be impossible were they designed for and purchased only by amateurs. Some tubes, like the T21 and 807, resemble standard receiving tubes in one or more respects and while costing more than a standard receiving tube equivalent (6L6G in this case) are still obtainable at a price below that which would be necessary were they not outgrowths of receiving tubes.

The tubes in the high power amplifier and in the class B modulator (if used) should be chosen with care. While in general there is little to choose between tubes by reliable manufacturers, some are better adapted than others for certain applications. Also, the more recently released tubes of a particular manufacturer are usually better and less expensive than older tubes of the same general type.

Some of the older type tubes such as the venerable 203-A have been improved upon and their price periodically lowered until they compare favorably with recently released tubes; for certain applications they are a good buy and are highly recommended. Other tubes of this vintage, such as the 865, have been superseded by less expensive tubes giving better performance, and are manufactured primarily for replacement purposes.

Driving Power. It is always advisable to have a slight reserve of driving power in order to be on the safe side. Therefore the potential output of an exciter on the band upon which its output is least (usually the highest frequency band) should be slightly greater than the excitation requirements of the following stage as determined from the manufacturer's data.

Plate modulated class C amplifiers require the most excitation, the tube requiring full maximum rated grid current and at least $2\frac{1}{2}$ times cutoff bias if full plate input is run.

C.w. and buffer amplifiers should preferably be run at full rated grid current (though they *may* run with as much as 50% less) and at $1\frac{1}{2}$ times cutoff or greater bias. Thus an unmodulated final amplifier or buffer can be used with considerably less excitation than

a plate modulated stage of the same power.

Cathode modulated amplifiers require about the same amount of excitation power as c.w. amplifiers, the bias being greater but the grid current much less. Cathode modulated stages are commonly run at from $2\frac{1}{2}$ to 4 times cutoff bias at approximately an eighth the grid current recommended for plate modulation.

High efficiency grid modulation requires still less excitation. The bias is from 2 to 4 times cutoff but the grid current is very low, seldom greater than a few ma. even for high power stages. The power dissipated in the grid swamping resistor, a necessary adjunct to a correctly operated grid modulated stage, keeps the excitation requirements from being less than they are.

The excitation required for a typical 200-watt output amplifier will run about as follows: Plate modulated, 35 watts; c.w. or buffer, 20 watts; cathode modulated, 15 watts; grid modulated, 8 watts. The whole problem of excitation requirements depends so much upon operating conditions that one had best refer to the manufacturers data sheets or to chapter 10 of this Handbook.

The question of calculating excitation requirements for a doubler stage was not covered in the foregoing discussion, because the excitation power required depends to such a great degree upon the doubler efficiency desired. For high efficiency doublers, the bias should be at least 5 times cutoff and the grid current about half the maximum rated value for the tube. Thus it is seen that for good doubler efficiency a tube requires as much excitation power as does a plate modulated stage of the same power output rating.

Also to be taken into consideration when tentatively planning a transmitter are such things as the limiting factor in tube design. For instance in a grid modulated transmitter the output is always limited by the plate dissipation, while for plate modulated phone work either the plate voltage or plate current rating is exceeded first. Thus we see that for grid modulation a tube with high plate dissipation is of prime importance, while for plate modulated operation the matter of filament emission and insulation are of greatest importance.

Another thing to be taken into consideration, especially when designing a phone transmitter, is the item of filament voltage. Obviously a saving can be effected if both r.f. amplifier tubes and modulator tubes can be run from the same filament winding.

Care should be taken to make sure that the tubes chosen are capable of efficient and safe operation on the highest frequency used.

Design Considerations

Transmitter Wiring. At the higher frequencies, solid enamelled copper wire is most efficient for r.f. leads. Tinned or stranded wire will show greater losses at these frequencies. Tank coil and tank condenser leads should be of heavier wire than other r.f. leads, though there is little point in using wire heavier than is used for the tank coil itself.

All grounds and by-passes in an r.f. stage should be made to a common point, and the grounding points for several stages bonded together with heavy wire.

Best type flexible leads to terminals coming out envelope of tubes is thin copper strip, cut from thin sheet copper. Heavy, rigid leads to these terminals may crack the envelope glass when a tube heats or cools.

Wires carrying only a.f. or d.c. should be chosen with the voltage and current in mind. Some of the low-voltage-filament type transmitting tubes draw heavy current, and heavy wire must be used to avoid voltage drop. The voltage is low, and hence not much insulation is required. Filament and heater leads are usually twisted together. An initial check should be made on the filament voltage of all tubes of 25 watts or more plate dissipation rating. This voltage should be measured right at the tube sockets. If it is low, the filament transformer voltage should be raised. If this is impossible, heavier or paralleled wires should be used for filament leads, cutting down their length if possible.

Spark plug type high tension ignition cable makes the best wire for high voltage leads. This cable will safely withstand the highest voltages encountered in an amateur transmitter. If this cable is used, the high voltage leads may be cabled right in with filament and other low voltage leads. For high voltage leads in low power exciters where the plate voltage is not over 450 volts, ordinary radio hookup wire of good quality will serve the purpose. Twisted lamp cord, in good condition with insulation intact, can be used for power supply leads between low power exciter units and power supplies where the voltage does not exceed 400 volts.

No r.f. leads should be cabled; in fact it is better to use enamelled or bare copper wire for r.f. leads and rely upon spacing for insulation. All r.f. joints should be soldered, and the joint should be a good mechanical junction before soldering is applied. Soldering technique is covered in chapter 23.

Coil Placement. While metal shield baffles are effective in suppressing stray capacity coupling between circuits, they are not always

effective in suppressing inductive coupling. To eliminate all inductive coupling between two coils in inductive relation to each other, each coil should be completely enclosed in an individual shield can. This is not always convenient; so more often the inductive coupling is minimized by orienting the coils for maximum suppression of coupling, and shield baffles used only to prevent stray capacity coupling between stages.

For best Q a coil should be in the form of a solenoid approximately as long as its diameter. For minimum interstage coupling, coils should be made as small physically as is practicable. The coils should then be placed so that adjoining coils are oriented for minimum mutual coupling. To determine if this condition exists, apply the following test: The axis of one of the two coils must lie in the plane formed by the center turn of the other coil. If this condition is not met there is bound to be appreciable coupling unless the unshielded coils are very small in diameter or are spaced considerable distance from each other.

Variable Condensers. The question of optimum C/L ratio and condenser plate spacing is covered in the chapter on transmitter theory. For all-band operation of a high power stage it is recommended that a condenser just large enough for 40-meter c.w. operation be chosen (this will have sufficient capacity for phone operation on all higher frequency bands). Then use fixed padding condensers for operation on 80 and 160 meters. Such padding condensers are available in air, gas-filled, and vacuum types.

Specially designed variable condensers are recommended for u.h.f. work; ordinary condensers often have "loops" in the metal frame which resonate near the operating frequency.

Insulation. On frequencies above 7 Mc., ceramic, polystyrene, or mycalex insulation is to be recommended, though hard rubber will do almost as well. Cold flow must be considered when using polystyrene (vietron, Amphénol 912, etc.) or hard rubber. Bakelite has low losses on the lower frequencies but should never be used in the field of high-frequency tank circuits.

Lucite, which is available in rods, sheets, or tubing, is excellent for use at all radio frequencies where the r.f. voltages are not especially high. It is very easy to work with ordinary tools and is not expensive.

The most important things to keep in mind regarding insulation is that the best insulation is none at all. If it is necessary to reinforce air-wound coils to keep turns from vibrating or touching, use strips of lucite or

polystyrene cemented in place with Amphenol 912 coil dope. This will result in lower losses than the commonly used celluloid ribs and duco cement.

Metering. The ideal transmitter would have an individual meter in every circuit requiring measurement. However, for the sake of economy many of us are forced to measure filament and plate voltages by means of a test set or universal meter during the initial try-out of the transmitter and then assume that these voltages will be maintained. Further economies can be effected by doubling up on meters when measuring current in various circuits in which the current is variable and is an index of transmitter tuning.

By a system of plugs and jacks, or a selector switch, one or two milliammeters can be used to make all the measurements necessary to tune up a transmitter properly. However, it often is of considerable advantage to be able to observe the current of several circuits or stages simultaneously. Thus the problem boils down to: buy as many meters as you can afford or as many as the total transmitter investment justifies, purchasing the most necessary meters first. Obviously one would not be justified in buying \$100 worth of meters for a transmitter containing other parts totaling \$75. On the other hand the purchase of a filament voltmeter to keep careful tab on the filament voltage of a pair of 250 watt tubes is a good investment.

Probably the most popular arrangement calls for meter switching or meter jacks in the low power stages and individual meters in the last stage. Ordinarily, r.f. meters are not used except in certain antenna coupling circuits. Where line voltage does not fluctuate appreciably, one can get by very nicely with just d.c. milliammeters, plate current meters in the low power stages and a grid and a plate meter in the final stage.

Where it is impossible to keep meter or meter leads well away from high r.f. voltage or heavy r.f. current, d.c. meters should be by-passed with small .004 or larger condensers directly at the meter terminals. The condenser is placed across the terminals, not from one terminal to ground. Such condensers are a wise precaution in all cases, because even though meter and meter leads are kept away from r.f. components, the meter may be subjected to considerable r.f. because of an r.f. choke not doing a 100% job of blocking r.f. from the meter.

Most meters now come with bakelite cases. If the "zero adjuster" screw is well insulated, such meters can be placed in positive high voltage leads where the voltage does not exceed

1000 volts. When the voltage is higher than 1000 volts, the meter should preferably be placed behind a protective glass. The meter should not be mounted directly on a grounded metal panel when the plate voltage exceeds 2000 volts, as the metal portions of the meter may arc through the bakelite case to the grounded metal panel, particularly when plate modulation is used.

One highly recommended method of arranging meters in a high powered rack and panel transmitter is to group all meters on a Masonite meter panel at the top of the rack, near eye level of the operator and not close to any of the tuning dials. With the Masonite meter panel, there is no danger of meters arcing to ground, and because of the position of the meters there is little likelihood of an operator accidentally coming in contact with the meters.

An alternate system is to place all meters in low voltage circuits directly on the metal panels (assuming meters of the bakelite case type) and to place the plate milliammeters in all stages having a plate voltage of more than 1000 behind the panel, where they are observed through small windows.

Meter Switching. This method can be used to advantage where the voltages on the leads which carry the current to be measured are not greater than about 500 volts to ground. 50-ohm resistors are inserted in the leads, and because the resistance of the meter is so low compared to the 50 ohm resistors, the meter can be considered as being inserted in series with the circuit when it is tapped across the resistor. Thus with a double pole selector switch having sufficient positions one can use a single meter to measure the current in several circuits.

The resistor should be made 25 ohms where the current to be measured runs over 200 ma., and the resistor increased to 200 ohms when the current to be measured is less than 15 ma. It is necessary to minimize the resistance where heavy current is present in order to avoid excessive voltage drop when the meter is not shunting the resistor. It is necessary to increase the value of resistance when the current is so low that a low range meter must be used to measure the current. Low range milliammeters begin to show appreciable resistance themselves, and their calibration will be thrown off when shunted by too low a value of resistor.

Meter switching is not practicable in high voltage circuits (over 1200 volts). For measuring plate current in high power stages, the resistor should be placed either in the B minus lead or in the filament return (center tap). Placing the meter resistor in the B

minus is not practical except when a power supply is used to feed but a single stage or when heater-type tubes or separate filament transformers are used, as otherwise the meter would indicate total current to all the stages.

Placing the meter in the filament return gives a reading of the total *space current*, which includes both grid current and plate current (and in the case of tetrodes and pentodes, screen current). This point is covered later under "Meter Jacks."

It is possible, by means of various systems of shunts, to use a single low-range meter for measuring widely different values of current in different circuits, much in the manner of the single-meter test set so popular with servicemen. For instance a 0-25 ma. meter could be used for measuring grid current in several stages and then used as a 0-250 ma. instrument when switched into the plate circuit of the final stage by the incorporation of a shunt in the latter circuit to extend the range to 250 ma. Ordinarily, however, a meter is used as a single-scale instrument with this type of switching, a 0-25 ma. meter being used only to read current in circuits carrying up to 25 ma.

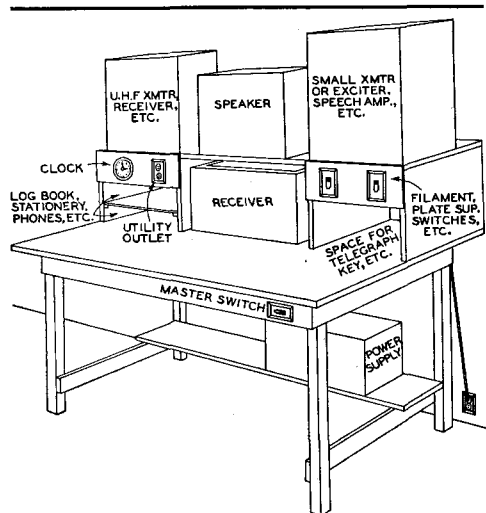

Figure 1.

UTILITY TYPE OPERATING TABLE.

Any amateur handy with a hammer and saw can construct a table of this type with little difficulty and at small cost. If a power supply is placed under the table as shown, it should be housed on the front and top in order to protect the operator from accidental contact with any of the components with his foot. If the equipment supported by the table is especially heavy, the two back legs of the table should be cross braced.

Meter Jacks. A popular method of using one meter to measure the current in several circuits is to incorporate jacks in the various circuits to be measured. Instead of using low values of resistors across the jacks to provide a current path when the meter is not plugged in a circuit, shorting type jacks are used so that when a meter is removed from a jack the circuit is automatically closed.

As with meter switching, meter shunts may be placed across certain of the jacks to extend the range of a milliammeter; however, it is more common practice to have a low range meter and a high range meter and plug the appropriate meter in each circuit.

Meter jacks should not be used except where one side of the circuit can be grounded. This permits one to measure grid current, and, indirectly, plate current. The plate current is ascertained by measuring the current flowing in the filament return and subtracting the grid current (including screen current if the tube has a screen).

In connecting up meter jacks it is important that they be wired so that the meters read in the correct direction. This can be determined by figuring just which way the current is flowing in each circuit. If this were not done, the leads to the meter would have to be reversed when reading grid current after reading cathode current.

It necessitates insulating the frame of either the grid current jack or the cathode current jack from a grounded metal panel if such a panel is used. It is common practice to ground the frame of the cathode circuit jack and insulate the frame of the grid current jack, as this affords maximum protection to the operator.

A piece of heavily-insulated rubber covered two-wire cable can be used to connect the meter to the meter plug. If the meter is permanently mounted on the panel, the meter cord should be long enough to reach all meter jacks into which it is to be plugged. To protect low range meters, cathode current jacks in stages drawing heavy current are usually placed in such a position that it is impossible to reach the jack with the cord attached to the low-range meter.

Meter jacks should never be placed in high-voltage leads, and it is inadvisable to use them in any circuit where one side of the jack is not at ground potential. When used for measuring cathode current, the frame of the jack should always be grounded, as a defective contact in the jack or a blown meter might otherwise endanger the operator by putting high potential on the meter cord and plug.

A 50-ohm carbon resistor across the terminals of all cathode current meter jacks will not affect the calibration of the meter yet will protect the operator from possible shock in the event that the meter should blow or the cord open up or come loose on the ground side. In this case the resistor is more of a protective device than a substitute path for the current when the meter is being used in some other circuit, and little current will flow through the resistor unless the jack, cord, or meter becomes defective.

The Audio System. In constructing audio equipment, the low level stages should always be mounted on a metal chassis and the bottom of the chassis shielded. For amateur work "high fidelity" is neither necessary nor desirable, as the sideband width is increased without an increase in intelligibility. This means that high-output microphones of the "p.a." type designed particularly for speech transmission (such as the high output, diaphragm crystal) can be used, and the speech amplifier need have but moderate gain. This greatly simplifies the problem of construction, as the difficulties and chances for trouble go up rapidly as the maximum overall gain of an amplifier is increased much beyond this point. Elaborate precautions against r.f. and a.f. feedback and hum pickup must be taken when low-level high-fidelity microphones of the broadcast type are used, but with the type recommended only a few simple precautions need be taken.

If a microphone which requires an input transformer is used, such as the dynamic type, care must be taken in the orientation of the input transformer in order to avoid hum pickup, especially if it is within a few feet of power transformers. Heavily-shielded input transformers of the "hum bucking" type are recommended for input transformers.

It is a good idea to design the amplifier for about 150 or 200 cycle cutoff, as this not only increases the intelligibility and effective modulation power (as explained in chapter 14) but also minimizes hum troubles. This means that one can use inexpensive audio components and also that one need not isolate the d.c. from the primary of a.f. transformers, because we don't want extreme bass response anyhow. *Low harmonic distortion* is of more importance in getting a good sounding amateur signal than is wide-range frequency response.

The foregoing is more appropriately and extensively covered in the chapter on radiotelephony theory, but is mentioned here because it is so much tied in with transmitter design: how we lay out or plan the speech system of a transmitter depends upon just what

features are to be incorporated and what requirements must be met. Before planning a speech amplifier or modulator one should read both the chapter on radiotelephony theory and the chapter on workshop practice.

Mains Supply. The problem of supplying the transmitter with alternating current power from the supply mains and turning the transmitter on and off, and "standby" while listening is a problem that can be attacked in many ways, the "best" method being a matter of individual preference.

To make sure that an outlet will stand the full load of the entire transmitter, plug in an electric heater rated at about 50% greater wattage than the power you expect to draw from the line. If the line voltage does not drop more than 5 volts (assuming a 117 volt line) under load and the wiring does not overheat, the wiring is adequate to supply the transmitter. About 750 watts total drain is about the maximum that should be drawn from a 117 volt "lighting" outlet or circuit. For greater power, a separate pair of heavy conductors should be run right from the meter box. For a 1 kilowatt phone transmitter the total drain is so great that a 220 volt "split" system ordinarily will be required. Many of the newer homes are wired with this system, as are homes utilizing electricity for cooking and heating.

If you have a high power transmitter and do a lot of operating, it is a good idea to check on your local power rates if you are on a straight "lighting" rate. In some cities a lower rate can be obtained (but with a higher "minimum") if electrical equipment such as an electric heater drawing a specified amount of current is permanently wired in. It is not required that you use this equipment, and many an amateur who runs his kilowatt phone rig far into the night has made a worthwhile saving on his electric bill by scaring up an old 3 kw. air heater at the secondhand store and permanently installing it in the operating room. Naturally, however, there would be no saving unless you expect to occupy the same dwelling for a considerable length of time.

Probably the most popular transmitter switching system is the one shown in figure 2. All transmitter tube filaments and possibly the speech amplifier plate voltage are turned on by means of one primary switch. With this switch on, the transmitter is in "standby" position (as soon as any mercury vapor rectifiers have once reached operating temperature).

Another switch, the "send-receive" switch SW₂, is connected so as to control all plate transformers except possibly that used for

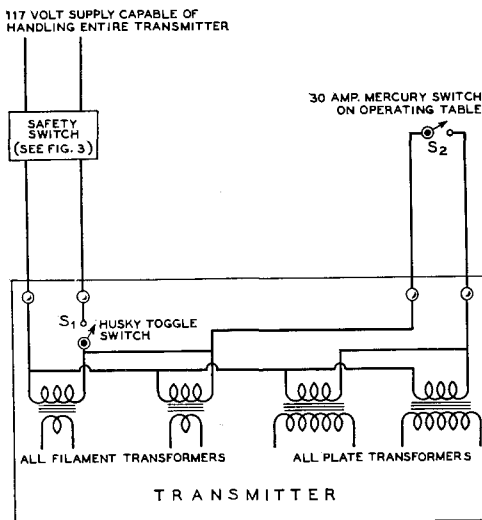

Figure 2.
POPULAR METHOD OF SUPPLYING AND SWITCHING MEDIUM POWER TRANSMITTER.

This arrangement is the one most widely used when the transmitter cannot be reached easily from the operating position. SW₂ should never be turned on until SW₁ has first been on for 15 seconds, preferably 30 seconds. SW₁ should never be turned on except when SW₂ is off; thus SW₂ should always be turned off before SW₁ is turned off.

the speech amplifier (which usually is a combined plate-filament transformer). This is perhaps the simplest method, but requires that the modulator and all r.f. tubes be supplied from filament windings that are not combined with plate windings on the same core. As this is common transformer practice anyway, except for low voltage supplies, no special requirements need be considered when purchasing transformers.

The send-receive switch in this system should be capable of handling the required power with considerable to spare, because of the inductive nature of the load. Thirty ampere mercury switches may be purchased for less than a dollar, and besides having a smooth and positive action, they will last almost indefinitely. They resemble an ordinary house lighting toggle switch in appearance. The latter, costing less than the mercury type, will be found satisfactory in low powered transmitters.

Another popular arrangement is to use fixed safety bias on the entire transmitter, so that the excitation may be removed at the "front end" of the transmitter without any of

the succeeding tubes becoming overheated or going into parasitic oscillation. The transmitter then is turned on and off (or keyed, for that matter) simply by opening and closing the cathode of screen of the oscillator.

To minimize the external wiring, the most common practice is to turn the filaments on right at the transmitter, only the send-receive switch being placed on the operating desk, as in figure 2. When the transmitter is small and is placed right on or beside the operating desk, both filament and send-receive switches may be placed on the transmitter.

Safety Precautions

The best way for an operator to avoid serious accidents from the high voltage supplies of a transmitter is for him to use his head, act only with deliberation, and not take unnecessary chances. However, no one is infallible, and chances of an accident are greatly lessened if certain factors are taken into consideration in the design of a transmitter in order to protect the operator in the event of a lapse of caution. If there are too many things one must "watch out for" or keep in mind there is a good chance that sooner or later there will be a mishap; and it only takes *one*. When designing or constructing a transmitter, the following safety considerations should be given attention.

Grounds. For the utmost in protection, everything of metal on the front panel of a transmitter capable of being touched by the operator should be at ground potential. This includes dial set screws, meter "zero adjuster" screws, meter cases if of metal, meter jacks, *everything* of metal protruding through the front panel or capable of being touched or *nearly* touched by the operator. This applies whether or not the panel itself is of metal. Do not rely upon the insulation of meter cases or tuning knobs for protection.

The B negative or chassis of all plate power supplies should be connected together and to an external ground such as a waterpipe. In the case of a bias supply the B positive should be connected to the common ground.

Exposed Wires and Components. It is not necessary to resort to rack and panel construction in order to provide complete enclosure of all components and wiring of the transmitter. Even with breadboard construction it is possible to so arrange things and incorporate a protective housing which will not interfere with ventilation yet will prevent contact with all wires and components carrying high voltage d.c. or a.c.

If everything on the front panel is at ground

potential (with respect to external ground) and all units are effectively housed with protective covers, then there is no danger except when the operator must reach into the interior part of the transmitter, as when changing coils, neutralizing, adjusting coupling, or shooting trouble. The latter procedure can be made safe by making it possible for the operator to be *absolutely certain* that all voltages have been turned off and that they cannot be turned on either by short circuit or accident. This can be done by incorporation of the following system of main primary switch and safety signal light.

Combined Safety Signal and Switch. The common method of using red pilot lights to show when a circuit is "on" is useless except from an ornamental standpoint. When the red pilot is not lit it *usually* means that the circuit is turned off, but it *can* mean that the circuit is on but the lamp is burned out or not making contact.

To enable you to grab the tank coils in your transmitter with absolute assurance that it is impossible for you to obtain a shock except from possible undischarged filter condensers (see following topic for elimination of this hazard) it is only necessary to incorporate a device similar to that of figure 3. It is placed near the point where the main 110-volt leads enter the room (preferably near the door) and in such a position as to be inaccessible to small children. Notice that this switch breaks *both* leads; switches that open just one lead do not afford complete protection as it is sometimes possible to complete a primary circuit through a short or accidental ground. Breaking just one side of the 110 may be all right for turning the transmitter on and off, but when you are going to stick an arm inside the transmitter, *both* 110 volt leads should be broken.

When you are all through working your transmitter for the time being, simply throw the main switch to neutral. Then you can leave the transmitter and even go on a vacation with absolute peace of mind.

When you find it necessary to work on the transmitter or change coils, throw the switch so that the green pilots light up. These can be ordinary 15-watt green bulbs. One should be placed on the front panel of the transmitter; others should be placed so as to be easily visible when changing coils or making adjustments requiring the operator to reach inside the transmitter. These lamps are inexpensive and as several will draw less than 100 watts from the line, a half dozen may be scattered around the transmitter.

For 100 per cent protection, just obey the

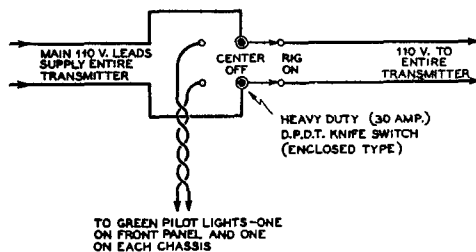

Figure 3.
COMBINED MAIN SWITCH AND SAFETY SIGNAL.

After shutting down the transmitter for the day, throw the main switch to neutral. If you are going to work on the transmitter, throw the switch all the way to "pilot," thus turning on the green pilot lights and making it impossible for there to be primary voltage on any transformer in the transmitter even by virtue of a short or accidental ground. To live to a ripe old age, simply obey the rule of "never work on the transmitter unless green lights are on."

following rule: *never work on the transmitter or reach inside any protective cover except when the green pilots are glowing.* To avoid confusion, no other green pilots should be used on the transmitter; if you want an indicator jewel to show when the filaments are lit, use amber instead of green.

If the main switch is out of reach of small children, a conspicuous sign such as "DO NOT TOUCH UNDER ANY CIRCUMSTANCES" placed on the switch cover will guard against the off chance that someone else would throw the switch unexpectedly. An alternative is to place the switch on the under side of the operating table out of sight. The latter is not so desirable when small children have access to the room.

Safety Bleeders. High capacity filter condensers of good quality hold their charge for some time, and when the voltage is more than 1000 volts it is just about as dangerous to get across an undischarged 4- μ fd. filter condenser as it is to get across a high voltage supply that is turned on. Most power supplies incorporate bleeders to improve regulation, but as these are generally wire wound resistors and as wire wound resistors occasionally open up without apparent cause, it is desirable to incorporate an auxiliary safety bleeder across each heavy duty bleeder. Carbon resistors will not stand much dissipation and sometimes change in value slightly with age. However, the chance of their opening up when run well within their dissipation rating is almost unheard of.

To make *sure* that all condensers are bled it is best to short each one with an insulated

screwdriver. However, this is sometimes awkward and always inconvenient. One can be virtually sure by connecting auxiliary carbon bleeders across all wire wound bleeders used on supplies of 1000 volts or more. For every 500 volts, connect in series a 500,000-ohm 1-watt carbon resistor. The drain will be negligible (1 ma.) and each resistor will have to dissipate only 0.5 watt. Under these conditions the resistors will last indefinitely with no chance of opening up. For a 1500-volt supply, connect three 500,000-ohm resistors in series. If the voltage exceeds an integral number of 500 volt divisions, assume it is the next higher integral value; for instance, assume 1800 volts as 2000 volts and use four resistors.

Do *not* attempt to use fewer resistors by using a higher value for the resistors; not over 500 volts should appear across any single 1-watt resistor.

In the event that the regular bleeder blows, it will take several seconds for the auxiliary bleeder to drain the condensers down to a safe voltage, because of the very high resistance. Hence, it is best to allow 10 or 15 seconds after

turning off the plate supply before attempting to work on the transmitter.

"Hot" Adjustments. Some amateurs contend that it is almost impossible to make certain adjustments such as coupling and neutralizing unless the transmitter is running. The best thing to do is to make all neutralizing and coupling devices adjustable from the front panel by means of flexible control shafts which are broken with insulated couplings to permit grounding of the panel bearing.

If your particular transmitter layout is such that this is impracticable and you refuse to throw the main switch to make an adjustment—throw the main switch—take a reading—throw the main switch—make an adjustment—and so on, then protect yourself by making use of long adjusting rods made from half inch dowel sticks which have been wiped with oil when perfectly free from moisture.

If you are addicted to the use of pickup loop and flashlight bulb as a resonance and neutralizing indicator, then fasten it to the end of a long dowel stick and use it in that manner.

CHAPTER TWELVE

Exciters and Low Powered Transmitters

SIMPLE 15 WATT TWO BAND EXCITER OR TRANSMITTER

Illustrated in figures 1 and 2 is the simplest practical exciter or transmitter for fixed-station use. It uses only one tube and one crystal, and with four easily wound coils provides about 15 watts output on 80 meters and approximately 12 watts on 40. With few exceptions, the parts are all inexpensive standard receiver items. With the particular antenna-coupling circuit illustrated, the unit may be used with a wide variety of antennas, although the simple antenna to be described is strongly recommended. It gives excellent performance on both bands.

The unit operates as a regenerative crystal oscillator of the harmonic type on 40 meters and as a straight tetrode crystal oscillator on 80 meters. The change from one form of oscillator to the other is taken care of automatically when the coils are changed, as a result of the jumper in the 80-meter coil.

If the unit is used as an exciter, the antenna coupling tank L_2 and C_6 may be omitted, the output of the oscillator being link coupled to the following stage instead. The antenna tank circuit illustrated was included in the model shown because it can be used in conjunction with an end-fed wire for two-band operation. If the unit is first used as a transmitter and then later used as an exciter when another stage is added, the antenna tank circuit can be removed from the oscillator unit and used as the grid tank of the amplifier.

Construction. The whole transmitter is built on a $9\frac{1}{2}$ by $6\frac{1}{2}$ by 1 inch thick wooden baseboard to which is mounted a $10\frac{1}{2}$ by $6\frac{1}{2}$ inch "presdwood" front panel.

Baseboard-mounting type bakelite sockets are used for both the tube and the coils. Five-prong sockets are used for the coils and a six-prong one for the tube. Another five-

prong socket of the same type is placed directly behind the tube and used to mount the crystal.

The panel supports the two midget "tank" condensers, C_1 and C_6 , and the 0-100 ma. meter. A small through-type insulator directly above the antenna-tuning condenser is used for an antenna terminal.

The two Fahnestock clips at the right rear of the baseboard are used for key connections. A small four-terminal strip at the left rear of the baseboard provides a convenient method of making heater and plate voltage connections to the power supply. The only other components mounted on either the panel or base are two two-terminal tie points. These are screwed to the baseboard, one between each coil and condenser. They are used to support the coupling links, which will be described later.

Wiring. With the exception of the coupling link, the heater leads, and one of the meter leads, all wiring is done with no. 14 bus-bar. This heavy wire allows the various fixed condensers and resistors to be supported directly from the wiring.

A single piece of bus-bar running along the back of the baseboard between the tube and the crystal, and connected to one of the power supply terminals at one end, and to one of the key terminals at the other is used for a *common ground* lead. All of the ground connections shown on the diagram are made to this lead, which in turn should be connected to a waterpipe or other good external ground.

As may be seen from the diagram, there is a link around each coil. These links couple the plate coil to the simple antenna-matching circuit. The link around the plate coil is three turns of push-back wire, while the one around the antenna coil is four turns of the same type of wire. The links are each $1\frac{3}{4}$ inches in diameter and are permanently connected in

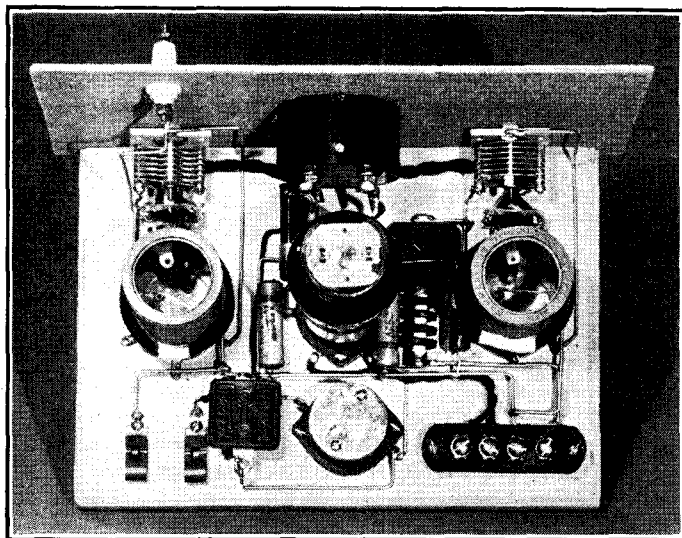

Figure 1.
SIMPLEST PRACTICAL EX-
CITER OR TRANSMITTER.
This unit delivers 12 to 15 watts
on 40 or 80 meters with an 80-
meter crystal. The antenna cou-
pling tank (to the left) can be
omitted if this unit is to be used
only as an exciter.

the transmitter. They are supported by the tie-points previously mentioned. Two small pieces of tape wrapped around each link coil serve to hold the turns together. The link around the plate coil should be placed at such a height above the socket that when the plate coil is plugged in, the link is around the bottom portion of the coil. The bottom of the plate coil should be the end which is connected through C_3 to ground on 40 meters and, by means of the jumper, directly to ground on 80 meters.

The link coil around the antenna coil should be positioned so that it falls at the center of the antenna coil. About six inches of twisted push-back wire is used as a coupling line between the two coils. The twisted line is connected to tie-points at each end of the line.

Coils. The jumper on the 80-meter coil allows the transmitter to work as a conven-

tional tetrode oscillator on 80 meters and as a regenerative oscillator on 40 meters.

The antenna coil connections are the same for both bands. If the socket connections are made as shown in the diagram, the two ends of the coils are connected to the cathode and plate prongs and the center tap to the grid prong.

The leads to the key may be any reasonable length (up to 10 feet, if necessary). A 0.02- μ f.d. condenser, C_7 , is connected directly across the key. This condenser is used to minimize key clicks and is most effective when placed right at the key rather than in the transmitter. Be sure the frame of the key connects to the grounded key terminal and not the terminal that goes to the meter.

Power Supply. The power supply recommended is a standard brute-force filtered affair using receiver components throughout. The parts are mounted on a small baseboard in the most convenient manner and the heater and plate voltage connections brought out to a four-post terminal strip similar to that on the transmitter. The power transformer should not deliver more than 350 v. r.m.s. each side of the c.t. or else the peak voltage on the filter condensers will be too high when the key is up.

Antenna. The best type of antenna for use with this transmitter is the end-fed half-wave 80-meter type. Such an antenna, if erected reasonably in the clear, will give good results on both 80 and 40 meters. On both bands the antenna is not particularly direc-

COIL TABLE

Band	Plate Coil	Antenna Coil
80	41 turns, close-wound	50 turns, center - tapped, close-wound
40	21 turns, spaced to a length of two inches	26 turns, center - tapped, spaced to a length of two inches

All coils wound with no. 20 double-cotton-covered wire on 1½" dia. forms.

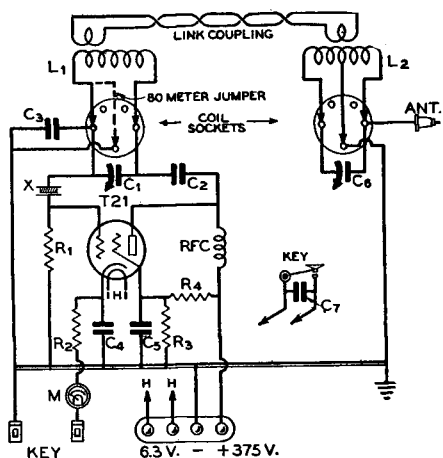

Figure 2.

THE R.F. PORTION OF THE TRANSMITTER.

- | | |
|---|---|
| C ₁ —50- μ fd. midget variable | R ₁ —100,000 ohms, 1 watt |
| C ₂ —01- μ fd. mica | R ₂ —400 ohms, 10 watts |
| C ₃ —0005- μ fd. mica | R ₃ —20,000 ohms, 10 watts |
| C ₄ , C ₅ —01- μ fd. 600-volt tubular | R ₄ —5000 ohms, 10 watts |
| C ₆ —50- μ fd. midget variable | RFC—2.5-mh., 125-ma. choke |
| C ₇ —02- μ fd. 600-volt tubular | X—80-meter X or AT crystal |
| | L ₁ , L ₂ —See coil table |
| | M—0-100 milliamperes |

tional, although a slight increase in signal strength will be noticed in certain directions. On 40 meters the antenna produces low-angle radiation, an advantage in working dx.

The antenna should measure 135 feet from the far end to the antenna terminal on the transmitter and be erected in the clear and as high and as much in a straight line as possible.

Tuning Up. If all the wiring has been done properly, no difficulty should be experienced in placing the transmitter in operation. Leads to the power supply and key should be connected (ordinary lamp cord of good quality will do) and a 6.3-v. 150-ma. dial light placed in series with the antenna at the transmitter. A crystal with a frequency between 3502 and 3648 kc. should be placed in the crystal socket. A crystal in this range will allow operation on both the 80- and 40-meter bands.

When the transmitter is properly adjusted for 80-meter operation it should be possible to tune the antenna coupling circuit through resonance without pulling the oscillator out of oscillation. The dial light should increase in brilliance as the antenna circuit is tuned up to resonance and then decrease as it is detuned on the other side.

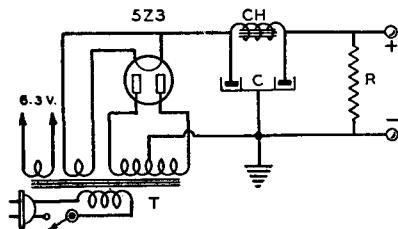

Figure 3.

RECOMMENDED POWER SUPPLY.

- | | |
|--|---|
| T—700 v.c.t., 90 ma.; 5 v., 3 a.; 6.3 v., 3 a. | C—Dual 8 μ fd. electrolytic, 450 v. |
| CH—30 hy., 110 ma. | R—40,000 ohms 20 watts |

When this condition is obtained, remove the dial lamp from the antenna and make the antenna connection directly to the antenna post. Then, without touching the antenna-tuning condenser, turn the plate condenser toward maximum capacity until the point of maximum capacity at which the circuit will still oscillate is found. The final adjustment of the plate condenser should be made while listening to the signal from the transmitter in a monitor or receiver. The condenser should be set at the furthest point toward maximum capacity at which the keying is clean and distinct without chirps or lag.

The farther down the plate coil the coupling link is placed, the looser the coupling to the antenna circuit. If the coupling is too tight, the oscillator won't oscillate or the note will be chirpy. If the coupling is too loose, the full power will not be delivered to the antenna.

The coupling should be adjusted by varying the position of the *plate coil coupling link*, never by detuning the antenna condenser. The latter should always be tuned to resonance. If it cannot be tuned to resonance without the transmitter's going out of oscillation or developing keying chirps, the coupling is too tight.

If the dial lamp in the antenna lead does not give sufficient indication to be observed handily, a 2-volt 60-ma. bulb may be substituted. Do not use a 60-ma. lamp unless you are unable to get a satisfactory indication on a 150-ma. bulb. The maximum antenna current will be low at this point (a current "node") and will vary somewhat in different antenna installations.

On 40 meters the tuning is somewhat simpler, because the transmitter acts as a regenerative harmonic oscillator and will oscillate and key cleanly regardless of how heavily the plate circuit is loaded. Therefore it is necessary only to tune for greatest out-

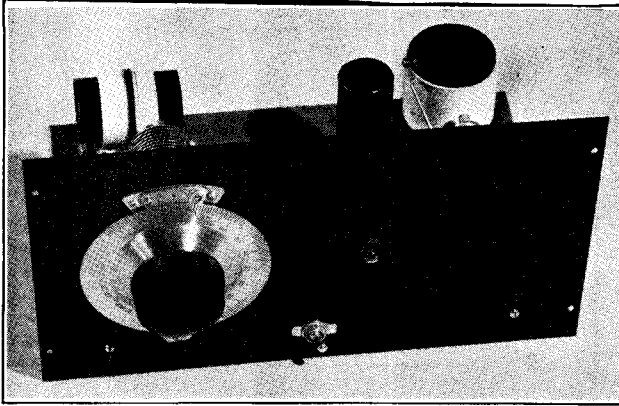

Figure 4.
10-15 WATT V.F.O. EXCITER,
80 AND 160 M. OUTPUT.
This unit, which provides virtual
crystal stability, may be substituted
for an 80 or 160 meter crystal
oscillator with the advantage of con-
tinuous band coverage.

put, without regard to keying chirps or non-oscillation.

When the unit is used as an exciter the tuning is the same except that instead of tuning for greatest brilliancy of the lamp in the antenna lead, adjustments should be made for maximum grid current to the following stage. Coupling is adjusted as described for operation with an antenna; the position of the link around L_1 is varied until the desired coupling is obtained. *Be sure to turn off the power supply* before making coupling adjustments.

10 WATT V.F.O. TYPE EXCITER

The unit illustrated in figures 4 to 7 will deliver between 10 and 15 watts output anywhere between 1750 and 2000 kc. or between 3500 and 4000 kc. It consists of a stabilized variable frequency oscillator working in the 1750-2000 kc. range, a 6V6 or 6L6 untuned class A amplifier which acts as an isolating stage, and a 6L6 output stage with a tank that will hit both the fundamental and second harmonic of the oscillator frequency. The output is at least 10 watts when doubling and

Figure 5.
REAR VIEW OF 10-15 WATT
V.F.O. EXCITER UNIT.

For best results the various components should be arranged approximately as shown here. The small ceramic padder C_5 may be seen soldered directly across the oscillator tuning condenser terminals.

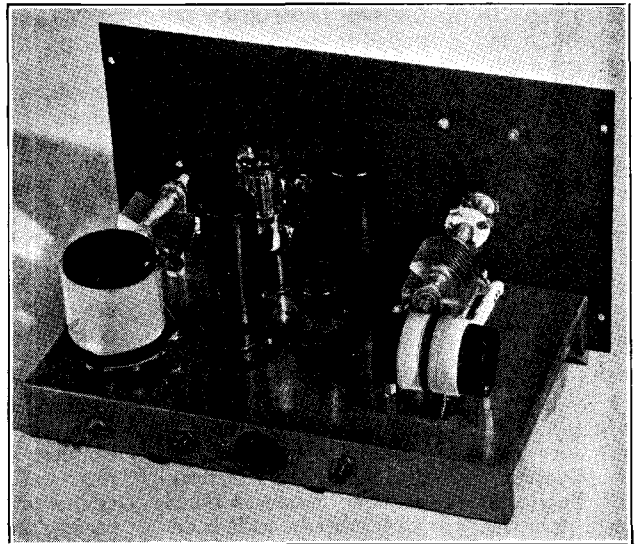

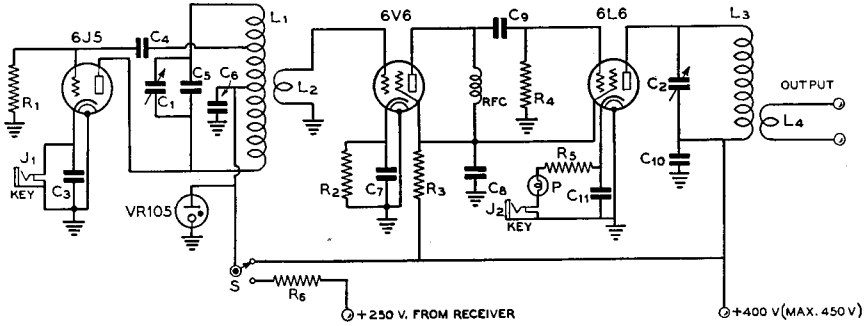

Figure 6.

GENERAL WIRING DIAGRAM OF 10-15 WATT V.F.O. UNIT.

C₁, C₂—150- μ fd. semi-circular plate type midget condensers, double bearing type
 C₃—0.5- μ fd. tubular 400 v.
 C₄—100- μ fd. midget mica
 C₅—Centralab ceramic capacitor, zero co-

efficient type, 350 μ fd.
 C₆, C₇, C₈—0.5- μ fd. tubular, 400 v.
 C₉—0.1- μ fd. tubular, 400 v.
 C₁₀—0.5- μ fd. tubular, 400 v.
 C₁₁—0.5- μ fd. tubular, 400 v.

R₁—50,000 ohms, 1 watt
 R₂—400 ohms, 10 watts
 R₃—4000 ohms, 10 watts
 R₄—100,000 ohms, 1 watt
 R₅—400 ohms, 10 watts

R₆—5000 ohms, 2 watts
 P—150-ma. dial light bulb (type 40 or 47)
 S—S. p. d. t. toggle switch
 Coils—See text
 RFC—8-mh. r.f. choke

considerably more than 10 watts when working straight through. Because of the untuned isolating stage, neutralization of the 6L6 is not required when working straight through.

The unit is designed to replace the conventional crystal oscillator working on 80 or 160 meters, and will drive satisfactorily any buffer or doubler that can be driven by a crystal oscillator. This assumes an existing transmitter that already has doublers to per-

mit operation on the higher frequency bands. When such is not the case, the cascade doubler described later in this chapter is recommended for use with the v.f.o. unit. If desired, these two units can be mounted on a single standard rack chassis and 19-inch panel, thus making a composite unit delivering power on any band from 10 to 160 meters.

The 6J5 Hartley oscillator is very lightly loaded and is protected from plate voltage

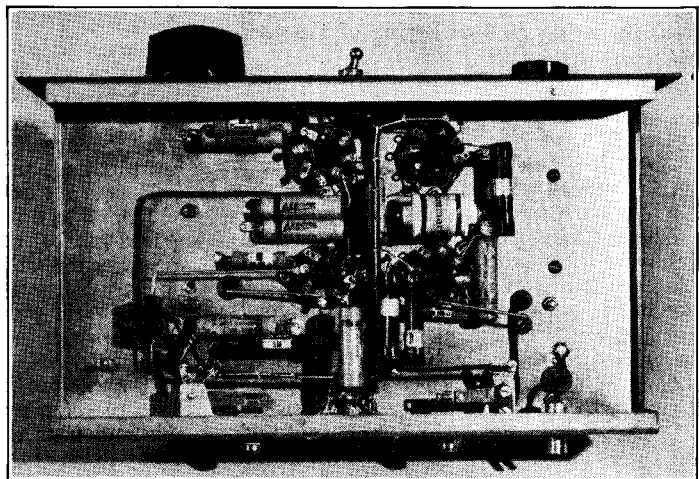

Figure 7.
 UNDER-CHASSIS VIEW OF
 10-15 WATT V.F.O. EXCITER

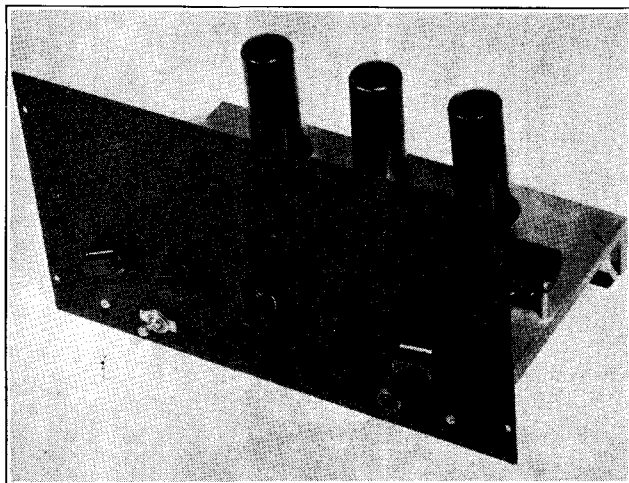

Figure 8.
MULTI-BAND FREQUENCY
MULTIPLIER.

This unit delivers approximately 15 watts on 10, 20 or 40 meters when supplied with 80-meter excitation. No coils need be changed when changing bands.

changes resulting from keying or line voltage variation by means of a VR-105-30 gaseous voltage regulator.

To permit "spotting" the oscillator frequency by listening to it on a receiver, without the necessity for turning on the whole transmitter, switch S is provided.

It will be noticed that no meter is included in the unit. A small 150-ma. dial lamp, P, serves as a resonance indicator for the output tube, and no such indicator is required on the untuned 6V6 stage. The 6L6 output stage is resonated by tuning condenser C_2 for minimum brilliancy of the lamp.

Either the oscillator or the output stage may be keyed. Keying of the output stage will result in a slightly cleaner note on the higher frequency bands, but does not permit break-in keying as does keying of the oscillator.

Construction

The unit should be constructed on a metal chassis and metal front panel, and preferably should be housed in a metal cabinet. The oscillator tuning condenser must be mounted rigidly and driven through an insulated coupling by means of an accurate and smooth vernier dial. The oscillator coil and the padding condenser C_5 are placed so as to be as far as possible from the tubes, especially the 6L6, to minimize frequency drift resulting from heating of the tank circuit elements.

The oscillator tank coil and the output tank coil are mounted as far apart as possible and oriented with respect to each other for mini-

mum coupling, in order to keep the output stage from reacting on the oscillator when both tanks are tuned to the same frequency.

The pilot lamp resonance indicator projects through a rubber grommet in the center of the front panel. All connections are made to the rear of the chassis.

Coil Data. The oscillator coil consists of 24 turns of no. 18 d.c.e. wound on $1\frac{1}{2}$ inch dia. bakelite tubing, tapped at the sixth and twelfth turns from one end, the latter tap being the exact center tap.

The amplifier coil consists of 42 turns of no. 20 d.c.e. close wound on 2 inch dia. bakelite tubing.

Two turns of hookup wire (L_2) are wound around the exact center of the oscillator coil, and serve as coupling to the untuned buffer stage.

The oscillator coil is close wound, and then the turns are spread slightly as necessary in order to allow the tuning dial to cover the entire 160 meter band. It will just do this with the specified tuning condenser if the coil turns are adjusted properly.

The output link from the 6L6 tank consists of from 3 to 6 turns of hookup wire (the required number of turns being determined by experiment) wound around the "cold" end of L_3 . For coupling from the unit, either twisted pair (hookup wire) or coaxial cable (hookup wire covered with shield braid) may be used.

If a cabinet is used, it should have vent holes placed near the bottom on the oscillator side and near the top on the opposite end. This will carry the heat generated by the tubes away from the oscillator tank components.

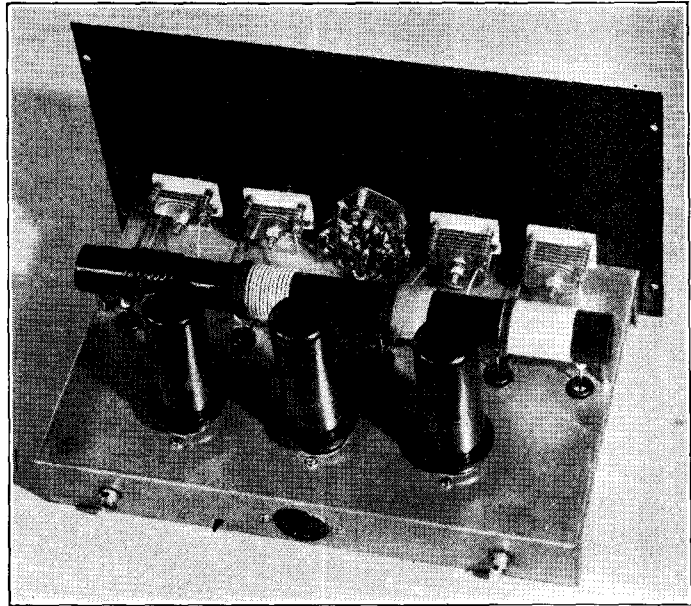

Figure 9.
SHOWING CONSTRUCTION
OF MULTI-BAND FRE-
QUENCY MULTIPLIER

MULTI-BAND FREQUENCY MULTIPLIER

The cascaded doubler unit illustrated in figures 8-11 will provide approximately 15 watts output on 10, 20, and 40 meters when supplied with 80-meter excitation. Either an 80-meter crystal oscillator or the v.f.o. unit just described may be used for excitation.

The unit consists of three 6L6 doubler stages, with provision for coupling out of any of them by means of a switch in the link circuit. This same switch also applies full screen voltage to the particular 6L6 which happens to be serving as the output tube, the others running at reduced screen voltage.

Provision is also made for providing output on the excitation frequency. This is done simply by shunting the input link to the output terminal by means of S_1 .

Except for the switching arrangement, the circuit is perfectly straightforward excepting possibly for the incorporation of fixed battery bias. A standard duty 45-volt bias battery costs no more than cathode resistors and bypass condensers for the three stages, will last for at least 2 years, and permits better oscillator keying.

Construction

The construction is shown clearly in the illustrations. A 7 x 11 inch chassis supports

a 7 x 12 inch front panel. As the tank coils are all tuned to different bands, there is no need for taking special precautions to avoid coupling between coils. All four coils are wound on a single 10½ inch length of 1 inch dia. bakelite tubing. If desired, the coils can just as well be wound on four separate forms. Tuning condensers are supported from the chassis (not the panel) by means of brackets furnished by the manufacturer.

Coils. The 80-meter coil consists of 48 turns of no. 24 d.c.c. close wound, with a two turn link at the ground end.

The 40-meter coil consists of 23 turns of no. 20 d.c.c., close wound, with a three turn link at the ground end.

The 20-meter coil consists of 13 turns of no. 18 d.c.c., spaced to one inch, with a three turn link at the ground end.

The 10-meter coil consists of 8 turns of no. 16 enamelled, spaced to 1 inch, with a two turn link at the ground end.

All coupling links are wound with no. 18 pushback hookup wire.

Operation. When the three stages are properly resonated, only slight readjustment of the tuning knobs will be required to peak up the output when changing bands or from one end of the band to the other. When the unit is tuned up initially, care should be taken to see that the 40 meter coil is tuned to the second and not the third harmonic of 80 meters.

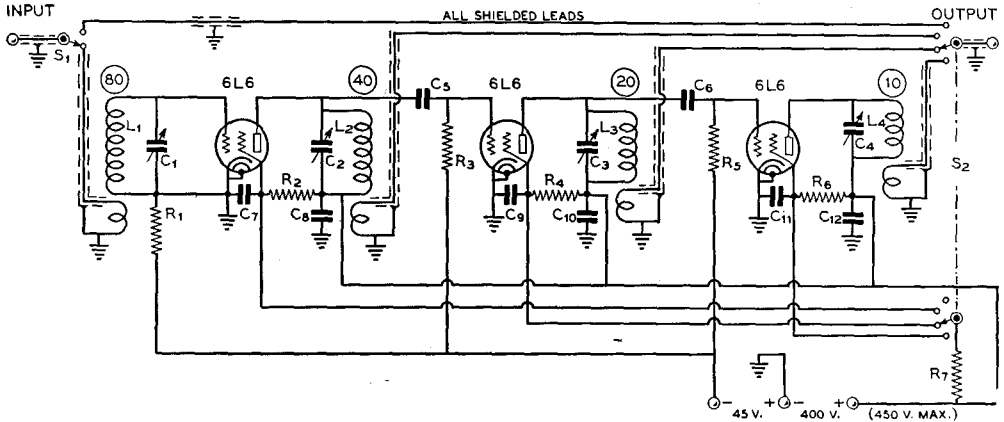

Figure 10.

SCHEMATIC DIAGRAM OF MULTI-BAND FREQUENCY MULTIPLIER.

- | | | | |
|---|--|--|--|
| C ₁ , C ₂ —35- μ fd. mid-
get variable | mica | R ₄ —50,000 ohms, 2
watts | |
| C ₃ , C ₄ —25- μ fd. mid-
get variable | R ₁ —100,000 ohms, 2
watts | R ₅ —100,000 ohms, 2
watts | S ₁ —Single-pole double-
throw toggle switch |
| C ₅ , C ₆ —25- μ fd. mid-
get mica fixed | R ₂ —50,000 ohms, 2
watts | R ₆ —50,000 ohms, 2
watts | S ₂ —2-pole 4-throw
rotary switch |
| C ₇ to C ₁₂ —.003- μ fd. | R ₃ —100,000 ohms, 2
watts | R ₇ —15,000 ohms, 10
watts | Coils—See text |

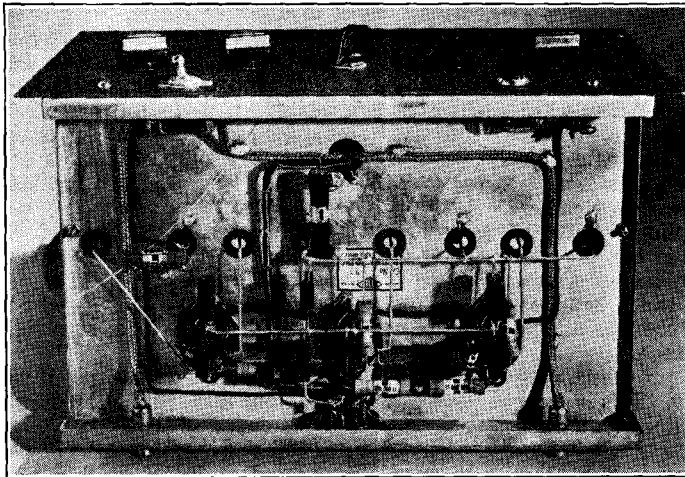

Figure 11.
**UNDER-CHASSIS VIEW
OF MULTI-BAND FRE-
QUENCY MULTIPLIER.**

Auto radio antenna couplers are used for making link connections in and out of the unit. Either shielded solid conductor or twisted hookup wire may be used for the link coupling line.

**100 WATT BANDSWITCHING
EXCITER OR TRANSMITTER**

In the illustrations (figures 12, 13 and 14) is shown a unit delivering approximately 100 watts output on all bands from 10 to 160 meters without need for changing coils. Coil switching is incorporated in all three stages of the unit. Using an 814 beam tetrode in the last stage, the output approaches 100 watts on

10 meters and is well in excess of 100 watts on all lower frequency bands.

The oscillator is a conventional 6L6 tetrode type with a tank coil circuit that hits both 80 and 160 meters simply by rotating the condenser plates. To accommodate 40-meter crystals a shorting switch is connected to a tap on the coil to permit shorting out of sufficient turns to hit 40 meters. The oscillator is run at moderate plate voltage and very low

screen voltage to keep the r.f. crystal current low, as not much output is required to drive the 807 stage.

The 807 buffer utilizes a manufactured type midget coil turret to permit output on all bands simply by throwing the coil switch. However, the 10-meter section is not used, inasmuch as the output of the 807 is not sufficient when quadrupling from 40 meters to drive the 814; the latter requires somewhat more excitation on 10 meters than on the other bands due to relatively high input capacity and resulting tank circuit losses with capacity coupling.

The 814 stage thus may be driven either on 1 or 2 times crystal frequency, and the 814 stage may be run either straight through or as a doubler, the efficiency being nearly as good when doubling as when working straight through as a result of high bias and adequate excitation. Thus output from the 814 is available on 1, 2, or 4 times crystal frequency.

As the oscillator tank is mounted below the chassis and the buffer and 814 amplifier tanks are separated by a shield baffle above the chassis, all three stages are effectively shielded from each other. This results in stable operation when working "straight through."

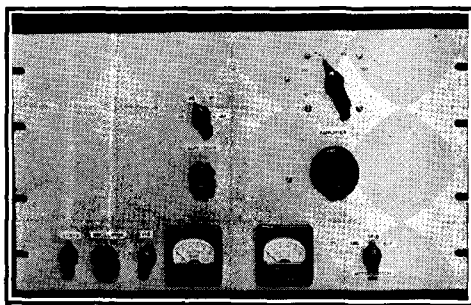

Figure 12.

100-WATT 10-160 METER BAND-SWITCHING EXCITER.

This exciter delivers about 90 watts on 10 meters and well over 100 watts on lower frequency bands.

Three crystal sockets and a crystal switch permit selection of three crystals from the front panel. The leads from the crystal sockets to the 6L6 grid via the crystal switch should be made as short and direct as possible. In fact, when a 40-meter crystal is used it is advisable to place it in the front crystal socket.

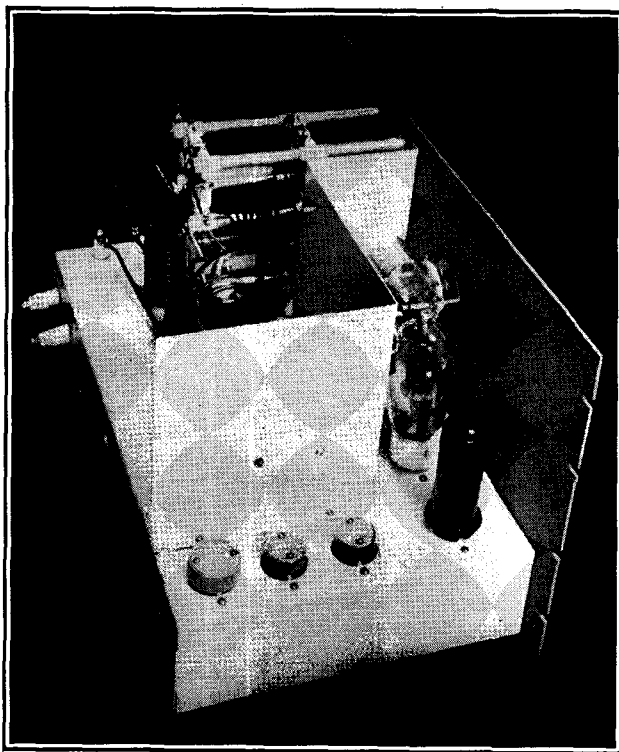

Figure 13.
**REAR VIEW OF EXCITER
SHOWING OSCILLATOR AND
BUFFER.**

The 814 plate tank and bandswitch may be seen behind the shield baffle separating the oscillator and buffer from the final stage.

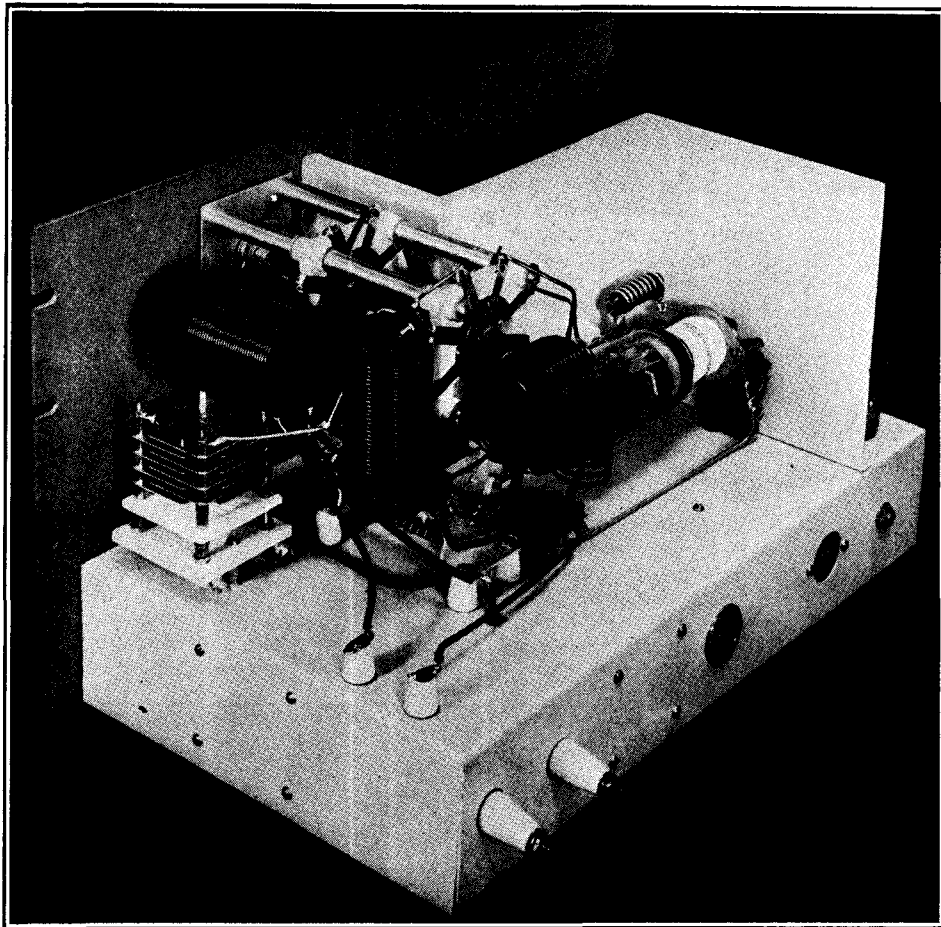

Figure 14.

814 OUTPUT AMPLIFIER OF 100-WATT BANDSWITCHING EXCITER.

Four of the five coils are visible in this photo. The 10-meter coil is hidden by the bandswitch and tank condenser. The fixed air padding condenser, permanently connected across the 160-meter coil, may be seen in the left foreground.

The particular method of connecting the low voltage power supply permits both screen voltage and fixed bias to be obtained for the 814, at the same time providing a desirable compensating action which keeps the 814 grid current from rising to dangerously high values when the load is removed. This compensating effect is obtained with grid leak bias and screen voltage from a series dropping resistor but is not obtained with ordinary fixed bias and fixed screen voltage. With the system shown it is important that the B—500 and B—1250 volt leads are *not* connected together as is common practice.

The 814 plate tank consists of a husky, two-gang band switch and five coils; data for winding the latter are given in the coil table. To provide a low minimum tuning capacity for good 10-meter efficiency yet sufficient capacity to give a good "Q" on 160 meters, a 100- $\mu\mu\text{fd.}$ variable condenser is used for tuning and the 160-meter coil is permanently shunted by a 50- $\mu\mu\text{fd.}$ air padder.

Both to permit shortest possible leads and as a safety precaution, the 814 tuning condenser is set back from the front panel and driven by means of an extension shaft and insulated coupling. The rotor of this con-

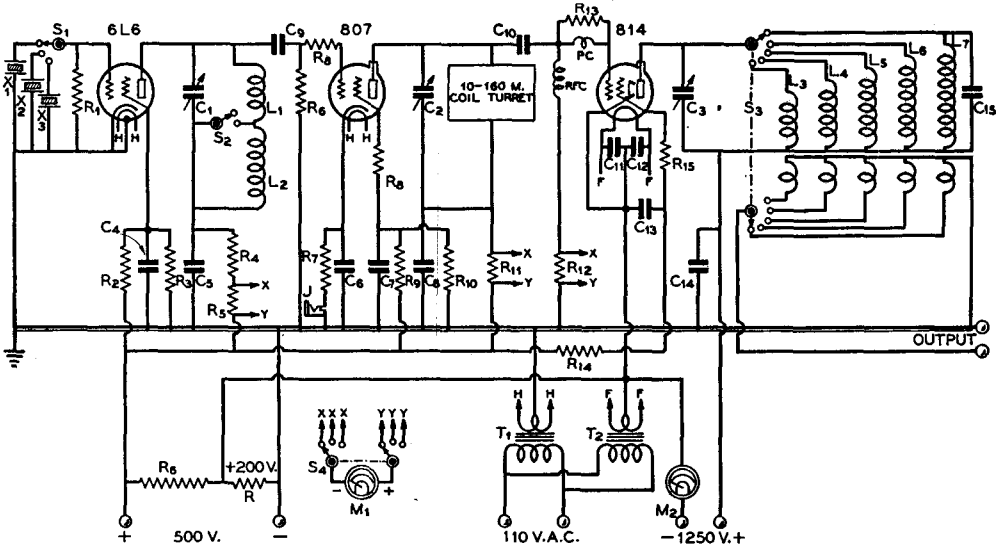

Figure 15.

WIRING DIAGRAM OF BANDSWITCHING 814 EXCITER.

- R—4000 ohms, 25 watts
- R₁—50,000 ohms, 1 watt
- R₂—50,000 ohms, 1 watt
- R₃—60,000 ohms, 2 watts
- R₄—2500 ohms, 10 watts
- R₅—50 ohms, 1 watt
- R₆—100,000 ohms, 2 watts
- R₇—750 ohms, 10 watts

- R₈—50 ohms, 1 watt
- R₉—100,000 ohms, 1 watt
- R₁₀—50,000 ohms, 2 watts
- R₁₁, R₁₂—50 ohms 1 watt
- R₁₃, PC—Parasitic suppressor
- R₁₄—5000 ohms, 10 watts
- R₁₅—50 ohms, 1 watt
- C₁—140- μ fd. midget variable
- C₂—100- μ fd. midget variable

- C₃—100- μ fd. variable 3000 v. spacing
- C₄, C₅, C₆, C₇, C₈—.003- μ fd. midget mica, 1000 v. test
- C₉—25- μ fd. midget mica, 1000 v. test
- C₁₀—100- μ fd. mica, 1000 v. test
- C₁₁, C₁₂, C₁₃—.003- μ fd. midget mica, 1000 v. test
- C₁₄—.002- μ fd., 5000 v. test
- C₁₅—50- μ fd. air padder, 4000 v.

- spacing
- M₁—0-100 ma. d.c.
- M₂—0-250 ma. d.c.
- T₁—6.3 v. 2 amp.
- T₂—10 v. 4 amp.
- S₁—Single-pole 3-throw "tone control" switch
- S₂—Single-pole 2-throw "tone control" switch
- S₃—High power two-gang five position bandswitch
- S₄—Double-pole rotary meter switch

COIL DATA

For 100-Watt Bandswitching Exciter

OSCILLATOR COIL

74 turns of no. 22 d.c.c. close wound on 3 1/2 in. length of 1 in. dia. bakelite tubing, tapped at 24th turn. L₁ is 40-meter section (24 turns).

BUFFER COIL

Manufactured 10-160 meter midget coil turret. 10-meter tap not used.

814 PLATE COILS

10 Meters

6 turns no. 12 enamelled 1 1/8 in. dia. spaced to 1 1/8 in. (Wound on 1 in. form and form removed.) Link 1 turn at cold end.

20 Meters

11 turns no. 12 enamelled 1 1/8 in. dia. spaced to 2 in. (Wound on 1 in. form and form removed.) Link 1 turn at cold end.

40 Meters

18 turns no. 12 enamelled 1 3/4 in. dia. spaced to 2 1/4 in. and turns held in place with two celluloid strips cemented to coil with duco cement. Link 2 turns at cold end.

80 Meters

32 turns no. 12 enamelled close wound on 3 1/2 in. length of 1 1/2 in. dia. bakelite tubing. Link 3 turns at cold end.

160 Meters

44 turns no. 14 enamelled close wound on 3 3/4 in. length of 2 in. dia. bakelite tubing. Link 4 turns at cold end.

All links wound with solid no. 16 having high voltage insulation.

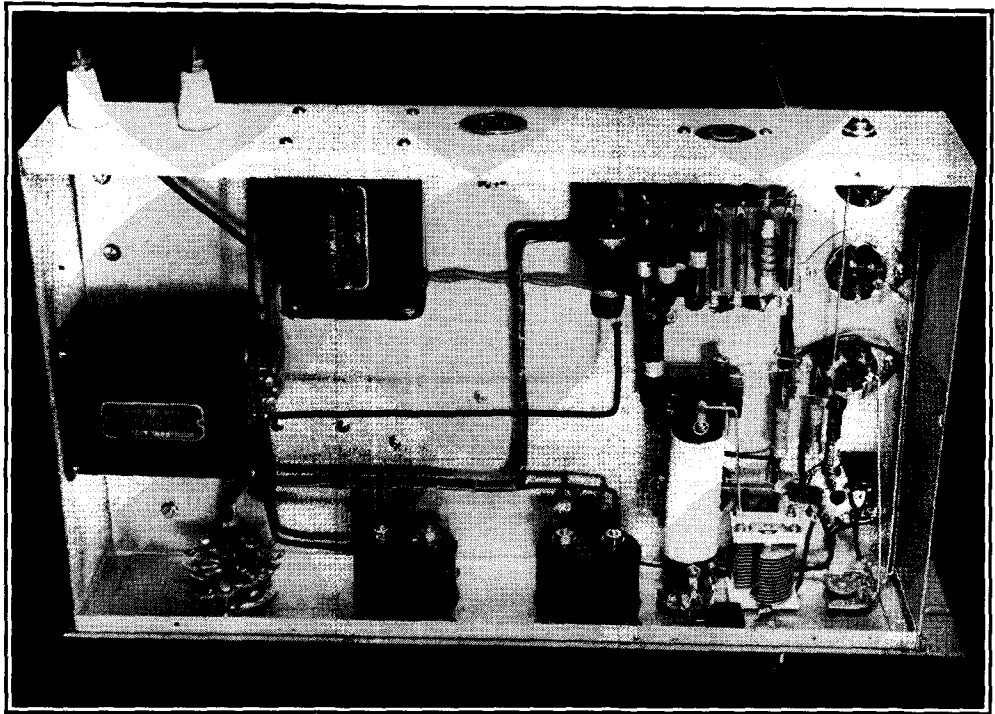

Figure 16.

UNDER-CHASSIS OF THE 100-WATT 814 BANDSWITCHING EXCITER.

The tapped oscillator coil may be seen to the lower right. Most of the resistors are mounted on a terminal strip for the sake of neatness. The meter switch may be seen to the left of the two meters.

denser is 1250 volts above ground and the insulated coupling makes it unnecessary to rely upon the insulation of the tuning knob, a bad practice when the voltage is as high as this. The rotor of C_1 and the rotor of C_2 are also above ground, but as the voltage is not particularly high it is only necessary to use knobs with well protected set screws. These two condensers are insulated from the chassis by means of fiber washers.

A 250-ma. meter is permanently connected in the B negative of the 814. Because screen voltage is derived from the low voltage power supply, the meter reads plate current only; it is not necessary to allow for the screen current when reading this meter. A 100-ma. meter is used to measure current in the various oscillator and buffer circuits by means of a meter switch.

U.h.f. parasitic suppressors are used both in the 807 and 814 stages. These consist of 50-ohm resistors in the 807 control grid and screen grid leads, and a 50-ohm resistor in the 814 screen and regular parasitic suppressor

in the 814 control grid. These suppressors also eliminate all tendency towards instability when working "straight through" on crystal frequency.

The 10- and 20-meter coils must be mounted with very short leads to the 814 coil switch. The leads to the other three coils are not so important. There is bound to be some coupling (both capacitive through the switch and inductive as a result of the unshielded coils) between the high-frequency coils when being used and the low-frequency coils which are left "floating." This is because the 40-meter coil hits fairly close to 10 meters with nothing in shunt and the 80-meter coil self-resonates near 20 meters. The coils were so designed and placed that the effect is not particularly serious, but small sparks can be drawn from the unused tanks. Fortunately this results in but little loss in efficiency when the 814 stage is loaded, but it does keep the unloaded minimum plate current from being as low as would be the case were plug-in coils used.

On 10 meters the plate current should not be allowed to run over 100 ma. or the plate dissipation will be exceeded. On other bands the plate current should be kept below 110 ma. when doubling and below 130 ma. when working "straight through." The grid current should be adjusted to about 10 ma. when working straight through and about 15 or 20 ma. when doubling. Under no conditions should the grid current be allowed to run over 20 ma. when the 814 is loaded.

The grid current to the 814 can be adjusted by detuning the 807, as the 807 is run at such low screen voltage that it will not draw excessive plate current or overheat when detuned.

The particular bandswitch used for the 814 plate tank has six positions, which leaves one extra. Instead of being left blank this posi-

tion is jumpered to the 160 meter switch point. This makes it impossible to remove plate voltage from the 814 by throwing the switch to the unused position. Tubes such as the 814 can be permanently damaged by running them with full screen voltage and no plate voltage.

When mounting the 814 socket, be sure to orient it so that the position of the 814 will correspond to that recommended for horizontal mounting in the manufacturer's application notes. In wiring the 814 socket be sure to connect the beam forming plates to the *filament return* instead of to ground as is the more common practice. Connecting the beam forming plates to ground in this case will put 200 volts negative bias on them, greatly reducing the output of the stage.

CHAPTER THIRTEEN

Medium and High Power R.F. Amplifiers

The amplifiers shown on the following pages are typical of those that have through popular use become the standard type of r.f. amplifier for power outputs of from 200 to 800 watts. Most of those illustrated are of the push-pull type, because of the advantages possessed by a balanced circuit. However, a representative single ended amplifier is shown in figure 9. It will be noticed that this amplifier is essentially the same as a push-pull amplifier except that one tube and one neutralizing condenser are removed.

Standard Push-Pull Amplifier

A standard push-pull amplifier circuit is shown in figure 1. While some variations in the method of obtaining the bias are possible, and certain methods are better adapted than others to certain applications, the basic r.f. circuit remains the same. All of the push-pull amplifiers illustrated in this chapter use this basic circuit.

The recommended method of obtaining bias for c.w. or plate modulated telephony is to use just sufficient fixed bias to protect the tubes in the event of excitation failure and obtain the rest from a grid leak. However, the grid leak may be returned directly to the filament supply if an overload relay is incorporated in the plate circuit, the relay being adjusted to trip immediately when excitation is removed. For grid modulation it is necessary that all the bias be obtained from a fixed source; this makes a grid leak impracticable for this class of service.

It will be noticed that J_2 is placed in the filament return rather than in positive high-voltage lead. This is a safety precaution. When connected as shown in the diagram, J_2 will read plate current only, as J_1 is returned to the "hot" side of J_2 instead of to ground.

This will require an extra external lead if fixed bias is used, as the positive of the bias supply cannot be connected to ground under these conditions without resulting in a short across the meter jack J_2 .

When measuring current in the filament return of filament type tubes, it is necessary that the stage have *either* an individual power supply or else a filament supply which is not used to supply any other *filament type* tubes (heater tubes may be operated from the same filament supply). If this requirement is not met, a meter jack will read the current being drawn by more than one stage at the same time. If desired individual meters may be substituted for the two meter jacks in figure 1.

On the low frequency bands a plate r.f. choke will not always be required with this type of amplifier. However, one is usually desirable on the higher frequency bands, and as the choke does no harm in any case its incorporation is recommended.

The grid leak R_1 serves effectively as an r.f. choke in the grid circuit because the r.f. voltage impressed upon it is very low, and no grid r.f. choke is required when a grid leak is used. However, if no grid leak is incorporated, as would be the case for fixed bias for grid modulation, an r.f. choke should be substituted for R_1 . It should not resonate with the plate choke or there may be a low frequency parasitic oscillation. A 200-ohm 10-watt wirewound resistor in series with the grid r.f. choke will suppress this type of parasitic oscillation without otherwise affecting the operation of the amplifier.

It will be noted that the rotor of the plate tank condenser is left "floating" (ungrounded). This permits a tank condenser of less spacing to be used, as there is no d.c. impressed across it. When the rotor is left

FIGURE 1. STANDARD PUSH-PULL R.F. AMPLIFIER CIRCUIT.

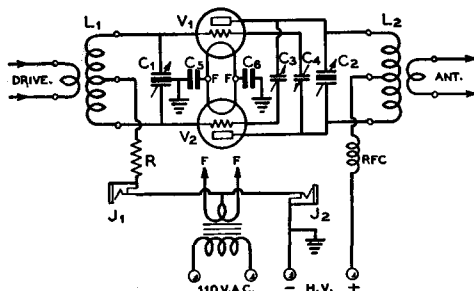

The mechanical design must be symmetrical and the output coupling must be evenly balanced. Individual meters may be substituted for the two meter jacks. If a grid r.f. choke is substituted for R_1 for fixed bias operation, a 200-ohm wirewound resistor should be placed in series if a low frequency parasitic oscillation occurs.

C_1 —Approx. 1 $\mu\text{fd.}$ per section per meter of wavelength. 1000 volt spacing for HK54, 35T, T55, 812, 808, etc. 2000-volt spacing for 100TH, HK254, HF200, T200, etc.

C_2 —Refer to tank condenser data and Q charts in chapter 7 for capacity and spacing.

C_3, C_4 —Suitable neutralizing condensers, 50% greater air gap than C_2 .

C_5, C_6 —0.002 $\mu\text{fd.}$ or larger.

R_1 —Of such value that normal grid current for tubes will produce enough voltage drop to make a total of twice cut-off bias including any fixed bias. Higher resistance can be used with slight increase in efficiency if reserve of excitation is available. Wattage rating equal to I^2R .

RFC—2.5-mh. r.f. choke designed for all-band operation, of suitable d.c. rating. Not always found necessary.

T_1 —Filament transformer of suitable voltage and current rating. Tapped primary desirable, especially if transformer is located some distance from the amplifier.

“floating” it is imperative that the amplifier be symmetrical from a physical standpoint and that the coupling to the external load be symmetrical. Because the rotor will be at high d.c. potential if the condenser should over, it is advisable to use an insulated coupling between the rotor shaft and the tuning dial or knob.

In cases where it is impossible to obtain equal loading of the two tubes in the push-pull amplifier, it may become necessary to ground the rotor of the plate condenser through a by-pass condenser. If the stage is plate modulated it may be necessary to connect the rotor of the condenser to the modulated plate voltage lead through a 100,000 ohm resistor to prevent the condenser from arcing between stator and rotor on modulation peaks. The resistor may be a 1-watt carbon unit. When this type of circuit is used, the by-pass condenser between the rotor and ground should not have a capacity of more than .002 $\mu\text{fd.}$, since a large condenser will not allow the voltage impressed on the rotor to follow the modulation.

Because of the high minimum capacity of tuning condensers having sufficient maximum capacity for proper 160-meter operation, it is good practice to use a split stator plate tuning condenser just sufficiently large for 40-meter c.w. operation (about 75 $\mu\text{fd.}$ per section for commonly used ratios of plate voltage to plate current) and then use external plug-in fixed padding condensers for 80- and 160-meter operation. The cost is about the

same as for a split stator condenser having sufficient capacity for 160-meter phone operation, and the efficiency on 10 and 20 meters is higher because of the lesser bulk and minimum capacity of the tuning condenser. In the low and medium power range, fixed air padders are the least expensive; for high power operation, fixed vacuum condensers are about as economical as the regular air types. Recommended values of tank circuit capacity for different bands and applications are given in *Chapter Seven*.

As the power in the grid circuit is so much lower than in the plate circuit, it is customary to use a split stator grid condenser with sufficient capacity for operation on the lowest frequency band and also to ground the rotor. A physically small condenser has a greater ratio of maximum to minimum capacity, and it is possible to get a grid condenser that will be satisfactory on all bands from 10 to 160 meters without need for external auxiliary capacitors. As both r.f. and d.c. voltages are relatively low in the grid circuit the rotor of the condenser can be grounded without increasing the cost appreciably, as very little more spacing will be required and the condenser is relatively small anyway (in comparison to the plate tank condenser). Grounding of the rotor simplifies mounting of the condenser and also provides circuit balance and insures electrical symmetry. It also retards u.h.f. parasitics by bypassing them to the ground in the grid circuit.

For high power operation on 10 and 20

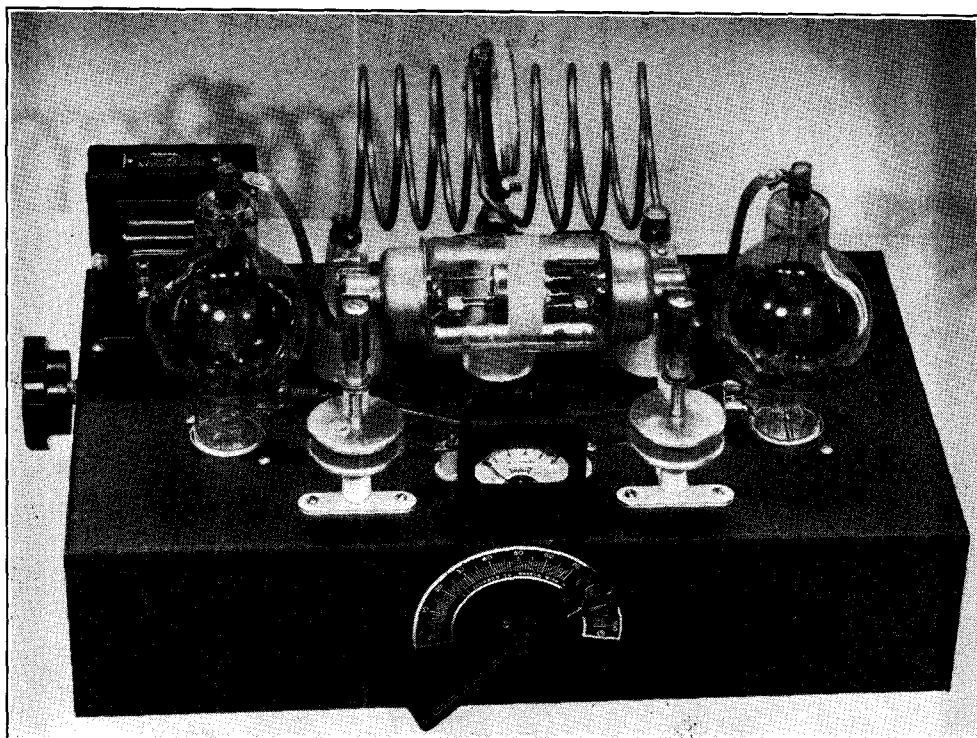

The "Accordion Coil" Amplifier

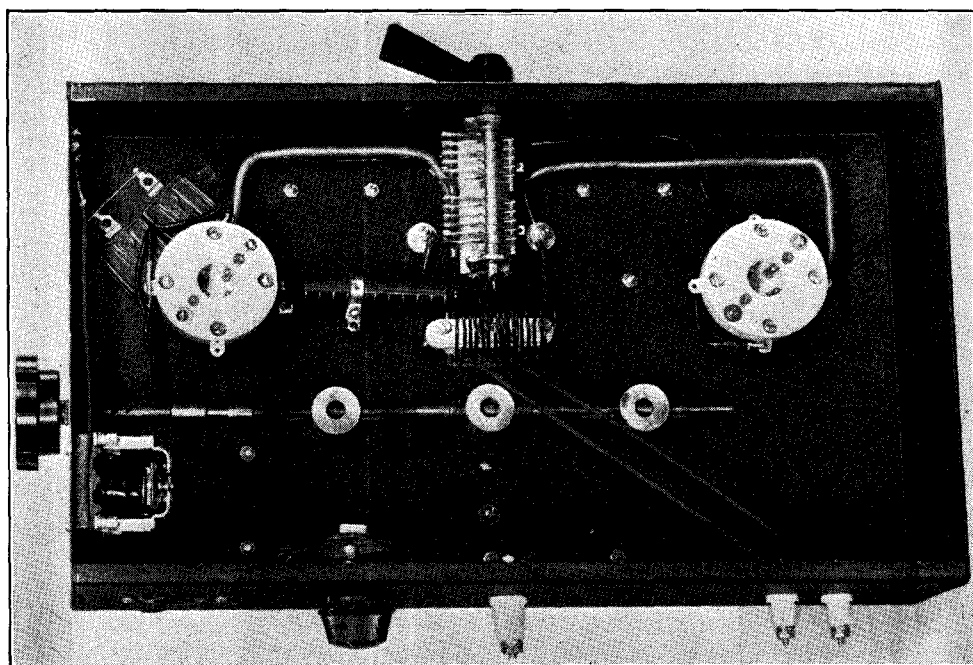



Figure 4.
400-WATT PUSH-PULL AMPLIFIER.

Although 35-TG's are used in this amplifier, the design is applicable to many other tubes of approximately equivalent power rating, provided allowance is made for a different location of the grid terminal and different grid-to-plate capacitances in some cases. The terminals at the rear are for plate, filament and bias supply connections.

FIGURES 2 AND 3
(SEE OPPOSITE PAGE)

Figure 2.
"ACCORDION COIL" HIGH POWER AMPLIFIER.

This high power 10- and 20-meter amplifier utilizes a fixed vacuum tank condenser and variable inductance coil in the plate circuit. The control on the front of the chassis operates the grid condenser. The knob on the right side of the chassis varies the spacing of the two outside cone insulators supporting the semi-rigid plug-in coils. A filament transformer may be seen to the left rear, a filament voltmeter between the two neutralizing condensers just in front of the plug-in vacuum condenser.

Figure 3.
UNDER-CHASSIS VIEW OF THE "ACCORDION COIL" AMPLIFIER.

The mechanism for providing adjustable spacing of the coil supports may be seen in this view. The operation is explained in the text. Next to the coil tuning knob may be seen an overload relay, to protect the tubes in the event of excitation failure. The rheostat on the back of the chassis is in series with the primary of the filament transformer.

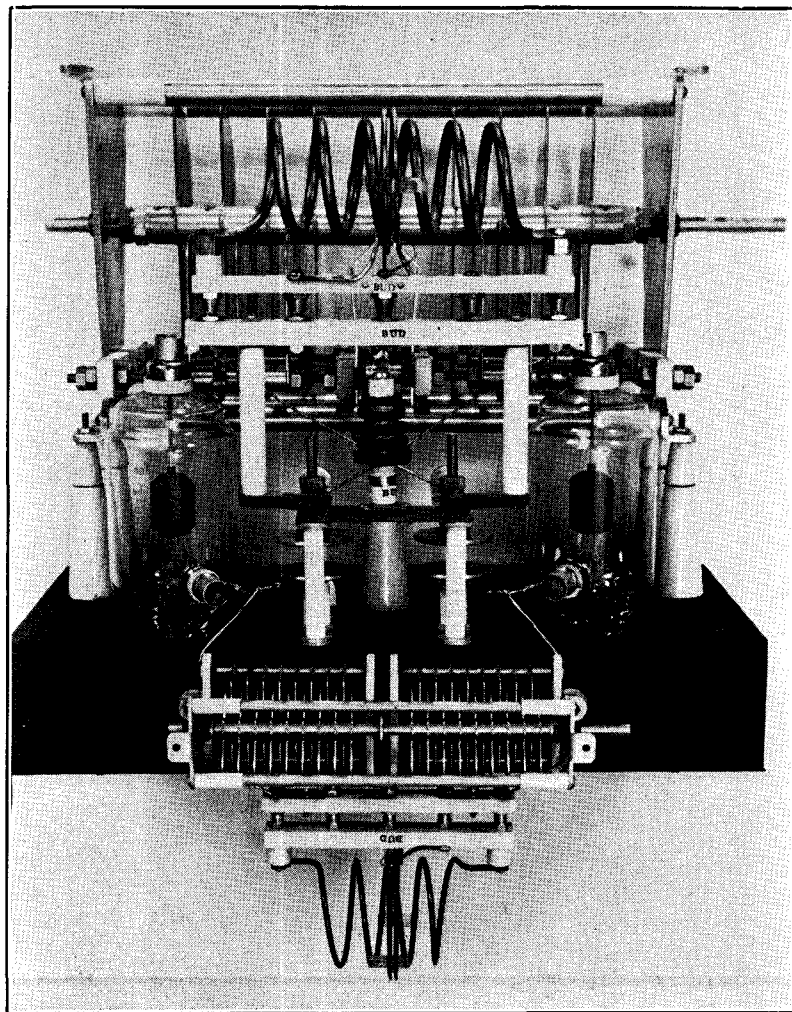

Figure 5.

1-KW. AMPLIFIER OF UNUSUAL DESIGN.

This "skeletonized" push-pull TW-150 amplifier is capable of handling an input of 1 kilowatt, with a plate efficiency of between 75 and 80 per cent. The amplifier is intended to be mounted behind a 19-inch rack panel with the tuning controls being connected to the grid and plate condensers by means of insulated couplings. Note how the r.f. leads are kept to extremely short lengths, for an amplifier of this size, through the use of the unconventional chassis arrangement.

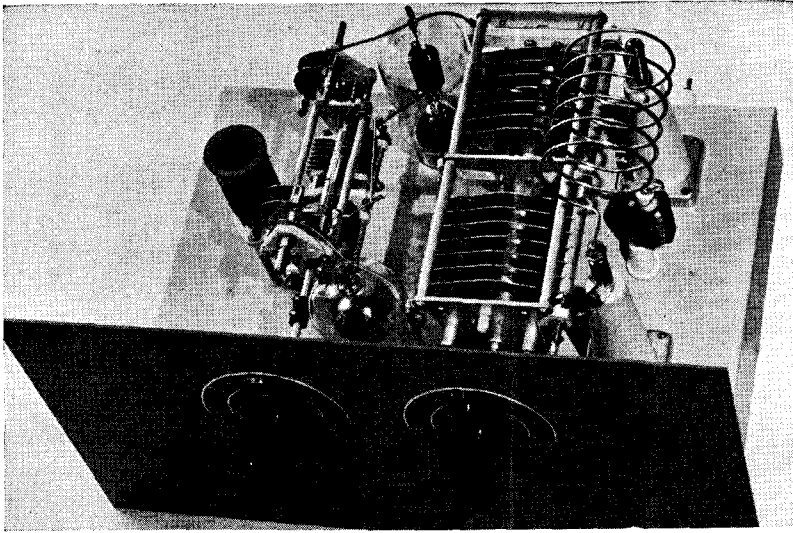

Figure 6.

PANEL AND CHASSIS CONSTRUCTION OF HIGH POWER AMPLIFIER.

This high powered amplifier will take a full kilowatt input on c.w. if 75 watts of excitation is available. High efficiency operation is required, as otherwise the plate dissipation rating of the tubes will be exceeded at 1 kw. input. The HK254's are fed 2500 volts and loaded to 400 ma. The physical layout illustrated permits an average r.f. lead length of slightly over 1 inch; no lead is over $2\frac{1}{2}$ inches.

meters sometimes a fixed capacitance is used in conjunction with a variable inductance to replace the more common type of plate tank consisting of a fixed inductance and variable capacitance. This is permissible in the circuit of figure 1 so long as the fixed tank condenser is symmetrical. It is not advisable to substitute a single-section variable condenser of twice the spacing and half the per-section capacity for C_2 because it would upset the symmetry of the circuit; the rotor (frame) consists of so much more metal than the stator that there would be considerable unbalance with this type of condenser.

The push-pull amplifiers illustrated are designed for link coupling from the exciter or driver. This provides the most efficient energy transfer on the higher-frequency bands.

The maximum allowable plate voltage, plate current and grid current for the various tubes is given in chapter 10.

The pictorial illustrations are merely for the purpose of furnishing ideas for possible mechanical layouts. All of the arrangements shown permit very short r.f. leads, but it is not necessary to use the particular tubes specified in each case for the particular physical layout illustrated. For instance, with very slight modifications in the amplifier, 35T's, HK54's, 808's, or T55's could be used

in the amplifier pictured in figure 2 by providing the proper grid leak and filament transformer.

The filament transformer may be placed right at the amplifier, or it may be located in the power supply if allowance is made for the voltage drop in the connecting leads due to the filament current. In either case the voltage should be the correct value specified by the tube manufacturer at the *tube sockets*.

Circuits which use variable inductances and fixed air or vacuum tank condensers are sometimes used for 10- and 20-meter operation. An example of this type of amplifier is shown in figures 2 and 3. In the under-chassis view the mechanism for moving the standoff insulators at each of the coils toward and away from each other may be seen. The bottoms of the particular insulators shown are threaded and a short stud screwed into the bottom of each of the outer ones runs through a $\frac{1}{4}$ -by-2-inch slot in the chassis and into a cylindrical brass block below the chassis. The center insulator is firmly fastened to the chassis. Each of the outer brass blocks has a $\frac{1}{4}$ -inch threaded hole running through it diametrically. Right-hand threads are used in one block and left-hand threads in the other. The center block has a smooth $\frac{1}{4}$ -inch hole and acts simply as a support bearing.

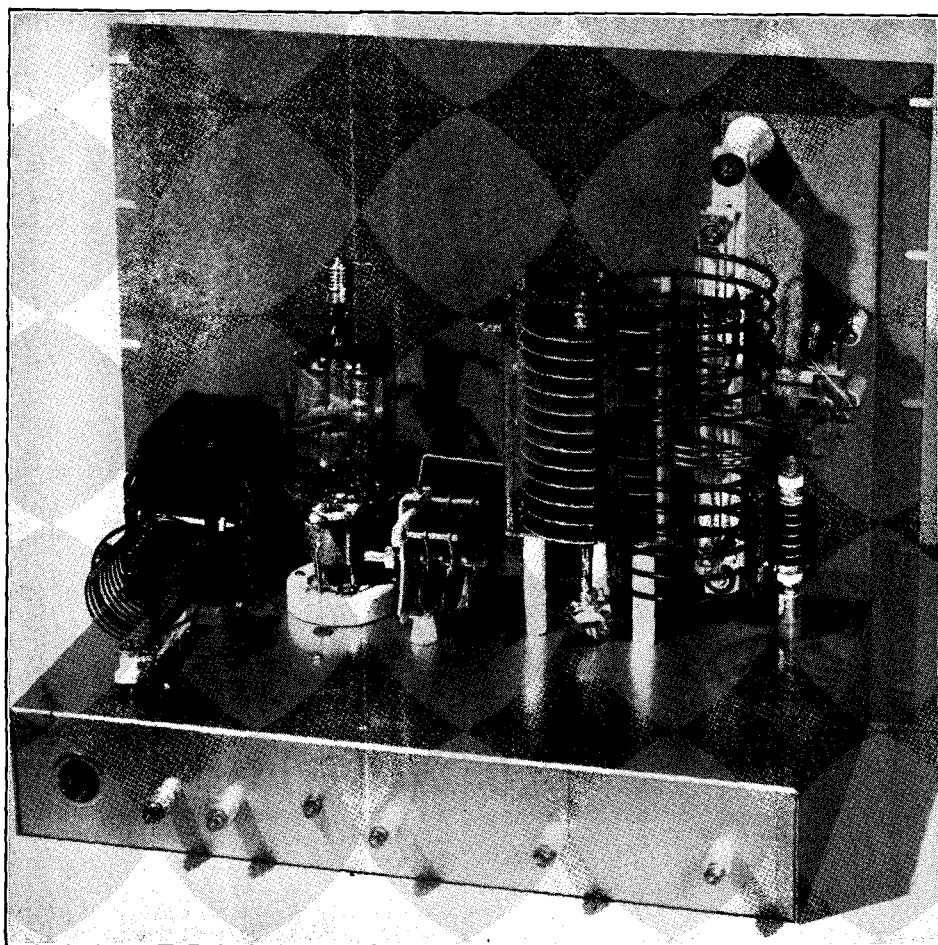

Figure 7.
900-WATT SINGLE ENDED 152-T AMPLIFIER.

Mounting the plate tank circuit vertically, with the neutralizing condenser between the tube and tank circuit, aids in preserving circuit balance in the single ended plate neutralized stage. The filament transformer is located on the chassis.

To move the end insulators back and forth in their slots a piece of brass rod is threaded with a right-hand thread at one end, a left-hand thread at the other, and left unthreaded at the center. When this rod is run through the brass blocks after a collar is put on each side of the center block to prevent end-play (see figure 3), revolving the rod will cause the end insulators to move toward and away from each other, thus changing the length and turn spacing of the coil and altering its inductance. The threaded rod is connected to the knob at the side of the chassis by means of

a short length of additional shafting and a shaft coupling.

To provide a fixed capacity across the tank coil, fixed vacuum condensers are used. These condensers are arranged to plug into fuse clips mounted on the neutralizing condensers. The coils also are arranged to be plugged in for band change. 1/16-inch copper tubing is used for the coils on the 10- and 20-meter bands. It is not practical to use this type of variable inductance on lower frequencies as the coils would not be sufficiently rigid and self-supporting. A 6- μ fd. fixed vacuum

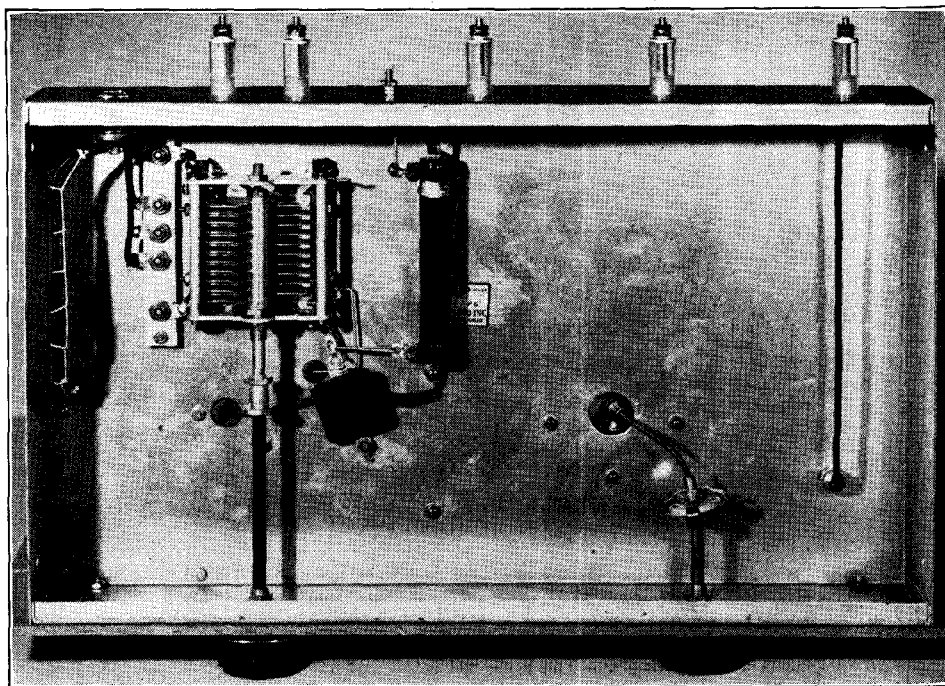

Figure 8.

UNDER-CHASSIS VIEW OF THE SINGLE ENDED AMPLIFIER.

The grid condenser and bias resistor are located under the amplifier chassis. Note the flexible shaft which allows the vertically mounted plate condenser to be controlled from the panel.

condenser may be used for 10-meter phone and 20-meter c.w. work. For 20-meter phone use, a 12- μ fd. condenser should be substituted.

Single-Ended Amplifiers

Although it is usually preferable, both from a standpoint of efficiency and tube cost, to use a push-pull amplifier for medium and high power transmitters, some circumstances, such as the availability of a large tube or desire to couple an extremely unbalanced load to the amplifier, often make it advisable to use a single-ended output stage.

The 152-T amplifier illustrated in figures 7 and 8 and diagrammed in figure 9 is typical of single-ended amplifier circuits. The circuit shown is also applicable to other tubes having a relatively low output capacity. Where the tube's output capacity is high, however, special circuit arrangements are necessary to assure correct neutralization, as explained in *Chapter Seven*.

For a single-ended amplifier it is necessary

that the rotor of the plate tank condenser have an r.f. return to ground. This may be done either by grounding the rotor of the condenser directly or grounding it through a by-pass condenser. If it is grounded directly, the condenser must have somewhat more spacing because both d.c. and r.f. are impressed across the condenser. If it is bypassed to ground through a high-voltage mica condenser of .002- μ fd. to .004- μ fd. capacity, as shown in the diagram, there will no longer be impressed, under steady carrier conditions, anything between the condenser plates except r.f. voltage. However, due to the "lag" in the condenser, transient peaks will be impressed across the variable condenser during plate modulation or primary keying of the stage. Hence, to remove all voltage from the variable condenser except the r.f. voltage across the coil, the rotor of the condenser should be connected through a fairly high resistance to the positive high voltage lead at the power supply end of the plate r.f. choke, as previously described. There can then be no a.f., d.c., or transient voltage impressed across the con-

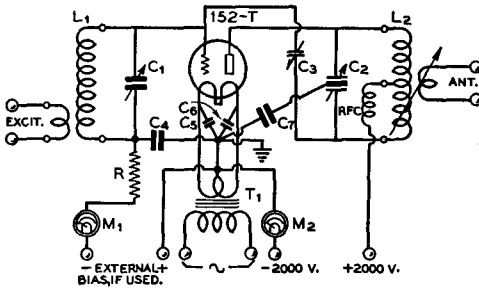

Figure 9.

WIRING DIAGRAM OF TYPICAL SINGLE ENDED AMPLIFIER.

This diagram is for the amplifier illustrated in figures 7 and 8. The tank condenser illustrated is for 10, 20 and 40 meter operation only. The 152-T has two separate sets of filament connections brought out to the socket. These may be connected in series and operated from a 10-volt transformer, as shown in the diagram, or they may be connected in parallel and supplied from a 5-volt transformer.

- C₁—100- μ fd., .070" spacing
- C₂—50- μ fd. per section, .171" spacing
- C₃—9- μ fd., .238" spacing
- C₄, C₅, C₆—0.002- μ fd. 1000-volt mica
- C₇—0.002- μ fd. 5000-volt mica
- R—7000 ohms, 50 watts. If fixed cutoff bias is used (250 v.) this resistor may be reduced to 3000 ohms, 20 watts
- L₁—"100-Watt" manufactured coil
- L₂—"1 Kw." manufactured coil with swinging link mounting
- RFC—2.5 mhy., 500 ma.
- T₁—10 volts, 7 amp. (if filaments are connected in parallel T₁ may be 5 volts, 14 amp.)
- M₁—0-100 ma.
- M₂—0-500 ma.

denser sections because both the rotor and the stator sections are at the same potential except with respect to r.f. voltage across the coil. If the stage is *grid* modulated or if the transmitter is keyed in a low level stage so that plate voltage appears on the tank at all times, then there is no point in connecting the rotor of the condenser to positive high voltage; simply by-passing it to ground with a high voltage condenser will be sufficient.

If a tube has a plate-filament capacity of more than approximately 2 μ fd., it is desirable to connect across the section of the tuning condenser to which the neutralizing condenser is connected a capacitance exactly equal to the plate-filament capacity of the tube. The circuit will then be balanced regardless of the setting of the plate tank condenser, and neutralization will hold for all bands when once set for one of the higher frequency bands. In the 152-T amplifier a small amount of capacity between the neutralizing end of the tank circuit and ground is obtained by mounting the tank condenser and coil vertically, the capacity between the bottom end of the tank circuit and the grounded chassis being approximately equal to the tube's plate-to filament capacity. Beside providing this additional capacity, the vertically-mounted tank circuit also aids in keeping both the plate and neutralizing leads to a minimum length.

As is explained in chapter 7, it is desirable to use a somewhat higher C to L ratio in the plate tank of a single ended amplifier than for a push pull amplifier running at the same plate voltage and plate current.

CHAPTER FOURTEEN

Speech Equipment and Modulators

This chapter deals with the design, construction, and operation of speech amplifiers and modulators and with arrangements such as automatic modulation control circuits which are normally a portion of the modulation equipment.

The audio equipment required in a phone transmitter will vary widely with different types of microphones, different modulation systems, and different amounts of power to be modulated. Since it would be virtually impossible to show designs that would be suited to any type of application, a number of good designs of conventional type will be shown to indicate the method of approach to the problem. These particular designs should more or less completely solve the speech amplifier problem in 75 per cent of the usual amateur transmitter installations. For those special cases where the designs shown are not completely suitable, small variations in the necessary respects will almost surely adapt the designs to individual needs.

The amplifiers and modulators shown have been thoroughly proven in actual use in amateur stations. Consequently, if these designs are followed exactly, no trouble will be experienced either in getting them to work or in their subsequent application to the job at hand. However, when making alterations in the designs to adapt the equipment to slightly different applications, due caution and forethought should be used in making the changes.

Hum Difficulties. It is more than likely that inductive hum pickup will be the problem most frequently encountered both in making alterations in amplifier design and in installing the speech equipment in the operating room or in the transmitter. The proximity of power supply equipment to the audio transformers or to the low-level grid leads should always be taken into consideration.

Any chokes or transformers in the low-level audio stages should be mounted as far as possible from power transformers and input filter chokes, which have relatively large surrounding a.c. fields. The audio transformers and coupling chokes can be properly oriented on the chassis before the holes are drilled for their mounting. A pair of headphones should be connected across the winding of each audio transformer or choke; 110-volts a.c. is then supplied to the primaries of all power transformers, and the audio transformer or choke is then rotated to determine the center of the hum "null." It should be bolted to the chassis in this position even if it detracts from the neatness of the amplifier.

Some manufacturers offer special hum-bucking transformers for use in low-level audio stages; the transformers are so wound that they need not be specially oriented for minimum hum pickup.

Especial care need not be taken with high-level audio transformers such as class-B input and output transformers if they are well-shielded and are not mounted too close to any power transformers.

Use of resistance coupling in the low-level audio stages of a speech amplifier makes it unnecessary to take precautions against inductive hum pickup, but grid and plate leads should be shielded to prevent electrostatic pickup, resulting in a.f. feedback and hum pickup.

A separate ground lead from the speech amplifier to an external ground is strongly advisable when the speech amplifier is not integral with the rest of the transmitter. With relay construction, in which the rack frame constitutes a common ground for both r.f. and audio units, a heavy copper bus run as direct as possible to a good external ground will suffice.

Amplifier Input Circuits. Various types

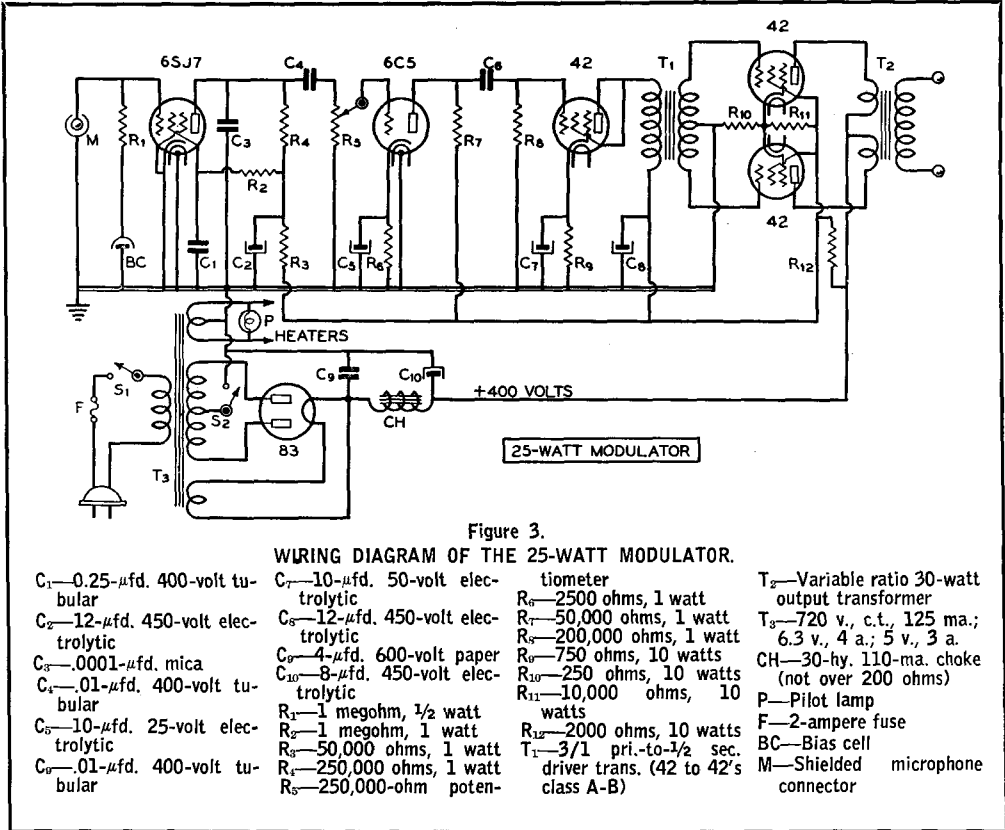

transmitter, a modulator with an output in the vicinity of 25 watts is usually required. Such a unit is pictured in figures 1 and 2, the schematic wiring diagram appearing in figure 3. This modulator is simple and inexpensive to construct, and will plate modulate inputs of 40 to 60 watts on voice with excellent quality; the maximum output of the modulator with voice frequency input and tolerable harmonic distortion is about 25 watts.

While the unit can be used to drive a class-B modulator or to grid modulate a high powered grid modulated transmitter simply by tying a 15,000-ohm 10-watt resistor between the plates of the push-pull 42's, the unit is not recommended for such work, as it does not work as well into a variable load as do some of the other units described in this chapter. In other words, the unit works best when the output feeds into a constant load such as when it is used to plate modulate a low powered transmitter.

Tube Lineup. The first stage of the amplifier, a pentode-connected 6SJ7, is designed to operate from a crystal or other high impedance microphone. The input plug is of

the shielded type, allowing a firm screw-on connection to the grounded side of the microphone cable.

A 6C5 in a conventional resistance coupled circuit amplifies the output of the 6SJ7 sufficiently to drive the triode-connected 42. The latter has more than sufficient output to swing the grids of the push-pull modulators with low distortion.

The values of the coupling condensers C₄ and C₈ were chosen with respect to R₅ and R₈ so that the gain will be attenuated in the extreme bass register (below 150 cycles). The advantages of bass suppression for voice transmission were covered in chapter *Eight*.

42's were chosen for use in the last two stages because they are inexpensive considering their power capabilities; also they will give service under a moderate overload.

The output tubes are operated with semi-stabilized cathode bias. The resistor R₁₁ stabilizes the screen voltage, the grid bias, and at the same time acts as a bleeder for the power supply.

Operation. The variable ratio output transformer makes the modulator adaptable



Figure 4.
TOP VIEW OF THE 60-WATT
T-21 MODULATOR.

The power supply components are lined up along the rear half of the chassis, starting with the bias rectifier and ending with the oversize power transformer on the right rear. The audio frequency stages progress from left to right along the front of the chassis ending up with the multiple-match output transformer on the right end.

to most any transmitter. The taps should be connected so that a load of approximately 10,000 ohms, plate to plate, is placed on the 42's when the modulated stage is drawing normal plate current. The correct method of connecting the transformer taps for any particular installation can be determined quite easily by referring to the impedance ratio chart supplied with the particular make of transformer used.

As an example, if the modulated stage draws 100 ma. at 500 volts (such as a single 809) the load on the secondary of the modulation transformer will be 5000 ohms. Look up on the transformer chart the closest combination which reflects a 10,000-ohm plate-to-plate load on the primary when a 5000-ohm load is placed across the secondary of the transformer.

A 60-Watt T-21 Modulator Incorporating A.M.C.

The modulator illustrated in figure 4 is designed primarily for use as a complete speech amplifier and modulator to operate from a diaphragm-type crystal microphone and to plate modulate about 150 watts input to a class C amplifier. It could, of course, also be used as a cathode modulator for 400 to 500 watts input to the stage; or, with about 20 db of feedback to the grids of the 6J5 drivers, it could be used as a high-level driver for a high-power class-B stage.

A. M. C. Provision. Automatic modulation control has been incorporated into the design of the first stage of the amplifier. If it is desired to use the a.m.c. provision, and

it is highly recommended that it be used, the a.m.c. rectifier may be coupled into the terminal marked "a.m.c. input." If it is not desired to use a.m.c. the terminal may be left open or grounded, as desired. Incidentally, there must be a biasing system incorporated into the a.m.c. rectifier, as shown in the one at the end of this chapter; some of the earlier a.m.c. systems had the biasing system incorporated into the speech amplifier and hence did not need any bias on the a.m.c. rectifier. If an unbiased rectifier is used with this arrangement, the a.m.c. action will not come into effect until 100 per cent modulation is reached.

A New Phase-Inverter Circuit. The 6J5 phase inverter operates in a new-type circuit which is quite simple and yet which gives a reasonable amount of gain. On first glance it might appear that the 6J5 operates in the conventional "hot cathode" circuit which has been used for some years with reasonable success. But while the old circuit gave practically no gain in voltage in the phase inverter, by the changing of a few values and the addition of a resistor and a condenser the voltage gain of the circuit has been increased to approximately 7 per side or a total gain of about 14. Quite a worthwhile improvement for the addition of only one resistor and a condenser.

The operation of the circuit is simple enough and should be apparent by inspection of the diagram. In the conventional arrangement, with C_7 and R_6 not in the circuit, when a voltage is impressed upon the grid of the 6J5 half the voltage output of the tube appears across the cathode return resistor R_{10} . This voltage is fed back 180° out of phase

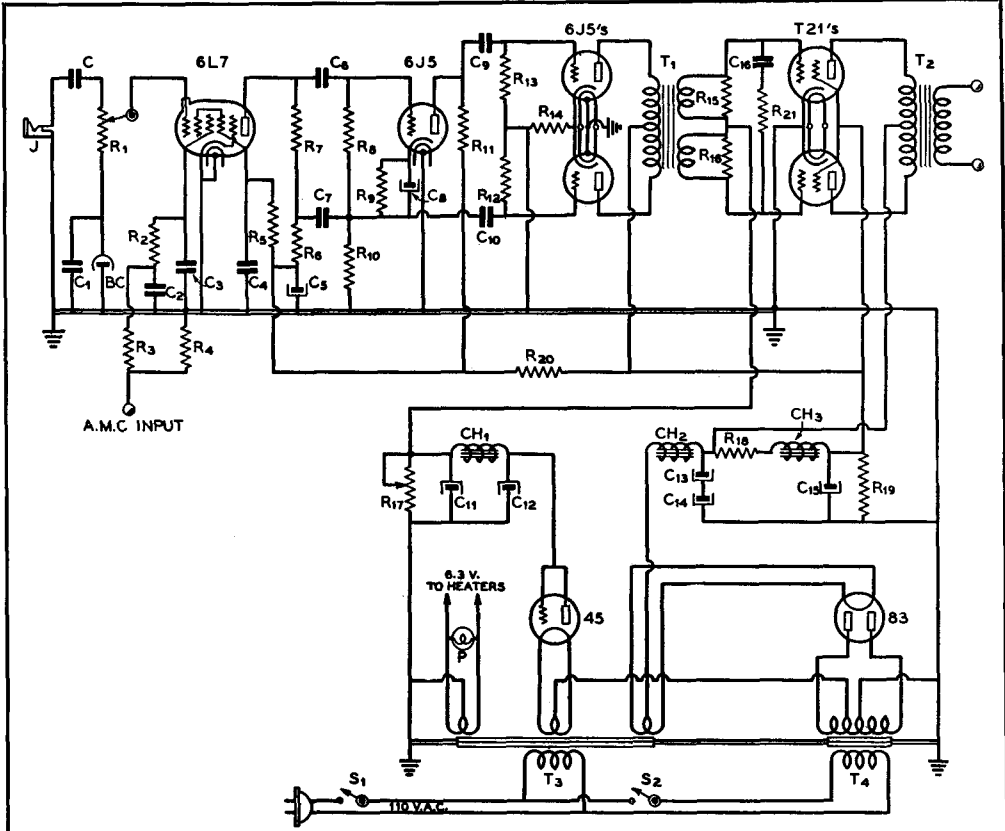

Figure 5.

WIRING DIAGRAM OF THE 60-WATT T-21 MODULATOR.

- | | | | |
|---|---|--|--|
| C ₁ , C ₂ —0.1- μ fd. 400-volt tubular | C ₁₃ , C ₁₄ , C ₁₅ —8- μ fd. 450-volt elect. | R ₁₁ —50,000 ohms, 1/2 watt | T ₁ — 5:1 driver-to-6L6 trans. |
| C ₃ —0.005- μ fd. 400-volt tubular | C ₁₀ —0.005- μ fd. mica | R ₁₂ , R ₁₃ —250,000 ohms, 1/2 watt | T ₂ —Multi-match output trans. |
| C ₄ —0.5- μ fd. 400-volt tubular | R ₁ —1.0-megohm potentiometer. | R ₁₄ —600 ohms, 1 watt | T ₃ —2.5 v., 3.5 a.; 5 v., 3 a.; 6.3 v., 3 a. filament trans. |
| C ₅ —0.1- μ fd. 400-volt tubular | R ₂ —1.0 megohm, 1/2 watt | R ₁₅ , R ₁₆ —10,000 ohms, 1 1/2 watts | T ₄ —1030 v. c.t., 250 ma.; bias tap at 30 volts |
| C ₆ —8- μ fd. 450-volt elect. | R ₃ —100,000 ohms, 1/2 watt | R ₁₇ —1500-ohm 10-watt slider or 1000-ohm 10-watt fixed | CH ₁ — 7.2-hy., 120-ma. choke |
| C ₇ —0.1- μ fd. 400-volt tubular | R ₄ —500,000 ohms, 1/2 watt | R ₁₈ —2000 ohms, 10 watts | CH ₂ — 13-hy., 250-ma. choke |
| C ₈ —10- μ fd. 25-volt elect. | R ₅ —1.0 megohm, 1/2 watt | R ₁₉ —25,000 ohms, 20 watts | CH ₃ —15-hy., 85 ma. choke |
| C ₉ , C ₁₀ —0.1- μ fd. 400-volt tubular | R ₆ —100,000 ohms, 1/2 watt | R ₂₀ —5000 ohms, 10 watts | S ₁ —A.c. line switch |
| C ₁₁ , C ₁₂ —16- μ fd. 100-volt elect. | R ₇ , R ₈ —250,000 ohms, 1/2 watt | R ₂₁ —5000 ohms, 1 1/2 watts | S ₂ —Plate on-off switch |
| | R ₉ —2500 ohms, 1/2 watt | | |
| | R ₁₀ —100,000 ohms, 1/2 watt | | |

with the incoming voltage and in series with it. The resulting 50 per cent degenerative feedback reduces the gain of the stage to just more than one. But by isolating the cathode feedback voltage from the exciting voltage which appears across R₇, the plate circuit of the 6L7, the degenerative feedback is greatly reduced and the stage attains almost normal

gain—in addition to its function as a phase inverter.

One consideration in the design is the shunt resistance of R₁₀ and R₈ as compared to the resistance of R₁₁ (R₁₀ and R₈ are effectively shunted as far as audio frequencies are concerned by the effects of condensers C₇ and C₅). The shunt effect of the first two should

be equal to R_{11} . The most satisfactory way of obtaining this is to make R_{10} and R_6 each twice the value of R_{11} . This allows an equal audio voltage division between the plate and cathode circuits of the inverter tube. The plate impedance of the 6L7 is so high (approximately 0.8 megohm) as not to disturb the balance of the circuit materially.

P. P. 6J5 Drivers. The driver stage for the T21's is perfectly conventional and consists of a pair of 6J5's operating into a 5:1 driver-to-6L6 class AB_2 transformer. The swamping resistors R_{15} and R_{16} across the secondary of the driver transformer serve to improve the audio regulation. T-21's are used as the final modulator tubes with 400 volts on their plates and operating with fixed bias.

Separate Bias Supply. The bias supply uses a 45 with the grid and plate strapped together operating from the 30-volt tap on the power transformer. With the particular components that were used in the laboratory model of this modulator, when R_{17} was made a 1000-ohm 10-watt resistor the bias voltage was the proper value on the T-21's. However, to allow for variations in tubes and equip-

ment it was felt best to specify a 1500-ohm adjustable resistor in this position. In any case the shorting tap on the resistor will be very near to 1000 ohms.

The resistor-capacity network from grid to grid on the T-21's, C_{16} and R_{21} , was placed in the circuit to improve the waveform of the output at speech frequencies. Through the use of comparatively low value of coupling condensers from stage to stage within the amplifier the frequency response of the amplifier drops quite sharply below 150 cycles. This reduces the difficulties resulting from hum pickup and allows a higher relative modulation percentage to be obtained on the voice frequencies above 150 cycles, those that contribute most to the intelligibility.

The primary and secondary of the multi-match output transformer should be strapped so as to present a plate-to-plate load of 4000 ohms to the T-21 tubes with the value of secondary load into which the tubes are working. Maximum output and maximum modulating ability with minimum harmonic distortion will be obtained from the amplifier under these operating conditions.

Figure 6.
UNDER-CHASSIS VIEW OF THE T-21 MODULATOR.

All power supply components are arranged along the rear side of the chassis and all audio components along the front. The single interconnecting cable between the two halves of the amplifier tends to minimize electrostatic coupling between them and hence to reduce hum pickup. However, to minimize electrostatic pickup from external sources it has been found desirable to place a metal cover on the bottom of the chassis. The chassis should be connected to external ground by an independent connection.

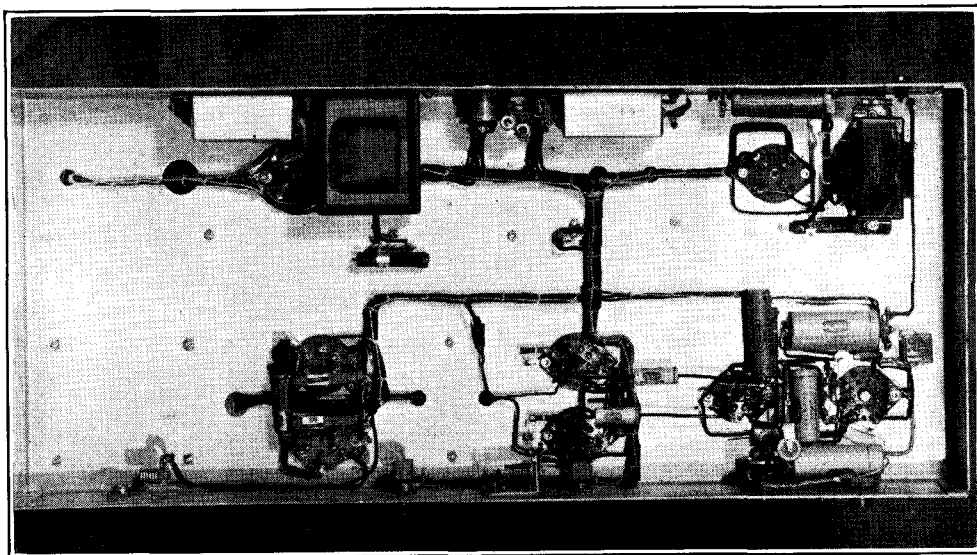

A 6.5-Watt Amplifier with Degenerative Feedback.

Figure 7 illustrates a simple 6.5-watt amplifier specifically designed to operate from a crystal microphone and to be used as a grid modulator for a medium to high powered amplifier. A single-ended 6L6 is used as the output tube with degenerative feedback from its plate back to its grid circuit. The use of degenerative feedback greatly lowers the plate impedance of the 6L6 and considerably reduces any harmonic distortion that might be introduced as a result of the operation of a single-ended beam tetrode stage. The reduction in the plate impedance of the 6L6 by feedback improves the regulation of the output voltage with respect to such changes in loading as are had when grid modulating an amplifier.

The Feedback Circuit. The addition of the single resistor R_{11} from the plate of the 6L6 back to the plate of the 6SJ7 amplifier stage reduced the harmonic distortion, measured from the input of the 6SJ7 to the output of the amplifier, from approximately 11 per cent at 6.5 watts output to less than 3 per cent at 7 watts output. However, the amplifier is only rated at 6.5 watts output because of the power taken by the shunting resistor R_{13} which goes from the bottom end of the output transformer to ground. The addition of the resistor for the shunt feedback circuit reduces the gain of the amplifier only a small percentage; there is ample gain to give full output when using a diaphragm-type crystal microphone on the input.

The power supply uses an input resistor instead of the more common input condenser

or choke. The resistor serves to limit the voltage of the power supply to the proper value both because of its action as a resistance and because it acts as an input impedance ahead of the first condenser. It also contributes to the filtering action.

The Output Circuit. The shunt resistor R_{13} serves a triple purpose. In the first place it acts as a load upon the output of the 6L6 to stabilize its output with respect to variations in load. Second, it acts as a bleeder upon the power supply to reduce the possibility of blowing the filter condensers in the interval between the heating up of the filament of the 5Z3 and the coming to operating temperature of the cathode of the 6L6. Third, its drain through the secondary of the output transformer opposes that of the 6L6 and tends to cancel the saturating action of the plate current of the 6L6 upon the core of the transformer.

The output transformer T_1 is a unit designed to be used as a driver transformer between push-pull 2A3's and the grids of a pair of 801's in class B. However, by using it in the amplifier as shown it is possible to obtain a selection of four different impedance ratios from the plate of the 6L6 to the grid of the tube being modulated. If the 6L6 is fed into the side of the transformer originally meant for the 2A3's the use of the full secondary will give a ratio of 2.35 to 1 step up; the use of half of the secondary will give about 1.2 to 1 step up. Then if the 6L6 is operated into the side designed for the 801's, the use of the total secondary will give a ratio of 1.7 to 1 step up, the use of half of the secondary will give a ratio of 1 to 0.85 step down. This latter ratio is the one most likely to be used

Figure 7.
FRONT VIEW OF THE 6.5-
WATT AMPLIFIER.

The three audio tubes, the 6J5 first stage, the 6SJ7 second, and the 6L6 power amplifier are lined up along the left end of the chassis. The output transformer is alongside the 6L6; the other components are those associated with the power supply. The jack for the crystal microphone and the volume control are on the front drop of the chassis.

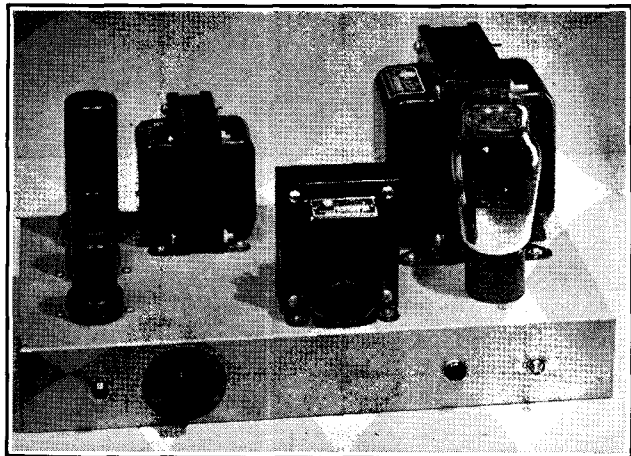

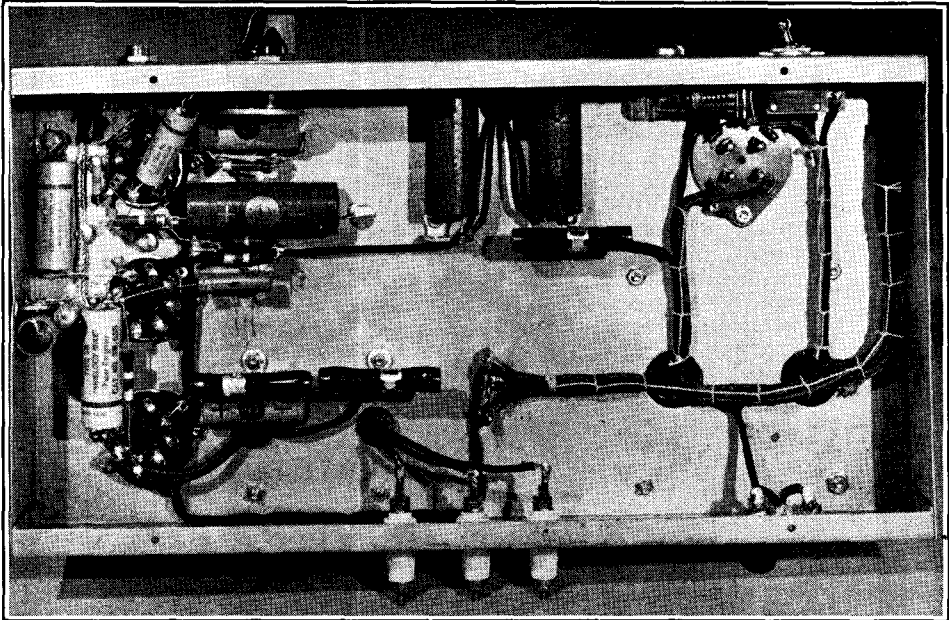
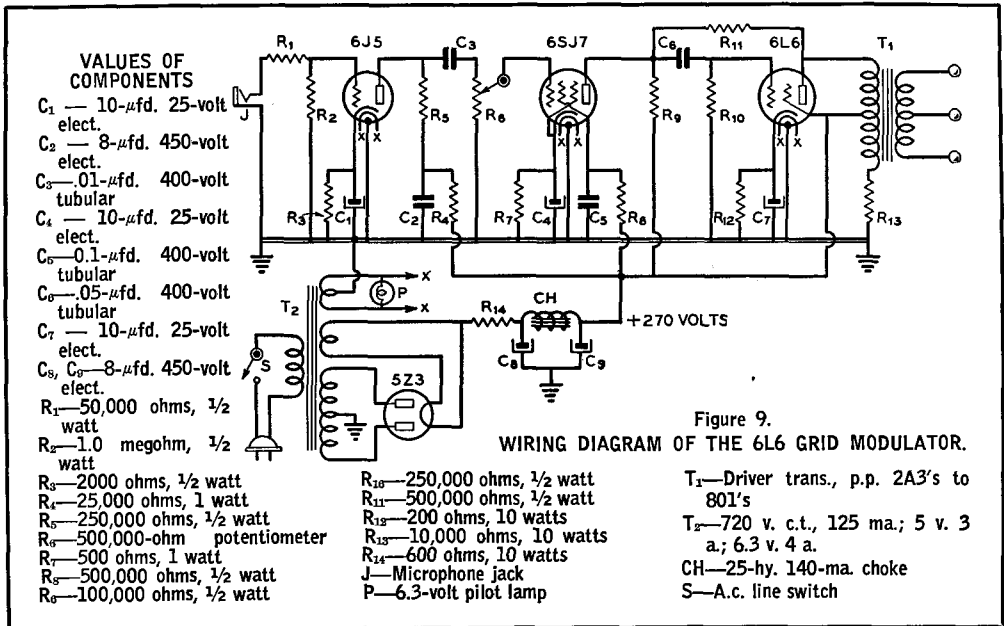

Figure 8.

UNDER-CHASSIS VIEW OF THE 6L6 AMPLIFIER OR GRID MODULATOR.

Under-chassis layout is comparatively simple and is made to present a neat appearance by cabling all the power supply leads. The three feedthrough insulators on the back drop of the chassis are the three leads from the secondary of the modulation transformer; they can be used either to feed the grid return of the grid modulated stage or they may be used to plate modulate 10 to 15 watts input to a class C stage.



when modulating medium- μ tubes at normal plate voltages. The step-up ratios would be used with medium- μ or low- μ tubes at comparatively high plate voltages and plate inputs up to one kilowatt.

Push-Pull 2A3 Amplifier-Driver

A speech amplifier-driver for a medium powered class B modulator is shown in figures 10 and 11. The amplifier is designed to work out of a diaphragm-type crystal microphone, although any other type of input circuit could be used with equally good results. Alternative input circuits have been shown in *Chapter Eight*.

The first stage utilizes one of the new single-ended metal pentodes, a 6SJ7. The gain control is between its plate circuit and the grid of the 6C5 second stage. The output tubes are a pair of 2A3's operating with a self-bias resistor in their common filament return. Operating in this manner the 2A3's have an undistorted output of approximately 10 watts.

As a Driver. A pair of 2A3's operating in this manner will have ample output to drive most any class-B modulator whose output is 300 watts or less. The driver transformer for coupling the plates of the 2A3's to the grids of the class B stage is not shown since it has been found best to have this transformer at the grids of the driven tubes rather than at the plates of the drivers. The correct transformer step-down ratios for driving almost any class B tube have been set down in tabular form by the various transformer manufacturers. When the driver transformer is purchased one should be obtained which has the proper ratio for the tubes to be used.

Some manufacturers make multiple-ratio transformers which allow a proper match to be obtained for a large number of tubes.

A three-wire shielded cable should be run from the output of the 2A3 tubes to the driver transformer at the grids of the class B tubes. This cable may be made any reasonable length up to 25 or 30 feet. Make sure that the insulation from the three wires to ground is ample to withstand about twice the d.c. voltage on the tubes.

For driving a class B modulator of less than 75 watts output, type 45's may be substituted for the 2A3's with no changes in circuit constants. The 45's are less expensive.

Class B 809 Modulator

Figures 12 and 13 illustrate and show the schematic of a class B modulator using a pair of 809's. This modulator is designed to be driven by the push-pull 2A3 speech amplifier-driver shown above. A pair of 45's also could be used as drivers but the 2A3's will have a reserve of driving power that will make for better quality from the modulator.

Voice Modulation Operation. With the 809's operating at 750 volts plate and 4.5 volts of bias the plate-to-plate load should be 4800 ohms for maximum speech-waveform peak audio output. Under these conditions of operation the instantaneous peak output from the tubes will be about 300 watts which will allow the 809's to modulate an input of 300 watts to the class C amplifier. With 900 volts on the 809's the proper plate-to-plate load resistance is 6200 ohms and the peak output will be approximately 350 watts. If the plate voltage is raised to 1000 and the bias to 8 or 9 volts, the proper plate-to-plate load

Figure 10.
THE 2A3 SPEECH
AMPLIFIER-DRIVER.

The jack for the crystal microphone is mounted on the right drop of the chassis directly alongside the grid lead of the 6SJ7 first speech stage. The low plate impedance of the 2A3's makes this amplifier an ideal driver for any medium power class B modulator.

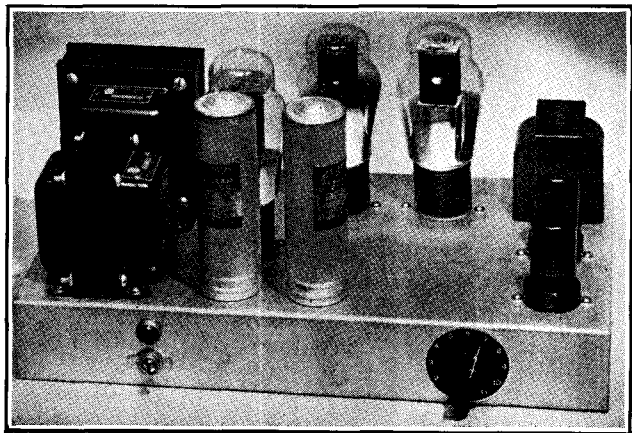

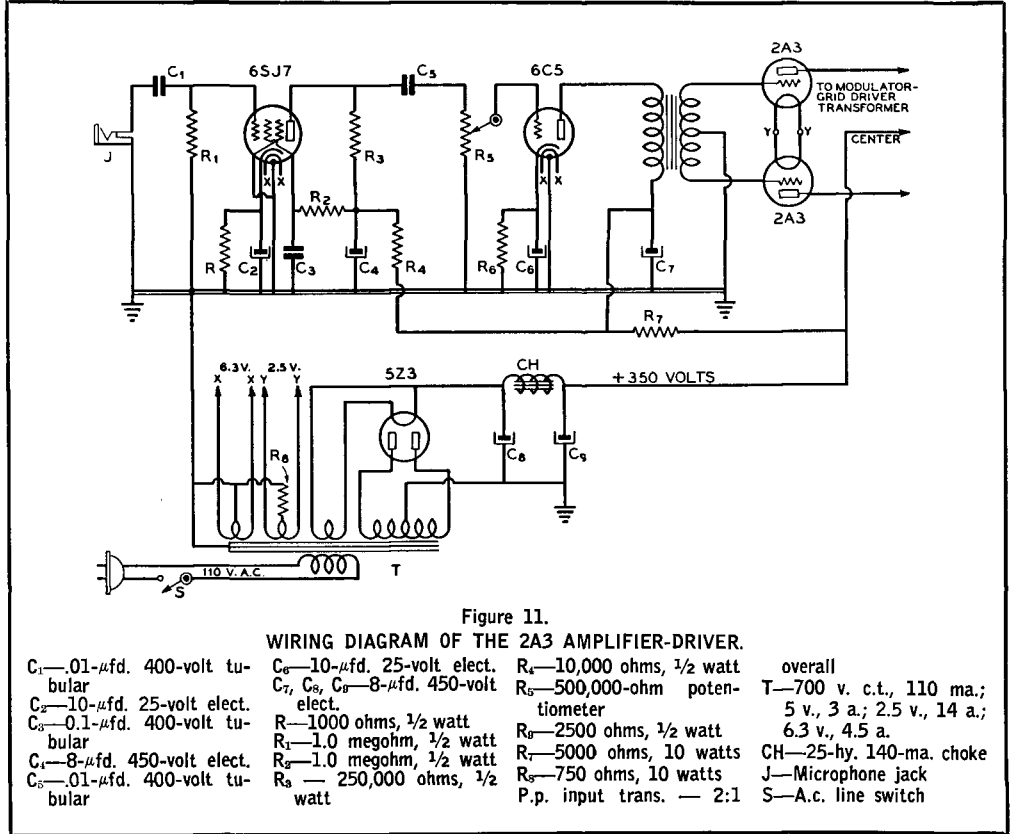

value is 7200 ohms and the tubes will deliver a peak output of 400 watts, allowing them to voice modulate an input of 400 watts to the final stage.

Under all the above conditions of operation full output from the 809's will be obtained when they are driven to an average plate current of approximately 160 ma. as indicated by the milliammeter M in the plate

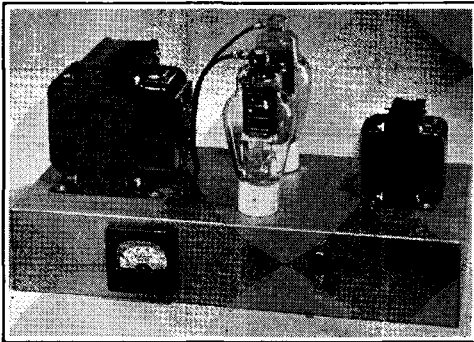

circuit. Testing of the modulator with sine-wave audio as generated by an audio oscillator is not to be recommended except for a very short period of time, just long enough to make the measurement. If continuous modulation with a sine-wave tone is attempted the maximum plate dissipation ratings of the 809's will be exceeded.

The input transformer ratio of total primary to half secondary should be approximately 4.5 to 1 for all conditions of operation.

Sine-Wave Operation. If it is desired to operate the 809's under the sine-wave audio conditions for modulating a smaller input to the class C stage the following conditions will apply: plate voltage, 500; grid bias, 0; plate-to-plate load impedance, 5200 ohms; power output 60 watts (which will modulate an

Figure 12.

CLASS B 809 MODULATOR.

Multiple ratio transformers have been used both in the grid and plate circuits of the modulator to increase its flexibility in matching various driver combinations and in coupling to various values of load impedance.

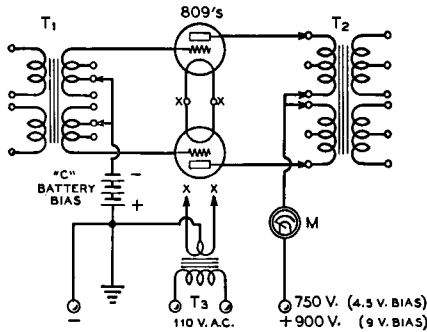

Figure 13.
SCHEMATIC DIAGRAM OF THE 809
MODULATOR.

- T₁—Multiple-ratio input transformer; 4.5:1 step-down ratio usually used
- T₂—Multiple-impedance output transformer
- T₃—6.3-volt 5-ampere filament transformer
- M—0-250 d.c. milliammeter

input of 120 watts to the class C stage); maximum signal plate current, 200 ma. Another set of conditions recommended for somewhat greater power output with sine-wave audio are: plate voltage, 750; grid bias, 4½; plate-to-plate load, 8400 ohms; power output, 100 watts (which will sine-wave mod-

ulate 200 watts input to class C stage); maximum signal plate current, 200 ma. The correct driver transformer step-down ratio for these operating conditions is also 4.5: 1.

Speech-Modulator Unit with TZ-40's for 600 Watts Input

Illustrated in figures 14 and 15 and diagrammed in figure 16 is a complete speech channel capable of plate-modulating an input of between 500 and 600 watts on voice. It incorporates a.m.c., inverse feedback and other desirable modern features.

The combined speech amplifier-class-B modulator, with the associated power supply for the speech amplifier, is built upon one 24"x10"x3" metal chassis. The underside of the chassis is not painted; the plated cadmium finish on this side facilitates the grounding of the various components.

The power supply for the speech stages is mounted along the left hand side of the chassis. Then there are mounted, in a row, the 6J7 first audio stage, the 6L7 a.m.c. amplifier and the 6F6 last audio. Then, in the next row, in front is the multitap driver transformer for the class B stage, then the two 6V6 drivers and, in back, the coupling transformer between the 6F6 and the two 6V6G's.

Figure 14.
FRONT VIEW OF THE TZ-40 SPEECH AMPLIFIER-MODULATOR.
This combined speech amplifier and modulator will fully modulate up to 600 watts on voice. It incorporates inverse feedback, a.m.c., and other features.

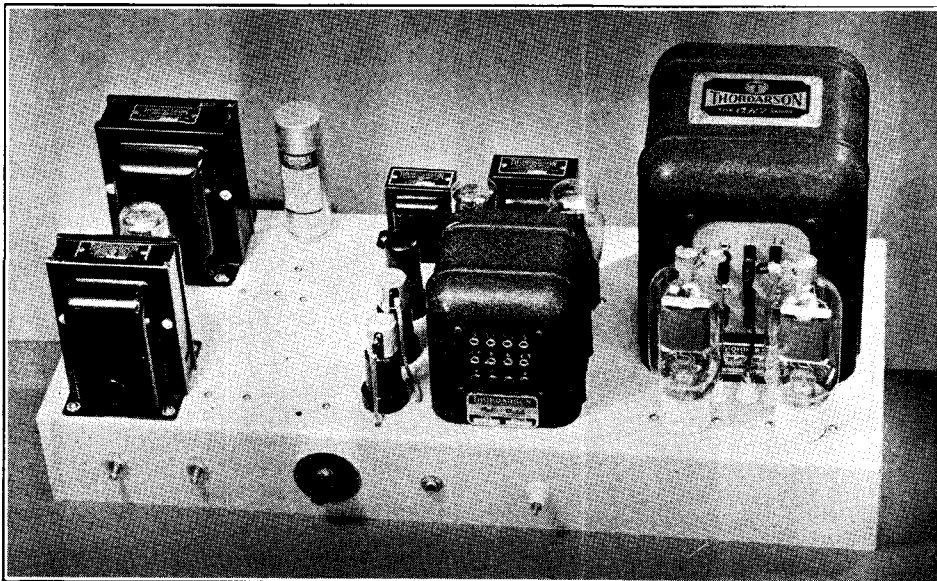

On the right hand end of the chassis are mounted the two TZ40 modulators and their associated class B output transformer.

Looking at the front of the chassis can be seen at the extreme left, the on-off switch for all filaments and for the plate supply for the speech amplifier. The plate supply for the TZ40's is controlled at the transmitter proper. The next switch is the on-off switch for the a.m.c. circuit. Then comes the gain control, the microphone input jack and the binding post for connection to the a.m.c. peak rectifier.

The under-chassis view is practically self-explanatory. At the extreme right end of the chassis is the 7.5-volt filament transformer

for the TZ40's and to the left of the center of the chassis are mounted the resistor plates. Only the upper one can be seen as the two are mounted one above the other.

The speech amplifier uses a 6J7 metal tube connected as a high-gain pentode in the input. The circuit is conventional and the tube is designed to operate from a diaphragm-type crystal microphone. The closed circuit jack on the input of the amplifier is shielded by a small metal can to eliminate any possibility of coupling between the output of the amplifier and the input circuit. Since the large metal spring of the jack is at grid potential, it is desirable to shield it from the output circuit of the 6V6G's and from the a.m.c. lead which runs very close to the jack.

Automatic Modulation Control. The second stage of the amplifier—the a.m.c. stage—utilizes a 6L7 tube. The 500,000-ohm volume control is placed between the plate circuit of the 6J7 and the control grid of the 6L7. It is important that this potentiometer be of the insulated-shaft type since the entire 6L7 circuit operates considerably above ground potential.

The 879 reverse peak rectifier should be connected as follows: the plate of the tube should be connected directly to the a.m.c. binding post on the amplifier, and the filament of the tube should be connected to the lead that goes to the plates of the modulated class C amplifier. The filament should be lighted from a 2.5-volt filament transformer that is adequately insulated for twice the average plate voltage of the modulated amplifier plus 1000 volts. Also, it is often a good idea to remove the negative peak rectifier as far as conveniently possible from both the speech amplifier and the class C final.

Since the injection grid of the 6L7 a.m.c. amplifier is 70 to 90 volts above ground potential (the whole a.m.c. stage is, as mentioned before, at this potential above ground), the 879 peak rectifier will begin to operate when the plate voltage on the class C amplifier becomes less than 70 or 90 volts, whatever the case may be. Then, as the modulator tends to drive the plate voltage lower than this, the gain on the speech amplifier will be reduced as the injector-grid bias on the 6L7 becomes negative. As this negative bias is increased, the signal output of the modulator is reduced. The final result: the output voltage of the modulator is reduced to an amount that will not cut the negative-peak plate voltage on the class C stage to zero; consequently, there is no overmodulation.

The gain on the speech amplifier may be run up to an amount which will permit a

Figure 15.

UNDER-CHASSIS VIEW OF THE TZ-40 MODULATOR.

The use of a resistor terminal plate, under-chassis wiring, and placement of components can be seen.

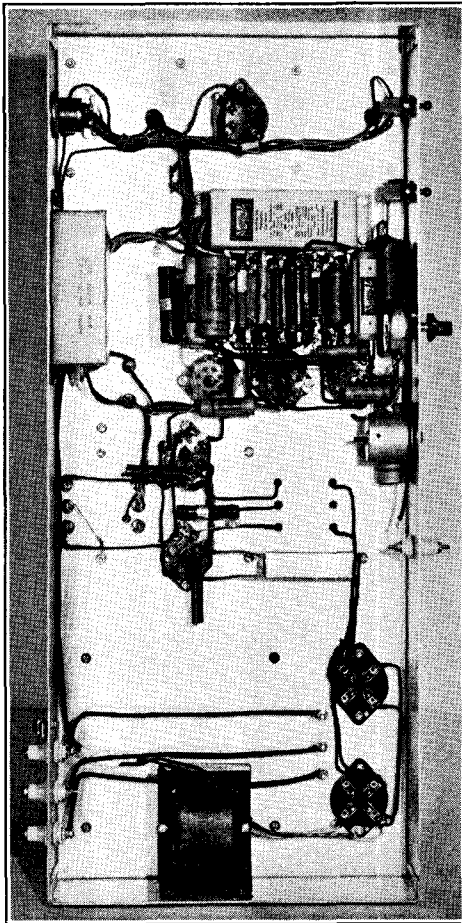

higher average voice level from the transmitter without any chance of overmodulation under any case. When the resulting signal is heard over the air, the transmitter seems to be modulated at a much higher percentage although there is no tendency toward overmodulation splatter or hash.

The 6V6G Drivers. A pair of 6V6's or 6V6G's are used as drivers for the TZ-40's. By using degenerative feedback from the secondary of the driver transformer to the screens of the 6V6's, the plate impedance of these tubes is lowered, thus making them well suited for use as drivers.

Beam tetrodes when connected in the conventional manner are not particularly well-suited as drivers for a class-B stage unless a considerable amount of swamping is used.

The high plate resistance of the tubes in the conventional method of connection causes a large drop in output voltage when any increase in load is placed upon them.

When first placing the amplifier in operation, it is very important that the screens be connected to the proper side of the class B modulation transformer secondary. The only way of finding out which side is the proper one is to connect up the amplifier and try it out. It is best not to have the plate voltage on the TZ40's when this test is made—something may flash over. Should the 6V6G's oscillate, reverse the connections between the screen grid coupling condensers and the class B grids, and the correct phase relation between the screen and plate voltages will be obtained.

Figure 16.
SCHEMATIC DIAGRAM OF THE TZ-40 MODULATOR AND ASSOCIATED A.M.C. SPEECH AMPLIFIER.

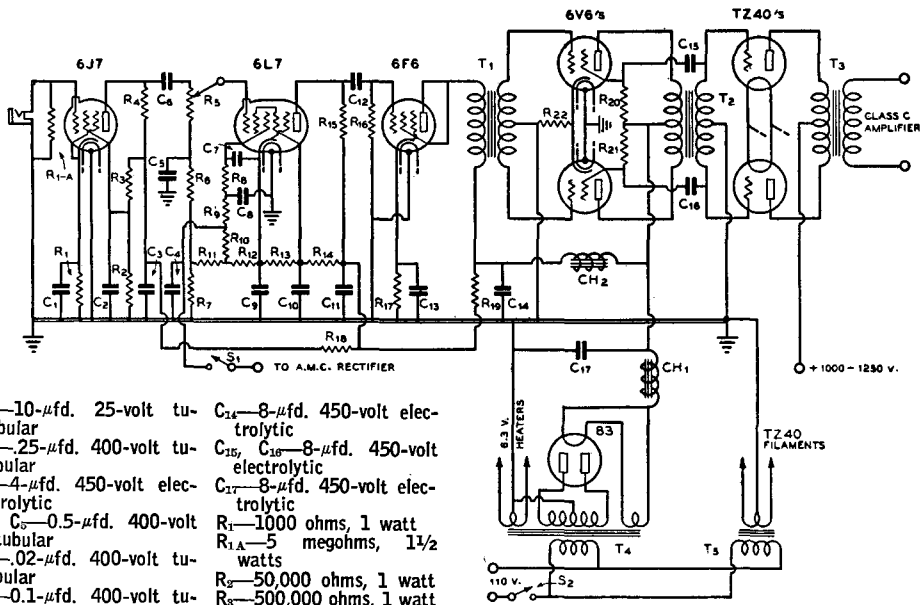

- C₁—10- μ fd. 25-volt tubular
- C₂—25- μ fd. 400-volt tubular
- C₃—4- μ fd. 450-volt electrolytic
- C₄, C₅—0.5- μ fd. 400-volt tubular
- C₆—0.02- μ fd. 400-volt tubular
- C₇—0.1- μ fd. 400-volt tubular
- C₈—0.002- μ fd. 400-volt tubular
- C₉—8- μ fd. 450-volt electrolytic
- C₁₀—0.5- μ fd. 400-volt tubular
- C₁₁—8- μ fd. 450-volt electrolytic
- C₁₂—0.05- μ fd. 400-volt tubular
- C₁₃—10- μ fd. 25-volt tubular
- C₁₄—8- μ fd. 450-volt electrolytic
- C₁₅, C₁₆—8- μ fd. 450-volt electrolytic
- C₁₇—8- μ fd. 450-volt electrolytic
- R₁—1000 ohms, 1 watt
- R_{1A}—5 megohms, 1 1/2 watts
- R₂—50,000 ohms, 1 watt
- R₃—500,000 ohms, 1 watt
- R₄—250,000 ohms, 1 watt
- R₅—500,000-ohm potentiometer
- R₆—500,000 ohms, 1 watt
- R₇—4500 ohms, 5 watts
- R₈—1 megohm, 1 watt
- R₉—100,000 ohms, 1 watt
- R₁₀—500,000 ohms, 1 watt
- R₁₁—350 ohms, 1 watt
- R₁₂—150 ohms, 1 watt
- R₁₃—5000 ohms, 5 watts
- R₁₄—7500 ohms, 5 watts
- R₁₅—100,000 ohms, 1 watt
- R₁₆—100,000 ohms, 1 watt
- R₁₇—750 ohms, 10 watts
- R₁₈—10,000 ohms, 5 watts
- R₁₉—2000 ohms, 5 watts
- R₂₀, R₂₁—5000 ohms, 3 watts
- R₂₂—300 ohms, 10 watts

- T₁—Triode power tube to p.p. power tube driver transformer
- T₂—Multi-match class-B input transformer
- T₃—Multi-match class-B output (300 watt)
- T₄—745 c.t., 145 ma.; 5 v. 3 a.; 6.3 v., 4.5 a.
- T₅—7.5 volts, 4 amperes
- CH₁—10-hy., 150 - ma. filter choke
- CH₂—10 - hy., 65 - ma. filter choke
- S₁—A.m.c. on-off switch
- S₂—110-v. a.c. switch

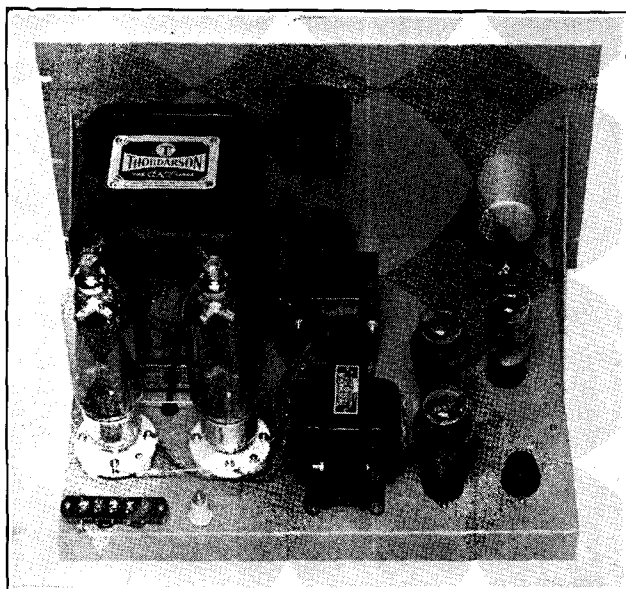

Figure 17.
203-Z SPEECH-MODULATOR
FOR INPUTS TO 800 WATTS.

The complete speech amplifier and class B output stage are built upon a single relay-rack panel and its associated chassis. The speech amplifier incorporates automatic peak limiting and uses a pair of 2A3's as drivers for the 203-Z's.

TZ-40 Operating Conditions. The TZ40's operate with zero bias under the conditions recommended by the manufacturers. The standing plate current on the two tubes is approximately 45 ma. with an applied plate voltage of 1000 volts. It will be somewhat higher, in the vicinity of 60 ma., if the full rated plate voltage of 1250 volts is used. Since this value of standing plate current results in an appreciable amount of plate dissipation, a small amount of grid bias is desirable in order to lower the plate current under no-signal conditions. A pair of $4\frac{1}{2}$ -volt batteries in series to give 9 volts is suitable as bias for 1250-volt operation.

For maximum peak power output from the TZ40's (for the adjustment which will modulate the greatest class C input with voice) the plate-to-plate load impedance for the 1000-volt conditions would be 5100 ohms. Under these conditions of operation, the modulator would be capable of 100 per cent voice-modulating at input of 500 watts to the class C stage; the plate current on the TZ40's should kick up to 200 to 250 ma. under normal modulation.

For maximum peak modulating capabilities at 1250 volts, the plate-to-plate load value should be 7400 ohms; the unit would be capable of fully modulating 600-watts input and the plate current would kick up to 175 to 225 ma. under full modulation.

If it is desired to operate the class B stage under the conventional conditions for maxi-

mum *sine-wave* audio output, the plate-to-plate load resistance would be 6800 ohms under the 1000-volt conditions; the power output would be 175 rated watts and the plate current would kick up to 250 to 275 ma. on peaks.

Complete 203Z Modulator and Speech Amplifier for Inputs Up to 800 Watts

Figures 17 and 18 show a speech amplifier and class B modulator suitable for modulating inputs from 400 to 800 watts input to the class C final stage. The speech amplifier portion of the modulator is more or less conventional except for the inclusion of automatic peak compression to allow a higher average percentage of modulation without the danger of overmodulation on occasional loud voice peaks. The delay action in the compressor (the percentage of modulation at which compression starts) can be controlled by means of the potentiometer R_{14} . All components in the 6J7 first speech stage should be thoroughly shielded to prevent grid hum and to reduce the possibility of either r.f. or audio feedback.

Operation of the Class B 203Z's. The class B operating conditions recommended by the manufacturer for sine-wave audio output are 7900 ohms plate to plate at 1250 volts on the plate and $4\frac{1}{2}$ volts of grid bias. Under these conditions the tubes will deliver 300 watts of sine-wave audio. For maximum

speech audio output the plate-to-plate load resistance should be reduced to 5500 ohms. Under these conditions the tubes will modulate an input of 800 watts as compared to the 600 watts they will modulate under sine-wave audio operating conditions.

Power supplies both for the speech amplifier portion and for the class B stage are external. 1250 volts will be required for the 203Z's and about 350 volts for the speech amplifier portion. The 1250-volt supply should have good regulation up to a maximum drain of 350 ma. and the 350-volt supply should be capable of handling 125 ma. continuously.

Simplified Automatic Modulation Control

Figure 19 shows the circuit of a simplified method of obtaining the necessary bias required for an automatic-modulation-control system. This rectifier circuit must be used

with the 60-Watt T-21 Modulator shown earlier in this chapter if satisfactory a.m.c. action is desired. Through the use of the circuit illustrated the bias required for all a.m.c. systems is placed on the rectifier tube itself instead of being placed on the cathode of the a.m.c. tube in the speech amplifier. This greatly simplifies the design of the a.m.c. stage in the speech system.

"Advance" Bias System. In the circuit diagram, this "advance" bias is obtained by means of a voltage divider consisting of a 50,000-ohm and a 500,000-ohm resistor which reduces the d.c. plate voltage applied to the diode cathode about 9%. This acts as the "advance" bias. The resistor R_1 can be of the 1-watt size for plate supplies up to 1000 volts and a 2-watt for up to 2000 volts. The 500,000-ohm resistor can be made of ten similar carbon resistors wired in series and well insulated from the chassis. C_1 , R_1 and R_2 can be mounted on bakelite resistor mounting strips or panels about one inch away from the

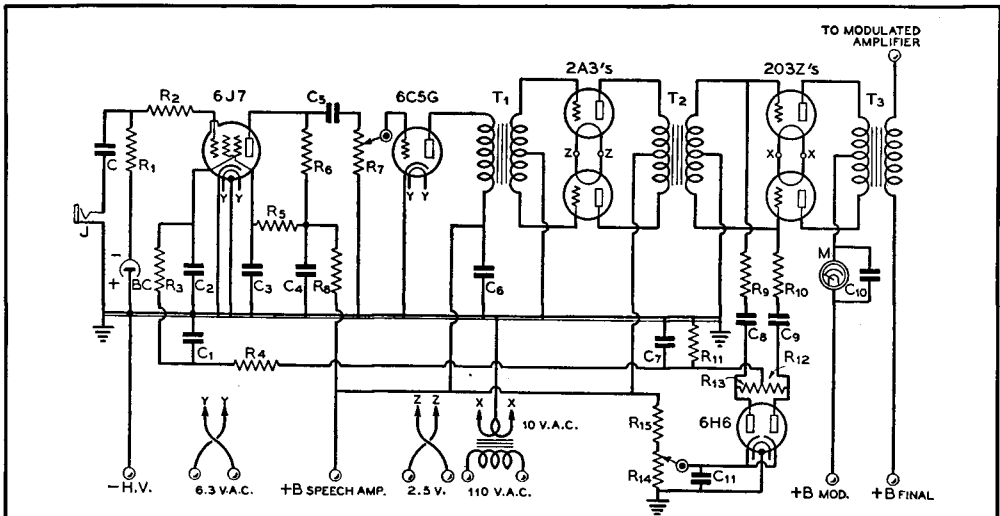

Figure 18.

WIRING DIAGRAM OF THE CLASS B 203-Z MODULATOR.

- | | | | |
|---|--|--|--|
| C_1 —0.1- μ fd. 400-volt tubular | C_9 —0.5- μ fd. 400-volt tubular | R_4 —300,000 ohms, 1/2 watt | R_{14} —50,000-ohm potentiometer |
| C_2 —0.1- μ fd. 400-volt tubular | C_7 —0.25- μ fd. 400-volt tubular | R_5 —1.0 megohm, 1/2 watt | R_{15} —100,000 ohms, 1 watt |
| C_3 —0.1- μ fd. 400-volt tubular | C_8, C_{10} —0.1- μ fd. 400-volt tubular | R_6 —250,000 ohms, 1/2 watt | J—Microphone jack |
| C_4 —0.25- μ fd. 400-volt tubular | C_{11} —1.0- μ fd. paper, 400 volts | R_7 —1.0-megohm potentiometer | BC—Bias cell |
| C_5 —0.5- μ fd. 400-volt tubular | R_1 —1.0 megohm, 1/2 watt | R_8 —50,000 ohms, 1/2 watt | T_1 —Push-pull input trans. |
| C_6 —0.1- μ fd. 400-volt tubular | R_2 —50,000 ohms, 1/2 watt | R_9, R_{10} —2.0 megohms, 1/2 watt | T_2 —Class-B input for 203Z's |
| | R_3 —250,000 ohms, 1/2 watt | R_{11}, R_{12}, R_{13} —100,000 ohms, 1 watt | T_3 —300-watt variable-ratio modulation trans. |
| | | | M—0-500 d.c. milliammeter |

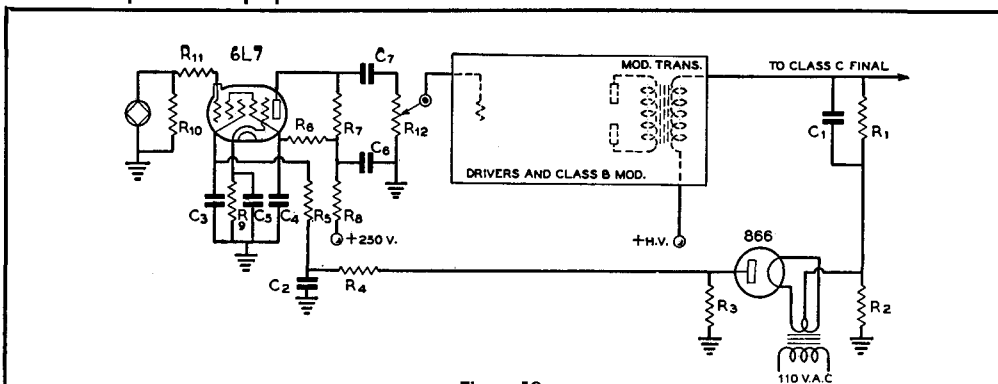

Figure 19.

A.M.C. ARRANGEMENT WITH SIMPLIFIED BIAS SYSTEM.

- | | | |
|--|---|--|
| C ₁ —0.5- μ fd. 600-volt tubular | trolytic shunted by .01- μ fd. 400-volt tubular | R ₇ —200,000 ohms, 1 watt |
| C ₂ —0.1- μ fd. 400-volt tubular | C ₅ —0.5- μ fd. 400-volt tubular | R ₈ —30,000 ohms, 1 watt |
| C ₃ , C ₄ —0.5- μ fd. 400-volt tubular | C ₇ —0.02- μ fd. 400-volt tubular | R ₉ —100,000 ohms, 1 watt |
| C ₆ —10- μ fd. 25-volt elec- | R ₁ —50,000 ohms, 2 to 20 watts (see text) | R ₁₀ —500,000 ohms, 1/2 watt |
| | | R ₁₁ —1.0 megohm, 1/2 watt |
| | | R ₁₂ —500,000-ohm potentiometer |

chassis with the strip mounted on stand off insulators. The diode filament transformer must also be well insulated between windings in order to withstand the peaks in the positive direction.

The Rectifier Diode. The diode itself must have sufficient inverse peak rating, which means that an 866 Jr. is suitable for use in sets with plate supplies up to 1000 volts, and 866 up to 2500 volts and an 879 for higher plate supplies. Mercury vapor in the rectifiers seems to make no difference in operation at the low currents used in a.m.c. circuits.

The purpose of C₁ in the circuit diagram is to by-pass the audio peak overload voltage into the diode cathode. The diode then has the full amount of a.e. peak across it and a little over 90% of the d.c. plate voltage. C₁ can be a one-half or one μ fd. 400- or 600-volt paper condenser as long as it is mounted well in the clear of nearby grids.

The control bias is developed across R₃ which can be of any value between 100,000 and 250,000 ohms. No condenser should be connected across this resistor unless there is some stray r.f. present. If there should be any it must be by-passed with a small .002- μ fd. condenser. The time delay circuit should be confined mainly to C₃ and R₅, which can have values of 0.5 μ fd. and 1 megohm in most speech transmitters. Additional audio filter in the form of C₂, 0.1 μ fd., and R₄, half megohm, is generally necessary to prevent audio feedback and a "blurring" effect on high

levels of speech input. These resistors can be of one-half or one watt size.

A.M.C. Tubes. It is possible to supply a.m.c. voltage to the control grid of an amplifier such as to a 6K7 or even a 6N7. The suppressor grid of a 6C6, 6J7 or 6K7, requires about twice as much negative bias for the same reduction in gain as does the injector grid of a 6L7. It is advisable to use a 6L7 whenever possible. However, this a.m.c. circuit can be applied to nearly any existing phone transmitter with hardly any changes in the speech amplifier.

A.M.C. Advantages. A.m.c. practically eliminates sideband splatter in all cases and prevents modulation in excess of 100 per cent. In addition it allows an average higher level of modulation which results in better signal at the receiver. The two phone transmitters of the same carrier output, one with a.m.c. and one without, both not overmodulated will have about 2 to 3 db difference in level. The 3 db increase available from the use of a.m.c. is equivalent to doubling the carrier signal in effect.

One other point should be mentioned; a.m.c. will handle only from 15 to 20 db excessive level peaks without considerable audio distortion. So don't try to push the average modulation level up to 99% at all times. Use the manual gain control, too, and keep the level of modulation down to a point where it sounds right in a monitor. An oscilloscope will usually indicate 100% modulation many

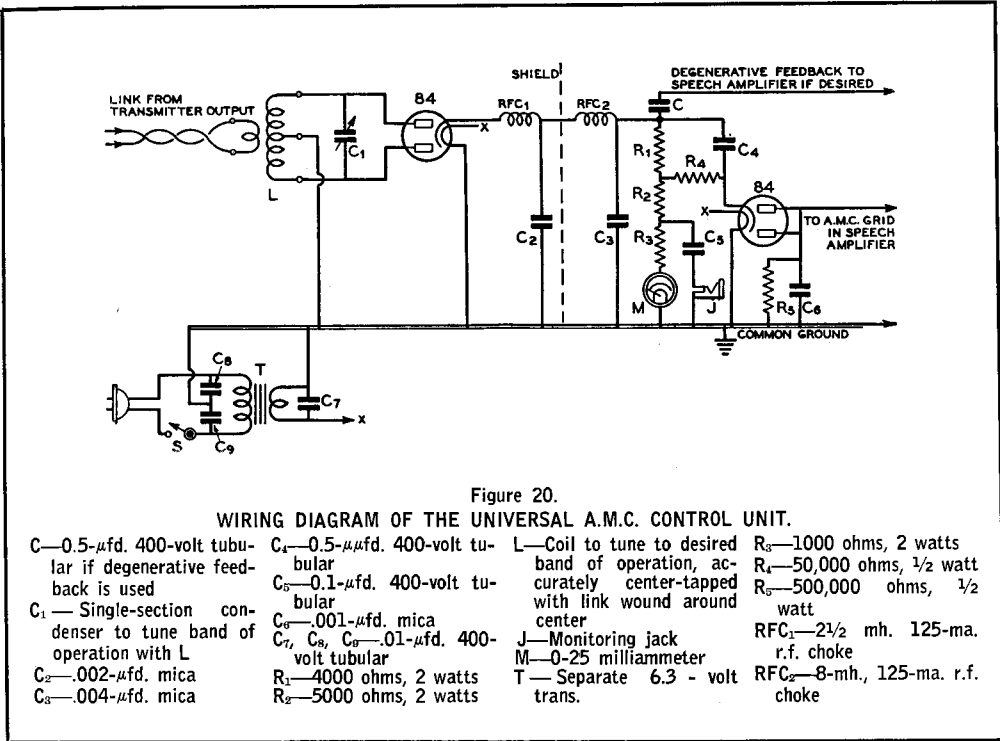

times a minute on an average speech when the gain adjustment is correct for good monitor quality.

The a.m.c. circuit shown in figure 19, however, is *not* suitable for use with the TZ40 speech amplifier-modulator shown in figure 14. All this speech amplifier requires is a half-wave rectifier. The same voltage ratings apply for this rectifier as for the one just described, with the c.t. of its filament connected directly to the plate voltage lead to the plate modulated stage, and the plate connected to the input terminal on the amplifier.

Universal A.M.C. Circuit

The previous a.m.c. circuits which have been shown are only for use with plate modulated final amplifier stages. Hence, these circuits rule out the use of a.m.c. with its attendant advantages with linears, grid-modulated amplifiers, and cathode modulation. To alleviate this difficulty the following a.m.c. circuit was developed which can be used with any system of modulation and with any type of final amplifier stage.

Operation from the Carrier. The feature which distinguishes this a.m.c. arrangement from all others is that the peak rectifier unit

operates directly from the carrier output of the transmitter instead of operating from the modulated plate voltage of the final amplifier stage. The system uses two 84 rectifiers; one which rectifies the incoming carrier and supplies the rectified d.c. voltage with the modulation component across a load resistor, and the other which rectifies all peaks above a certain fixed value and supplies the rectified peaks to the a.m.c. stage is the speech amplifier. Since the unit requires only modulated carrier voltage for its operation, any type of amplitude modulated transmitter may be used with it.

Carrier Shift Indication. It will be noticed by reference to figure 20 that a milliammeter has been included as a part of the unit. This meter is not, of course, absolutely necessary. However, if the meter is not included it will be necessary to install a closed-circuit jack in the circuit so that a suitable milliammeter may be inserted to tune the a.m.c. unit properly.

It is recommended, however, that a 0-25 or 0-50 d.c. milliammeter be included as a part of the circuit as shown by the circuit diagram since the instrument can, if left in the circuit, also serve the purpose of a carrier shift indicator. The normal load current should be

(7) Shield the input and low-level stage tubes. (8) Use a good ground connection to the metal chassis (waterpipe or ground rod connection). (9) Ground all transformer and choke coil cores. (10) Use metal cabinets and chassis, rather than breadboard construction. (11) Bypass low-level audio stage cathode by-pass electrolytic condensers with a .002- μ fd. mica condenser for the purpose of preventing rectification of stray r.f. energy which will sometimes produce hum.

The power supply for a speech amplifier should be exceptionally well filtered. This may require three sections of filter, consisting of three high-capacity condensers and two or three filter chokes. When space permits, the power supply should be placed several feet from the speech amplifier.

Shielding. The speech amplifier and microphone leads should be completely shielded for the elimination of r.f. feedback. A concentric or a *balanced* two-wire r.f. transmission line to a remotely located antenna is the most effective method of preventing r.f. feedback into the microphone or speech amplifier circuits in the range of from 5 to 20 meters.

The impedance of ground leads at such short wavelengths makes it impossible completely to eliminate stray r.f. currents. End-fed antennas and single-wire fed systems are particularly troublesome with respect to r.f. feedback.

Audio feedback may cause motor-boating, whistling or howling noises in the audio amplifiers. Insufficient by-pass capacity across the plate supply of a multistage speech amplifier is one cause of motor-boating. The first stage of a speech amplifier should have a resistance filter in its plate supply lead, which may consist of a 10,000- to 50,000-ohm 1-watt resistor in series with the positive B lead, with a $\frac{1}{2}$ - μ fd. condenser connected to ground from the amplifier side of the series resistor. (See figure 22.)

A defective tube will introduce hum or distortion, as well as affect the overall gain or power output of an audio amplifier. Incorrect bias on any amplifier stage will produce harmonic distortion, which changes the quality of speech. This bias voltage should be of the correct value for the actual plate-to-cathode voltage, rather than the plate supply output voltage (these may be widely different in a resistance-coupled stage). Excessive audio input to any amplifier stage will produce amplitude distortion. Incorrect plate coupling impedances or resistances will cause distortion. A damaged or inferior microphone is another source of distortion. Cathode resistors should be by-passed with ample

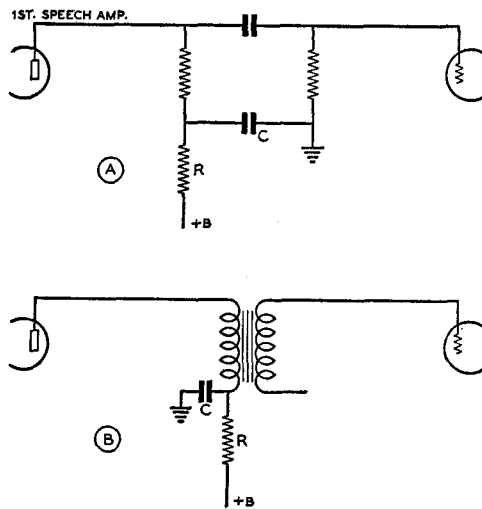

Figure 22.

RC FILTER CIRCUITS FOR USE IN DECOUPLING AUDIO STAGES.

The value of resistor R can be from 2000 to 50,000 ohms; C can be from 1 to 8 μ fd.

capacity to provide a low impedance path for the lowest frequencies. Push-pull and especially class B amplifiers require balanced tubes.

Power Supplies for Radiotelephony

A power supply for a radiotelephone transmitter should furnish nonpulsating d.c. voltage to the crystal oscillator or other source of frequency control. The amount of pulsation or ripple voltage should be less than 1 per cent of the d.c. voltage, especially for radio transmitters operating on very high frequencies. Hum or ripple voltage in the plate supply to the oscillator will frequency-modulate the r.f. output slightly. Each frequency multiplier stage increases the frequency modulation, until the carrier hum becomes objectionable in high-frequency transmitters. Many amateur 10-meter phones suffer from this difficulty, noticed especially with selective receivers.

The power supply for the front end of the speech channel must be thoroughly filtered in order to avoid amplification of the ripple in the succeeding audio or speech amplifier stages. The plate supply for the final audio amplifier stage does not require as much filter as the preceding stages, and, in the case of a push-pull audio modulator stage, a single-section filter will suffice.

Buffer stages of a control-grid modulated transmitter must have very well-filtered plate supplies (more than the buffers in a plate-modulated transmitter) in order to prevent hum modulation in the grid circuit on which the speech audio frequencies are impressed. On the other hand, the plate supply for the grid-modulated stage itself does not require quite as much filter as does a comparable plate-modulated stage. This indicates that a single-section filter will suffice for a grid-modulated stage, whereas a two-section filter is desirable for plate modulation. In the event that only a single-section filter is used for a grid-modulated stage, condenser input is desirable. A single-section choke input filter does not furnish sufficient ripple suppression except for a c.w. amplifier or push-pull (or push-pull class-B) modulator stage.

Class-B Modulator Voltage Regulation. Power supply voltage regulation of Class-B

modulators is of great importance because the plate current varies appreciably with the amount of speech input. Choke input, utilizing preferably a *swinging-choke* with high no-current inductance rating (25 hy. or more) and low d.c. resistance, in conjunction with mercury vapor rectifiers and a husky filter condenser (at least 4 μ fd.) will make a good power supply. If the resting plate current of the modulator tubes is high, as is the case with some of the zero bias, class-B tubes, a swinging type choke is not essential; however, even so, the choke should have high inductance (10 or 20 hy.).

A comparatively high degree of ripple as compared to a modulated amplifier power supply can be tolerated in a power supply feeding a push-pull audio or modulator stage, because a good percentage of the hum is cancelled out in the coupling transformer if the modulator tubes are well matched.

CHAPTER FIFTEEN

Power Supplies

Rectification

Any device which incorporates vacuum tubes requires a power supply for the filament and plate circuits of the tube or tubes. The filaments of the tubes must be heated in order to produce a source of electrons within the vacuum tubes; direct-current voltages are needed for the other electrodes in order to obtain detection, amplification, oscillation and rectification.

Either a.c. or d.c. voltage may be used for filament power supply in most applications; however, the a.c. power supply is the more economical and can be used with most tubes without introduction of hum in the output of the vacuum tube device. The plate potential must be secured from a d.c. source, such as from batteries or a rectified and filtered a.c. power supply.

First the a.c. must be converted into a unidirectional current; this is accomplished by means of vacuum tube *rectifiers*, of either the *full-* or *half-wave* type.

Half-Wave Rectifiers. A half-wave rectifier passes one half of the wave of each alteration of the a.c. current and blocks the other half. The output current is of a *pulsating* nature, which can be smoothed into pure, direct current by means of *filter* circuits. Half-wave rectifiers produce a pulsating current which has zero output during one half of each a.c. cycle; this makes it difficult to filter the output properly into d.c. and also to secure good voltage regulation for varying loads.

Full-Wave Rectifiers. A full wave rectifier consists of a pair of half-wave rectifiers working on opposite halves of the cycle, connected in such a manner that each half of the rectified a.c. wave is combined in the output as shown in figure 1. This pulsating unidirectional current can be filtered to any desired degree, depending upon the particular application for which the power supply is designed.

A full-wave rectifier consists of two plates

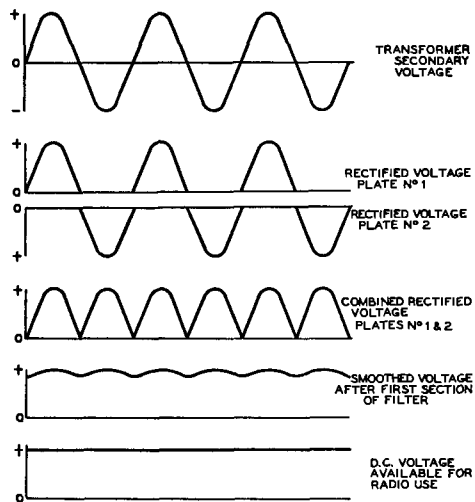

Figure 1.
FULL-WAVE RECTIFICATION.
Showing effects of rectification and filtering of an alternating current. A full-wave rectifier is shown in figure 2.

and a filament, either in a single glass or metal envelope for low-voltage rectification or in the form of two separate tubes, each having a single plate and filament for high-voltage rectification. The plates are connected across the high-voltage a.c. power transformer winding, as shown in figure 2. The power transformer is for the purpose of transforming the 110-volt a.c. line supply to the desired secondary a.c. voltages for filament and plate supplies. The transformer delivers alternating current to the two plates of the rectifier tube; one of these plates is positive at any instant during which the other is negative. The center point of the high-voltage transformer winding is usually grounded and is, therefore, at zero voltage, thereby constituting the *negative B connection*.

While one plate of the rectifier tube is conducting, the other is inoperative, and vice versa. The output voltages from the rectifier tubes are connected together through a common rectifier filament circuit, and thus the plates alternately supply pulsating current to the output (load) circuit. The rectifier tube filaments are always positive in polarity with respect to the output in this type circuit.

The output current pulsates 120 times per second for a full-wave rectifier connected to a 60-cycle a.c. line supply, and the output from the rectifier must connect to a *filter*, which will smooth the pulsations into direct current. Filters are designed to select or reject alternating currents; those most commonly used in a.c. power supplies are of the *low-pass* type. This means that pulsating currents which have a frequency below the cutoff frequency of the filter will pass through the filter to the load. Direct current can be considered as alternating current of zero frequency; this passes through the low-pass filter. The 120-cycle pulsations are similar to alternating current in characteristic, so that the filter must be designed to have a *cutoff* at a frequency lower than 120 cycles (for a 60 cycle a.c. supply).

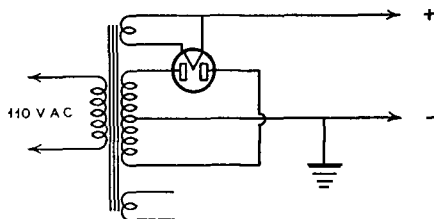

Figure 2.
STANDARD FULL-WAVE SINGLE-PHASE
RECTIFIER CIRCUIT.

Filter Circuits

A low-pass filter consists of combinations of inductance and capacitance. An inductance or *choke coil* offers an impedance to any change in the current that flows through it. A high-inductance choke coil offers a relatively high resistance to the flow of pulsating current, with the result that the *a.c. component* or *ripple* passes from the rectifier tube through the load only with the greatest of difficulty. A capacitance has exactly the opposite action to that of an inductance. It offers a low impedance path to the flow of alternating or pulsating current, but presents practically infinite resistance to the flow of direct cur-

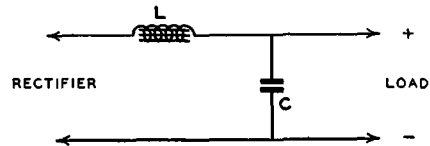

Figure 3.
SIMPLE, SINGLE-SECTION CHOKE-
INPUT FILTER.

With commonly used values of L and C , the percentage ripple will be between 3 and 10 per cent, depending upon the load resistance. This type of filter is often used to feed a push-pull modulator stage (in which much of the plate voltage ripple cancels out) and telegraphy amplifiers in which slight modulation of the carrier can be tolerated.

rent. Inductance coils are usually connected in series with the rectifier outputs, while condensers are connected across the positive and negative leads of the output circuit. A simple filter circuit is shown in figure 3.

Electricity always follows the path of least resistance or impedance. The direct current will travel through the choke and back to the ground (negative B) connection through the *external load*, which normally consists of the plate circuits of vacuum tubes. The a.c. component, or ripple, tends to be impeded by the choke and short-circuited by the condensers across the filter, which offer a lower reactance to the pulsating voltage than that offered by the load. The *load impedance* across the output of most filter systems is generally high, usually from 5,000 to 10,000 ohms. This load resistance can be calculated by dividing the output voltage by the total load current; this value is necessary in making calculations for low-pass resonant types of filter circuits.

Resonant Type Filters. In figure 4, condenser C_1 tunes the choke coil inductance to series resonance at the ripple frequency. Series resonance provides a very low impedance to the resonant frequency limited only by the

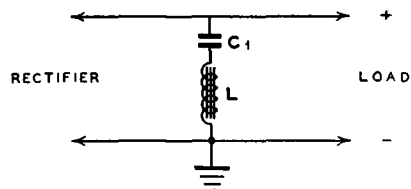

Figure 4.
SERIES RESONANT FILTER CIRCUIT.

If the ripple voltage is high, a high a.c. component will appear across each reactance. With high values of L and correspondingly low values of C , the a.c. voltage across each of these components may exceed the d.c. supply voltage.

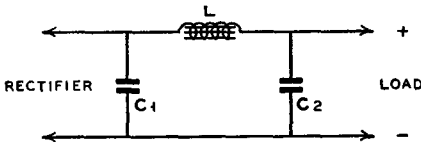

Figure 5.

SINGLE-SECTION CONDENSER INPUT OR π TYPE FILTER.

This filter is also known as a low-pass or "brute force" filter.

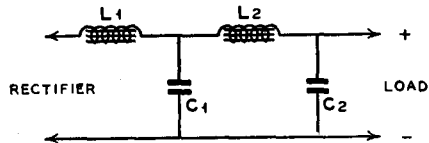

Figure 7.

LOW-PASS "BRUTE FORCE" FILTER WITH INPUT CHOKE.

Adding an input choke to the "brute force" filter improves both regulation and filtering at a sacrifice in output voltage.

actual resistance of the choke coil (since the reactance of both the condenser C_1 and the choke coil cancel each other).

The filter circuit in figure 4 accomplishes the same purpose as a large shunt condenser at the ripple frequency, but is not effective in short-circuiting the higher harmonics in the output of the rectifier system. Additional low-pass filter circuits are needed to remove these harmonic components, which are of great enough magnitude to produce objectionable high-pitched hum in the vacuum tube amplifier circuits.

A typical low-pass filter is diagrammed in figure 5. The combination of C_1 , C_2 and L should give a cutoff frequency below that of the rectified output pulsation frequency.

This type of filter is very effective, yet un-critical because the circuit can be designed with any cutoff frequency, as long as the attenuation or rejection at the 120-cycle-and-higher harmonic frequencies is great. This type of filter is sometimes called a "brute force" filter, because large values of inductance and capacitance are normally used without much attention being paid to the actual cutoff frequency. Inductance values of 10 to 30 henrys are used for filter chokes, and shunt capacities of from 2 to 16 microfarads commonly are used for C_1 and C_2 in figure 5.

A resonant trap circuit, such as shown in figure 6, is sometimes used to increase the impedance of the choke L at some particular frequency, such as 120 cycles per second.

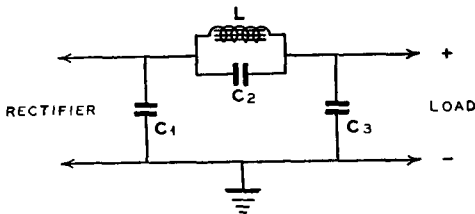
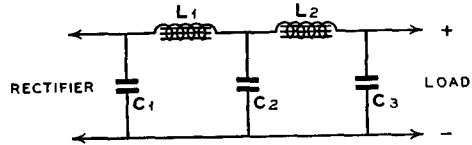

Figure 6.

"BRUTE FORCE" FILTER WITH CHOKE RESONATED TO RIPPLE FREQUENCY TO INCREASE IMPEDANCE.

Figure 8.
TWO-SECTION LOW-PASS FILTER FOR USE WHERE VERY PURE D.C. IS REQUIRED.

This type of power supply filter is widely used in conjunction with low level speech amplifier stages.



Parallel resonance of C_2 and L provides a very high impedance at the resonant frequency. The condenser C tends to by-pass the higher ripple harmonics that get through the trap circuit. This type of filter is often used in conjunction with an additional section of filter of the type shown in figure 3.

The single-section, low-pass filter in figure 5 is often combined with an additional choke coil as shown in figure 7. The additional choke coil L_1 is an aid in filtering and also provides better voltage regulation for varying d.c. loads, such as presented by a class-B audio amplifier.

A two-section, low-pass filter with condenser input is shown in figure 8. In some cases, additional sections of choke coils and condensers are added for the purpose of obtaining very pure direct current.

Resistors may be used in place of inductances in circuits where the load current is of low value, or where the applied d.c. voltage must be reduced to some desired value.

The ripple in the output of a filter circuit can be measured with an oscilloscope or by means of the simple circuit in figure 9. A high-voltage condenser C_3 , having a capacity of from $\frac{1}{4}$ to 1 μ fd., and a high-resistance copper-oxide a.c. voltmeter provides a method of measuring the actual ripple voltage.

The voltmeter should be plugged into the measuring jack after the power supply and external load circuit are in normal operating condition, and the meter should be removed

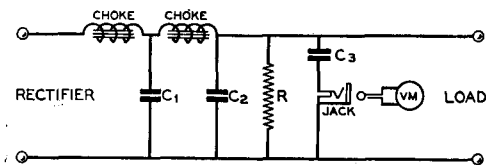

Figure 9.
CIRCUIT FOR MEASURING A.C. RIPPLE.

The meter should not be inserted in the circuit until after the voltage is turned on; otherwise the charging current surge may blow the meter. The jack must be of the closed circuit type. C_3 must be rated at considerably more than the plate voltage to provide a safety factor.

from the shorting type jack before turning off the power supply or removing the load. The charging current through condenser C_3 would soon burn out the meter if it were left in the circuit at all times.

Rectifier and Filter Circuit Considerations

The shunt condensers in a filter system serve a dual purpose. They provide: (1) a low impedance path for ripple, (2) an energy-storing system for maintaining constant power output from the power supply. The condensers are charged when the peak voltage is applied across them from the output of the rectifier; during the time in which the rectifier output decreases to zero, the filter condensers supply output current to the load. This action provides a constant output voltage.

R.M.S. and Peak Values. In an a.c. circuit, the maximum peak voltage or current is the square root of 2 or 1.41 times that indicated by the a.c. meters in the circuit. The meters read the *root-mean-square* (r.m.s.) values, which are the peak values divided by 1.41 for a sine wave.

If a potential of 1,000 r.m.s. volts is obtained from a high-voltage secondary winding of a transformer, there will be 1,410-volts peak potential from the rectifier plate to ground. The rectifier tube has this voltage impressed on it, either positively when the current flows or "inverse" when the current is blocked on the other half-cycle. The *inverse peak voltage* which the tube will stand safely is used as a rating for rectifier tubes. At higher voltages the tube is liable to arc back, thereby destroying it. The relations between peak inverse voltage, total transformer voltage and filter output voltage depend upon the characteristics of the filter and rectifier circuits (whether full- or half-wave, bridge, etc.).

Rectifier tubes are also rated in terms of *peak current load*. The actual direct load current which can be drawn from a given rectifier tube or tubes depends upon the type of filter circuit. A full-wave rectifier with condenser input may be called upon to deliver a peak current several times the direct load current.

In a filter with choke input, the peak current is not much greater than the load current if the inductance of the choke is fairly high (assuming full wave rectification).

A full-wave rectifier with two rectifier elements requires a transformer which delivers twice as much a.c. voltage as would be the case with a half-wave rectifier or bridge rectifier.

Bridge Rectification. The bridge rectifier is a type of full-wave circuit in which four rectifier elements or tubes are operated from a single high-voltage winding on the power transformer.

While twice as much output voltage can be obtained from a bridge rectifier as from a center-tapped circuit, the permissible output current is only one-half as great for a given power transformer. In the bridge circuit, four rectifiers and three filament heating transformer windings are needed, as against two rectifiers and one filament winding in the center-tapped full-wave circuit. In a bridge rectifier circuit, the inverse peak voltage impressed on any one rectifier tube is halved, which means that tubes of lower peak voltage rating can be used for a given voltage output.

The output voltage across the filter circuit depends upon the design of the filter, resistance of rectifier power transformer and load resistance. A low-resistance rectifier, such as the mercury-vapor type 83 or 866, has very low voltage drop in comparison with most *high-vacuum* (not mercury-filled) rectifiers. The filter circuit with *condenser input*, i.e., a condenser across the rectifier output, will deliver a higher d.c. voltage than one with *choke input*, but with a sacrifice both in voltage regulation and the amount of available load current.

The d.c. voltage across the load circuit of a condenser-input filter may be as high as 1.4 times the a.c. input voltage (r.m.s.) across one of the rectifier tubes if the input condenser capacity is large and the current drain small. Low values of load resistance (heavy current drain) will cause this type of power supply to have a d.c. voltage output as low or even lower than the a.c. input to the rectifier. The maximum permissible load current in this same circuit is less for a given transformer-secondary wire size and rectifier tube peak

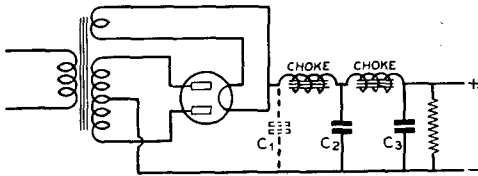

Figure 10.
STANDARD TWO-SECTION FILTER.
When C_1 is connected in the circuit, the filter is termed "condenser input." If C_1 is omitted, the filter is called "choke input."

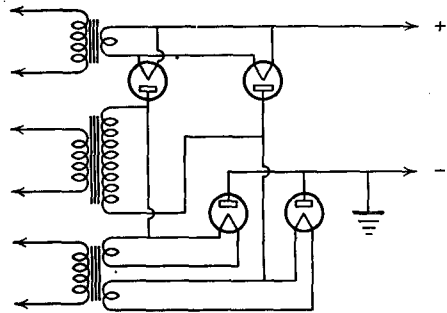

Figure 11.
BRIDGE RECTIFIER CIRCUIT.

current rating than would be the case for a choke-input filter.

A choke-input filter will reduce the d.c. voltage to a value of 0.9 the a.c., r.m.s. value, but the output voltage with choke input is fairly constant over a wide range of load resistances, and the allowable load current is greater than with condenser input for a given rectifier and power transformer.

Filter Choke Coils. Filter inductors often consist of a coil of wire wound on a laminated iron or steel core. The size of wire is determined by the amount of direct current which is to flow through the choke coil. This direct current magnetizes the core and reduces the inductance of the choke coil; therefore, filter choke coils of the "smoothing" type are built with an air gap, a small fraction of an inch in the iron core, for the purpose of preventing saturation when maximum d.c. flows through the coil winding.

This "air gap" is usually in the form of a piece of fiber inserted between the ends of the laminations. The air gap reduces the initial inductance of the choke coil, but keeps it at a higher value under maximum load conditions. The coil must have a great many more turns for the same initial inductance when an air gap is used.

As mentioned previously, choke input tends to keep the output voltage of the filter at approximately 0.9 of the r.m.s. voltage impressed upon the filter from the rectifiers. However, this effect does not take place until the load current exceeds a certain minimum value. In other words, as the load current is decreased, at a certain critical point the output voltage begins to soar. This point is determined by the inductance of the input choke. If it has high inductance, the current can be reduced to a very low value before the output voltage begins to rise. Under these conditions, a low-drain bleeder resistor will keep the current in excess of the critical point and the voltage will not soar even if the external load is removed.

For this purpose, chokes are made with little or no air gap in order to give them more inductance at low values of current. Their filtering effectiveness at maximum current is impaired somewhat, because they saturate easily, but their high inductance at low values of current permits use of a smaller bleeder to keep the current in excess of the critical value. Such chokes are called *swinging chokes* because, while they have high initial inductance, the inductance rapidly falls to a comparatively low value as the current through the choke is increased.

The d.c. resistance of any filter choke should be as low as possible in conjunction with the desired value of inductance. Small filter chokes, such as those used in radio receivers, usually have an inductance of from 20 to 30 henrys, and a d.c. resistance of from 200 to 400 ohms. A high d.c. resistance will reduce the output voltage, due to the voltage drop across each choke coil. Large filter choke coils for radio transmitters and class-B amplifiers usually have less than 100-ohms d.c. resistance.

Filter Condensers. There are two types of filter condensers: (1) paper dielectric type, (2) electrolytic type.

Paper condensers consist of two strips of metal foil separated by several layers of waxed paper. Some types of paper condensers are wax-impregnated; others, especially the high-voltage types, are oil-impregnated. High voltage filter condensers which are oil-impregnated will withstand a greater peak voltage than those impregnated with wax, but they are more expensive to manufacture. Condensers are rated both for *flash* test and normal operating voltages; the latter is the important rating and is the maximum voltage which the condenser should be required to withstand in service.

The condenser across the rectifier circuit in a condenser-input filter should have a working voltage rating equal to at least 1.41 times the r.m.s. voltage output of the rectifier. The remaining condensers may be rated more nearly in accordance with the d.c. voltage.

Electrolytic condensers are of two types: (1) wet, (2) dry. The wet electrolytic condenser consists of two aluminum electrodes immersed in a solution called an *electrolyte*. A very thin film of oxide is formed on the surface of one electrode, called the *anode*. This acts as the dielectric. The electrolytic condenser must be correctly connected in the circuit so that the anode always is at positive potential with respect to the electrolyte, the latter actually serving as the other electrode (plate) of the condenser. A reversal of the polarity for any length of time will ruin the condenser.

The dry type of electrolytic condenser uses an electrolyte in the form of paste. The dielectric in both kinds of electrolytic condensers is not perfect; these condensers have a much higher direct current leakage than the paper type. The leakage current is greater in the wet electrolytic than in the dry types, but the former are self-healing and are not permanently damaged by moderate voltage overloads.

The high capacitance of electrolytic condensers results from the thinness of the film which is formed on the plates. The maximum voltage that can be safely impressed across the average electrolytic filter condenser is between 450 and 600 volts; the working voltage is usually rated at 450. When electrolytic condensers are used in filter circuits of high-voltage supplies, the condensers should be connected in series. The positive terminal of one condenser must connect to the negative terminal of the other, in the same manner as dry batteries are connected in series.

It is not necessary to connect shunt resistors across each electrolytic condenser section as it is with paper capacitors connected in series, because electrolytic capacitors have fairly low internal d.c. resistance as compared to paper condensers. Also, if there is any variation in resistance, it is that electrolytic unit in the poorest condition which will have the highest leakage current, and therefore the voltage across this condenser will be lower than that across one of the series connected units in better condition and having higher internal resistance. Thus we see that equalizing resistors are not only unnecessary across series connected electrolytic condensers but are actually undesirable. This assumes, of course, similar capacitors by the same manu-

facturer and of the same capacity and voltage rating. It is *not advisable* to connect in series electrolytic condensers of different make or ratings.

There is very little economy in using electrolytic condensers in series in circuits where more than two of these condensers would be required to prevent voltage breakdown.

Wet electrolytic capacitors housed in an aluminum can ordinarily use the can as the negative electrode, or contact to the electrolyte (the electrolyte being the true electrode). Wet electrolytic condensers should always be mounted in a vertical position. To allow escape of gas generated as a result of electrolysis, a small vent is provided.

Electrolytic condensers can be greatly reduced in size by use of etched aluminum foil for the anode. This greatly increases the surface area, and the dielectric film covering it, but raises the power factor slightly. For this reason ultra-midget electrolytic condensers should not be used at full rated d.c. voltage when a high a.c. component is present, such as would be the case for the input condenser in a condenser-input filter.

When a dry (paste electrolyte) electrolytic condenser is subjected to over voltage and the leakage current is increased substantially, the condenser may be considered as no longer fit for service, as heating caused by the rupture will aggravate the condition. As previously mentioned, mildly ruptured *wet* electrolytic condensers will heal if normal voltage is applied to them for a time.

Bleeder Resistors. A heavy-duty resistor should be connected across the output of a filter in order to draw some load current at all times. This resistor avoids soaring of the voltage at no load when swinging choke input is used and also provides a means for discharging the filter condensers when no external vacuum-tube circuit load is connected to the filter. This *bleeder* resistor should normally draw approximately 10 per cent of the full load current.

The power dissipated in the bleeder resistor can be calculated by dividing the square of the d.c. voltage by the resistance. This power is dissipated in the form of heat, and, if the resistor is not in a well-ventilated position, the wattage rating should be higher than the actual wattage being dissipated. High voltage, high capacity filter condensers can hold a dangerous charge if not bled off, and wire wound resistors occasionally open up without warning. Hence it is wise to place carbon resistors in series across the regular wire wound bleeder as explained in chapter 10 under *safety precautions*.

When purchasing a bleeder resistor, be sure that the resistor will stand not only the required wattage, but also the *voltage*. Some resistors have a voltage limitation which makes it impossible to force sufficient current through them to result in rated wattage dissipation. This type of resistor usually is provided with slider taps, and is designed for voltage divider service. An untapped, non-adjustable resistor is preferable as a high voltage bleeder, and is less expensive. Several small resistors may be used in series if desired in order to obtain the required wattage and voltage rating.

Glow-Discharge Voltage Regulators. Two very useful tubes for stabilizing the voltage on receivers, electron coupled oscillators in exciters, frequency meters, and other devices requiring a constant source of voltage of between 100 and 300 volts are the VR-105-30 and VR-150-30 glow-discharge type voltage-regulator tubes. These tubes are similar except that the VR-105 has a lower voltage drop (105 volts) than the VR-150 (150 volts). The remarks following apply generally to both, though the examples apply specifically to the VR-150. Both tubes have the same current rating.

The VR-105 is useful for stabilizing the voltage on the oscillator section of 6J8, 6K8 and similar mixer tubes, for use in the cathode of the feedback tube in a 2A3 type voltage regulated power supply, and many other applications. The VR-150 is suited where higher voltage is desirable.

Two VR type tubes may be connected in series to provide exactly 210, 255, or 300 volts when more than 150 volts is required.

A VR type tube may be used to stabilize the voltage across a variable load or the voltage across a constant load fed from a varying source of voltage. Thus can be seen their many possible applications and wide range of usefulness.

A device requiring, say, only 50 volts can be stabilized against *supply voltage* variations by means of a VR-105 simply by putting a suitable resistor in series with the regulated voltage and the load, dropping the voltage from 105 to 50 volts. However it should be borne in mind that under these conditions the device will *not* be regulated for *varying load*; in other words if the *load resistance* varies, the voltage across the load will vary, even though the regulated voltage remains at 105 volts.

To maintain constant voltage across a *varying load resistance* there must be *no* series resistance between the regulator tube and the load. This means that the device must be op-

erated exactly at one of the five voltages mentioned if regulation is to be obtained with not more than two VR tubes.

A VR-150 may be considered as a stubborn variable resistor having a range of from 30,000 to 5000 ohms and so intent upon maintaining a fixed voltage of 150 volts across its terminals that when connected across a voltage source having *very poor regulation* it will instantly vary its own resistance within the limits of 5000 and 30,000 ohms in an attempt to maintain the same 150 volt drop across its terminals when the supply voltage is varied. The theory upon which a VR tube operates is covered under the subject of gaseous conduction in the chapter on *Vacuum Tube Theory*, and will not be discussed here.

It is paradoxical that in order to do a good job of regulating, the regulator tube must be fed from a voltage source having poor regulation (high series resistance). The reason for this presently will become apparent.

If a high resistance is connected across the VR tube, it will not impair its ability to maintain a 150 volt drop. However, if the load is made too low, a variable 5000 to 30,000 ohm shunt resistance (the VR-150) will not exert sufficient effect upon the resulting resistance to provide constant voltage except over a *very limited* change in supply voltage or load resistance. The tube will supply maximum regulation, or regulate the largest load, when the source of supply voltage has high internal or high series resistance, because a variation in the effective internal resistance of the VR tube will then have more controlling effect upon the load shunted across it.

In order to provide greatest range of regulation, a VR tube (or two in series) should be used with a series resistor (to effect a poorly regulated voltage source) of such a value that it will permit the VR tube to draw from 15 to 20 ma. under normal or average conditions of supply voltage and load impedance. For maximum control range the series resistance should be not less than approximately 20,000 ohms, which will necessitate a source of voltage considerably in excess of 150 volts. However, where the supply voltage is limited, good control over a *limited range* can be obtained with as little as 3000 ohms series resistance. If it takes less than 3000 ohms series resistance to make the VR tube draw 15 to 20 ma. when the VR tube is connected to the load, then the supply voltage is not high enough for proper operation.

Should the current through a VR-150 or VR-105 be allowed to exceed 30 ma., the life of the tube will be shortened. If the current falls below 5 ma., operation will become un-

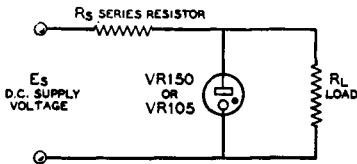

Figure 12.
STANDARD CIRCUIT FOR GLOW-DISCHARGE REGULATOR.

The regulator tube will maintain the voltage across its terminals constant to within 1 or 2 volts for moderate variations in R_L or E_S .

stable. Therefore the tube must operate within this range, and within the two extremes will maintain the voltage within 1.5 per cent. It takes a voltage excess of at least 10 or 15 per cent to "start" a VR type regulator; and to insure positive starting each time, the voltage supply should preferably exceed the regulated output voltage rating by about 20 per cent or more. This usually is automatically taken care of by the fact that if sufficient series resistance for good regulation is employed, the voltage impressed across the VR tube before the VR tube ionizes and starts passing current is quite a bit higher than the starting voltage of the tube.

When a VR tube is to be used to regulate the voltage applied to a circuit drawing less than 15 ma. normal or average current, the simplest method of adjusting the series resistance is to remove the load and vary the series resistor until the VR tube draws exactly 30 ma. Then connect the load, and that is all

there is to it. This method is particularly recommended when the load is a heater type vacuum tube, which may not draw current for several seconds after the power supply is turned on. Under these conditions the current through the VR tube will never greatly exceed 30 ma. even when it is running unloaded (while the heater tube is warming up and the power supply rectifier has already reached operating temperature).

Figure 12 illustrates the standard glow discharge regulator tube circuit. The tube will maintain the voltage across R_L constant to within 1 or 2 volts for moderate variations in R_L or E_S .

Voltage Regulated Power Supplies. When it is desired to stabilize the potential across a circuit drawing more than a few milliamperes, it is advisable to use a voltage regulated power supply of the type shown in figure 13 rather than glow discharge type tubes. The power pack illustrated will deliver up to 300 volts of well-regulated voltage, the output voltage holding within one volt for variations in line voltage or load resistance of 25 per cent.

The maximum current that may be drawn from the supply without detrimentally affecting the regulation is determined by the desired output voltage, the latter being adjustable by variation of R_3 . At 200 volts the output voltage is constant up to 100 ma., the maximum current which the 2A3 and power transformer will stand. At 300 volts, the maximum usable output voltage, the useful range is from 0 to 50 ma. At the latter

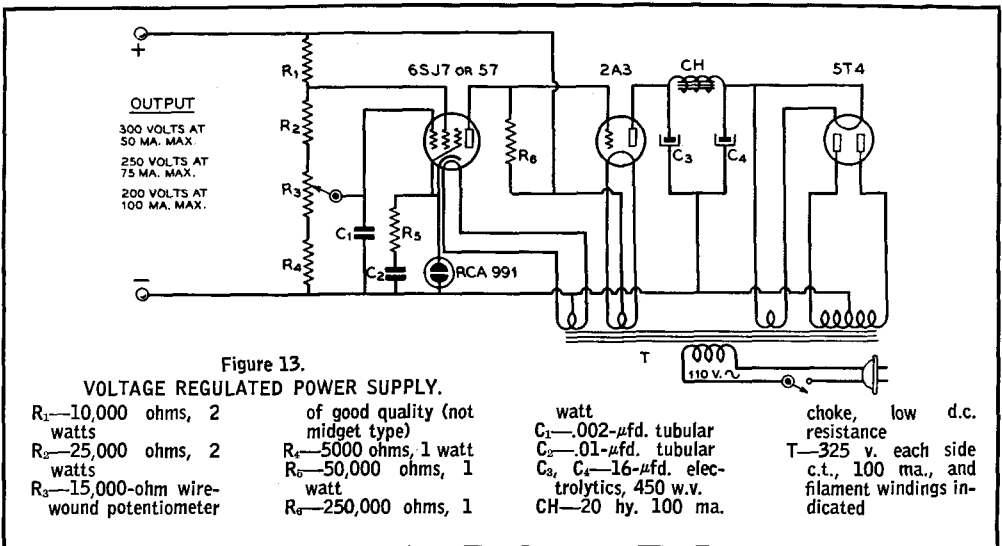

Figure 13.
VOLTAGE REGULATED POWER SUPPLY.

- R_1 —10,000 ohms, 2 watts
- R_2 —25,000 ohms, 2 watts
- R_3 —15,000-ohm wire-wound potentiometer
- R_4 —5000 ohms, 1 watt
- R_5 —50,000 ohms, 1 watt
- R_6 —250,000 ohms, 1 watt

- C_1 —0.002- μ fd. tubular
- C_2 —0.01- μ fd. tubular
- C_3, C_4 —16- μ fd. electrolytics, 450 w.v.
- CH—20 hy. 100 ma.

- choke, low d.c. resistance
- T—325 v. each side c.t., 100 ma., and filament windings indicated

voltage the regulator begins to lose control when more than 50 ma. is drawn from the supply.

The system works by virtue of the fact that the 2A3 acts as a variable series resistance or loss, and is controlled by a regulator tube much in the manner of a.v.c. circuits or inverse feedback as used in radio receivers and a.f. amplifiers. The 6SJ7 amplifier controls the bias on the 2A3, which in turn controls the resistance of the 2A3, which in turn controls the output voltage, which in turn controls the plate current of the 6SJ7, thus completing the cycle of regulation. It is readily apparent that under these conditions any change in the output voltage will tend to "resist itself," much as the a.v.c. system of a receiver resists any change in signal strength delivered to the detector.

Because it is necessary that there always be a moderate voltage drop through the 2A3 in order for it to have proper control, the rest of the power supply is designed to deliver as much output voltage as possible considering the r.m.s. voltage of the b.c.l. type power transformer. This calls for a low resistance full-wave rectifier, a high capacity input condenser, and a low d.c. resistance filter choke. A 5T4 rectifier is used in place of an 83 or other mercury vapor tube to avoid possible "hash" in any nearby receiver. This tube has lower resistance than an 80 or 5Z3.

The condenser C_1 is for the purpose of bypassing to ground any stray r.f. that might be picked up by the output voltage leads, as any r.f. reaching the grid of the 6SJ7 will

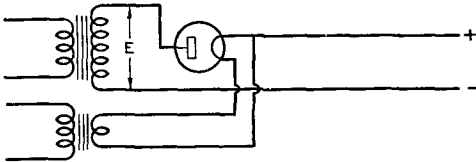

Figure 14.

SINGLE-PHASE HALF-WAVE RECTIFIER.

The output from this type rectifier is not easily filtered except where very little current is drawn (assuming 25 to 60 cycle supply).

Figure 15.

SINGLE-PHASE FULL-WAVE RECTIFIER.

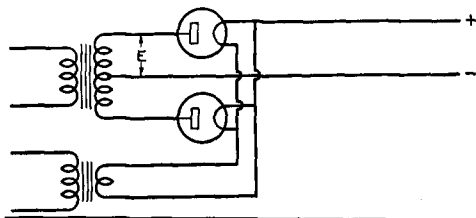

have an adverse effect upon the regulation. The resistor R_5 and condenser C_2 are for the purpose of suppressing possible oscillation of the 991 neon regulator.

It should be noted that the power transformer must have either two 2.5 volt windings or else a 6.3 volt winding and a 2.5 volt winding in addition to the usual 5 volt rectifier winding. The winding that supplies the 6SJ7 or 57 may be used to supply filament current to other equipment, but the 2.5 volt 2A3 winding must not be used to supply other tubes.

This type of supply is not suited for use as a bias pack. The presence of grid (reverse) current makes a different circuit necessary. Such a regulated bias pack is described under Class C Grid Modulation in Chapter 8.

Rectifier Circuits

The three types of rectifier circuits for single-phase a.c. line supply consist of a half-wave rectifier, as shown in figure 14, a full-wave rectifier as shown in figure 15 and a bridge rectifier circuit as shown in figure 16.

Three-phase circuits can be connected for half-wave rectification, as shown in figure 17,

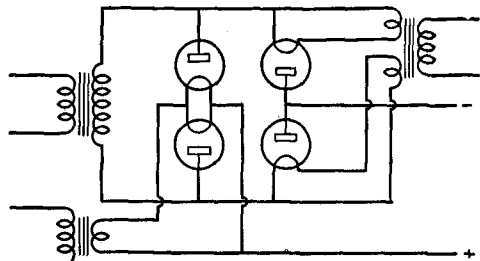
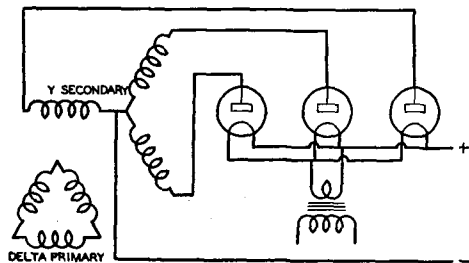

Figure 16.
BRIDGE CIRCUIT.

**Figure 17.
HALF-WAVE THREE-PHASE RECTIFIER.**

The output of this rectifier has a d.c. component and a higher ripple frequency (3 times supply frequency), and therefore is easier to filter than a single-phase full-wave rectifier.



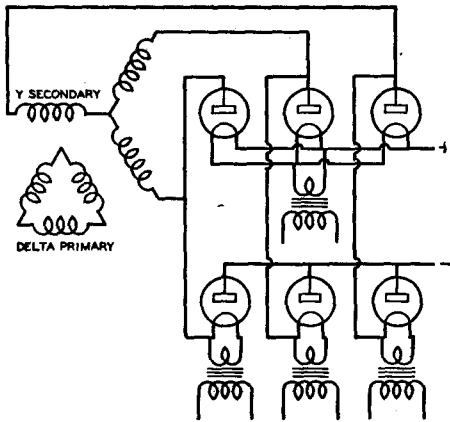

Figure 18.

FULL-WAVE THREE-PHASE RECTIFIER.

Even with no filter the output of this rectifier will have a high percentage of d.c. A simple filter will suppress the small amount of ripple, because of the high ripple frequency (6 times supply frequency).

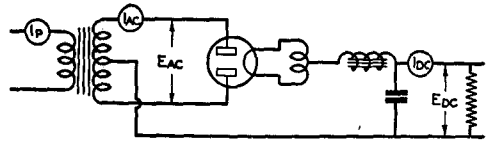

Figure 19.

FULL-WAVE RECTIFIER—CHOKE INPUT.

$E_{DC} - 435 \text{ v.}$ $E_{AC} - 1100 \text{ v.}$
 $I_{DC} - 100 \text{ ma.}$ $I_{AC} - 71 \text{ ma.}$
 $I_{PRI} - 0.6 \text{ a.}$

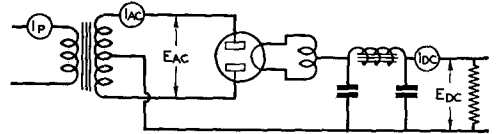

Figure 20.

FULL-WAVE RECTIFIER—CONDENSER INPUT.

$E_{DC} - 675 \text{ v.}$ $E_{AC} - 1100 \text{ v.}$
 $I_{DC} - 100 \text{ ma.}$ $I_{AC} - 103 \text{ ma.}$
 $I_{PRI} - 0.9 \text{ a.}$

or for full-wave rectification as shown in figure 18.

The most popular circuits are those shown in figures 15 and 16. The maximum transformer voltage of the high-voltage secondary, d.c. output voltage for choke-input filter, and maximum direct load current are shown in the accompanying table in terms of rectifier tube peak ratings. These peak ratings are listed in a separate table for a few commonly used rectifier tubes.

As an example, suppose type 866-A rectifier tubes are used as in figure 15: The maximum transformer voltage E across each side of the center tap is 0.35 times 10,000 or 3,500 volts. The d.c. voltage at the input to the filter (choke input) is 3,500 times 0.9 or 3,150 volts. The maximum advisable d.c. output current is 0.66 times the peak plate current of 1.0 ampere or 660 milliamperes.

These are the maximum voltages and currents which can be used without exceeding the ratings of the rectifier tubes. The actual

d.c. voltage at the output of the filter will depend upon the d.c. resistance of the filter, and can be found by subtracting the IR drop across the filter chokes from the value of 0.9 times the transformer voltage E . This does not take into consideration the voltage drop in the power transformer and rectifier tubes. The voltage drop across a mercury vapor rectifier tube is always between 10 and 15 volts. However, the voltage drop across high-vacuum rectifier tubes can be many times greater.

The power supply circuits illustrated in figures 19 to 22 represent commonly-used connections for power transformers. The values of d.c. output voltage are indicated in each case for a load current of 100 ma. The transformer secondary potential is 1,100 volts. The interesting figures in connection with each circuit are those of the primary winding current.

The circuit in figure 22 should never be used unless the load current is very low. Manufacturers generally rate their transformers in terms of secondary r.m.s. voltage

FIGURE NO.	TRANSFORMER VOLTS MAX. "E"	D.C. OUTPUT VOLTS AT INPUT TO FILTER	D.C. OUTPUT CURRENT IN AMPERES
15	.35 x Inv. Pk. Vtg.	.9 x E	.66 x Pk. Plate
16	.7 x Inv. Pk. Vtg.	.9 x E	.66 x Pk. Plate
17	.43 x Inv. Pk. Vtg.	1.12 x E	.83 x Pk. Plate
18	.43 x Inv. Pk. Vtg.	2.25 x E	1.0 x Pk. Plate

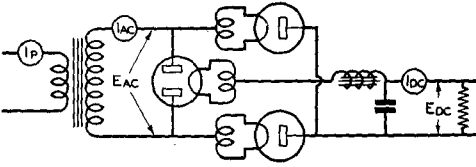

Figure 21.
BRIDGE RECTIFIER—CHOKe INPUT.
 E_{DC} — 860 v. E_{AC} — 1100 v.
 I_{DC} — 100 ma. I_{AC} — 96 ma.
 I_{PRI} — 1.1 a.

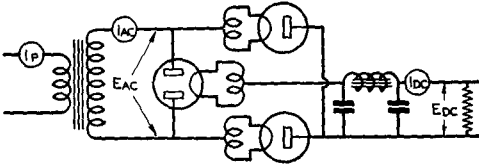

Figure 22.
BRIDGE RECTIFIER—CONDENSER INPUT.
 E_{DC} — 1200 v. E_{AC} — 1100 v.
 I_{DC} — 100 ma. I_{AC} — 148 ma.
 I_{PRI} — 1.65 a.

and the maximum d.c. load current which can be taken from a choke input filter circuit such as shown in figure 19. In order to prevent overload of the power transformer in figure 22, the load current must be reduced to less than one third of the value which can be drawn from the circuit in figure 19. The load which can be drawn from the circuit in figure 21 without overload to the power transformer is approximately 50 per cent of that for the circuit in figure 19. The permissible direct load current in figure 20 would only be two-thirds as much as for figure 19, for a given transformer size.

Mercury Vapor Rectifier Tubes. When new or long-unused high-voltage rectifier tubes of the mercury vapor type are first placed in service, the filaments should be operated at normal temperature for approximately 20 minutes before plate voltage is applied, in order to remove all traces of mercury from the cathode. After this preliminary operation, plate voltage can be applied within 20 to 30 seconds of the time the filaments are turned on each time the power supply is used. If plate voltage is applied before the filament is brought to full temperature, active material may be knocked off the oxide-coated filament and the life of the tube will be greatly shortened.

Small r.f. chokes must sometimes be connected in series with the plate leads of mercury vapor rectifier tubes in order to prevent

TUBE TYPE	PEAK INV. VOLTS	PEAK PLATE CURRENT (AMP.)
66 Jr.	2,500	.4
82	1,400	.20 } per
83	1,400	.40 } sect.
66	7,500	1.0
66A	10,000	1.0
249-B	10,000	1.5
72	7,500	5.0
72A	10,000	5.0
869	20,000	5.0
KY-21	11,000	3.0 (grid)
RX-21	11,000	3.0

the generation of radio-frequency hash. These r.f. chokes must have sufficiently heavy wire to carry the load current and enough inductance to attenuate the r.f. parasitic noise current from flowing into the filter supply leads and radiating into nearby receivers.

Small resistors or small iron-core choke coils should be connected in series with each plate lead of a mercury-vapor rectifier tube when used in circuits such as those shown in figure 23.

These resistors tend to prevent one plate from carrying the major portion of the current. *High-vacuum* type rectifiers which are connected in parallel do not require these resistors or chokes.

Bias Voltage Power Supplies. Power packs to supply negative grid voltage for radio or audio amplifiers differ from plate supplies only in that the positive and negative connections are reversed; the positive terminal of a C-bias supply is connected to ground. The filter chokes are usually connected in se-

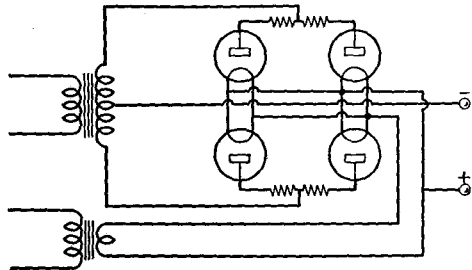

Figure 23.
PARALLEL OPERATION OF GASE-TUBE RECTIFIERS.

Small, center-tapped resistors or iron core chokes are used to make the current divide evenly. If not used, one rectifier of each parallel pair tends to take the whole load. 100 ohms or 1 Ω , center tapped, is satisfactory for each equalizer.

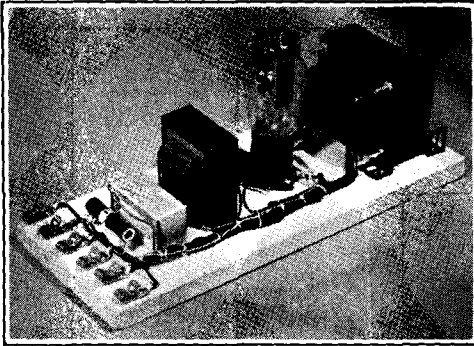

Figure 24.

TYPICAL 300-350 VOLT POWER SUPPLY:

This type of power pack ordinarily utilizes a power transformer having from 325 to 350 volts each side of c.t. with integral filament windings, and a brute force or pi type filter consisting of a single choke and dual 8- μ fd. electrolytic condenser. The rectifier is usually an 80 or 5Z3. Such packs commonly deliver from 50 to 150 ma., depending upon the ratings of the transformer and choke, and are most commonly used with receivers, a.f. amplifiers and drivers, and low power exciter stages. They are also used as bias packs, in which case a very low resistance bleeder is used, adjustable taps being provided so that the bleeder can be used as a voltage divider.

ries with the hot (ungrounded) lead, which in this case is the *negative lead*.

The bias voltage supply for a linear r.f. amplifier or class-B audio amplifier must have a very low resistance bleeder. The bleeder should be chosen so that the normal bleeder current is at least 8 times the *peak* grid current of the class B modulator or linear r.f. amplifier. If this condition is not met, the bias pack will act somewhat as a grid leak and the bias on the tubes will rise excessively under modulation.

High μ tubes require so little bias and draw so much grid current for class B operation (either r.f. or a.f.) that battery bias is ordinarily employed. It is inadvisable to use a bias pack for this purpose unless the required bias voltage is more than 90 volts.

When a pack having a tapped bleeder is used for this type of service, the tap on the

bleeder should be by-passed for voice frequencies even though the pack already has a large filter condenser across the outside terminals of the bleeder.

High efficiency grid modulation also requires a low resistance source of bias, though the bias voltage required is usually several times as great as for a class B stage using tubes of similar power. For this reason bias for this type of amplifier is more commonly obtained from a regulated bias pack rather than from a conventional pack utilizing a very low resistance bleeder in order to comply with the requirement of low resistance in the bias supply. Such a regulated bias pack is described in chapter 8 under High Efficiency Grid Modulation.

Bias Pack Considerations. It should be borne in mind that when a power supply is used "inverted" in order to provide bias to a stage drawing grid current, the grid current flows in the *same direction as the bleeder current*. This means that the grid current does not flow through the power pack as when a pack is used to supply plate voltage, but rather through the bleeder. The transformer and chokes in the bias pack actually have less work to do when the biased stage is drawing grid current, because the greater the grid current flowing through the bleeder the greater the voltage drop across it and the less current the bias pack supplies to the bleeder. In fact, if the grid current is great enough and the bleeder resistor high enough, the voltage developed across the bleeder will be greater than the maximum voltage which the power pack can deliver, and hence the power pack will be delivering no current to the bleeder. Under these conditions it is quite possible for the voltage to exceed the voltage rating of the bias pack filter condensers.

Bear in mind that the bleeder always acts as a grid leak when grid current is flowing, and while the effect can be minimized by making the resistance quite low, all grid current *must*

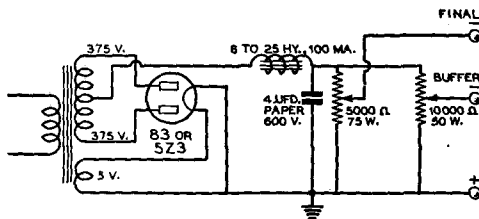

Figure 25.

BIAS PACK FOR C.W. OR PLATE MODULATED TRANSMITTER.

This pack will deliver up to 250 volts of protective bias to the various stages of a high power phone or c.w. transmitter. A large safety factor in the filter condenser is provided to permit using the full output of the pack for bias as would be the case with crystal keying of high power using medium μ tubes and running heavy grid current. The power transformer should be of about 75 ma. rating. This type of bias pack does not have good regulation, and should not be used with class B linear or class B audio stages; such applications require a very low resistance bleeder. To bias a grid modulated amplifier, another section of filter should be added.

flow through the bleeder, as it cannot flow back through the bias pack.

Class C amplifiers, both c.w. and plate modulated, require high grid current and considerably more than cutoff bias, the bias sometimes being as high as 4 or 5 times cutoff. To protect the tubes against excitation failure, it is desirable that fixed bias sufficient to limit the plate current to a safe value be used. This is normally the amount of bias that would be used on the same tubes at the same plate voltage in a class B modulator. It is best practice to obtain only this amount of bias from a bias pack, the additional required amount being obtained from a variable grid leak which is adjusted for correct bias and grid current while the stage is running under normal conditions.

This condition is such that the voltage divider tap on the bias pack will be delivering only a portion of the full bias pack voltage when the biased stage is inoperative. Then, when grid current flows to the biased stage, there is no danger of the voltage rising to dangerously high values across the filter condensers in the bias pack.

A bias power supply for providing "protective bias" to the r.f. stages of a medium-power radio transmitter is shown in figure 25.

Two bleeder resistors with slider adjustments provide any desired value of negative grid bias for the r.f. amplifiers. The location of the slider on the resistors should be determined experimentally with the amplifier in operation, since the direct grid current of the

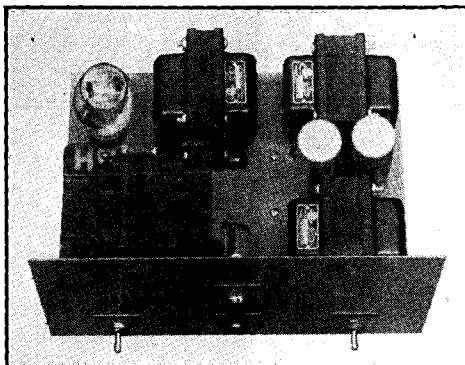

Figure 26.

TYPICAL 500-600 VOLT POWER SUPPLY.

Power supplies such as this are commonly used to feed low power r.f. stages, modulators, etc. The power transformer is generally rated at from 600 to 750 volts each side of c.t. at from 150 to 250 ma. and has no filament windings. An 83 or 5Z3 and swinging choke input filter having 600-volt oil-filled paper condensers are ordinarily used. Round can condensers of this type are usually less expensive than equivalent ones in square cans.

r.f. amplifier itself will affect the voltage across the bias supply taps. The circuit illustrated is practically free from reaction between buffer and final amplifier bias.

Transmitter Power Input Control

In the interests of interference reduction, one should run only sufficient power input to

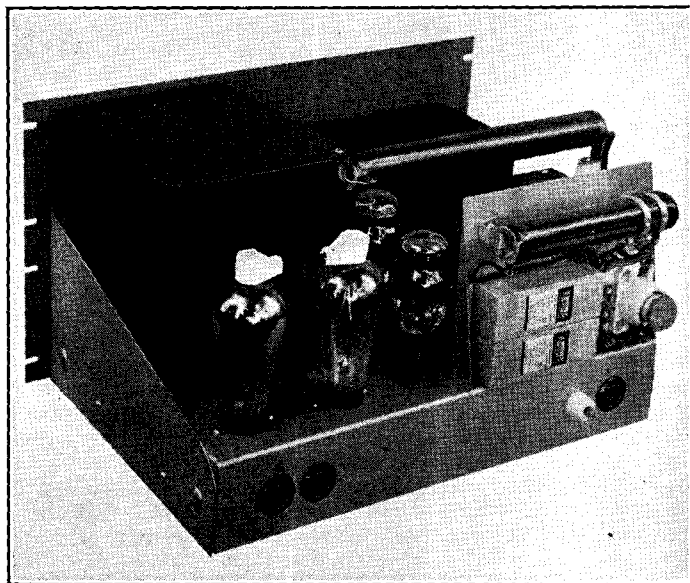

Figure 27.

POWER SUPPLY FOR RELAY RACK MOUNTING.

Illustrating well-designed dual power pack for relay rack mounting. Observe the fuse, bleeders, and the feedthrough terminal for the high voltage connection. This unit delivers 1500 and 600 volts. Note that the heaviest components are mounted towards the front panel to minimize the strain on panel and chassis.

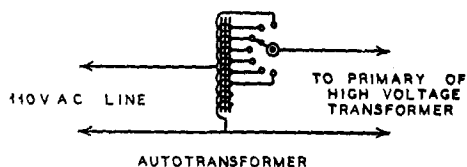

Figure 28.

AUTOTRANSFORMER VOLTAGE CONTROL.

a radio transmitter to maintain satisfactory communication. The power input to the final r.f. amplifier of a c.w. transmitter can be controlled over a very wide range by means of an *autotransformer*, connected as in figure 28.

The a.c. voltage can be varied from a few volts up to 130 volts, by means of a relatively small autotransformer. This a.c. voltage should be applied only to the high-voltage power transformer which supplies plate power to the final r.f. amplifier.

Convenient adjustment of input to a phone transmitter other than of the plate modulated type is a more difficult problem. Input to a plate-modulated transmitter can be varied the same as for a c.w. transmitter without danger of overmodulating the reduced input if the primary voltage for the plate transformer that feeds the modulators is fed from the same tap on the autotransformer as the plate transformer for the final amplifier. This assumes the modulators are of the "zero bias" type. If one power supply is used for both, the problem is further simplified.

Reducing the power of a grid-modulated final amplifier is more of a problem. The best method for reducing power is to reduce the r.f. excitation *and* audio gain together, without disturbing the bias or plate voltage or antenna coupling adjustment.

Those using linear r.f. amplifiers can either incorporate a switching arrangement for throwing the antenna over to the low-level modulated stage and thus reduce power about 10 db, or else merely reduce excitation to the linear amplifier *without* disturbing the a.f. gain control.

Overload Protection

To protect the tubes in a medium or high power final amplifier in the event of excitation failure, any one of several courses is satisfactory. If very high μ tubes of the "zero bias" type commonly used as modulators are used in the class C amplifier, no protection is necessary if the tubes are run within their voltage rating. However, such tubes ordinarily require somewhat more excitation than an equivalent medium high μ tube. Thus, an

811 requires more excitation than an 812, nearly twice as much when plate modulated.

Safety bias from a bias pack or batteries invariably is used on the various stages in a c.w. transmitter which is oscillator keyed. However, when the final amplifier is keyed, or for telephony, such bias is not required from the standpoint of keying, but simply to protect the tubes from excessive dissipation in the event of accidental excitation failure. Other means of protecting the tubes against such possibility are as follows.

Overload relays, which can be adjusted to trip and stay open at any desired amount of plate current, can be used to open the primary of the plate transformer. However, such relays are rather expensive as compared to simple relays of the s.p.s.t. type, and usually cost as much as a bias pack.

A small instrument fuse (*Littelfuse*) of appropriate current rating can be placed in the *center tap* lead to the amplifier stage (the grid leak going to ground or B minus side of the fuse). These fuses cost but 10c, and while rated at only 250 volts, will work satisfactorily at high plate voltage when placed in the center tap lead and not in the B plus or B minus lead. The current rating should be such that the fuse does not blow immediately when the plate current is excessive, but does blow before the tubes become hot enough to be damaged. The correct value to use can be determined by blowing one or two fuses experimentally by detuning the amplifier or otherwise making it draw a momentarily large plate current.

These methods of protection (overload relay or fuse) are satisfactory only when the amplifier tube draws *considerably more current at zero bias than it does under normal operating conditions*. This generally will apply with tubes having a μ of 30 or less. It is obvious that if the tube draws about the same plate current at zero bias and no excitation as it does under normal conditions, the dissipation can be excessive without the fuse or overload relay being actuated. By looking up the characteristic curves on a tube it is possible to ascertain if it draws appreciably more plate current at zero bias and no excitation than it does under normal operating conditions.

Perhaps the best type of protection is obtained by means of an inexpensive s.p.s.t. relay which is actuated by the grid current to the final stage. The relay winding should be such that the contacts close at about half normal grid current, and the winding should be capable of handling somewhat more than normal grid current without damage. Suit-

able relays are these sold by several manufacturers for less than \$1.75, and a suitable winding can be had for most any grid current from 25 to 200 ma. by the choice of 6, 12, and 24 volt d.c. windings available.

The relay contacts may be used to short out a cathode bias resistor. In this way, the amplifier has cathode bias until excitation is applied, then the relay closes and shorts out the cathode bias. Used in this manner, the relay contacts have little work to do. Just sufficient cathode bias should be used to keep the plate dissipation from exceeding the rated maximum when excitation fails. Normally about 750 ohms will be about right for one tube and 400 ohms for two tubes.

If the relay contacts are sufficiently heavy, they may be used to break the primary of the high voltage plate transformer feeding the final amplifier. Because of the inductive "kick", rather heavy contacts will be required in this service when running high power.

Because the cathode bias resistor is shorted out when normal plate current is being drawn, the resistor need not have a high dissipation rating. A 10-watt resistor will be large enough for a 250-watt rig. A typical circuit using this arrangement is shown in figure 29.

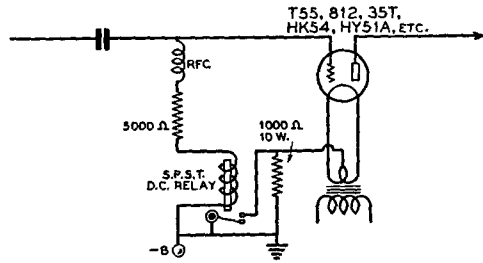

Figure 29.

IMPROVED CATHODE BIAS.

At the cost of a small, inexpensive relay the protection of cathode bias may be obtained with none of the disadvantages of the latter. When excitation is applied, the cathode bias resistor is shorted out. This circuit shows a typical application. The relay should close at about half normal grid current and be capable of standing the maximum grid current.

core, and reconverted into electrical energy in the secondary. The amount of core material determines quite definitely the power that any transformer will handle.

Transformer cores are often designed so that if the losses per cubic inch of core material are determined, these losses can be used as a basis for calculating the rating of the transformer. These losses exist in watts, and are divided between the eddy current loss and the hysteresis loss. The eddy current loss is the loss due to the lines of force moving across the core, just as if it were a conductor, and setting up currents in it.

Induced currents of this type are very undesirable and they are merely wasted in heating the core, which then tends to heat the windings, increase the resistance of the coils and reduce the overall power handling ability of the transformer. To reduce such losses, transformer cores are made of thin sheets, usually about no. 29 gauge. These sheets are insulated from each other by a coat of thin varnish, shellac or japan, or by the iron-oxide scale which forms on the sheets during the manufacturing process and which forms a good insulator between sheets.

Hysteresis. The magnetic flux in the core lags behind the magnetizing force that produces it, which is, of course, the primary supply. Because all transformers operate on alternating current, the core is subjected to continuous magnetizing and demagnetizing force, due to the alternating effect of the a.c. field. This *hysteresis* (meaning "to lag") heats the iron, due to molecular friction caused by the iron molecules re-orienting themselves as the direction of the magnetizing flux changes.

Transformer Design

A common problem in radio and allied work is to determine how a transformer can be built to supply certain power requirements for a particular application, or how to calculate the windings needed to fit a certain transformer core which is already on hand. These problems can be solved by a small amount of calculation.

The most important factor in determining the size of any transformer is the amount of core material available. The electrical rating, as well as the physical size, is determined almost entirely by the size of the core. The core material is also important. The present practice is to use high-grade silicon-steel sheet. It will be assumed that this type of material is to be employed in all construction herein described. Soft sheet-iron or stovepipe iron is sometimes substituted, but transformers made from such materials will have about 50 to 60 per cent of the power rating, pound for pound of core, as those made from silicon-steel.

The Core. The core size determines the performance of a transformer because the entire energy circulating in the transformer (except small amounts of energy dissipated in resistance losses in the primary) must be transformed from electrical energy in the primary winding to magnetic energy in the

Copper Wire Table

Gauge No. B. & S.	Diam. in Mile ¹	Circular Mil Area	Turns per Linear Inch ²				Turns per Square Inch ²				Feet per Lb.		Ohms per 1000 ft. 25° C.	Correct Capacity at 1500 C.M. per Amp. ³	Diam. in mm.
			Enamel	S.S.C.	D.S.C. or S.C.C.	D.C.C.	S.C.C.	Enamel	D.C.C.	Bare	D.C.C.				
1	289.3	82690	—	—	—	—	—	—	—	—	3.947	—	1264	55.7	7.348
2	257.6	66370	—	—	—	—	—	—	—	—	4.977	—	1593	44.1	6.544
3	229.4	52640	—	—	—	—	—	—	—	—	6.276	—	2009	35.0	5.827
4	204.3	41740	—	—	—	—	—	—	—	—	7.914	—	2533	27.7	5.189
5	181.9	33100	—	—	—	—	—	—	—	—	9.980	—	3195	22.0	4.621
6	162.0	26250	—	—	—	—	—	—	—	—	12.58	—	4028	17.5	4.115
7	144.3	20820	—	—	—	—	—	—	—	—	15.87	—	5080	13.8	3.665
8	128.5	16510	7.6	—	7.4	7.1	—	—	—	—	20.01	19.6	6405	11.0	3.264
9	114.4	13090	8.6	—	8.2	7.8	—	—	—	—	25.23	24.6	8077	8.7	2.906
10	101.9	10380	9.6	—	9.3	8.9	87.5	84.8	80.0	—	31.82	30.9	1.018	6.9	2.588
11	90.74	8234	10.7	—	10.3	9.8	110	105	97.5	—	40.12	38.8	1.284	5.5	2.305
12	80.81	6530	12.0	—	11.5	10.9	136	131	121	—	50.59	48.9	1.619	4.4	2.053
13	71.96	5178	13.5	—	12.8	12.0	170	162	150	—	63.80	61.5	2.042	3.5	1.828
14	64.08	4107	15.0	—	14.2	13.8	211	198	183	—	80.44	77.3	2.575	2.7	1.628
15	57.07	3257	16.8	—	15.8	14.7	262	250	223	—	101.4	97.3	3.247	2.2	1.450
16	50.82	2583	18.9	18.9	17.9	16.4	321	306	271	—	127.9	119	4.094	1.7	1.291
17	45.26	2048	21.2	21.2	19.9	18.1	397	372	329	—	161.3	150	5.163	1.3	1.150
18	40.30	1624	23.6	23.6	22.0	19.8	493	454	399	—	203.4	188	6.510	1.1	1.024
19	35.89	1288	26.4	26.4	24.4	21.8	592	553	479	—	256.5	237	8.210	.86	.9116
20	31.96	1022	29.4	29.4	27.0	23.8	775	725	625	—	323.4	298	10.35	.68	.8118
21	28.46	810.1	33.1	32.7	29.8	26.0	940	895	754	—	407.8	370	13.05	.54	.7230
22	25.35	642.4	37.0	36.5	34.1	30.0	1150	1070	910	—	514.2	461	16.46	.43	.6438
23	22.57	509.5	41.3	40.6	37.6	31.6	1400	1300	1080	—	648.4	584	20.76	.34	.5733
24	20.10	404.0	46.3	45.3	41.5	35.6	1700	1570	1260	—	817.7	745	26.17	.27	.5106
25	17.90	320.4	51.7	50.4	45.6	38.6	2060	1910	1510	—	1031	903	33.00	.21	.4547
26	15.94	254.1	58.0	55.6	50.2	41.8	2500	2300	1750	—	1300	1118	41.62	.17	.4049
27	14.20	201.5	64.9	61.5	55.0	45.0	3030	2780	2020	—	1639	1422	52.48	.13	.3606
28	12.64	159.8	72.7	68.6	60.2	48.5	3670	3350	2310	—	2067	1759	66.17	.11	.3211
29	11.26	126.7	81.6	74.8	65.4	51.8	4300	3900	2700	—	2607	2207	83.44	.084	.2859
30	10.03	100.5	90.5	83.3	71.5	55.5	5040	4660	3020	—	3287	2534	105.2	.067	.2546
31	8.928	79.70	101.	92.0	77.5	59.2	5920	5280	—	—	4145	2768	132.7	.053	.2268
32	7.950	63.21	113.	101.	83.6	62.6	7060	6250	—	—	5227	3137	167.3	.042	.2019
33	7.080	50.13	127.	110.	90.3	66.3	8120	7360	—	—	6591	4697	211.0	.033	.1798
34	6.305	39.75	143.	120.	97.0	70.0	9600	8310	—	—	8310	6168	266.0	.026	.1601
35	5.615	31.52	158.	132.	104.	73.5	10900	8700	—	—	10480	6737	335.0	.021	.1426
36	5.000	25.00	175.	143.	111.	77.0	12200	10700	—	—	13210	7877	423.0	.017	.1270
37	4.453	19.83	198.	154.	118.	80.3	—	—	—	—	16660	9309	533.4	.013	.1131
38	3.965	15.72	224.	166.	126.	83.6	—	—	—	—	21010	10666	672.6	.010	.1007
39	3.531	12.47	248.	181.	133.	86.6	—	—	—	—	26500	11907	848.1	.008	.0897
40	3.145	9.88	282.	194.	140.	89.7	—	—	—	—	33410	14222	1069	.006	.0799

¹A mil is 1/1000 (one thousandth) of an inch.

²The figures given are approximate only, since the thickness of the insulation varies with different manufacturers.

³The current-carrying capacity at 1000 C.M. per ampere is equal to the circular-mil area (Column 3) divided by 1000.

Table courtesy P. R. Mallory & Co.

Saturation. The higher the field strength, the greater the heat produced. A condition can be reached where a further increase in magnetizing flux does not produce a corresponding increase in the flux density. This is called "saturation" and is a condition which would cause considerable heat in a core. In practice, it has been found that all core material must be operated with the magnetic flux well below the limit of saturation.

Core Losses. All core losses manifest themselves as heat and these losses are the determining factor in transformer rating. They are spoken of as "total core loss," generally used as a single figure, and for common use a core loss of from .75 watt to 2.5 watts per pound of core material can be assumed for 60 cycles. The lower figure is for the better grades of thin sheet, while the higher loss is for heavier grades.

About 1 watt per pound is a very satisfactory rating for common grades of material. This rating is also dependent on the manner in which the transformer is built and mounted and in the ease with which the heat is radiated from the core. Transformers with higher losses may be used for intermittent service.

The transformer core loss can be assumed to be from 5 to 10 per cent of the total rating for small transformers. Thus, if the core loss is known, the rating of the transformer can be easily determined. If the figure of 1 watt

per pound is assumed, the problem is further simplified. To determine the rating of the transformer, weigh the core. If, for example, the core weighs 10 pounds, the transformer will handle from 100 to 200 watts. Such a transformer core can be assumed to have about 150 watts nominal rating.

If the weighing of the core is inconvenient, the weight can be calculated from the cubic content or volume. Sheet-steel core laminations weigh approximately one-fourth pound per cubic inch.

Transformer cores are generally made of two types, shell and core. The shell-type has a center leg which accommodates the windings, and this is twice the cross-sectional areas of the side legs. The core-type is made from strips built-up into a hollow-like affair of uniform cross section. For the shell-type core, the area is taken as the square section of the center leg, in this case $2\frac{1}{4}'' \times 4\frac{1}{2}''$ and in the core-type, this area is taken as the section of 1 leg, and is also $2\frac{1}{4}'' \times 4\frac{1}{2}''$, or an actual core area in both cases of 10.1 square inches, which is large enough for a comparatively large transformer.

Turns Per Volt. To determine the number of turns for a given voltage, apply the following formula:

$$E = \frac{4.44 N B A T}{10^8}$$

Figure 30.

COMBINED MODULATOR AND POWER SUPPLY.

While ordinarily it is preferable to design a power supply as an integral, independent unit, it sometimes is desirable for reasons of limited space to construct a modulator or r.f. unit with its power supply on the same chassis. In this example a modulator and its power supply are mounted on a single chassis, thus making use of every bit of space. Also, external connecting cables are avoided, but special care must be taken to prevent hum from being picked up from the power supply by the input stage of the speech amplifier.

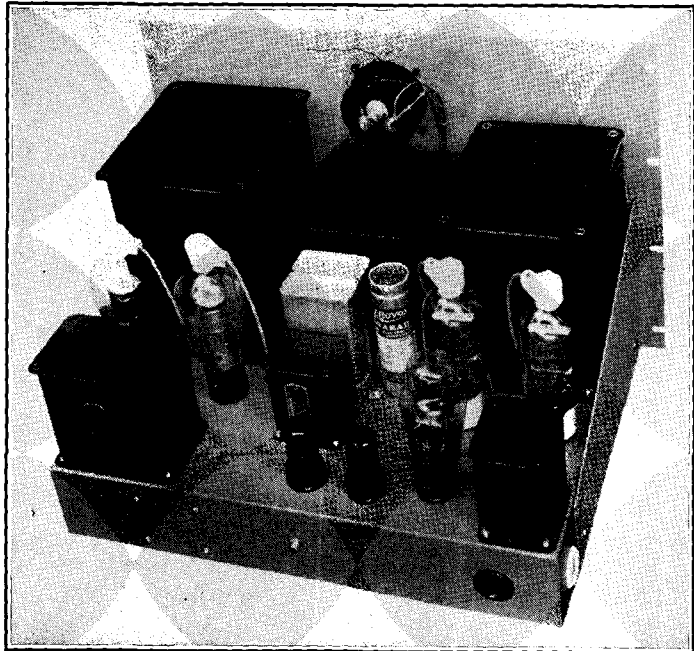

Transformer Design Chart

SECONDARY WINDINGS (Turns for Voltages Given)

WATTS	Section of Core (inches)	Area of Core (Square inches)	Primary Turns	Primary Wire Size	Turns per Volt	HIGH-VOLTAGE WINDING																	
						2.5 volts	5.0 volts	6.3 volts	7.5 volts	10 volts	250 volts	300 volts	350 volts	400 volts	450 volts	500 volts	600 volts	700 volts	800 volts	900 volts	1000 volts	1250 volts	1500 volts
10	½ x ½	.25	3500	31	32	80	160	205	240	320													
10	½ x ⅝	.31	2800	31	24.2	61	122	147	182	242													
12	½ x ¾	.37	2300	30	20.0	50	100	126	150	200													
12	⅝ x ⅝	.38	2280	30	19.6	48	96	124	147	196													
15	⅝ x ¾	.46	1875	29	16.1	42	84	105	124	161													
22	⅝ x 1	.62	1400	28	12.2	31	61	77	92	122													
20	¾ x ¾	.55	1570	28	13.6	34	68	86	102	136													
25	¾ x 1	.75	1150	27	10.0	25	50	63	75	100	2620	3150	3700	4200	4750	5250							
30	¾ x 1¼	.93	930	26	8.1	21	42	52	62	81	2100	1500	3140	3400	3800	4200							
50	¾ x 1½	1.12	770	24	6.7	17	34	43	50	67	1860	2100	2500	2840	3150	3500	4200	5000					
50	1 x 1	1.0	860	24	7.5	19	38	48	57	75	1950	2400	2700	3150	3600	3900	4700	5500					
60	1 x 1¼	1.25	690	23	6.0	15	30	38	45	60	1600	1900	2200	2500	2800	3150	3800	4400					
65	1 x 1½	1.50	575	23	5.0	13	25	32	38	50	1300	1575	1850	2100	2400	2650	3150	3700					
75	1 x 1¾	1.75	490	22	4.2	11	21	27	31	42	1100	1320	1550	1750	2000	2200	2650	3150	3800	4000	4400		
110	1 x 2	2.0	430	21	3.7	9	18	23	28	37	980	1170	1370	1550	1750	1960	2300	2750	3100	3500	3900		
105	1¼ x 1¼	1.56	550	21	4.8	12	24	31	36	48	1260	1510	1770	2050	2240	2510	3050	3500	4100	4500	5020		
100	1¼ x 1½	1.87	460	21	3.8	9	19	25	29	38	1000	1200	1400	1600	1800	2000	2400	2720	3200	3560	4000		
120	1¼ x 1¾	2.18	400	20	3.5	9	18	21	26	35	920	1100	1315	1470	1650	1840	2200	2560	2940	3300	3700	4620	5500
140	1¼ x 2	2.5	350	19	3.2	8	16	20	24	32	840	1020	1180	1340	1510	1680	2050	2350	2680	3000	3380	4200	5050
125	1½ x 1½	2.25	380	20	3.3	8	16	21	25	33	870	1040	1210	1400	1560	1730	2100	2420	2800	3120	3500	4400	5250
150	1½ x 1¾	2.64	330	18	2.9	7	14	19	22	29	760	910	1130	1220	1360	1530	1840	2100	2450	2750	3050	3800	4650
200	1½ x 2	3.0	290	17	2.42	6	12	15	18	24	630	765	890	1020	1150	1265	1522	1780	2050	2380	2350	3200	3840
300	2 x 2	4.0	215	15	1.87	5	9	12	14	19	490	590	690	780	880	980	1180	1360	1570	1760	1950	2350	2940
400	2 x 2½	5.0	175	14	1.52	4	8	10	12	15	395	470	550	640	710	790	950	1110	1265	1420	1590	1980	2400
500	2 x 3	6.0	145	13	1.26	3	6	8	9	12	330	395	455	530	595	660	790	920	1060	1200	1330	1650	2000

Where E equals the volts of the circuit; N, the cycles of the circuit; B, the number of magnetic lines per square inch of the magnetic circuit; A, the number of square inches of the magnetic circuit, and T, the number of turns.

The proper value for B, for small transformers and for ordinary grades of sheet-iron, such as are now being considered, is 75,000 for 25 cycles and 50,000 for 50 or 60 cycles.

Rewriting the above formula

$$T = \frac{E \times 10^8}{4.44 N B A}$$

and since N and B are known

$$T = \frac{10^8}{4.44 \times 60 \times 50,000} \times \frac{E}{A}$$

from which

$$T = 7.5 \times \frac{E}{A}$$

That is, for a transformer to be used on a 60-cycle circuit, the proper number of turns for the primary coil is obtained by multiplying the line voltage by 7.5 and dividing this product by the number of square inches cross section of the magnetic circuit.

On a 25-cycle circuit, the 7.5 becomes 12, and on 50 cycles it becomes 9.

Design Example. Assume a transformer core that is to be used on a 115-volt, 60-cycle

circuit for supplying power to two rectifier tubes, each of which takes 1,000 volts on the plate. The rectifier is of the full-wave type. The core measures 2½ inches x 4½ inches; hence,

$$T = \frac{7.5 \times 115}{2.25 \times 4.5} = 85 \text{ (to the nearest$$

turn), and the volts per turn equals

$$\frac{115}{85} = 1.353 \text{ which is the same for all coils.}$$

Now, the secondary coil must have two windings in series, each to give 1,000 volts, and with a middle tap. The secondary turns

$$\text{will be } \frac{2000}{1.353} = 1478 \text{ with a tap taken out at}$$

the 739th turn.

Allowing 1,500 circular mils per ampere, the primary wire should be no. 12. The size of the wire on the plate coils may be no. 22 or 24 for a 400 to 300 ma. rating.

To determine the quantity of iron to pile up for a core, it is well to consider 1 to 1.5 volts per turn as a conservative range. For trial, assume 1.25 volts. Then by transforming the first equation

$$A = 7.5 \times \frac{E}{T} \text{ or, the area required is } 7.5$$

Figure 31.
DUAL POWER SUPPLY.

In a rack-mounted power supply, which is supported from the front panel, it is advisable to place the heavy components close to the front panel to minimize the strain on the panel and chassis. Note the position of the heavy plate transformer. The chassis contains a 350-volt power supply and a 1250-volt power supply. Low voltage power supply components are to the right.

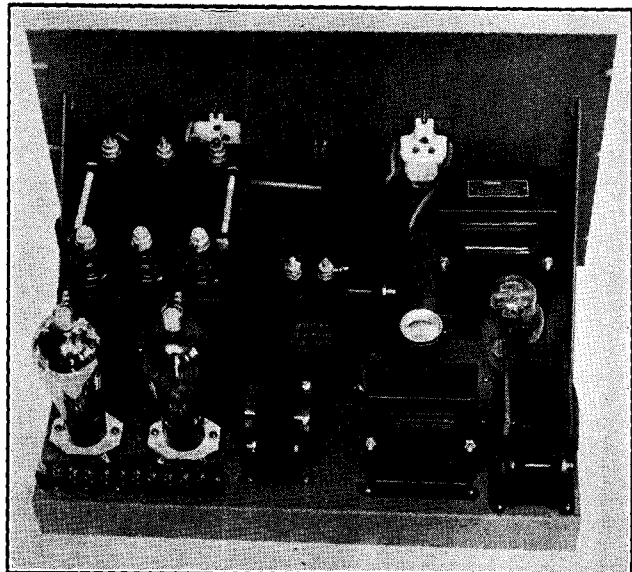

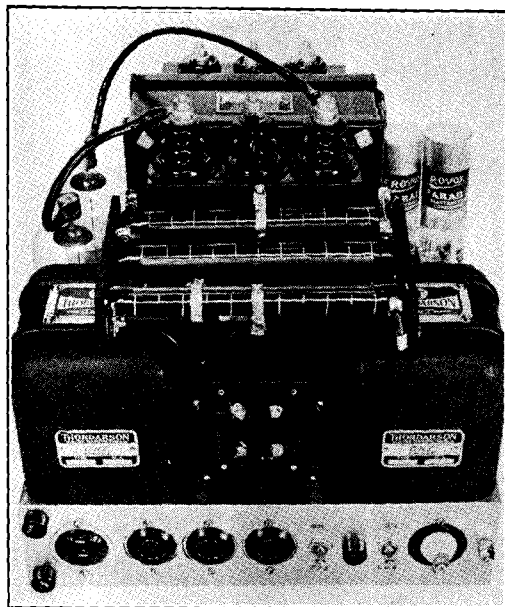

Figure 32.
ILLUSTRATING COMPACT POWER
SUPPLY CONSTRUCTION.

This dual power supply illustrates what can be crowded on a chassis when space is at a premium. Note how the heavy bleeders, which also act as voltage dividers, are mounted so as to provide free circulation of air. A pair of 866's serve as rectifier in a conventional circuit for a high voltage supply; an 83 rectifier is used in the low voltage supply.

times the volts per turn; in this case, $7.5 \times 1.25 = 9.38$ sq. in.

The magnetic cross section must be measured at right angles to the laminations that are enclosed by the coil, the center leg when the core is built up around the coil and either leg where the core is built up inside the coil, that is, between the arrows in the sketches shown on the next page.

It should be kept in mind that there is a copper or resistance loss in all transformers. This is caused by the passage of the current through the windings and is commonly spoken of as the "IR" loss. It manifests itself directly as heat and varies as the load is varied; the heavier the load, the more heat is developed.

This heat, as well as other heat losses, must be removed or the transformer will burn up. Most transformers are so arranged that both the core and windings can radiate heat into the surrounding air and thus cool themselves. Large transformers are mounted in oil for

cooling and also for the purpose of increasing the insulation factor.

In any transformer, the voltage ratio is directly proportional to the turns ratio. This means that if the transformer is to have 110-volts input and 250 turns for the primary, and if the output is to be 1,100 volts, 2,500 turns will be needed. This may be expressed as:

$$\frac{E_p}{E_s} = \frac{T_p}{T_s}$$

It is often more convenient to take the figure obtained for the primary winding and, by dividing by the supply voltage, the number of turns per volt is calculated. This accomplished, the number of turns for any given voltage can be calculated by simple multiplication.

Radio transformers are generally of small size. The matter of power factor can therefore be disregarded, more especially because they work into an almost purely resistive load. In the design of radio transformers, the power factor can be safely assumed as unity, in which case the apparent watts and the actual watts are the same. Admittedly, this is not always a correct assumption, but it will suffice for common applications.

The size of the wire to be used in any transformer depends upon the amperage to be carried. For a current of 1 ampere as a continuous load, at least 1,000 circular mils per ampere must be allowed. For transformers which have poor ventilation, or continuous heavy load service, or where price is not the first consideration, 1,500 circular mils per ampere is a preferable figure. If, for example, a transformer is rated at 100-watts primary load on 110 volts, the current will be

$$I = \frac{W}{V} = \frac{100}{110} = 0.90 \text{ amperes}$$

and if the assumption is 1,000 circular mils per ampere, it will be found that this will require $1,000 \times .90$, or 900 circular mils. The wire table on page 306 shows that no. 20 wire for 1,200 mils is entirely satisfactory. If it is desired to use 1,500 circular mils, instead of 1,000, this will require $1,500 \times .90$ or 1350 mils, which corresponds to approximately no. 19 wire. The difference seems to be small, yet it is large enough to reduce heating and to improve overall performance. Assume, for tentative design, a 600-volt, 100-ma. high-voltage secondary; a 3-ampere 5-volt secondary, and 2.5-volt 7.5-ampere secondary. Simple calculation will show a 60-watt load on the high-

voltage secondary; 15 watts on the 5-volt winding, and 16 watts on the 2.5-volt winding, a total of 91 watts. The core and copper loss is 10 watts. The wire sizes for the secondaries will be for 100-ma. current, no. 30 wire; 3 amperes at 5 volts, no. 15 wire; no. 11 wire for the 7.5-ampere secondary.

For high-voltage secondary windings, a small percentage of turns should be added to overcome the resistance of the small wire used, so that the output voltage will be as high as anticipated. The figures given in the table include this percentage which is added to the theoretical ratio and, consequently, the number of turns shown in the table can be accepted as the actual number to be wound on the core of any given transformer.

Insulation. Allowance should always be made for the insulation and size of the windings. Good insulation should be provided between the core and the windings and also between each winding and between turns. Numerous materials are satisfactory for this purpose; varnished paper or cloth, called empire, is satisfactory, although costly. Good bond paper will serve well as an insulating medium for small transformer windings.

Insulation between primary and secondary and to the core must be exceptionally good, as well as the insulation between windings. Thin mica or micanite sheet is very good. Thin fibre, commonly called fish paper, is also a good insulator; bristol board, or strong, thin cardboard may also be used. In all cases, the completed coil should be impregnated with insulating varnish, and either dried in air or baked in an oven. Common varnishes or shellac are unsatisfactory on account of the moisture content of these materials. Air-drying

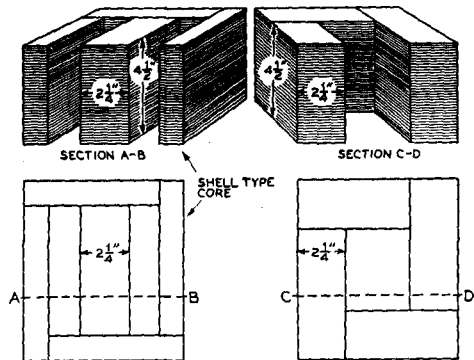

Figure 33. TYPES OF TRANSFORMER CORES.

insulating varnish is practical for all-around purposes; baking varnish may be substituted, but the fumes given off are inflammable and often explosive. Care must be exercised in the handling of this type of material. Collodion and banana oil lacquer are positively dangerous, and in the event of a short circuit or transformer burn-out, a serious fire may result.

If it is desired to wind a transformer on a given core, it is much better to calculate the actual space required for the windings, then determine whether there is enough available space on the core. If this precaution is not observed, the designer may find that only about half the turns are actually wound on the core, when the space is about three-fourths filled. From 15 to 40 per cent more space than calculated must be allowed. The winding of transformers by hand is a laborious process. Unless the builder is an experienced coil-

Choke Table for Transmitter Power Supply Units

CURRENT M.A.	WIRE SIZE	NO. TURNS	LBS. WIRE	APPROX. CORE (Area)	AIR GAP	WT. CORE
200	No. 27	2000	1.5	1 1/2" x 1 1/2"	3/32"	4 lbs.
250	No. 26	2000	1.75	1 1/2" x 2"	3/32"	5 lbs.
300	No. 25	2250	2	2" x 2"	1/8"	6 lbs.
400	No. 24	2250	3	2" x 2 1/2"	1/8"	7 lbs.
500	No. 23	2500	4	2 1/2" x 2 1/2"	1/8"	10 lbs.
750	No. 21	3000	6	2 1/2" x 3"	1/8"	14 lbs.
1000	No. 20	3000	7.5	3" x 3"	1/8"	18 lbs.

NOTES: These are approximately based on high-grade silicon steel cores with total air gaps as given. Air gaps indicated are total of all gaps.

The use of standard "E" and "I" laminations is recommended. If strips are used, and if an ordinary square core is used, the number of turns should be increased about 25%. Choke coils built as per the above table will have an approximate inductance of 10 to 15 henrys. Because considerable differences occur due to winding variations, allowable flux densities of cores, etc., the exact inductance cannot be stated; these chokes will, however, give satisfactory service in radio transmitter power supply systems.

The wire used is based on 1000 circular mils per ampere; this will cause some heating on long runs, and if the chokes are to be used continuously, as in a radiotelephone station in continuous service, it is good practice to use the next size larger choke shown for such loads.

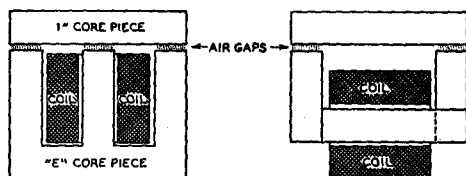

Figure 34.

Two types of choke coil construction. The air gap is approximately $\frac{1}{32}$ inch. The gap may be filled with non-magnetic material, such as brass, bakelite, etc.

winder, there is every chance that a sizable portion of the space will be used up by insulation, etc., not sufficient space remaining for the winding. Calculate the cubical space needed for the total number of turns, and allow from 15 to 40 per cent additional space in the core window. Thereby much time and labor will be saved.

Filter Choke Considerations

A choke is a coil of high inductance. It offers an extremely high impedance to alternating current, or to current which is substantially alternating, such as pulsating d.c. delivered at the output of a rectifier.

Choke coils are used in power supplies as part of the complete filter system in order to produce an effectively-pure direct current from the pulsating current source, that is, from the rectifier. The wire size of the choke must be such that the current flowing through it does not cause an appreciable voltage drop due to the ohmic resistance of the choke; at the same time, sufficient inductance must be maintained to provide ample smoothing of the rectified current.

Smoothing Chokes. The function of a smoothing choke is to discriminate as much as possible between the a.c. ripple which is present and the desired d.c. that is to be delivered to the output. Its air gap should be large enough so that the inductance of the choke

does not vary materially over the normal range of load current drawn from the power supply, but no larger than necessary to give maximum inductance at full current rating.

Swinging Chokes. In certain radio circuits the power drawn by a vacuum tube amplifier can vary widely. Class-B audio amplifiers are good examples of this type of amplifier. The plate current drawn by a class-B audio amplifier can vary 1000 per cent or more. It is desirable to keep the d.c. output voltage applied to the plate of the amplifier as constant as possible and the voltage should be independent of the current drawn from the power supply. The output voltage from a given power supply is always higher with a condenser input filter than with a choke-type input filter. When the input choke is of the *swinging* variety, it means that the inductance of the choke varies widely with the load current drawn from the power supply, due to the fact that high initial inductance is obtained by utilizing a "butt" gap, or none at all as in a transformer core.

Choke Design and Construction

A choke is made up from a silicon-steel core which consists of a number of thin sheets of steel, similar to a transformer core, but wound with only a single winding. The size of the core and the number of turns of wire, together with the air gap which must be provided to prevent the core from saturating, are factors which determine the inductance of a choke. The relative sizes of the core and coil determine the amount of d.c. which can flow through the choke without reducing the inductance to an undesirable low value due to magnetization.

The same core material which is used in ordinary radio power transformers or from those which are burned out, is satisfactory for all general purposes.

In construction, the choke winding must be insulated from the core with a sufficient quantity of insulating material so that the highest peak voltages which are to be experienced in service will not rupture the insulation.

CHAPTER SIXTEEN

Transmitter Construction

With one exception, the units shown in this chapter are complete transmitters, including modulator and power supply. The complete transmitters are shown for the benefit of those who prefer to construct a whole transmitter from a tried and proven circuit which has been engineered from the standpoint of an integral unit rather than attempt to work out an individual design from the exciter, amplifier, power supply and modulator units shown elsewhere in this book.

All of the complete transmitters shown in this chapter are radiophone transmitters, because it is a simple matter to omit the modulation equipment if phone operation is not desired. Also shown in this chapter is a 250-watt r.f. unit which requires a high voltage power supply to be considered a transmitter; it is shown in this chapter instead of in Chapter 12 because it is somewhat large to be considered as an exciter for amateur work, and would always be used with suitable power supplies to feed an antenna rather than a high power amplifier. No amplifier using modern tubes running at one kilowatt input requires as much as 250 watts excitation, even for plate modulated service.

40-WATT TRANSMITTER-EXCITER

The unit illustrated in figures 1, 2, 3 and 5 is intended to serve as a complete phone-c.w. transmitter or as an r.f. and audio driver for a higher power final amplifier and modulator. The transmitter is designed to provide utmost flexibility, including bandswitching and provision for crystal control from its own crystal oscillator or excitation from a separate variable-frequency oscillator.

R.F. Section

The r.f. section, which is placed at the top of the 17½ inch rack-cabinet, employs a 6L6 as a crystal oscillator followed by another

6L6 as a doubler-quadrupler and an HY-69 amplifier-doubler output stage. All bands from 160 to 10 meters are covered through the use of both stage switching and coil switching.

Bandswitching. For 160-meter operation, a crystal in that band is placed in the crystal socket on the panel and switch S_1 (figure 4) is thrown to the upper position. With S_1 in this position the HY-69 is excited directly from the crystal oscillator plate circuit, the doubler-quadrupler stage being cut out of the circuit. Either 160- or 80-meter crystals may be used when 80-meter output is desired, with the HY-69 being operated either as a straight amplifier or doubler.

To reach 40 meters, S_1 is thrown to the lower position, cutting in the second 6L6. An 80-meter crystal is used for this band. The doubler-quadrupler plate circuit is tuned to 20 meters for 20- or 10-meter output and the HY-69 used as a straight amplifier on 20 meters or doubler to 10 meters.

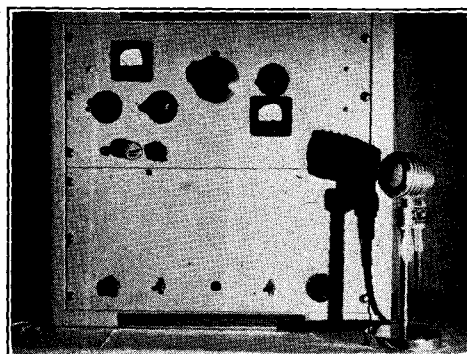

Figure 1.

40-WATT EXCITER-TRANSMITTER.

By itself, this unit forms a complete 40-watt phone-c.w. transmitter. With the r.f. amplifier and modulator unit shown later in this chapter it forms a 200-watt transmitter for phone or c.w. operation on bands from 10 to 160 meters.

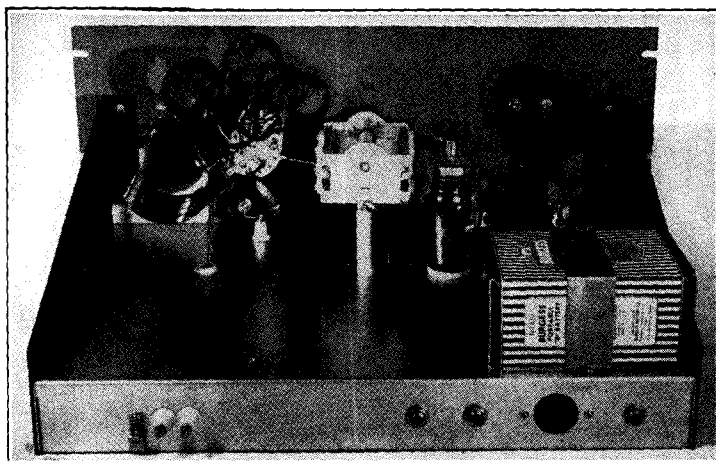

Figure 2.

R.F. SECTION CHASSIS.

The r.f. components of the exciter-transmitter are located on this chassis, which is located at the top of the cabinet shown in figure 1. The battery at the rear of the chassis supplies fixed bias to the exciter stage, to allow crystal keying.

The high capacity plate tank condensers in the two 6L6 stages allow plenty of leeway in winding coils for these stages which will hit two adjacent bands. Although the condensers are somewhat larger than they need to be to cover two bands, their cost is but little greater than that of condensers which will "just cover" the required frequency range. The small additional cost is easily offset by the reduction of coil-winding difficulties. Battery bias is used on the doubler-quadrupler and output stages to permit the use of crystal keying and to allow the doubler-quadrupler to be operated without excitation on the 80- and 160-meter bands. The battery is mounted on

the r.f. chassis, and since the current through the battery is small, it may be expected to give long life.

Coil Turret. A manufactured coil-turret assembly is used in the plate circuit of the HY-69 stage. The turret is composed of four coils, separate coils being used for the 10-, 20-, and 40-meter bands, while a single tapped coil is used to cover the 80- and 160-meter bands. One change is required in the coil assembly, as supplied by the manufacturer, to adapt it to use in this transmitter. This change simply involves removing one turn from the two-turn coupling loop on the 10-meter coil, since tests show that the maximum efficiency of transfer to the antenna or following stage is obtained when the coupling coil is reduced to one turn. When used as a low power transmitter, the r.f. unit should be coupled to the antenna by means of a universal coupler, as shown in *Chapter Twenty*.

Metering. The two meters visible on the panel read the plate and grid currents on the output stage. The grid meter serves to show when the doubler-quadrupler stage is tuned to resonance, no other meter being needed for this purpose. When the output stage is operated on the 20- and 10-meter bands, where the excitation is from the doubler-quadrupler, it is helpful to have some indication of the operation of the crystal oscillator stage, however, and the pilot light at the lower left corner of the panel makes a convenient, inexpensive indicator. The 150-ma., 6.3-volt pilot lamp is coupled to the crystal stage plate coil through a one-turn loop, L_4 .

V.F.O. Operation. Means for exciting the transmitter-exciter from a variable frequency oscillator is provided by a two-turn coil, L_2 ,

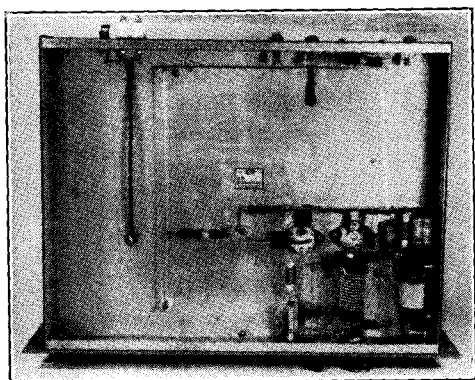
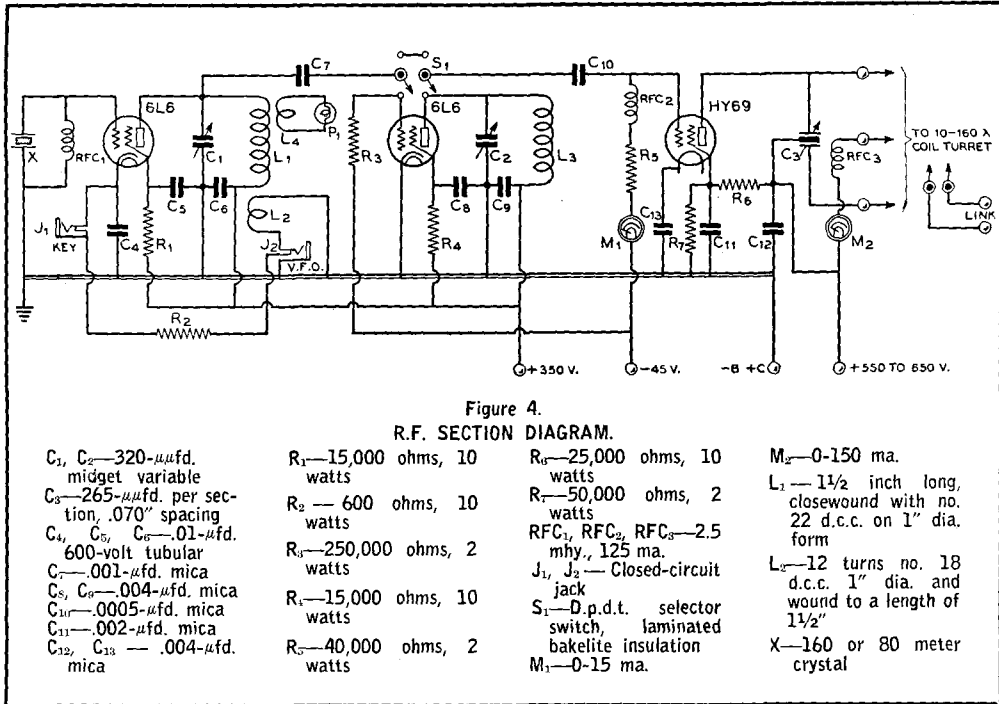

Figure 3.

UNDER THE R.F. CHASSIS

The location of the plate coils for the two 6L6 stages is clearly shown in this photograph. It is important that the twisted leads connecting to the r.f. output terminals at the rear of the chassis be kept well separated from the HY-69 grid circuit.



around the ground end of the crystal stage plate coil. When an ordinary phone plug is used to terminate the link from the v.f.o., placing the plug in J_2 couples the v.f.o. to L_1 and, at the same time, opens the cathode circuit of the crystal oscillator circuit by breaking the circuit between R_2 and ground. The crystal stage plate tank circuit acts as a tuned grid circuit for the second 6L6 or the HY-69 when a v.f.o. is used.

Power Supply and Audio Chassis

The lower chassis in the rack, which, like the r.f. chassis, measures 13 by 17 inches, mounts the audio and power supply section of the transmitter-exciter.

Audio Section. The audio section of the transmitter is intended to serve as a modulator for the HY-69, to form a complete phone transmitter, or as a driver for a class B modulator, when the r.f. section is used as an exciter for a medium power final amplifier. Although the normal output rating for 6A3's is only 10 watts, it is possible to obtain nearly three times this output by driving the grids somewhat and using a low value of plate load. This amount of output is sufficient to fully modulate a plate input of 60 watts to the HY-69. The modulation transformer secondary is merely connected in series with the plate

supply to the HY-69, to use the unit as a complete phone transmitter.

As the wiring diagram shows, the circuit of the speech amplifier is strictly conventional. The amplifier is designed to give full output with diaphragm type crystal microphones (-45 to -50 db output level). High level moving-coil (dynamic) microphones will also supply sufficient input to the speech amplifier, if this type is preferred. The 6SJ7 grid resistor, R_1 , should be replaced by a line-to-grid transformer if a moving-coil microphone is used. Since the speech amplifier and the power supply are on the same chassis, it will probably be necessary to revolve the input transformer while listening to the output of the amplifier to determine the mounting position which results in minimum hum pickup.

Power Supply. A single transformer rated at 460 volts a.c. each side of the center tap at 325 milliamperes is used in the dual-voltage power supply. To handle the 300 milliamperes of current drawn by the complete transmitter-exciter, two type 83 rectifiers are used. One of the rectifiers operates into a condenser-input filter and delivers 600 volts at 100 millamperes to the HY-69 stage. The other 83 rectifier delivers voltage to a two-section, choke-input filter and thence to the 6L6 r.f. stages and to the speech amplifier-

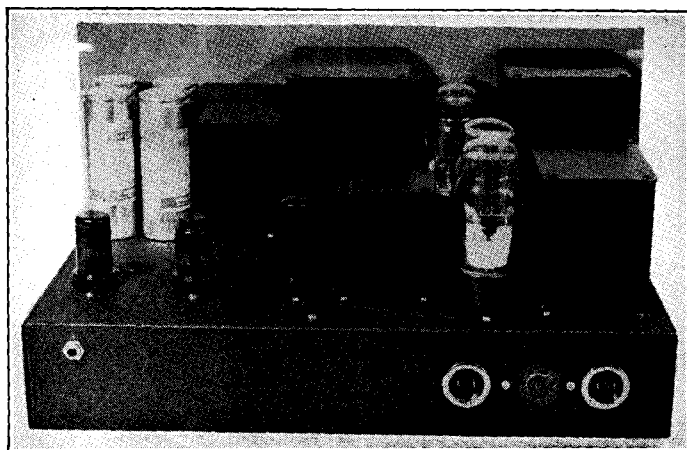

Figure 5.
AUDIO AND POWER SUPPLY SECTION.

All of the audio and power supply components are located on this, the lower chassis in the rack. Outlets at the rear of this chassis are provided for the microphone, line voltage, cable to r.f. section and external switch.

modulator. Plate voltage for the 6A3 audio output is taken from the junction of the two filter chokes following the latter rectifier.

Filament transformer T_2 supplies all of the filament requirements of the unit. This transformer has two 5-volt and two 6.3-volt

windings. Each of the 5-volt windings supplies one rectifier tube, while one of the 6.3-volt windings supplies heater power to the entire transmitter with the exception of the push-pull 6A3 stage, which must have a separate winding to allow the use of cathode bias.

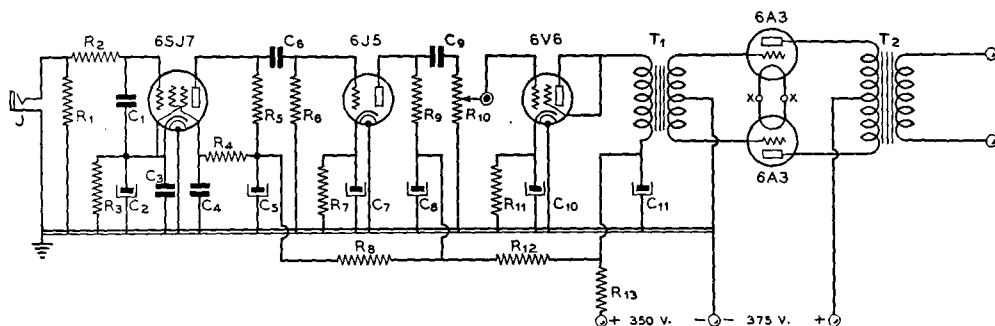

Figure 6.

SPEECH AND MODULATOR CIRCUIT.

C_1 —0.001- μ fd. mica
 C_2 —10- μ fd. 25-volt electrolytic
 C_3 —0.1- μ fd. 600-volt tubular
 C_4 —25- μ fd. 600-volt tubular
 C_5 —8- μ fd. 450-volt electrolytic
 C_6 —0.5- μ fd. 600-volt tubular
 C_7 —10- μ fd. 25-volt electrolytic
 C_8 —8- μ fd. 450-volt tubular

C_9 —0.5- μ fd. 600-volt tubular
 C_{10} —10- μ fd. 50-volt electrolytic
 C_{11} —8- μ fd. 450-volt electrolytic
 R_1 —1 megohm, 1/2 watt
 R_2 —25,000 ohms, 1/2 watt
 R_3 —500 ohms, 1/2 watt
 R_4 —1 megohm, 1/2 watt
 R_5 —100,000 ohms, 1/2 watt
 R_6 —500,000 ohms, 1/2 watt

R_7 —1000 ohms, 1 watt
 R_8 —25,000 ohms, 1 watt
 R_9 —50,000 ohms, 1 watt
 R_{10} —250,000 - ohm potentiometer
 R_{11} —600 ohms, 2 watts
 R_{12} —15,000 ohms, 20 watts
 R_{13} —2500 ohms, 10 watts
 T_1 —Driver transformer for triode-connected 6F6 to class B grids.

3:1 ratio, pri. to 1/2 sec.
 T_2 —40-watt variable-ratio modulation transformer. Connected to give 3000-ohm modulator plate-to-plate load with 6000-ohm r.f. load. (For driver service substitute driver transformer with 3:1 pri. to 1/2 sec. ratio.)
 J —Single-circuit jack

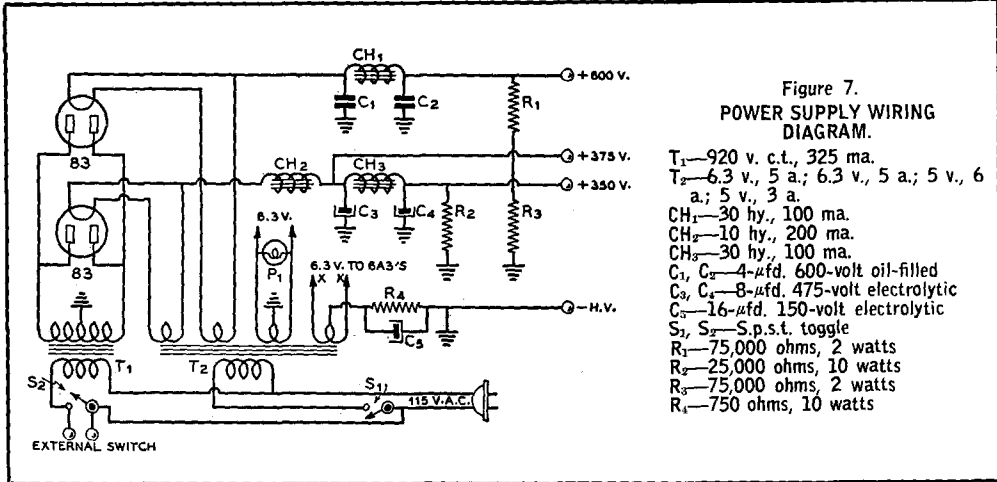

Figure 7.
POWER SUPPLY WIRING DIAGRAM.

- T₁—920 v. c.t., 325 ma.
- T₂—6.3 v., 5 a.; 6.3 v., 5 a.; 5 v., 6 a.; 5 v., 3 a.
- CH₁—30 hy., 100 ma.
- CH₂—10 hy., 200 ma.
- CH₃—30 hy., 100 ma.
- C₁, C₂—4- μ fd. 600-volt oil-filled
- C₃, C₄—8- μ fd. 475-volt electrolytic
- C₅—16- μ fd. 150-volt electrolytic
- S₁, S₂—S.p.s.t. toggle
- R₁—75,000 ohms, 2 watts
- R₂—25,000 ohms, 10 watts
- R₃—75,000 ohms, 2 watts
- R₄—750 ohms, 10 watts

Operation

To place the unit into operation it is necessary merely to place the proper crystal in the oscillator stage, throw S₁ to the correct position, depending upon the output frequency desired, switch to the proper plate coil in the HY-69 stage, and tune each stage to resonance as indicated by the meters and the pilot light r.f. indicator. The only trouble which is liable to be experienced is oscillation in the HY-69 stage on 20 meters, the highest frequency at which this stage runs as a straight amplifier. If oscillation occurs, it will probably be traceable to capacity coupling between the antenna coupling leads below the chassis and the HY-69 grid circuit, and these leads should be kept well separated. Should oscillation persist with the antenna leads well separated from the grid circuit wiring and with the transmitter loaded by the antenna it will be necessary to shield the antenna leads by placing a shield braid over them and grounding the braid to the chassis.

Normal grid current on the HY-69 is 5 milliamperes. The tank circuit may be loaded by the antenna or following stage until the plate current reaches 100 milliamperes.

watts. The r.f. output stage together with its associated modulator and power supply is housed in a 26 $\frac{1}{4}$ inch rack cabinet which matches that used for the exciter stages.

200-WATT R.F. AMPLIFIER AND MODULATOR

The unit shown in figure 8 and diagrammed in figure 9 has been designed specifically to operate in conjunction with the 40-watt r.f. and audio driver unit previously described. Together the two units form a complete phone-c.w. transmitter with an output of 200

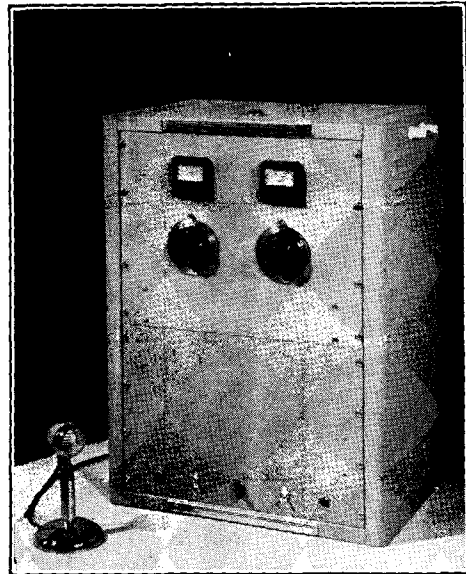

Figure 8.
200-WATT R.F. AMPLIFIER AND MODULATOR.

Inside this cabinet are two chassis, one consisting of a push-pull 812 r.f. amplifier and the other a 1250-volt power supply and a class B 811 modulator. The switches on the lower panel control the filament and plate voltages and disconnect the modulator for c.w. operation. Antenna connections are made to the two standoff insulators near the top of the right side of the cabinet.

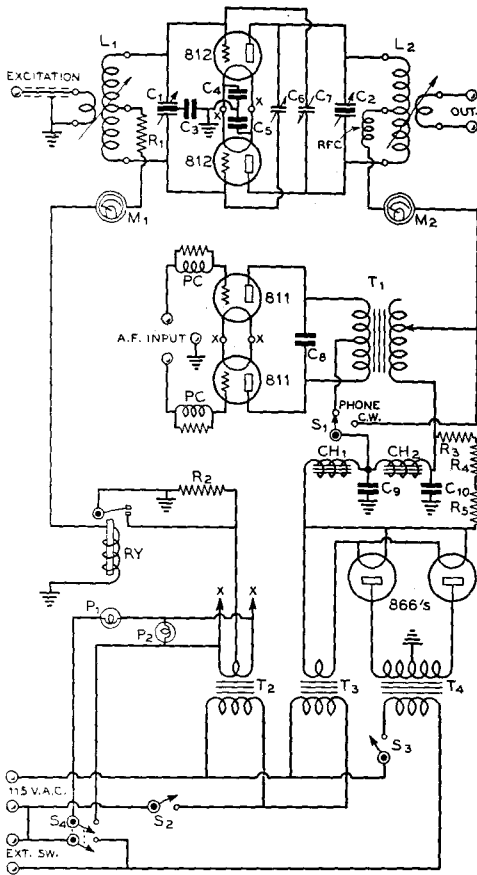

Figure 9.

THE WIRING DIAGRAM FOR THE 812 AMPLIFIER AND MODULATOR

- C₁—140- μ fd. per section midget variable
- C₂—200- μ fd. per section, .100" spacing
- C₃—0.02- μ fd. mica
- C₄, C₅—0.04- μ fd. mica
- C₆, C₇—6- μ fd. midget variable, .200" spacing
- C₈—0.02- μ fd. 5000-volt mica
- C₉, C₁₀—4- μ fd. 1500-volt oil-filled
- R₁—3000 ohms, 20 watts
- R₂—500 ohms, 20 watts
- R₃, R₄, R₅—100,000 ohms, 1 watt
- RFC—5 - mhy., 500 - ma. choke
- L₁—Manufactured variable-link "50-Watt" coils. See text for padder on 160-meter coil.
- L₂—"500-Watt" manufactured coils with variable-link mounting
- T₁—125-watt variable-impedance modulation transformer
- T₂—6.3 v., 20 a.
- T₃—2.5 v., 10 a., 10,000-volt insulation
- T₄—2850 v., c.t., 300 ma.
- M₁—0-100 ma.
- M₂—0-300 ma.
- RY—30-ma. relay
- S₁—Single-pole, four-position tap switch (only two positions used). Should have wide spacing between contacts.
- S₂—S.p.s.t. toggle
- S₃—S.p.s.t. door switch
- S₄—S.p.d.t. toggle
- S₅—S.p.d.t. toggle
- P₁, P₂—6.3-volt pilot lamp
- PC—Parasitic choke

The R.F. Amplifier

To provide the best balance between cost and a reasonable amount of power output, the tubes used in the r.f. amplifier are 812's. These tubes are moderate in cost, yet they are capable of producing a 200-watt carrier with a small amount of excitation and a medium-voltage power supply. The input necessary for 200 watts of output is approximately 250 watts (1300 volts at 200 ma.). The photograph of figure 10 shows clearly the mechanical layout of the stage. The chassis, which measures 17 by 13 by 3 inches, is surmounted by a 14-inch rack-notched panel. The grid coil plugs into a socket near the left edge of the chassis. Between the grid coil and the tubes is located the split stator grid condenser, which is held 1 3/8 inches above the chassis by spacers to allow its dial to line up with the plate condenser dial. The leads from the grid condenser stators are carried through the chassis to the socket grid terminals by small feedthrough insulators.

To aid in keeping the neutralizing leads short, the neutralizing condensers are placed side by side between the 812's. These condensers are supported from their rear mounting feet by small feedthrough insulators, which also serve to carry the rotor connection to the grid terminals at the sockets. Connecting the neutralizing condensers directly to the grid terminals, rather than to the grid condenser above the chassis, reduces the length of lead which is common to both the neutralizing and tank circuits, thus aiding in securing complete neutralization on all bands. When once set, the neutralizing adjustment need not be changed when changing bands.

Coils. Standard manufactured coil assemblies are used in both the grid and plate circuits of the 200-watt amplifier. The plate coil jack bar assembly has a swinging pickup loop permanently connected to it. This loop is a flat-wound coil designed specifically to permit a good energy transfer to the antenna regardless of the diameter of the plate coil. The grid coupling loops are an integral part of each grid coil, being mounted in the coil plug in such a way that the coupling may be varied by pushing them in or out of the coil. The coupling should be adjusted so that the grid current measures 50 milliamperes with the amplifier loaded.

The manufactured coils available for use in the amplifier grid circuit require more capacity on the 160-meter band than is provided by the 140- μ fd. per section grid condenser, making it necessary to connect a padder condenser permanently across these

Figure 10.

P.P. 812 R.F. AMPLIFIER.

As with all push-pull amplifiers, symmetry is an important factor in the design of this stage. The plate and tank circuit leads are kept short by sinking the tube sockets below the chassis and mounting the plate coil assembly on tall standoff insulators.

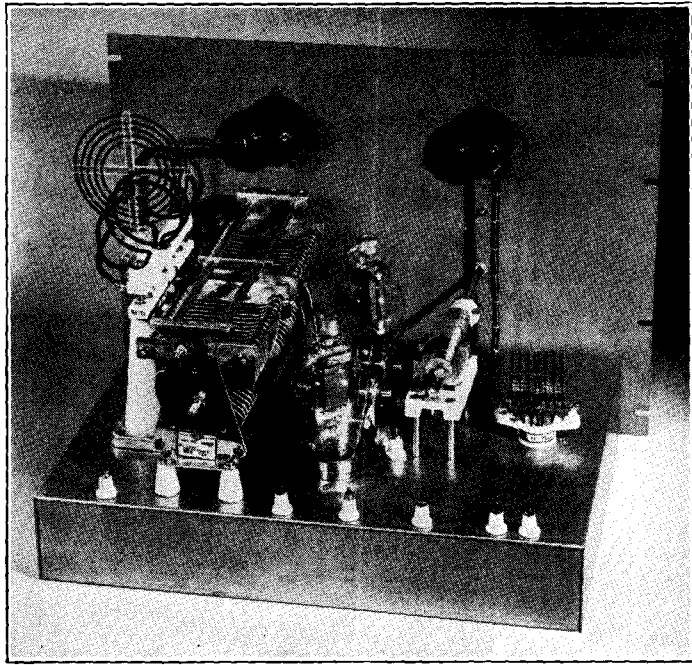

coils. The padder consists of a small, ceramic zero-temperature-coefficient $25\text{-}\mu\mu\text{fd}$. unit which is permanently connected across the 160-meter coil. It is essential that this condenser be of the type indicated, since the ordinary "postage stamp" type of mica condenser will not stand the circulating tank r.f. current without overheating.

Protective Bias. Relay RY is placed in the grid return circuit to allow protective cathode bias to be applied to the 812's when the excitation is removed. This arrangement allows the exciter to be keyed in the crystal oscillator stage without danger of damaging the final amplifier tubes. It also obviates the necessity for lowering the final amplifier plate voltage when the transmitter is being tuned, since there will always be sufficient bias on the 812's regardless of whether they are receiving grid excitation or not.

The relay is designed to close at a current of 30 milliamperes. When the grid current is less than this amount the relay contacts are opened and resistor R_2 is cut into the filament center tap circuit, placing sufficient cathode bias on the 812's so that the plate current is held to a safe value.

Modulator and Power Supply

The class B 811 modulator and the 1300-watt power supply for the modulator and r.f.

amplifier are mounted on the lower chassis in the rack. Top and bottom views of this section of the transmitter are shown in figures 12 and 13.

The Modulator. The modulator section of the transmitter needs little comment, since it consists merely of the two 811's and their associated output transformer. The two modu-

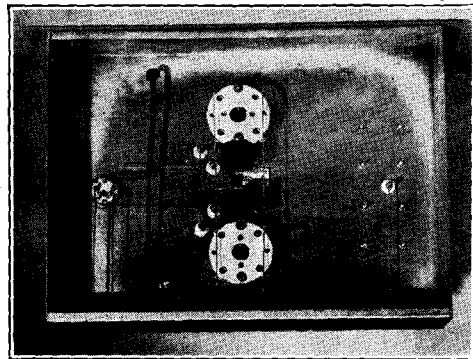

Figure 11.

BOTTOM VIEW OF THE R.F. AMPLIFIER.

The filament leads and most of the grid circuit r.f. wiring are under the chassis. Note that separate feedthrough insulators are used to carry the leads from the socket grid terminals to the grid and neutralizing condensers, thus eliminating common grid and neutralizing circuit leads.

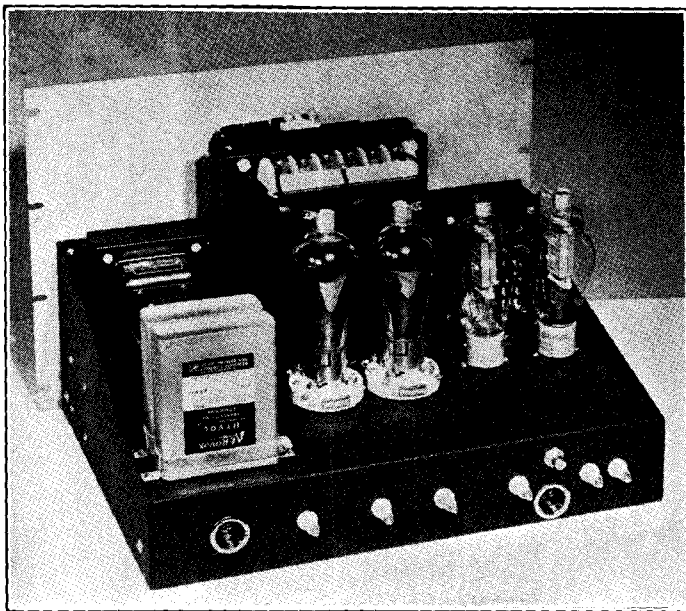
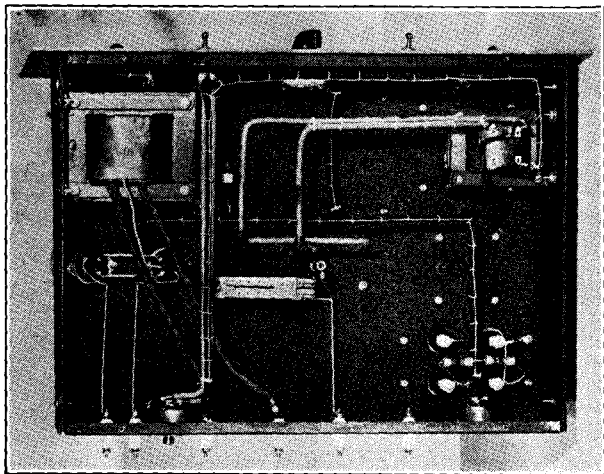

Figure 12.
POWER SUPPLY AND 811
MODULATOR.

The major portion of this chassis is given over to the power supply components. The power transformer is located near the panel to reduce its "leverage" on the panel mounting screws. The modulators are located near the right edge of the chassis with the modulation transformer between the tubes and the panel. Note the safety door switch on the rear drop of the chassis above the right-hand 110-volt connector.

Figure 13.
UNDER THE POWER SUPPLY-
MODULATOR CHASSIS.
The 2.5-volt and 6.3-volt filament transformers are located under this chassis. Near the center of the chassis the grid-current-operated safety bias relay may be seen.



lator tubes are located near the left edge of the chassis with the output transformer between them and the panel. The wiring diagram shows parasitic suppressors in the modulator grid leads. These, however, may not be necessary—they are included in the diagram to show where they should be placed in case modulator parasitics should develop. C_8 between the modulator plates reduces high frequency harmonics from the modulator, which cause the signal to "splatter," and this condenser should not be omitted in any case.

The modulator driver transformer is located on the exciter chassis, the correct unit being indicated in the caption under figure 6. A tapped 125-watt modulation transformer couples the modulators to the r.f. load. The taps on the transformer are adjusted to reflect a 15,000-ohm load on the modulators when working into 6500-ohm secondary load. Switch S_1 , which shorts out the modulation transformer secondary and removes the plate voltage from the modulator for c.w. work, is a ceramic single-pole four-position tap switch.

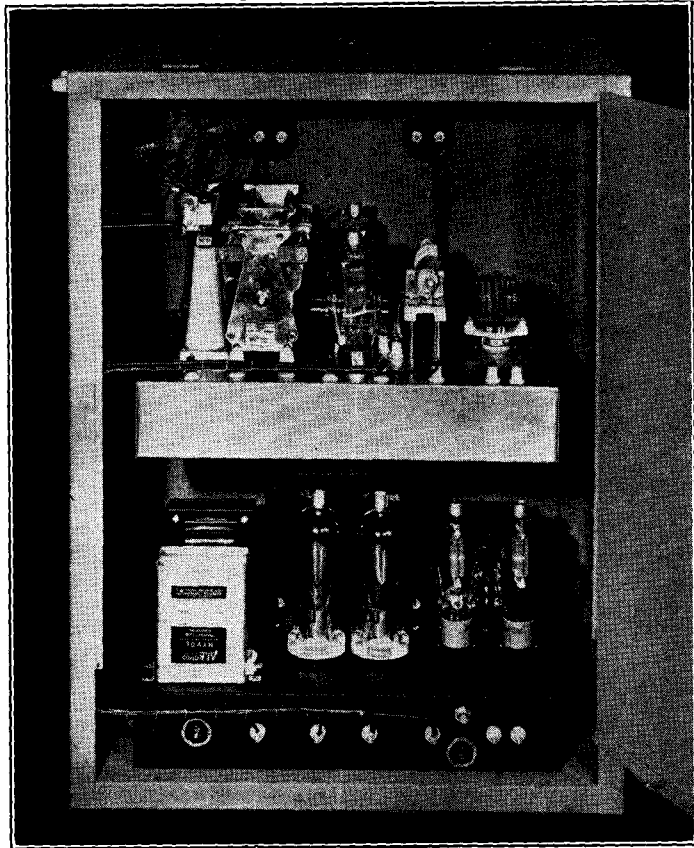

Figure 14.

REAR VIEW OF R.F. AMPLIFIER AND MODULATOR.

Neatly cabled leads between the two chassis aid in giving the unit a finished appearance. The two standoff insulators near the right edge of the upper chassis are for link connections from the r.f. exciter, while the similar insulators on the lower chassis connect to the audio driver.

Only two of the taps on the switch are actually in use—it was chosen because of the wide spacing between contacts.

Power Supply. The power supply section of the final amplifier and modulator unit occupies the center and right-hand portion of the lower chassis. The locations of the various components are plainly visible in figures 12 and 13.

Of the three switches shown in the power supply wiring diagram, two are on the panel. These are S_2 and S_4 . S_2 is placed in series with the primaries of the two filament transformers and controls all of the amplifier filaments. S_4 controls the plate voltage to the final amplifier and modulator. S_3 is a safety "door switch" in series with the primary of the plate transformer. This switch is located on the rear drop of the chassis and closes only when the rear door of the rack is closed. It is operated by the long machine screw visible on the inside of the rear door in figure 14.

The leads marked "external switch" are connected in parallel with the similarly marked leads in the exciter power supply. Closing the plate switch in either the exciter amplifier section of the transmitter or closing a separate, external switch across the leads will turn on the plate power in both sections. Care should be taken to make sure that the side of the external switch line which is connected to the 115-volt supply at the r.f. amplifier-modulator end is connected to the corresponding external switch lead at the exciter end. Since one side of the a.c. supply voltage is connected to the common external switch lead at each unit care must also be taken in connecting the line voltage to the two units to ascertain that the 115-volt a.c. line will not be shorted. A close inspection of the two diagrams will show the need for observing this precaution.

Three 100,000-ohm, 1-watt resistors, R_3 , R_4 and R_5 , are used to bleed off the charge in the

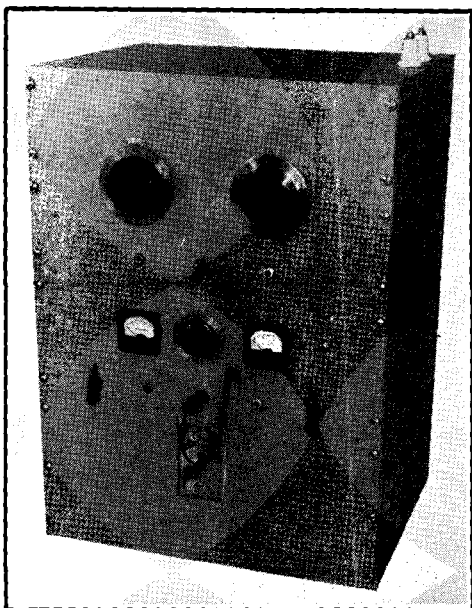

Figure 15.

**100-WATT 35-T CATHODE MODULATED
PHONE FOR 10-160 METERS.**

Featuring high overall efficiency with low cost, this transmitter has many of the advantages of both plate modulation and grid modulation.

filter condensers should the power supply be turned off when there is no load being drawn from it. These resistors are included as a safety precaution; they do not serve as a "bleeder" to improve the power supply regulation, since in normal operation no bleeder will be needed because there will always be sufficient load on the power supply, even when the transmitter is being keyed for c.w. operation.

**100-WATT 10-160 METER 35-T
CATHODE MODULATED PHONE**

While it is necessary to use at least 2000 volts on tubes such as the 35-T in order to get good efficiency with ordinary grid modulation, it is possible to get the same efficiency at 1500 volts when cathode modulation is used, and the adjustments are not quite so critical. With cathode modulation the modulation of the grid bias is augmented by a small amount of plate modulation, the cathode being common to both grid and plate circuits. Somewhat more audio power is required for cathode modulation, but it is still low enough that a

simple, inexpensive modulator can be used for carrier powers of 100 to 150 watts. The required r.f. grid drive is also slightly greater.

The 35-T cathode modulated transmitter illustrated will deliver slightly over 100 watts of carrier with 200 watts input. This means that the 35-T's must each dissipate about 45 watts, but they will do this safely in grid or cathode modulated service *provided they have good ventilation.*

Circuit. A 6L6-G harmonic oscillator delivers output on either 1, 2, or 4 times crystal frequency. A neutralized 35-T delivers output on either 1 or 2 times excitation frequency. This means that the transmitter may be operated at 1, 2, 4, or 8 times crystal frequency.

The 35-T buffer-doubler is supplied with a high value of grid leak bias in order to limit the plate current and permit high efficiency when doubling. Because of the reserve of excitation supplied by the 35-T, it is possible to use capacity coupling to the final stage even though the transmitter is designed to include 10-meter operation. This minimizes the total number of coils required.

To provide low C on 10 meters yet allow sufficient Q for good 75- and 160-meter operation, a 50- μ fd. per section condenser is used for the final plate tank and fixed air padding condensers plugged in on 75 and 160 meters to provide the necessary capacity for proper operation on these two bands.

Audio Section. Automatic gain control is provided to minimize overmodulation and permit a higher average percentage of modulation. The initial adjustment of R_{31} should be made with the assistance of a c.r. oscilloscope. The operation of a.g.c. circuits is discussed in *Chapter Fourteen.*

The particular phase inverter used is very stable and not critical with respect to tubes. It need not be initially adjusted by means of a meter or c.r. oscilloscope if the resistors used have a reasonable degree of accuracy.

The self-biased 6L6's deliver sufficient output for full modulation of the 35-T's when the latter are run at a plate efficiency of between 50 and 55 per cent. A transformer designed for coupling four 6L6's in push-pull-parallel to a 500-ohm line is used to couple the modulator to the final amplifier. Since the load impedance presented by the modulated amplifier cathode circuit is somewhat higher than the 500 ohms the transformer is intended to work into, the primary impedance is correspondingly raised to a value approximately correct for the pair of self-biased 6L6's. The secondary winding must carry about 150 ma., which it seems to do without bad effects

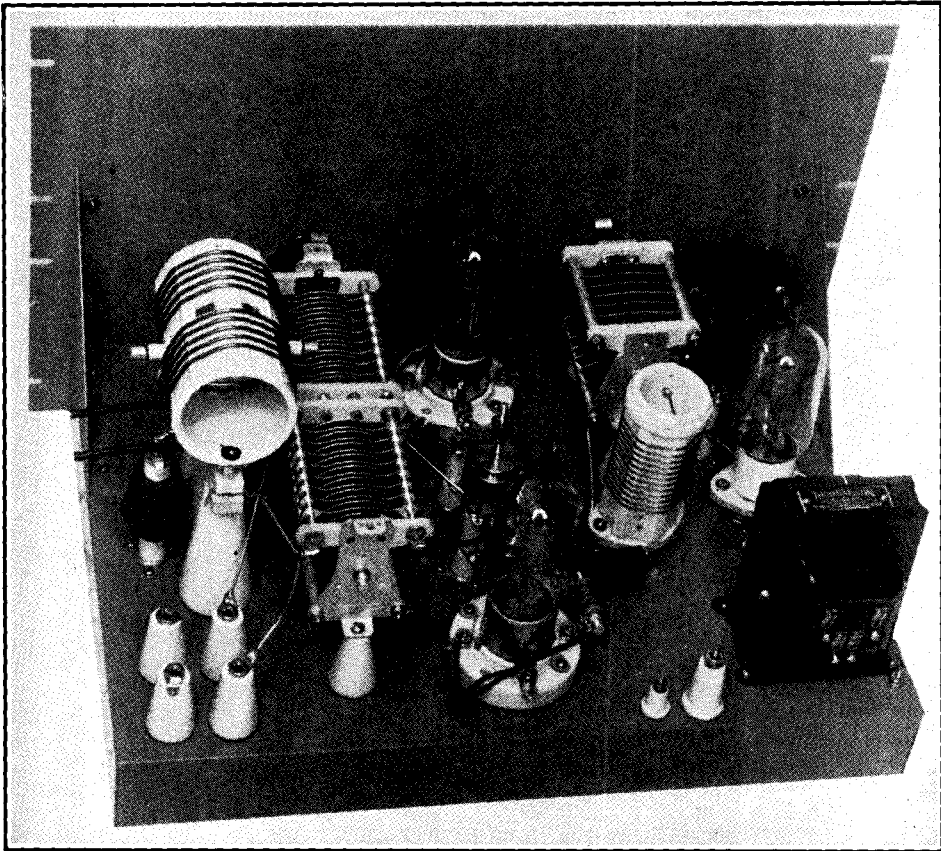

Figure 16.

BUFFER AND FINAL AMPLIFIER STAGES.

To minimize the required number of coils, the 35-T buffer-doubler is capacitively coupled to the final amplifier. The buffer filament transformer and the cathode modulation transformer are mounted on the chassis with the r.f. components. Note the jacks for the plug-in fixed air condenser for 80 and 160 meter operation.

in spite of the fact that it was not designed to carry d.c. Evidently the wire is heavy enough and the impedance of the winding low enough that there is neither heating of the wire nor core saturation. A special transformer designed specifically for cathode modulation could be used to good advantage in place of the transformer used in the original transmitter.

Operation. The excitation and loading adjustments are not critical. Simply increase the bias on the 35-T's by means of the selector switch connected to R_7 until 10 to 20 ma. of grid current flows and the stage modulates up properly. If the plate current and tube dissipation are excessive, reduce the antenna coupling and repeat the bias adjustment. If the dissipation and plate current are low, in-

crease the antenna coupling and repeat the bias adjustment. Under correct operating conditions both grid current and plate current to the 35-T's will be substantially constant during modulation.

Typical meter readings for correct operation are as follows:

Osc. cathode—35 to 60 ma.

35-T buffer cathode—45 to 65 ma.

35-T doubler cathode—65 to 80 ma.

Final grid current—10 to 20 ma.

Final plate current—140 to 150 ma.

These readings hold for a 35-T plate voltage of 1500 volts and modulator and exciter voltage of 400 volts.

HK-54's may be substituted for the 35-T's if desired. No changes in circuit constants will be necessary.

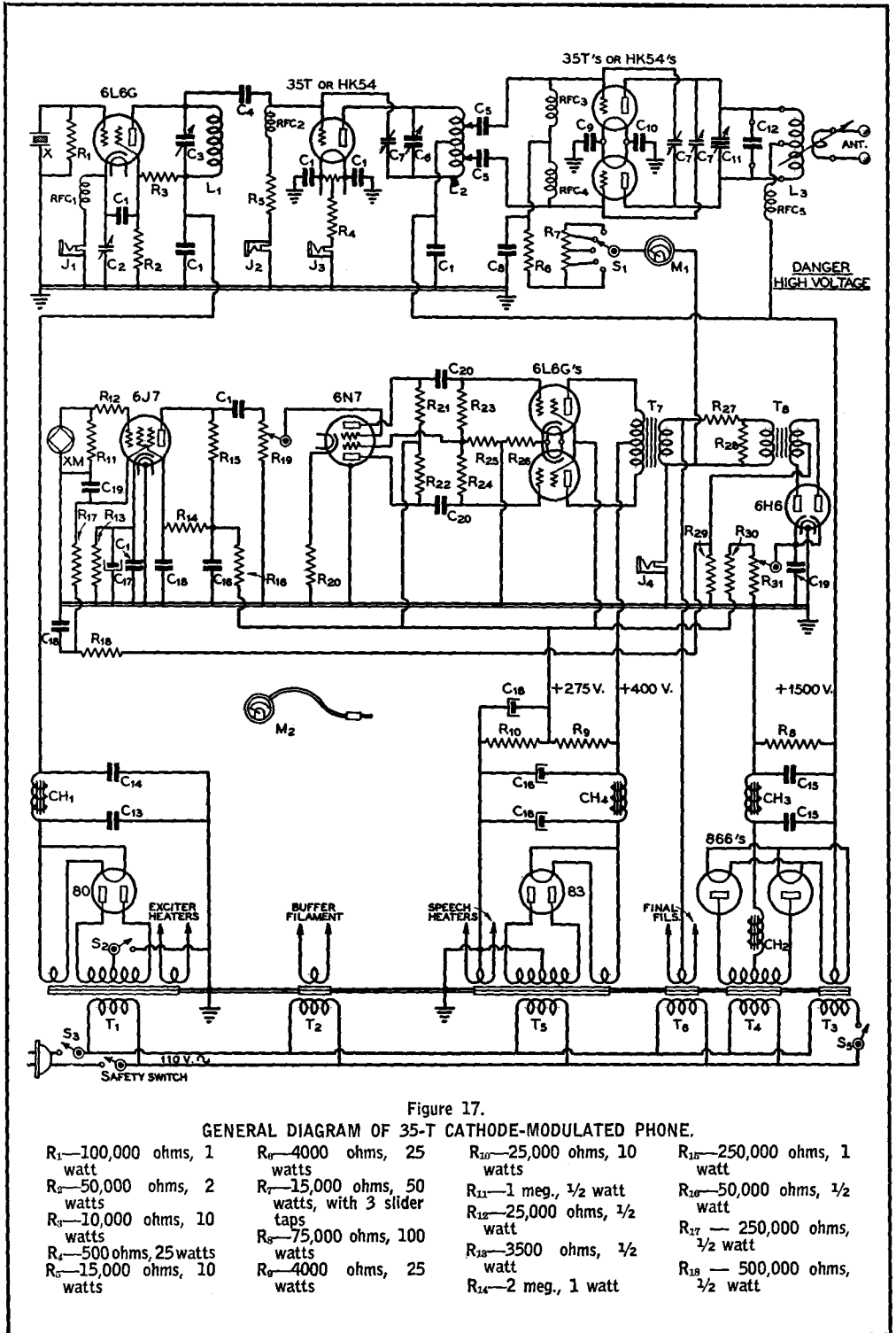

Figure 17.

GENERAL DIAGRAM OF 35-T CATHODE-MODULATED PHONE.

- | | | | |
|---------------------------------------|---|--|---------------------------------------|
| R ₁ —100,000 ohms, 1 watt | R ₆ —4000 ohms, 25 watts | R ₁₀ —25,000 ohms, 10 watts | R ₁₈ —250,000 ohms, 1 watt |
| R ₂ —50,000 ohms, 2 watts | R ₇ —15,000 ohms, 50 watts, with 3 slider taps | R ₁₁ —1 meg., ½ watt | R ₁₉ —50,000 ohms, ½ watt |
| R ₃ —10,000 ohms, 10 watts | R ₈ —75,000 ohms, 100 watts | R ₁₂ —25,000 ohms, ½ watt | R ₁₇ —250,000 ohms, ½ watt |
| R ₄ —500 ohms, 25 watts | R ₉ —4000 ohms, 25 watts | R ₁₃ —3500 ohms, ½ watt | R ₁₈ —500,000 ohms, ½ watt |
| R ₅ —15,000 ohms, 10 watts | | R ₁₄ —2 meg., 1 watt | |

R ₁₉ —1 meg. pot. gain control	M ₁ —0-50 ma. d.c.	C ₉ , C ₁₀ — .002- μ fd. mica, 600 v.	T ₁ —680 volts c.t., 65 ma., and indicated fil.
R ₂₀ —1000 ohms, 1/2 watt	M ₂ —0-300 ma. d.c.	C ₁₁ —50- μ fd. per section, 3000 v. spacing	T ₂ —5 v. 4 amp.
R ₂₁ —100,000 ohms, 1 watt	RFC ₁ , RFC ₂ , RFC ₃ , RFC ₄ —2.5 mh., 125 ma.	C ₁₂ —Fixed air padder, 0.144" air gap, 50 μ fd. for 75 m., 100 μ fd. for 160 m.	T ₃ —2.5 v. 10 amp., 5000 v. insulation
R ₂₂ —100,000 ohms, 1 watt	RFC ₅ —2.5 mh., 500 ma.	C ₁₃ , C ₁₄ —4- μ fd., 600 v. oil filled	T ₄ —3650 volts c.t., 300 ma.
R ₂₃ , R ₂₄ —250,000 ohms, 1/2 watt	C ₁ —01- μ fd. 600 v. tubular	C ₁₅ —2- μ fd. 1500 v. oil filled	T ₅ —700 volts c.t., 145 ma., and indicated fil.
R ₂₅ —100,000 ohms, 1/2 watt	C ₂ —200-600- μ fd. adjustable mica trimmer (padder)	C ₁₆ —8- μ fd. electrolytic, 450 v.	T ₆ —5.25 v., 10 amps.
R ₂₆ —200 ohms, 10 watts	C ₃ —50- μ fd. midget	C ₁₇ —10- μ fd. 25 v. electrolytic	T ₇ —3300 to 250 or 500 ohms, 40 to 60 watts, P.P. parallel 6L6 output to 250 or 500 ohm line
R ₂₇ —10,000 ohms, 1 watt	C ₄ —50- μ fd. mica, 1200 v.	C ₁₈ —0.1- μ fd. 600 v. paper tubular	CH ₁ —15 hy., 85 ma.
R ₂₈ —20,000 ohms, 1 watt	C ₅ —50- μ fd. mica, 5000 v.	C ₁₉ —0.5- μ fd. 400 v. paper	CH ₂ , CH ₃ —10 to 15 hy., 250 ma.
R ₂₉ —200,000 ohms, 1/2 watt	C ₆ —55- μ fd., 4500 v. spacing	C ₂₀ —0.02- μ fd. 600 v. tubular	CH ₄ —10 to 15 hy., 150 ma.
R ₃₀ —50,000 ohms, 1 watt	C ₇ —2- μ fd. micrometer neutralizing condensers		
R ₃₁ —100,000 ohm pot. auto-gain control	C ₈ —0.5- μ fd., 600 v. paper		

COIL DATA FOR 35-T CATHODE-MODULATED TRANSMITTER.

Band	Oscillator (Bakelite Coil Forms)	Buffer Plate (Ceramic Coil Forms)	Final Plate (Ceramic or Air Wound)
160	76 turns no. 22 enam. close wound, 1 1/2 in. dia.	82 turns no. 24 d.c.c. close wound c.t., tapped also 15 turns each side c.t., 1 3/4 in. dia.	40 turns no. 16 enam., c.t., 2 1/2 in. dia., spaced to 3 in., shunted with 100 μ fd. fixed air padder
80	36 turns no. 20 d.c.c. 1 1/2 in. dia., spaced to 2 in.	38 turns no. 18 enam., c.t., 1 3/4 in. dia., spaced to 2 in., also tapped 7 turns each side c.t.	24 turns no. 14 enam., c.t., 2 1/2 in. dia., spaced to 3 in., shunted with 50 μ fd. fixed air padder
40	18 turns no. 20 d.c.c. 1 1/2 in. dia., spaced to 1 1/2 in.	18 turns no. 18 enam., c.t., 1 3/4 in. dia., spaced to 1 1/2 in., also tapped 4 turns each side c.t.	18 turns no. 14 enam., c.t., 2 1/2 in. dia., spaced to 3 in.
20	9 turns no. 18 enam. 1 1/2 in. dia., spaced to 1 in.	12 turns no. 18 enam., c.t., 1 3/4 in. dia., spaced to 2 in., also tapped 3 turns each side c.t.	12 turns no. 12 enam., c.t., 2 1/2 in. dia., spaced to 3 in.
10	Use 20-meter coil	6 turns no. 16 enam., c.t., 1 3/4 in. dia., spaced to 2 1/2 in., also tapped 2 turns each side c.t.	6 turns no. 10 enam., c.t., 2 1/2 in. dia., spaced to 3 in.

250-WATT C. W. TRANSMITTER

With the addition of a 2000-volt, 200-milliampere power supply, the unit illustrated in figures 20, 22 and 23 makes a compact c.w. transmitter with an output of 250 watts. A suitable cathode modulator will be described later which allows the unit to be used as a 125-watt phone transmitter.

Circuit. Essentially the transmitter consists of a 6L6 crystal oscillator stage operating in the 80-meter band followed by three 6L6 doubler stages, and an 813 beam tetrode output stage. If desired, the transmitter may be used with a variable frequency exciter by connecting the v.f.o. output leads across the crystal socket. The v.f.o. output should be

at 160 meters, the crystal stage acting as a doubler to 80 meters.

Bandswitching. Excitation to the 813 stage on any band from 80 to 10 meters is obtained by use of nonresonant pickup coils wound around the plate coils of each of the doubler stages. Referring to the circuit diagram (figure 21) it may be seen that the upper section of S₁ connects the grid condenser of the 813 to the desired doubler. The lower section of S₁ serves to place full screen voltage on the stage being used to excite the final amplifier. Since each of the doubler stages supplies much more output than needed to drive a following 6L6 doubler, there is no need to run these stages at full screen voltage except when they are used to excite the final stage.

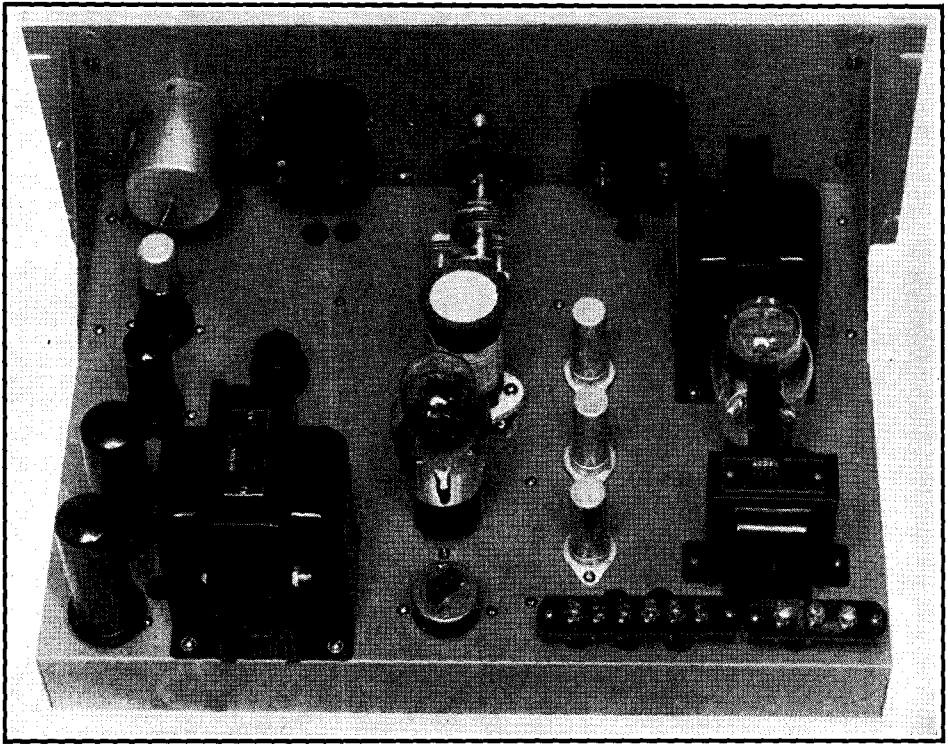

Figure 18.

SPEECH, OSCILLATOR, AND OSCILLATOR POWER SUPPLY.

Located on the second deck are the speech channel, a.g.c. components, crystal oscillator, and small power pack for the crystal oscillator. A relay in the center tap lead of the high voltage transformer turns the oscillator plate voltage on and off in unison with the plate voltage to the 35-T's, which have a plate transformer with no filament windings and can therefore be switched in the primary.

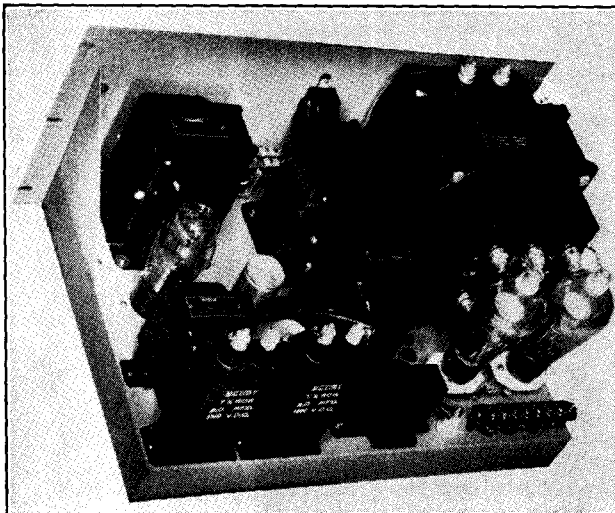

Figure 19.

1500-VOLT AND 400-VOLT POWER SUPPLIES.

The 1500-volt power supply for the buffer and final amplifier and the 400-volt supply for the speech system are mounted on the lower deck. Note that the heaviest components are mounted towards the front of the chassis. A 110-volt a.c. relay permits turning the transmitter on and off with one switch, in the 110-volt line.

Figure 20.
FRONT VIEW

From the front the 250-watt transmitter presents a neat and finished appearance. In a row along the bottom of the chassis are the tuning controls for the exciter stages and the exciter bandswitch and the meter switch controls. The large dial at the top center of the chassis resonates the final amplifier plate circuit.

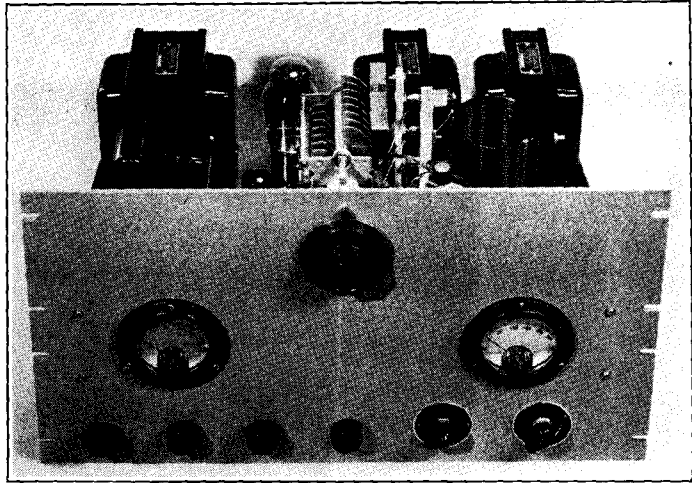

The last 6L6 (10-meter doubler) is used only to excite the 813 on ten meters, and for this reason the screen voltage to this stage is removed entirely except when the excitation switch is thrown to the ten-meter position.

It will be noted from the circuit diagram that in the first three exciter stages of the transmitter the tank condenser rotors are grounded and the r.f. circuit between the coils and tank condenser completed through mica condensers. On the 10-meter exciter stage, however, the condenser rotor is insulated from ground and condenser and coil by-passed to ground together. This circuit change in the 10-meter stage is made necessary because of the inadvisability of attempting to include a small mica condenser in the tank circuit at such a high frequency.

In the interest of maximum efficiency and compactness, plug-in coils are used in the 813 plate circuit. The four coils are shown in figure 24. Standard end-linked coils are used on the 80- and 40-meter bands, but since the manufactured coils available for use on the 20- and 10-meter bands had too much inductance for use with the high-output-capacity 813, these coils were inexpensively wound to the proper inductance and mounted on the same type jack bar as supplied with the manufactured coils. Data on the winding of the coils for the two high frequency bands are given under the photograph.

On all bands except 80 meters the tank capacity across the coils is provided by condenser C_5 alone. On 80 meters, however, an extra plug and a jumper on the coil plug bar place the additional 70- $\mu\mu\text{f}$. condenser C_6 across the coil. The addition of the other 70-

$\mu\mu\text{f}$. condenser is necessary to allow a good plate circuit Q to be realized at the lower frequency. Although C_6 is actually a variable condenser, as shown in the diagram, it is permanently set at full capacity and used as a fixed air condenser. The compactness and exact similarity of dimensions of C_6 with C_5 makes it better suited to use in regard to mounting and space requirements than would be a conventional fixed air condenser.

Bias and Power Supply. The exciter power supply utilizes a power transformer which is rated at 515 volts a.c. each side of center tap at 250 milliamperes. This transformer is also provided with a bias tap which delivers 30 volts a.c. for bias purposes. When rectified by a 5Z3 and filtered by a two-section, choke-input filter, the power supply output voltage is 400 volts under load. This voltage is used as plate and screen supply to the exciter stages and also as screen supply for the 813 output stage.

Through the use of a 6X5 as a half-wave bias rectifier, 40 volts of fixed protective bias is made available for all of the transmitter stages. The bias voltage is developed across the load resistor, R_{17} , and is filtered by a single 25- $\mu\mu\text{f}$. electrolytic condenser, C_{23} . Because the current drawn from the bias supply is small, and since the class C operated stages in the transmitter are incapable of operating as grid modulated amplifiers, any small amount of ripple voltage remaining in the bias supply after the small filter is not reproduced in the form of hum modulation on the carrier.

Terminals are provided at the rear of the transmitter chassis to allow the transmitter to be controlled from any convenient position.

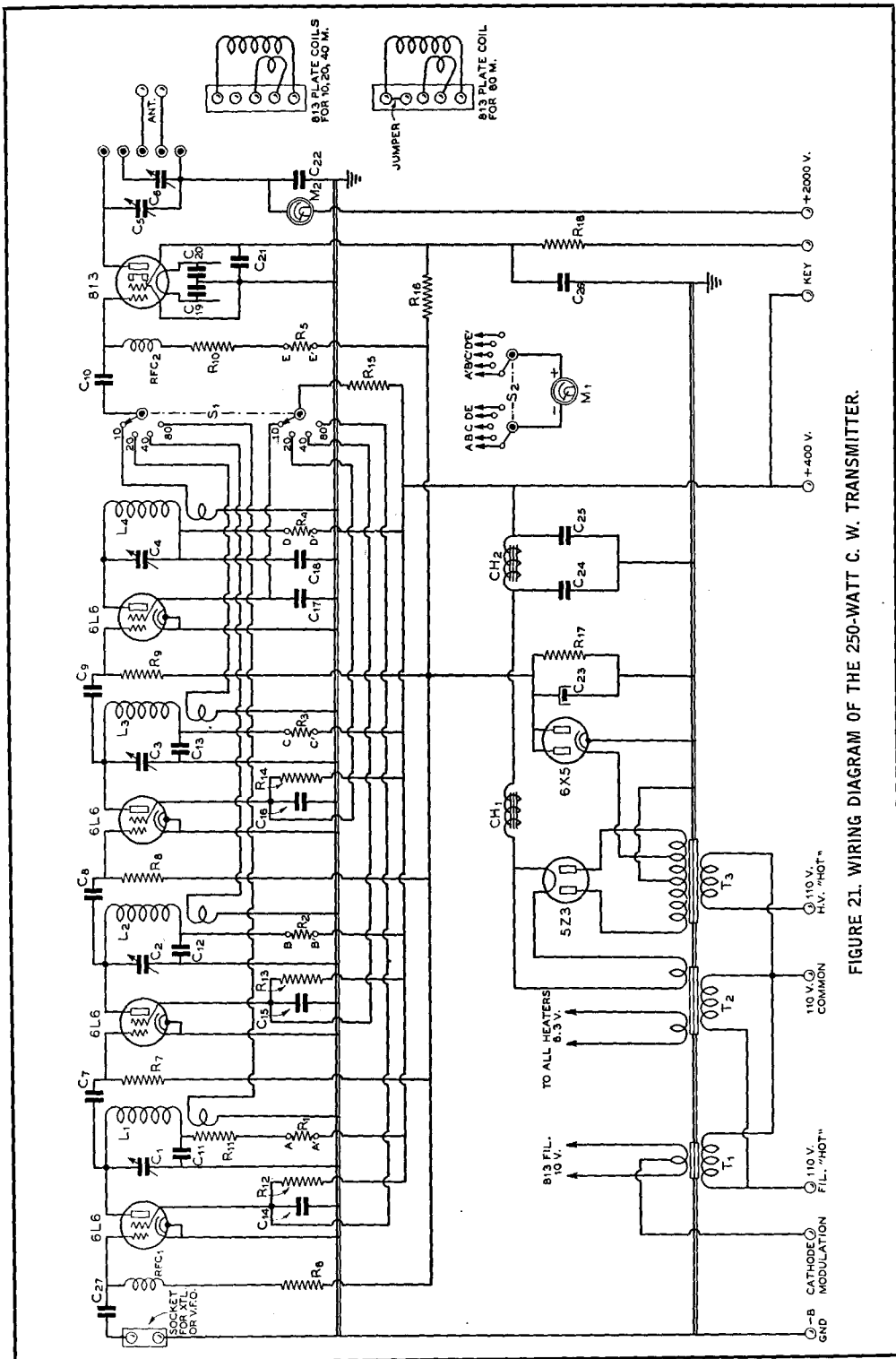

FIGURE 21. WIRING DIAGRAM OF THE 250-WATT C. W. TRANSMITTER.

VALUES OF COMPONENTS USED IN THE 250-WATT C. W. TRANSMITTER.

- | | | | |
|---|---|---|---|
| C ₁ , C ₂ —50- μ fd. midget variable | C ₂₄ , C ₂₅ —4- μ fd. 600-volt oil-filled | R ₁₆ —150,000 ohms, 2 watts | S ₂ —2-pole, 5-position selector switch |
| C ₃ —35- μ fd. midget variable | C ₂₆ —0.5- μ fd. 400-volt tubular | R ₁₇ —2000 ohms, 10 watts | M ₁ —0-100 ma. |
| C ₄ —15- μ fd. midget variable | C ₂₇ —0.001- μ fd. mica | R ₁₈ —5000 ohms, 10 watts | M ₂ —0-250 ma. |
| C ₅ , C ₆ —70- μ fd., .070" spacing | R ₁ , R ₂ , R ₃ , R ₄ , R ₅ —50 ohms, 1/2 watt | T ₁ —10 v., 8 a. | L ₁ —30 turns no. 20 d.c.c. closewound on 1 1/2" dia. form |
| C ₇ , C ₈ , C ₉ —0.0005- μ fd. mica | R ₆ —25,000 ohms, 1 watt | T ₂ —5 v., 3 a.; 6.3 v., 6 a. | L ₂ —25 turns no. 18 d.c.c. closewound on 1" dia. form |
| C ₁₀ —0.005- μ fd. mica | R ₇ , R ₈ , R ₉ —100,000 ohms, 2 watts | T ₃ —1030 v. c.t. bias tap at 30 v. | L ₃ —11 turns no. 20 d.c.c. spaced to occupy 1 1/2" on a 1" form |
| C ₁₁ , C ₁₂ , C ₁₃ —0.05- μ fd. 1000-volt mica | R ₁₀ —5000 ohms, 2 watts | CH ₁ , CH ₂ —13 hy., 250 ma. | L ₄ —8 turns no. 12 enam. 1" dia. and spaced to a length of 1 1/2". Self-supporting. |
| C ₁₄ to C ₂₁ —0.03- μ fd. mica | R ₁₁ —2000 ohms, 2 watts | RFC ₁ , RFC ₂ —2 1/2 mhy., 125 ma. | |
| C ₂₂ —0.01- μ fd. 5000-volt mica | R ₁₂ , R ₁₃ , R ₁₄ —100,000 ohms, 2 watts | S ₁ —2-pole, 4-position isolantite selector switch | |
| C ₂₃ —25- μ fd. 50-volt electrolytic | R ₁₅ —15,000 ohms, 10 watts | | |

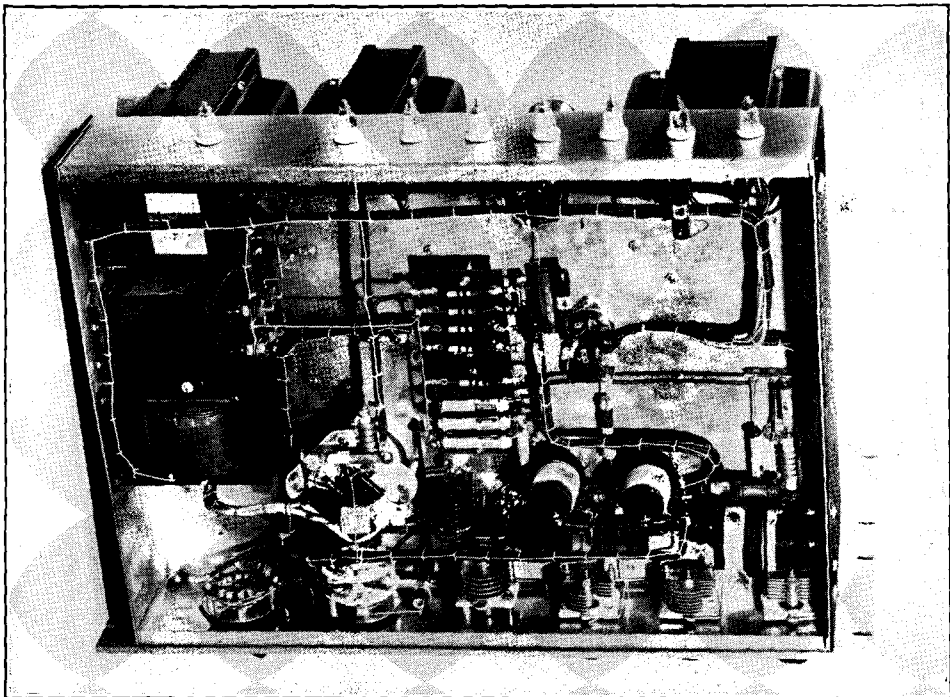

Figure 22.

UNDER-CHASSIS VIEW OF THE 813 TRANSMITTER.

Most of the wiring is under the chassis. Note that the 813 socket is sunk below the chassis and held in position with the aid of long 6-32 screws and 1-inch hollow spacers. To aid in wiring, the meter resistors and the doubler bias resistors are mounted on a strip at the center of the chassis. Cabling the d.c. leads together aids in giving a neat appearance to the transmitter.

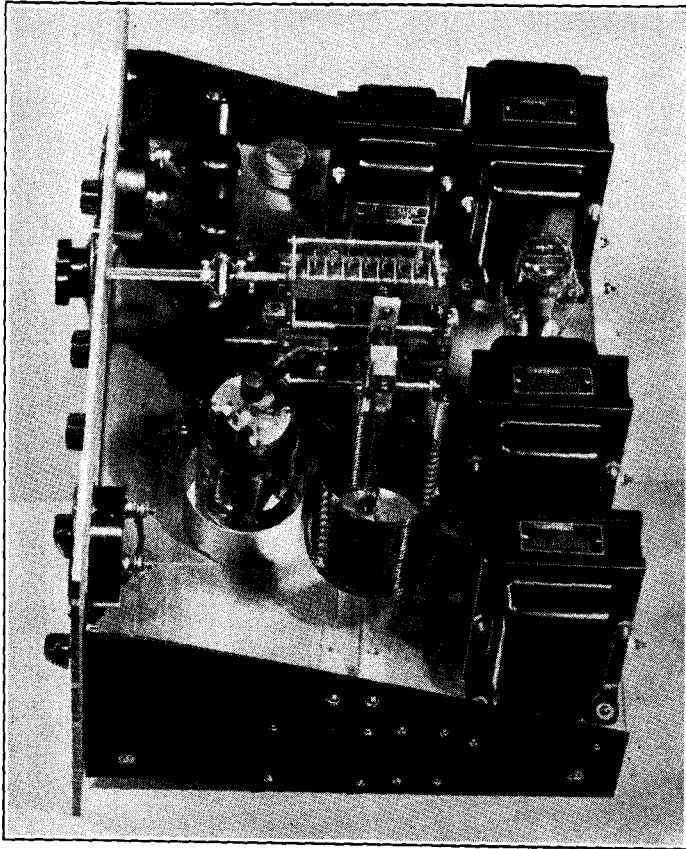

Figure 23.
LOOKING DOWN ON THE 250-
WATT RIG.

All of the above-chassis components except the bias rectifier are visible in this view. The four exciter tubes are located in line near the front of the chassis. The 813 and its plate tank circuit occupy the center portion of the chassis, while the power supply components are placed along the rear edge. The bias rectifier is hidden behind the final amplifier plate tank condenser.

The terminal marked "110 V. Common" in the diagram should be connected to one side of the a.c. supply voltage. The other side of the a.c. line should go through a s.p.s.t. "filament" switch to the terminal marked "filament 'hot'" and through another s.p.s.t. "transmit" switch to the terminal marked "H.V. 'hot'".

For c.w. work the "Cathode Modulation" terminal is connected directly to ground. If phone operation is desired this lead connects to the cathode modulator shown in figure 25. The "+ 400" terminal allows additional units, such as a speech amplifier or v.f.o. to receive their plate power from the 400-volt power supply in the transmitter proper. The power supply components are easily capable of withstanding an additional load up to 100 milliamperes.

Keying. The keying circuit is somewhat unique in that negative bias is applied to the 813 screen when the key is open. A close inspection of the wiring diagram will show that

when the key is open the screen of the 813 is connected to the 40-volt bias supply through the 150,000-ohm resistor R_{16} . When the key is closed, however, the screen is connected to the 400-volt supply through the 5000-ohm resistor R_{18} . Since R_{16} has many times the resistance of the bias load resistor R_{17} , no change in bias voltage results when the screen voltage is applied to the 813. The circuit gives exceptionally clean keying at all speeds, since the current through the key is small and the negative bias when the key is up effectively prevents emission of a "back wave."

Construction. The photographs show clearly the construction of the transmitter. The r.f. section is located toward the front of the 17 by 13 by 3 inch chassis, with the power supply components occupying the space at the rear. The exciter tank circuits are grouped around their respective tubes underneath the chassis, as may be seen in figure 23. The crackle finished masonite panel measures 19 by 10½ inches.

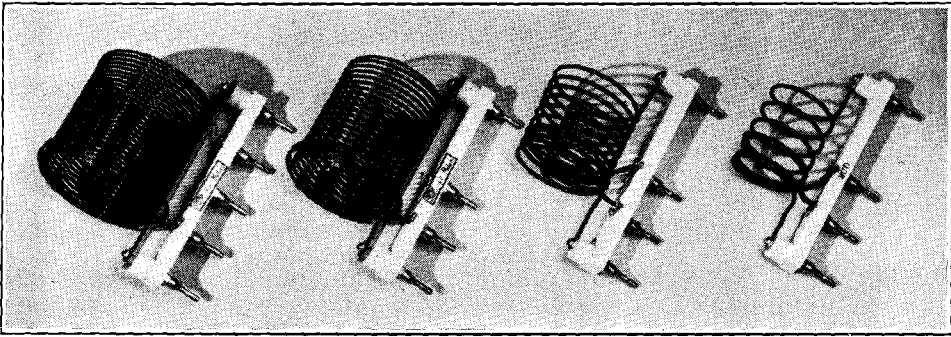

Figure 24.
THE 813 PLATE COILS.

The 80 and 40-meter coils at the left are manufactured units. The 20-meter coil has 9 turns of number 10 enameled wire and is 2½ inches in diameter and 3 inches long. The 10-meter coil is also wound with number 10 enameled wire; it has 5 turns 2 inches in diameter and is 3 inches long. Note the additional plug on the 80-meter coil which serves to connect the extra tank condenser. On each of the higher frequency coils the antenna coupling coil consists of two turns of well insulated wire pushed between the turns at the ground end of the plate winding.

Every effort has been made to keep the 813 plate circuit lead length to a minimum through grouping the tube, coil and condenser near the center of the chassis. The use of a shield made from a 3-inch coil shield around the base of the 813 above the chassis effectively eliminates any tendency toward oscillation or instability in the final amplifier which might result from capacity coupling between the grid lead within the tube and the plate tank circuit.

Operation. In operating the transmitter it is only necessary to place the proper coil for the desired band in the plate circuit of the output stage, throw the excitation switch to excite the 813 stage from the proper exciter stage, and tune the exciter and final stages to resonance as indicated by minimum plate current. The normal currents on the various stages should be about as follows: oscillator—35 ma., 40-meter doubler—20 ma., 20-meter doubler—30 ma., 10-meter doubler—40 ma., 813 grid—6-10 ma., depending on band, 813 plate—180 ma., loaded. When the transmitter is tuned up for the first time the excitation to the 813 on each band should be adjusted to give the required amount of grid current by sliding the coupling coils along the plate coils of each doubler stage.

On the two lower frequency final amplifier plate coils the antenna coupling links are fixed, and it will be necessary to use an antenna coupler having a variable coupling feature to adjust the antenna loading. On the two high frequency bands the antenna feeders may be connected directly to the transmitter antenna terminals, and the coupling

adjusted by pushing the coupling coils in or out of the plate coils.

Parallel Cathode Modulator. Parallel cathode modulation is ideally suited to modulating the output of the transmitter. In actual tests it has given greatly superior results to other systems of cathode modulating the rig. The schematic diagram of the modulator is shown in figure 25; the tube actually used in the tests was a 242-A. In this system of modu-

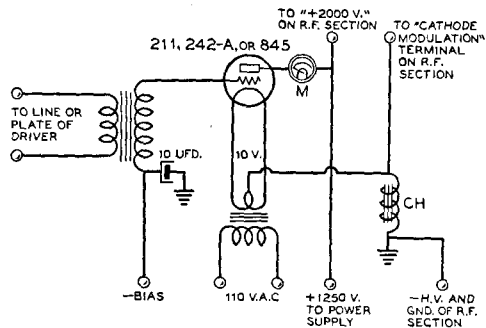

Figure 25.
PARALLEL CATHODE MODULATOR FOR
250-WATT TRANSMITTER.

The 250-watt c.w. transmitter will give a 125-watt phone carrier when modulated by this cathode modulator. The bias voltage should be adjusted so that the modulator tube plate draws 80 milliamperes. Choke CH should have 8 to 20 henrys inductance and be capable of carrying about 250 milliamperes—175 ma. plate current to the 813 and 80 ma. to the modulator. It will be necessary to reduce the power supply voltage to 1250 volts when cathode modulation is used.

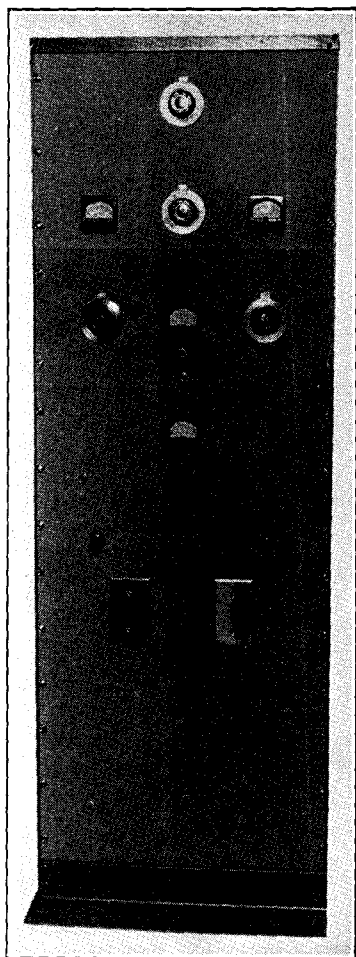

Figure 26.
400-WATT TRANSMITTER.

This five-foot relay rack contains the complete 400-watt (carrier) radiotelephone transmitter. A pair of class B 203Z's plate modulate a pair of push-pull HK254's.

lation the cathode currents of both the modulator and the modulated stage must run through a common cathode choke. Since the 813 should draw about 175 ma. (at 1250 plate volts) and the modulator tube (whether it is a 242-A, 211, or 845) should draw about 80 ma., this choke should have a current carrying capacity of 250 to 275 ma. The inductance can be from 8 to 20 henrys. The d.c. resistance of this choke should be as low as possible to reduce the biasing effect of its resistance upon both the modulator and the 813. If

the choke has a d.c. resistance of 100 ohms, the voltage drop across it will be 25 volts. Hence, this value of voltage should be subtracted from the rated bias voltage of the modulator tube at 1250 volts, and the remaining voltage applied to the lead marked "BIAS" in the schematic diagram.

It will be found that some method of reducing the excitation to the grid of the 813 will be required to obtain satisfactory operation when cathode modulated. From one-half to three ma. of grid current has been found to be correct for operation of the 813 as a cathode modulated stage. A suitable arrangement for reducing the excitation will be the substitution of a 100- μ fd. variable condenser for the fixed .0005- μ fd. unit shown at C₁₀. It was not found to give any improvement in operation of the stage under cathode modulation when the effective voltage swing upon the control and screen grids was reduced. Hence these returns need not be altered when the amplifier is to be cathode modulated.

The measured output of the stage, when adjusted for distortionless parallel cathode modulation, was found to be 125 watts. The input, 180 ma. at 1250 volts in this particular case, was 225 watts, leaving a net plate dissipation for the 813 of 100 watts. The plate efficiency is about 56 per cent.

400-WATT 10-160 M. PLATE-MODULATED PHONE

While the amateur to whom price is no item will naturally want to run a full kilowatt input plate-modulated phone when interested in high power, the amateur who is interested in economy will do better to content himself with a transmitter running in the neighborhood of 600-watts input to the plate-modulated stage. Tubes and modulation transformers for this power are widely available and quite reasonably priced, but when one goes to a full kilowatt the price of these components goes up distressingly. As there is less than 3 db difference (just barely discernible) between a kilowatt and 600 watts input, the cost of the additional power will not be justified in the case of the majority of amateurs.

Hence, for a high-power phone transmitter, one delivering about 400 watts of carrier is shown—a very economical size. If one insists upon running a full kilowatt input, it is possible to do so with substantially the same circuit by replacing the 1250-volt power supply with a 1500-volt 400-ma. supply and the

Figure 27.
EXCITER CHASSIS.

The 6L6-G harmonic oscillator and the HK-54 buffer-doubler stages are located on this deck.

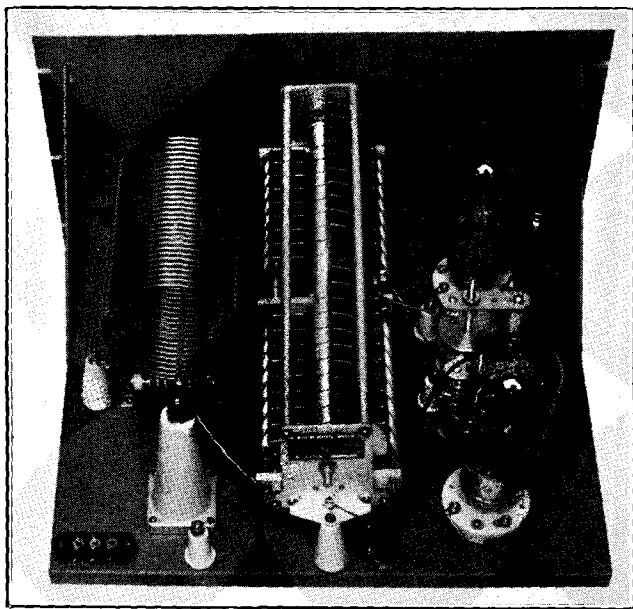
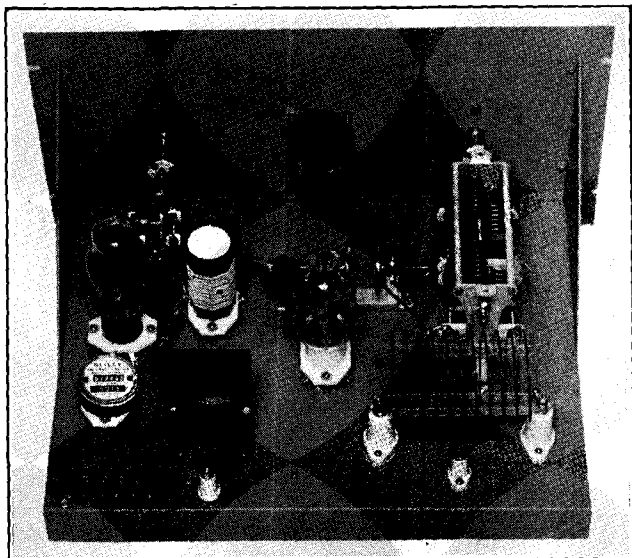

Figure 28.
THE FINAL AMPLIFIER DECK.

A shelf having a narrow lip around it is used to support the final amplifier components. The grid circuit is under the shelf.

1900-volt supply with a 2500-volt 400-ma. supply. This will permit the use of an HK254 or 100TH buffer and 250TH's or HK354D's in the modulated amplifier. Slightly greater spacing will be required for the plate tank condenser C_{18} . The 203Z's can be replaced with 822's to deliver sufficient audio at 1500 volts to modulate fully a kilowatt input on speech waveforms.

Construction of the 400-watt transmitter illustrated obviously is not for the newcomer. And the amateur who has had sufficient construction experience to warrant an attempt at the building of the transmitter will find the illustrations and wiring diagram largely self-explanatory.

The R.F. Exciter. A 6L6G harmonic oscillator driving a 35-T or HK54 neutralized

Figure 29.

WIRING DIAGRAM OF THE 400-WATT PHONE TRANSMITTER.

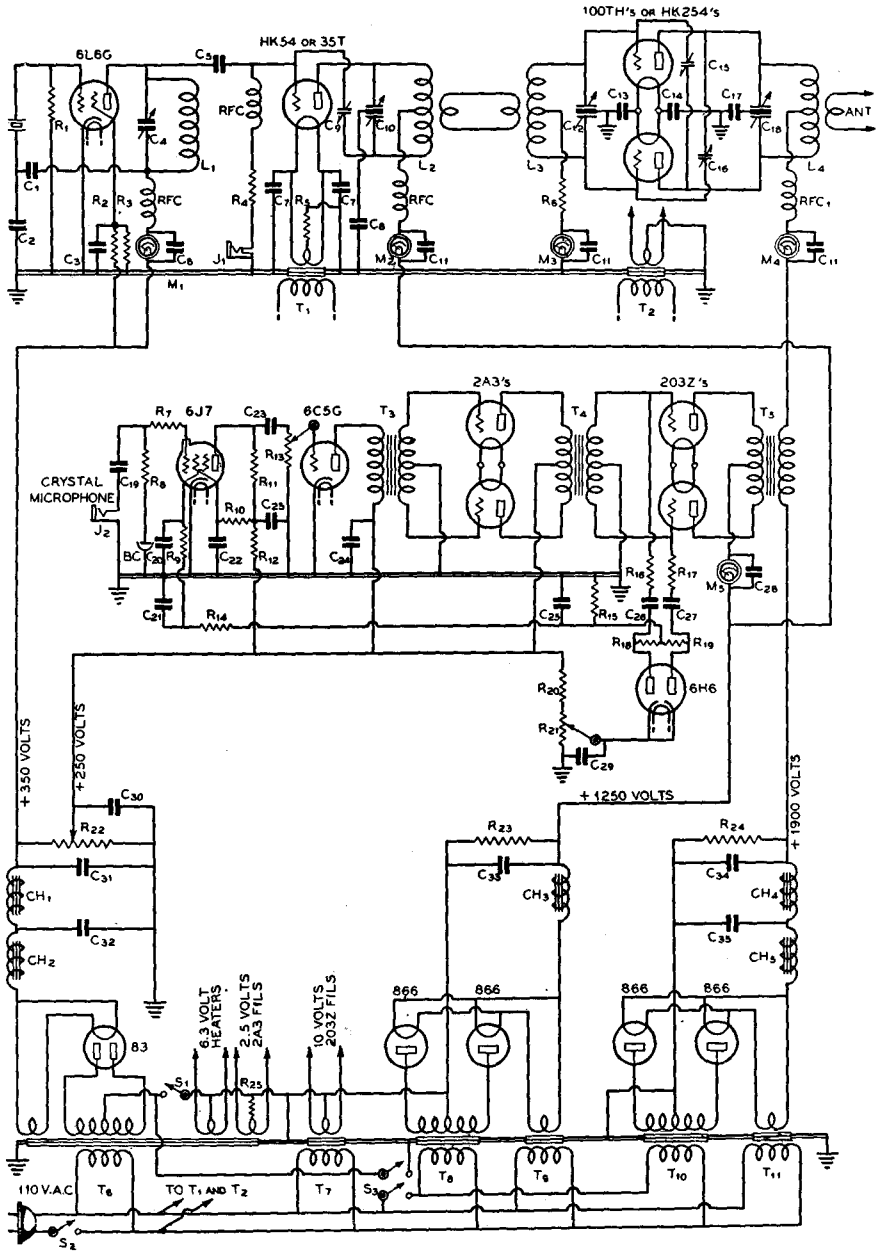

CONSTANTS USED IN FIGURE 29.

- | | | | |
|--|--|--|---|
| C ₁ —0.004- μ fd. mica | C ₂₅ —0.5- μ fd. tubular | watt | M ₄ —0-500 ma. d.c. |
| C ₂ —0.002- μ fd. mica | C ₂₆ , C ₂₇ —0.1- μ fd, tu-
bular | R ₁₂ —50,000 ohms, 1/2
watt | M ₅ —0-500 ma. d.c. |
| C ₃ —0.1- μ fd. tubular | C ₂₈ —0.02- μ fd. mica | R ₁₃ —1-meg. tapered
pot. | T ₁ —5 v. 6 amp. |
| C ₄ —50- μ fd. midget | C ₂₉ —1- μ fd. paper, 400
volts | R ₁₄ —250,000 ohms, 1/2
watt | T ₂ —5 v. 15 amp. |
| C ₅ —0.005- μ fd. mica | C ₃₀ , C ₃₁ , C ₃₂ —8- μ fd.
electrolytics, 450
volts | R ₁₅ —100,000 ohms, 1
watt | T ₃ —Push-pull input
trans. |
| C ₆ —0.02- μ fd. mica | C ₃₃ —2- μ fd., 1500 w. v.
w. v. | R ₁₆ , R ₁₇ —2 meg., 1/2
watt | T ₄ —Class-B input for
203Z |
| C ₇ —0.1- μ fd. tubular | C ₃₄ , C ₃₅ —2- μ fd. 2000
w. v. | R ₁₈ , R ₁₉ , R ₂₀ —100,000
ohms, 1 watt | T ₅ —300-watt variable
ratio modulation
transformer |
| C ₈ —0.02- μ fd. mica,
2500 volts | R ₁ —100,000 ohms, 1
watt | R ₂₁ —50,000-ohms pot. | T ₆ —440 v. each side
c.t., 250 ma., and
indicated fl. wind-
ings |
| C ₉ —Disc type neutral-
izing condenser | R ₂ —10,000 ohms, 10
watts | R ₂₂ —25,000 ohms, 50
watts | T ₇ —10 v. 7.5 amp. |
| C ₁₀ —80- μ fd. per sec-
tion, 3000-v. spac-
ing | R ₃ —50,000 ohms, 2
watts | R ₂₃ —75,000 ohms, 100
watts | T ₈ —1500 v. each side
c.t., 300 ma. |
| C ₁₁ —0.02- μ fd. mica | R ₄ —15,000 ohms, 10
watts | R ₂₄ —100,000 ohms,
100 watts | T ₉ —2.5 v. 10 amp.,
h.v. insulation |
| C ₁₂ —80- μ fd. per sec-
tion, 3000-v. spac-
ing | R ₅ —300 ohms, 10
watts | R ₂₅ —750 ohms, 10
watts | T ₁₀ —2200 v. each side
c.t., 300 ma. |
| C ₁₃ , C ₁₄ —0.1- μ fd. tu-
bular | R ₆ —2000 ohms, 50
watts | RFC—2.5 mh., 125
ma. | T ₁₁ —2.5 v. 10 amp.,
h.v. insulation |
| C ₁₅ , C ₁₆ —Disc type neu-
tralizing condensers | R ₇ —50,000 ohms, 1/2
watt | RFC ₁ —2.5 mh., 500
ma. | CH ₁ , CH ₂ —12 hy., 200
ma. |
| C ₁₇ —0.001- μ fd. mica,
5000 v. | R ₈ —1 meg., 1/2 watt | M ₁ —0-100 ma. d.c. or
meter jack | CH ₃ —5-20 hy. 300 ma. |
| C ₁₈ —75- μ fd. per sec-
tion, 1/4" air gap | R ₉ —250,000 ohms, 1/2
watt | M ₂ —0-200 ma. d.c. | CH ₄ —12 hy. 300 ma. |
| C ₁₉ —0.1- μ fd. tubular | R ₁₀ —1 meg., 1/2 watt | M ₃ —0-100 ma. d.c. or
meter jack | CH ₅ —5-20 hy., 300
ma. |
| C ₂₀ , C ₂₁ , C ₂₂ —0.1- μ fd.
tubular | R ₁₁ —250,000 ohms, 1
watt | | |

400-WATT PHONE TRANSMITTER COIL DATA

BAND	6L6G PLATE	BUFFER & FINAL GRIDS	FINAL PLATE
160	66 turns no. 22 d.c.c. 1 1/2" diam. closewound	80 turns no. 18 d.c.c. 2 5/8" diam. closewound center tap	Use 80 μ coil shunted by fixed tank condenser (see text)
80	30 turns no. 20 d.c.c. 1 1/2" diam. 1 1/2" long	36 turns no. 14 enam. 2 3/4" diam. 8 turns/in. center tap	28 turns no. 10 enam. 4 1/2" diam. 4 1/2 turns per in. center tap
40	15 1/2 turns no. 18 d.c.c. 1 1/2" diam. 1 1/2" long	20 turns no. 14 enam. 2 5/8" diam. 5 turns/in. center tap	20 turns no. 10 enam. 3 1/2" diam. 3 turns/in. center tap
20	7 1/2 turns no. 16 enam. 1 1/2" diam. 1 1/4" long	10 turns no. 14 enam. 2 1/2" diam. 2 1/2 turns per in. center tap	10 turns no. 10 enam. 3 1/4" diam. 1 1/2 turns per in. center tap
10		6 turns no. 12 enam. 1 3/4" diam. 1 1/2 turns per in. center tap	6 turns no. 10 enam. 2 3/4" diam. 1 turn/in. center tap

amplifier or doubler forms the exciter portion of the transmitter. The HK54 stage is link coupled to the grid circuit of the modulated amplifier. The HK54 is first neutralized when working as a straight amplifier on 20 meters. The neutralization will then hold close enough and be sufficiently accurate for operation on all bands. The neutralizing condenser is not disturbed when the stage is used as a doubler.

The Modulated Amplifier. The tubes in the final amplifier "load" at between 550- and 600-watts input. While a pair of HK54's or 35-T's could be run at a half kilowatt input at the plate voltage specified, such input with plate modulation is rather severe and larger tubes will give longer life. HK254's or 100TH's can be run considerably under their rated maximum plate current rating and very long life can be expected.

Sufficient coupling between the buffer and modulated amplifier can usually be obtained with a single turn link around the center of buffer plate and final grid coils. If the grid current to the modulated amplifier runs over 80 ma., the grid tank condenser can be detuned slightly. If it is impossible to obtain 80-ma. grid current on the lower-frequency bands, two-turn links will be required for those coils.

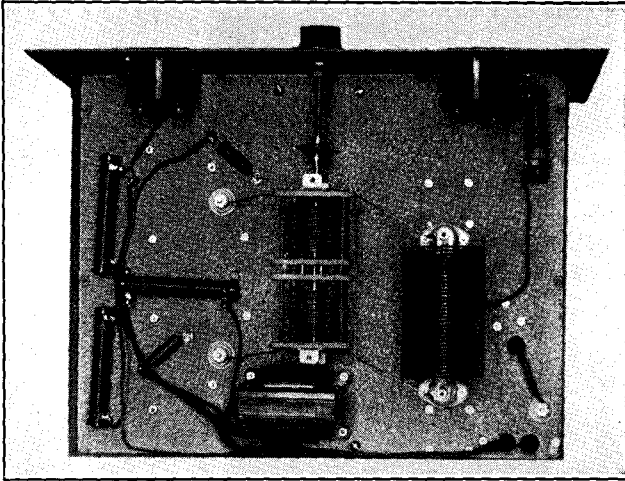

Figure 30.
BOTTOM VIEW OF THE
FINAL AMPLIFIER.
The grid coil is shielded from the plate
circuit by the metal supporting shelf.

Figure 31.
SPEECH AND MODULATOR
DECK.

The entire audio channel is contained in one rack unit. The shield on the back of the panel encloses the input jack, bias cell, grid resistor, etc., and prevents hum pickup.



To eliminate the need for a more bulky, higher capacity plate tank condenser for 160-meter operation, which would not be advisable for 10-meter operation due to the high minimum capacity, the following expedient is resorted to: the 75-meter amplifier plate coil is made slightly lower Q than optimum. The same coil is then used on 160 meters by shunting a fixed vacuum padding condenser of 50- μ fd. capacity across the tank tuning condenser. This results in a Q slightly higher than optimum for 160-meter operation, but

the compromise design of the coil results in operation substantially as satisfactory as would be obtained with separate 75-meter and 160-meter coils.

The Speech System. The speech amplifier-driver and 300-watt modulator are conventional except for the incorporation of automatic peak compression to allow a higher average percentage of modulation without the danger of overmodulation on occasional loud voice peaks. The delay action (percentage modulation at which compression starts) can

Figure 32.
350- AND 1250-VOLT POWER
SUPPLIES.

The low voltage power supply components are located toward the right edge in this rear view.

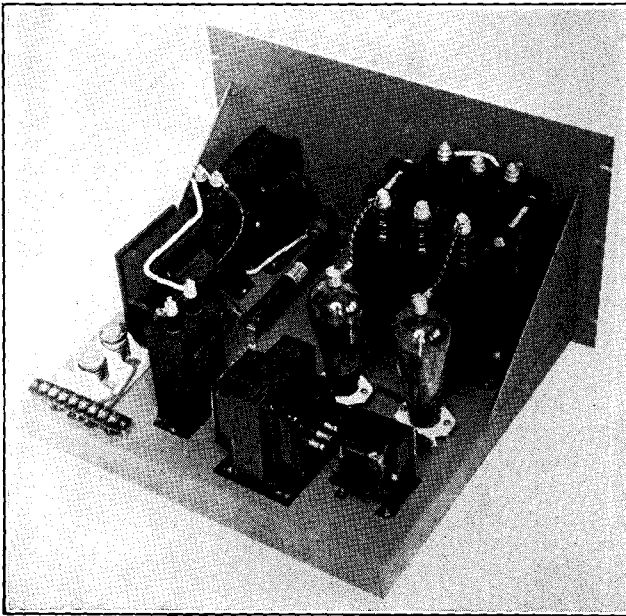
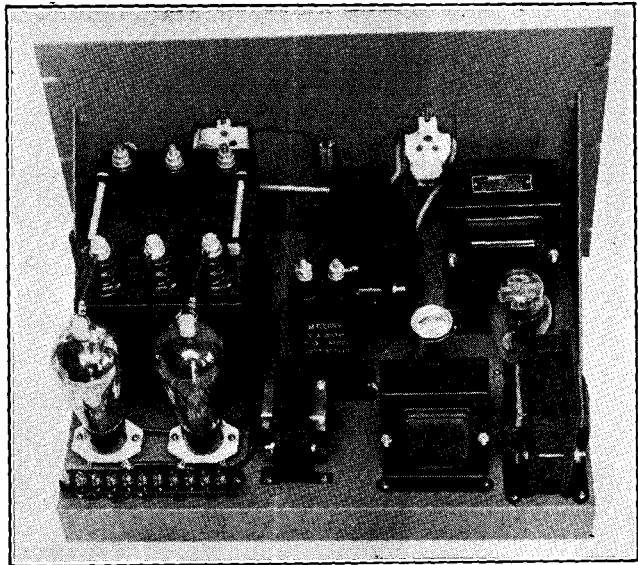

Figure 33.
THE 1900-VOLT POWER
SUPPLY.

This power supply feeds the modulated amplifier stage. It has a two-section filter in order to remove all carrier hum.

be adjusted by means of the potentiometer R_{21} . The modulators are fed from the same 1250-volt supply that furnishes plate voltage to the buffer amplifier.

All leads and components in the 6J7 first speech stage should be shielded to prevent grid hum and possible feedback. TZ40's can be substituted for the 203Z's by utilizing 9

volts of fixed battery bias. The tubes will supply sufficient output for complete modulation of 600 watts input when voice is used, though they will not last as long as 203Z's.

The Power Supplies. The 350-volt and the 1250-volt power supplies are built on one chassis; the 1900-volt supply has a chassis of its own. To keep the carrier hum at a very

low level, a two-section filter is used in the 1900-volt supply feeding the modulated amplifier. As the push-pull modulators and the r.f. driver stage are relatively insensitive to a moderate amount of plate supply ripple, a single-section filter suffices for the 1250-volt supply.

While it is desirable to have six meters to facilitate reading of all important grid and plate current values simultaneously, it is possible to get by with fewer meters by incorporating metering jacks. Such jacks should be placed in filament return leads rather than in plate leads when the plate potential is over 500 volts. Meters in filament return jacks read combined grid and plate current, and the grid current should be subtracted from the meter reading to determine the actual value of plate current.

Construction. The mechanical construction and lay-out of components can be observed in the various illustrations. All chassis

measure 13"x17"x1½" and have end brackets to strengthen them. All panels are of standard 19" width, with heights as follows: final amplifier 12¼", exciter 8¾" all others 10½".

Operation. Initial tuning of as elaborate and expensive a transmitter as this should preferably be done by an experienced amateur familiar with tuning and adjustment of high-power phone transmitters. General considerations regarding transmitter tuning and adjustments are covered in the transmitter theory chapter. The following meter readings are typical of normal operation:

6L6G cathode current: 35 to 60 ma.
Buffer grid current: 10 to 15 ma.
Buffer plate current: 50 to 75 ma.
as buffer; 80 to 100 ma. as doubler.
Final plate current: 300 to 325 ma.
203Z plate current: 75 to 100 ma.
resting, swinging up to approximately
200 ma. on voice peaks.

CHAPTER SEVENTEEN

U. H. F. Communication

An old and still valid definition of *ultra-high frequencies* is: *those frequencies which are not regularly returned to the earth at large distances.* Under this definition, the limit between *high* and *ultra-high* frequencies shifts with the sunspot cycle. From 1935 to 1940, the 30 megacycle band was regularly useful on winter days and on spring and fall afternoons, but from 1941 through 1945 it is due to become much more erratic. That is not to say, however, that higher frequencies are useless; for the very fact of limitation on distance covered is in itself a blessing for crowded bands, and brings back the old thrill of reaching out to difficult distances. There is good reason for the current trend—or landslide—to these very short wavelengths. In order to promote a better understanding of transmission methods, the several types will be classified and discussed.

Propagation

Direct Communication. *Horizon*, local, or direct point-to-point reception refers to two points between which there is no obstruction to the waves. This might be a mile or two hundred, depending on the altitude of the antennas and the nature of the intervening land.

The distance to the horizon is given by the approximate equation $d = 1.22 \sqrt{H}$, where the distance d is in miles and the antenna height H is in feet. This must be applied both to the transmitting and receiving antennas. Actually, diffraction of the signal around the spherical earth makes the field strength decline as if the earth's diameter were $\frac{4}{3}$ of the actual figure.

In the case of ground as smooth as a billiard ball, there is not actually a discontinuity of the signal at the horizon; that is, an airplane taking off beyond and below the horizon would begin to encounter some signal below an altitude actually in sight of the transmitting antenna.

Ground Wave. Because the signal is heard consistently beyond the horizon, the term *ground wave* is usually applied out to 30 or more miles—and much longer when one or both antennas are high. The waves are propagated, presumably, by *diffraction* or dispersion around the curve in the earth's surface in the same way as light is diffracted around a sharp corner. Out to this distance, the transmitting and receiving antennas give best results when both are either vertical or horizontal.

Low Atmosphere Bending. *Pre-skip*, extended ground wave, refracted-diffracted, or low atmosphere bending dx mean essentially the same thing. All refer to distances out to perhaps 200 or 300 miles, in the absence of unusual aurora or magnetic activity. Beams are pointed close to the direct line between the stations. The first two terms refer to the distance but not to the method by which the transmission is accomplished, and presumably differ from the local or ground wave type only because the greater distance is covered as a result of more power, better antennas, or more sensitive receivers.

Low atmosphere bending, on the other hand, in the narrow sense refers to pushing the signal over at the same distance with the aid of a temperature discontinuity or inversion in the lower atmosphere that bends the waves slightly downward, rather than just simple brute force methods implied by the other terms. It is frequent along the west coast of the U. S. A. and is prevalent in the summer in the east. It involves long slow fading, although close in where weak direct waves are also heard, fading can be violent. It is more apt to occur on days when there are stratus clouds than on cool, clear days with a deep blue sky. Often, evenings are better than days, due to the cooling of the earth. It is attributed to a discontinuity in the normal decrease of temperature with increasing height above the earth. The discontinuity or *temperature inversion* often occurs about one

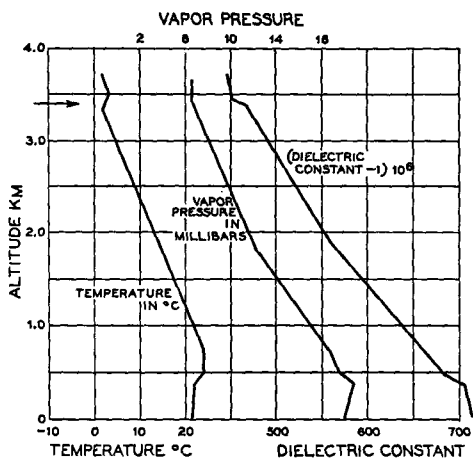

Figure 1.

ILLUSTRATING TYPICAL TEMPERATURE INVERSION AT 3.4 KM.

Air mass boundary heights shown by U.S. Weather Bureau free air data, compared to measured heights from frequency sweep patterns on ultra high frequencies.

mile up, and is generally predictable from weather information several days in advance. It produces no noticeable skip, the signal normally being diffracted around the curving earth and assisted by some bending above the surface. It does not appear to depend on the sunspot cycle. In general, it calls for similar antenna polarization or orientation at both ends for best results, whereas in ionosphere types of transmission it makes very little difference whether antennas are horizontal or vertical.

Aurora-type DX. The same and longer distances can be reached below 60 megacycles during periods of visible displays of the aurora borealis, and during magnetic disturbances. This has been termed *aurora-type dx*. These conditions reach a maximum somewhat after the sunspot cycle peak, possibly because the spots on the sun are nearer to its equator (and more directly in line with the earth) in the latter part of the cycle. Magnetic storms are often accompanied by ionosphere storms which churn up the regular layers and make reception on low frequency bands difficult. This condition, however, has often brought about "skipless" five and ten meter contacts, usually completed by pointing beam antennas in a northerly direction, regardless of the true direction of the other stations.

Short Skip. The lower of the two more important ionosphere layers is the *E* region. This accounts for 160-meter and broadcast dx at night. Sometimes a *sporadic* condition exists in this layer, the height of which is usually about 110 kilometers (68 miles) above sea level, which will reflect the highest frequency waves that return to the earth. One hop can be as long as 1200 miles, or slightly longer with antennas producing good low angle radiation and reception (below 3 degrees). Occasionally 1300 or 1350 miles can be covered, possibly with the help of low atmosphere bending at each end. *Sporadic-E* layer reception may occur at any time but is much more prevalent from late April to early September, and slightly more apt to occur in the late morning and early evening. Skip as short as 310 miles on 56 megacycles in one instance indicates that on an exceptionally good day, $2\frac{1}{2}$ meter (112 megacycle band) signals might have been heard erratically at 1200 miles. The *sporadic-E* layer is spotty, accounting for contacts in definite areas, and permitting only a few days of double-hop reception. The number of favorable hours for ten and five meter short skip is expected to decrease for several years, but improved equipment is making possible five meter work, especially, under relatively poor conditions.

Horizontal antennas are every bit as good as verticals for this work, apparently, and the polarization of the transmitting antenna need not be the same as that used for receiving. Because u.h.f. antennas may be a number of wavelengths high, their vertical plane pattern may contain several angles at which transmission or reception is difficult or impossible; a null for a horizontal is at the same angle as a maximum for a vertical antenna, and the reverse, thus accounting for widely varying signal strengths should the waves come in at one of these critical angles. Beams show some directivity on *sporadic-E* reception but generally are not as sharp as in pre-skip dx, possibly due to better signal strength or to an angle of reception several degrees above the horizontal.

Long Skip. The higher of the two major reflecting layers of the ionosphere is the *F* region. This accounts for long-skip signals coming down as far away as 2200 miles in a single hop, with multiple hops common. The silent or skip zone may be around 1600 miles. On winter days, this layer accounted for ten meter (30 megacycle) transmission during the favorable part of the sunspot cycle. There was some evidence of five meter (56 megacycle) transmission by this method in

Figure 2.
TYPICAL U.H.F. PROPAGATION CHARACTERISTICS.

Calculated curves for air boundary reflected and earth refracted-diffracted components, in both vertical and horizontal polarization. Short doublet antennas, 1 kw. power radiated, wavelength 4.7 meters, ground conductivity 5×10^{-11} E.M.U., and dielectric constant 80 for sea water. Height of transmitting antenna 42 meters, of receiving antenna 5 meters, air boundary height 1500 meters, effective radius of earth 8500 kilometers.

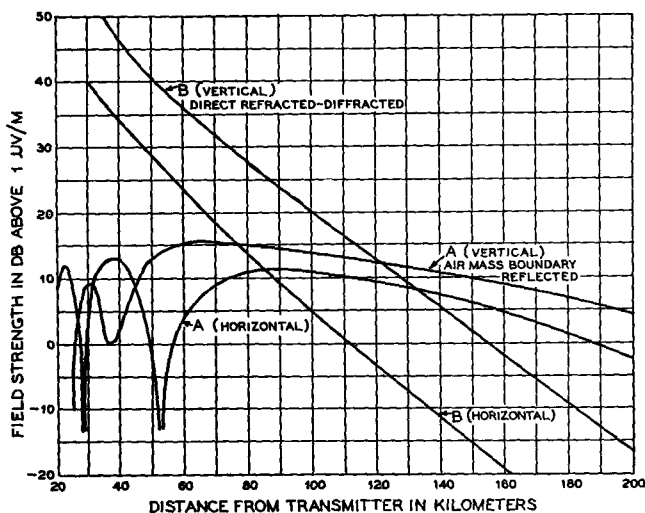

1937 and 1938 but ionosphere and sunspot records suggest that it may be 1947 or so before there is another favorable time for this kind of work. Ten meter signals are likely to suffer from less consistent *F*-layer reflections for several years following 1941.

Sometimes, this layer builds up in a way that if a beam antenna is aimed southeast in the morning or southwest in the afternoon, stations can be contacted within the normal skip band by bouncing the waves off of the edge of a layer located farther south.

Equipment Considerations

Years ago, tube bases were removed to get down to 100 meters, but experimentation is making $1\frac{1}{4}$ meters (224 megacycle band) as easy as 10 meters was a few years ago. Limits in the use of triode or pentode tubes are being approached, however, which may force further tube and circuit development. Beam tetrode tubes are now available to provide a kilowatt on $2\frac{1}{2}$ meters, and good output on $1\frac{1}{4}$ meters. Triodes are now available to turn out considerable power on $\frac{3}{4}$ meters (400 megacycles). The tuned circuit—the basis of radio—is undergoing changes and may be replaced by *cavity resonance* at micro-waves.

Even a perfect circuit must be coupled to something to be useful. A vacuum tube grid presents an apparent low resistance to the tuned circuit at short wavelengths. At 60 megacycles, this is about 2300 and 2500 ohms for the 6L7 and 1852, compared with 54,000 for the acorn 954 and 956. Normal receive-

ing pentodes such as the type 57 have a relatively low input resistance even at 14 megacycles, reducing the effectiveness of the best circuit. With increasing frequency, there is a point for each tube where the output is no larger than the input, adding its shot-effect noise to the signal arriving in its plate circuit. This makes necessary the use of acorn tubes above a certain frequency.

In a properly designed receiver, thermal agitation in the first tuned circuit is amplified by subsequent tubes and predominates in the output. For good signal-to-set-noise ratio, therefore, one must strive for a high-gain r.f. stage exclusive of regeneration. Hiss can be held down by giving careful attention to this point. A mixer has one-third of the gain of an r.f. tube of the same type; so it is advisable to precede a mixer by an efficient r.f. stage.

The frequency limit of a transmitting tube is reached when the shortest possible external connections are used as the tuned circuit, except for abnormal types of oscillation. Generally, amplifiers will operate at higher frequencies than will oscillators. For satisfactory efficiency in an amplifier, it is important to place all tuning condensers so that leads and condenser frame have very little inductance. Otherwise, such leads should be increased to an electrical half wavelength. Wires or parts are often best considered as sections of transmission lines rather than as simple resistances, capacitances or inductances.

Transmission Line Circuits. At increasingly higher frequencies, it becomes progressively more difficult to obtain a satisfactory

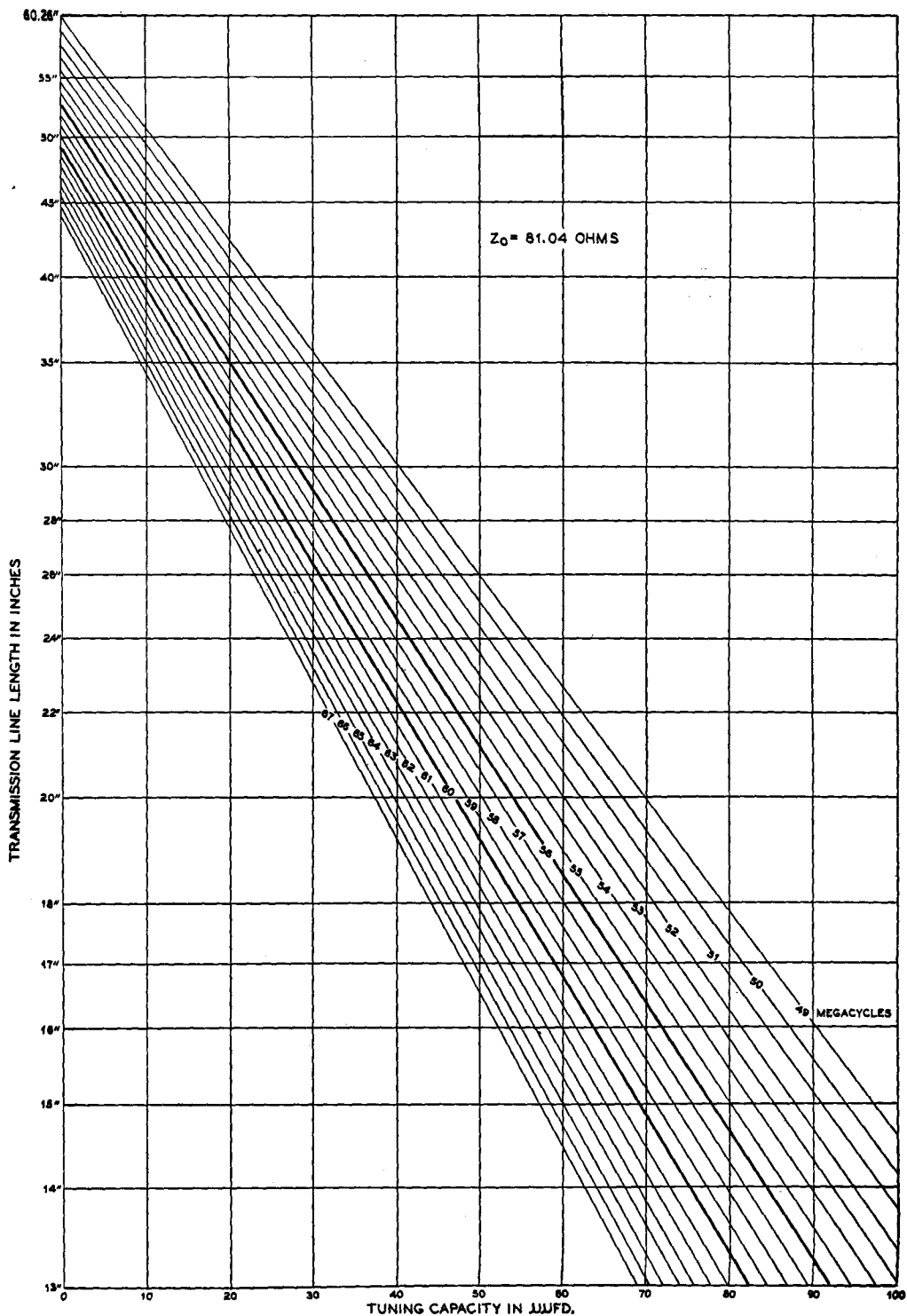

Figure 3.
CHART SHOWING CAPACITY REQUIRED TO
RESONATE SHORTENED LINES OF 81 OHMS
SURGE IMPEDANCE.

See text for method of converting to other frequencies and surge impedances. Chart applies directly to coaxial lines and, through conversion (see text), to open-wire lines.

amount of selectivity and impedance from an ordinary coil and condenser used as a resonant circuit. On the other hand, quarter wavelength sections of parallel conductors or concentric transmission line are not only better but also become of practical dimensions.

Full quarter wavelength lines resonate regardless of the ratio of diameter to conductor spacing—with due allowance for the length of the shorting disc or bar. Substantial open-end impedance, Z_s , and selectivity, Q , can be built up with lines less than a quarter wavelength, loaded with capacity at the open end, provided that the condenser is an excellent one—preferably copper plates attached to the conductors with no dielectric losses. This is more important, of course, in lines used for frequency control that are lightly loaded. Lines also can be tuned (if not loaded with capacity) by substituting a variable condenser for the shorting bar or disc.

Any unintentional radiation from a coupling link, or resistance coupled into the line, will reduce its effectiveness. Lines that are much shorter than a quarter wave may require considerable capacity to restore resonance; the amount of required capacity can be reduced by using a line with a higher surge impedance—that is, wider spacing for two-wire lines, or a smaller inner conductor for a given outer conductor of a coaxial line. For greatest selectivity, or oscillator frequency control, the conductor *radius* should be about a quarter of the center-to-center line spacing or, in a coaxial, the inner conductor should be a quarter of the diameter of the outer pipe. For high impedance, ordinarily desired anywhere except for oscillator frequency control, the ratio can be eight-to-one or higher, thus reducing the necessary loading capacity on short lines.

Very large spacing is undesirable on open wire lines where the shorting bar may radiate so much that the tuned circuit has radiation resistance coupled into it and the impedance is reduced. Preferably, the active surfaces of lines should be copper or silver. A thin chrome plate over copper is also fairly satisfactory, as is an aluminum surface. The conductivity of the center conductor in a coaxial tank is much more important than that of the outer conductor, due to its smaller diameter.

Tuning Short Lines. Tubes hooked on to the open end of a transmission line provide a capacity that makes the resonant length less than a quarter wavelength. The same holds true for a loading condenser. How much the line is shortened depends on its surge impedance. It is given by the equation $\frac{1}{2}\pi fc = Z_0 \tan l$, in which $\pi = 3.1416$, f is the frequency, c the capacity, Z_0 the surge impedance of the line, and $\tan l$ is the tangent of the electrical length in degrees.

The surge or characteristic impedance of such lines can be calculated from the equations: $Z_0 = 276.3 \log_{10} (D/r)$ ohms for two-wire lines and $Z_0 = 138.15 \log_{10} (b/a)$ ohms for coaxial lines, where Z_0 is the surge impedance, \log_{10} refers to the common logarithm, D and r refer to center-to-center spacing and conductor *radius* of two wire lines, b and a are outer conductor inner diameter and inner conductor outer diameter for coaxial lines. Charts showing characteristic surge impedance for parallel conductors and for coaxial lines may be found in chapter 20, figures 12 and 13.

The capacitive reactance of the capacity across the end is $\frac{1}{2}\pi fc$ ohms. For resonance, this must equal the surge impedance of the line times the tangent of its electrical length (in degrees, where 90° equals a quarter wave). It will be seen that twice the capacity will resonate a line if its surge impedance is halved; also that a given capacity has twice the loading effect when the frequency is doubled.

The accompanying chart (figure 3) can be used to determine the necessary line length or tuning capacity. For 112 megacycles, use the 56 megacycle curve but divide the capacity and line length scales by two. That is, if an 81.04 ohm line 30 inches long will tune to 56 megacycles with 28.20 $\mu\mu\text{fd}$. capacity, an 81.04 ohm line 15 inches long will tune to 112 megacycles with a 14.10 $\mu\mu\text{fd}$. condenser. Likewise, a 60 inch line of the same impedance will tune to 28 megacycles with 56.40 $\mu\mu\text{fd}$. This sounds like a lot of condenser, and can be reduced to 28.20 $\mu\mu\text{fd}$. by doubling the line impedance to 162.08 ohms. But in any event this circuit will outperform a coil both as to gain and selectivity. The capacities mentioned include circuit capacity; in the case of a mixer preceded by an r.f. stage, this will amount to about 10 $\mu\mu\text{fd}$. with acorn tubes, allowing 3 $\mu\mu\text{fd}$. for condenser minimum.

Coupling Into Lines. It is possible to couple into a parallel rod line by tapping directly on one or both rods, preferably through blocking condensers if any d.c. is

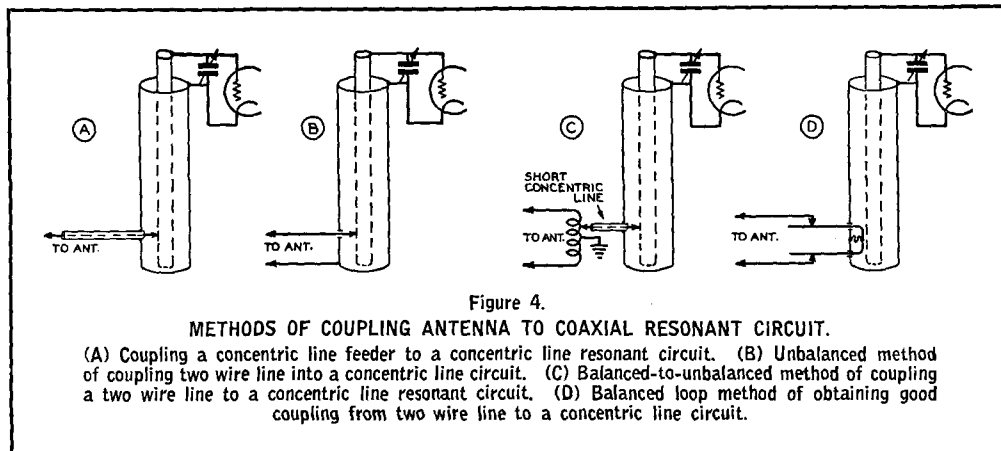

present. More commonly, however, a "hairpin" is inductively coupled at the shorting bar end, either to the bar or to the two rods, or both. This usually results in a balanced load. Should a loop unbalanced to ground be coupled in, any resulting unbalance reflected into the rods can be reduced with a simple Faraday screen, made of a few parallel wires placed between the hairpin loop and the rods. These should be soldered at only one end and grounded.

An unbalanced tap on a coaxial resonant circuit can be made directly on the inner conductor at the point where it is properly matched. For low impedances such as a concentric line feeder, a small one-half turn loop can be inserted through a hole in the outer conductor of the coaxial circuit, being in effect a half of the hairpin type recommended for coupling balanced feeders to coaxial resonant lines. The size of the loop and closeness to the inner conductor determines the impedance matching and loading. Such loops coupled in near the shorting disc do not alter the tuning appreciably, if not over-coupled. Various coupling circuits are shown in figure 4.

Frequency Measurement

At ultra-high frequencies, Lecher wires or frames can be used to determine the approximate frequency of an oscillator; a crystal harmonic or receiver oscillator harmonic can then be used for closer measurement. A ten meter receiver with 1.6 Mc. i.f. will pick up an image 3.2 Mc. from a ten meter signal. If a five meter signal is picked up while the receiver is still tuned to ten meters, signal and image will be only 1.6 Mc. apart, and the dial setting will be incorrect by one-half of the i.f.

To explain, a 29-Mc. signal would be heard with the receiver oscillator higher in frequency by the amount of the i.f., or 30.6 Mc., with the dial reading 29 Mc. The image would come in when the oscillator is tuned to 27.4 Mc., at which time the dial will read 25.8 Mc. On the second harmonic, however, the dial set at 29 Mc. will place the 30.6 Mc. oscillator harmonic at 61.2 Mc., and bring in signals 1.6 Mc. lower, or on 59.6 Mc. The sub-harmonic of this is 29.8 Mc., or one-half of the i.f. higher than the dial setting of 29.0 Mc.

A 59.6 Mc. signal would also come in as an image when the receiver dial reads 27.4 Mc., or only one times the i.f. rather than twice as on the fundamental. At this setting, the oscillator is on 29 Mc., and its second harmonic is on 58 Mc., producing a 1.6 Mc. i.f. by beating against the 59.6 Mc. signal. The above is based on the assumption that the oscillator frequency is higher than the received signal, as is customary in commercial receivers. With a little care, this method can be used to spot bands as well as to place a transmitter in a band with fair accuracy.

Lecher Wire Systems. A Lecher wire measuring system consists of a pair of parallel wires one or more wavelengths long, short circuited at one end to provide a pick-up loop which can be coupled to the tuned circuit of a transmitter or receiver. The wires can be no. 12, approximately one inch apart. The shorter wavelength units can be stretched on a long wooden framework if no supports or insulators are used in the measuring range.

Energy induced in the parallel wires establishes standing waves of voltage and current along the wire when resonance is established with a shorting bar. The sliding bar (see figure 5) is moved along the wires until two successive points are located which

Frequency (Mc.)	¼ Wave (inches)	½ Wave (inches)
56	52.7	105.5
57	51.8	103.6
58	50.9	101.8
59	50.0	100.1
60	49.2	98.4
112	26.4	52.7
113	26.1	52.3
114	25.9	51.8
115	25.7	51.3
116	25.4	50.9
224	13.2	26.4
226	13.1	26.1
228	12.9	25.9
230	12.8	25.7
400	7.4	14.8
410	7.2	14.4

FREQUENCY VS. WAVELENGTH

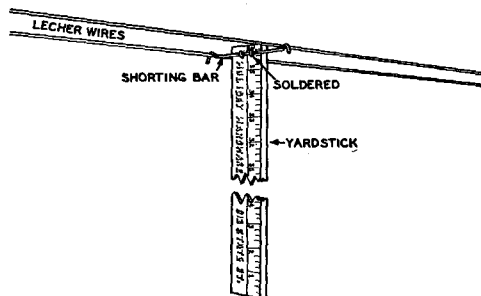

Figure 5.
LECHER WIRE MEASURING EQUIPMENT.

The wires are spaced about $1\frac{1}{2}$ inch and pulled taut. "Bumps" will appear exactly $\frac{1}{2}$ wavelength apart on the wires as the jumper is slid along. The wires may be coupled to the oscillator under measurement by means of twisted line.

cause the oscillator under test to draw more plate current or go out of oscillation. The distance between these two points is a half wavelength. This can be converted into meters by multiplying the length in feet by 0.61 (actually 0.6096) or the length in inches by 0.0508. For microwaves, the length in inches is usually converted to wavelength in centimeters by multiplying by 5.08. These factors convert to the metric system and take care of the fact that the points are one-half rather than one wavelength apart. An accuracy of only 1 per cent or so can be expected; receiver or oscillator harmonics should supplement these measurements for greater accuracy.

Lecher Frames. For a quick check of wavelength, any two parallel wires or rods can be used as a quarter wave Lecher frame. The open ends can be held near the oscillator while a screw driver or other shorting bar is run down the rods. The oscillator frequency will change and the output will dip when the Lecher frame crosses resonance. This point will give a close approximation of the frequency if half the shorting bar length plus one conductor from the shorting bar to the end near the oscillator is taken as 0.95 of a quarter wavelength. Accuracy to better than 3 per cent can be expected with this system.

Receiver Theory

So long as small triodes and pentodes will operate normally, they are generally preferred as u.h.f. tubes over other receiving methods that have been devised. However,

the input capacity of these tubes limits the frequency to which they can be tuned. The input resistance, which drops to a low value at very short wavelengths, limits the stage gain and broadens the tuning. The effect of these factors can be reduced by tapping the grid down on the input circuit, if a reasonably good tuned circuit is used.

A mixer or detector can have a gain only of about one-third of that for the same tube used as an r.f. amplifier, so that for gain and principally for satisfactory signal-to-noise ratio, a good r.f. stage is advisable. The first tube in a u.h.f. receiver is most important in raising the signal above the thermal agitation noise of the input circuit, for which reason small u.h.f. types are definitely preferred. Regeneration increases over-all gain without improving the signal-to-noise ratio, provided that increased selectivity in the regenerative stage does not determine the receiver's over-all selectivity.

Superregenerative Receivers. A very effective simple receiver for use at ultra-high frequencies, if properly adjusted, is the superregenerative receiver. The theory of this type is covered in Chapter 4 and is illustrated in Chapter 18.*

Superheterodyne Receivers. Although they involve the use of more tubes, superheterodyne receivers are somewhat less critical to adjust properly than the superregenerative type. They have the advantages of not causing broad interference locally, and have

* For a more extensive study of its basic theory and adjustment, see articles by Frederick W. Frink in RADIO for March and April, 1938.

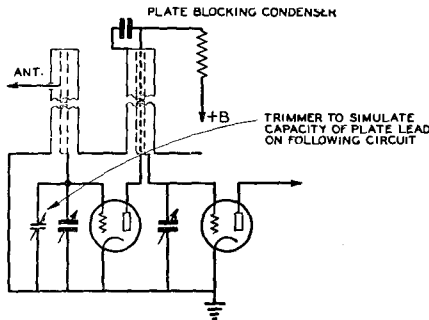

Figure 6.
CONCENTRIC TANK CIRCUITS AS USED
IN ULTRA HIGH FREQUENCY RE-
CEIVERS.

Concentric tanks are best at very high frequencies as they have a much higher impedance at these frequencies.

greater selectivity. The main problem in them is to obtain adequate oscillator voltage injection so that the conversion gain is satisfactory. Screen or suppressor injection requires a strong oscillator if the mixer tube's grid circuit is properly shielded; if it is not, leakage to the control grid will provide grid injection. The latter (often recommended by tube manufacturers for best gain on ultra-high frequencies) results in greatest "pulling" but this can be eliminated by use of a high intermediate frequency and proper construction.

Cathode injection is not recommended by manufacturers because a long cathode lead increases the *transit time effect* and decreases the apparent input resistance of the tube; however, at very high frequencies, several good receivers have used this variation of grid injection by having the mixer cathode clip tap directly on the oscillator tank with very little inductance from the tap to ground and to the grid and plate r.f. return leads.

A stable, hum-free oscillator is necessary in a u.h.f. superheterodyne. Small tubes like the acorn 955 or the HY615 are satisfactory for this purpose. Heater chokes may reduce hum in cathode-above-ground circuits. Doubler-oscillator circuits or a very high i.f. can be used to reduce the oscillator frequency. Crystal controlled oscillators can be used when the i.f. channel is a tunable receiver.

Here again, an r.f. stage is advantageous to prevent the oscillator from radiating, and to obtain the best signal-to-set-noise ratio, the gain of the r.f. stage being higher than for the mixer, with its output riding over subsequent noise in the receiver. The use of sec-

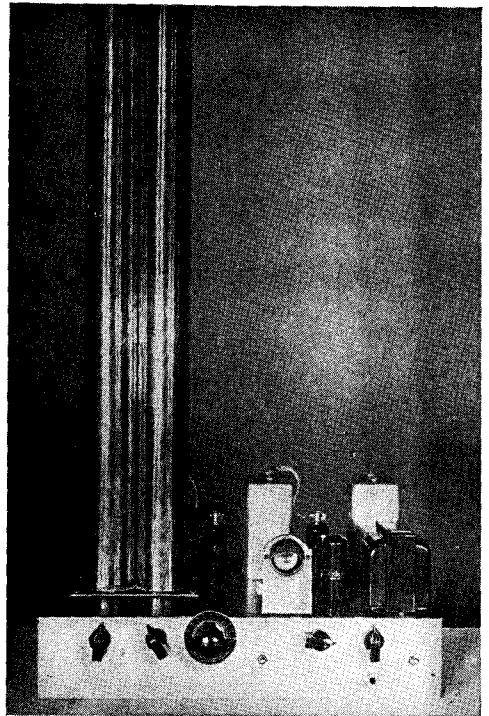

Figure 7.
SUPERHETERODYNE FOR 56 MC. USING
CONCENTRIC TANK CIRCUITS.

The acorn tubes used in the high frequency stages are located under the chassis.

tions of transmission lines instead of coils can improve gain and simplify adjustment and ganging.

High signal input resulting from the use of a carefully designed antenna and feed line, and properly adjusted coupling to the input circuit of the receiver, are essential in obtaining maximum performance. Balanced or shielded feed lines, to reduce pick-up of undesired outside noise, are helpful. The best antenna systems are generally those that are most effective at angles close to the horizontal.

Transmitter Theory

At ultra-high frequencies, simple but well constructed stabilized oscillators coupled directly to the antenna are satisfactory for c.w. at 28 and 56 megacycles, and for modulated waves above 60 Mc. Master oscillators can be built to drive modulated amplifiers with adequate frequency stability. Where highly stable transmission is desired, however, the tendency among amateurs is to use a crystal

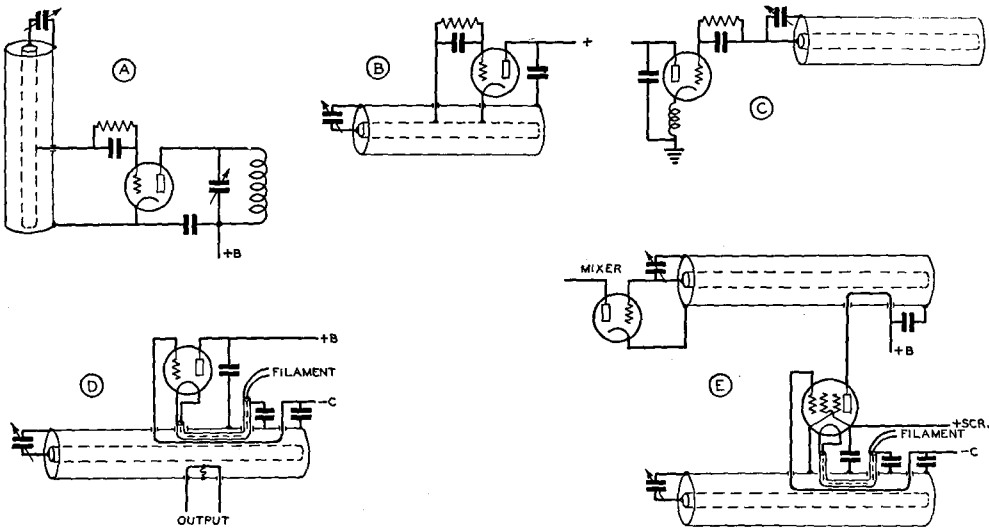

Figure 8.

TYPICAL COAXIAL LINE CONTROLLED OSCILLATOR CIRCUITS.

(A) Concentric line tuned grid, coil tuned plate oscillator. (B) Cathode-above-ground type oscillator circuit with concentric line. (C) Single control oscillator circuit without tap on line, although stability can be increased by tapping the grid down. (D) RCA's oscillator circuit used in a broad band transmitter having good stability, requiring only one tuned circuit. (E) Similar to (D) but showing pentode tube and balanced loop coupling to mixer stage. All coaxial tanks are shorted at the end opposite the tuning condenser.

or electron coupled oscillator at a lower frequency, followed by frequency multipliers. This arrangement provides good stability under modulation but may drift in frequency more with heating than will a well designed transmission-line-controlled u.h.f. oscillator.

Single-ended oscillator and amplifier stages are often used, but there is reason to prefer push-pull circuits in order to reduce tube capacity across resonant circuits, to obtain balanced arrangements, and to reduce the importance of the cathode leads.

In oscillators, it is highly important to have a lightly loaded, high Q circuit to control the frequency. Such circuits can substantially reduce hum, drift and frequency modulation. Partial neutralization is a help. A concentric line (when not used with a poor loading condenser) with loose coupling to the grid of the oscillator tube will turn out a good job in a single-ended or push-pull circuit. More commonly, parallel rods are used in push-pull circuits, particularly in plate circuits; if they have a large diameter, remarkably good stability can be obtained.

Due to the appreciable length of cathode leads in terms of wavelength at ultra-high frequencies, push-pull transmitters sometimes become inoperative or unusually inefficient as the frequency is raised. A section of small-

size transmission line electrically a half wavelength long can be used to interconnect filaments and place them at ground potential, as indicated by figure 13. The shorting bar can be moved to the place where output is greatest or, in some cases, to the only place where oscillation will occur. This application of resonant lines should not be confused with the tuned-plate tuned-grid circuit in which the grid line is moved around to the filament and adjusted to provide the reactance common to grid and plate circuits necessary to maintain oscillation.

Neutralizing condensers are often used on

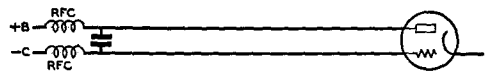

Figure 9.

SIMPLIFIED SCHEMATIC OF SINGLE TUBE OSCILLATOR USING RESONANT LINE WITH PARALLEL CONDUCTORS.

Tubes with an amplification factor of more than 10 are not well suited for use in this circuit. The blocking condenser serves as a shorting bar when frequency adjustment is required. The amount of feedback can be controlled over certain limits by varying the bias resistor or bias voltage.

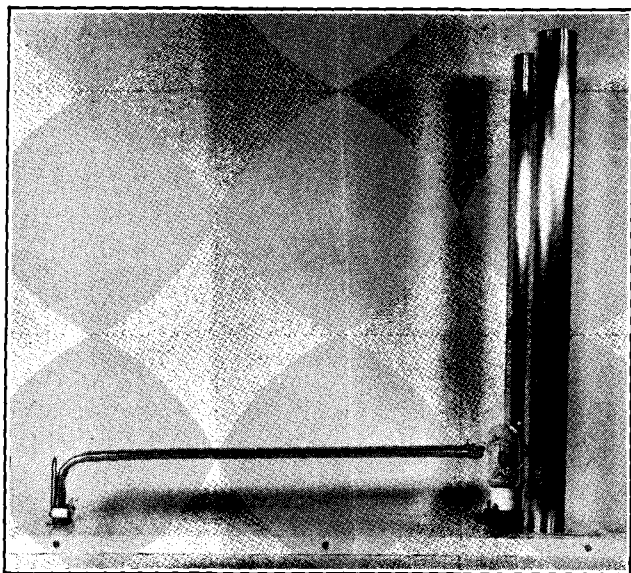

Figure 10.
TYPICAL U.H.F. PUSH-PULL
OSCILLATOR USING CLOSE-
SPACED RESONANT PIPES
FOR FREQUENCY CONTROL.
A "Twin-30" special u.h.f. dual
triode is used and permits high
efficiency at 224 Mc.

u.h.f. oscillators, being adjusted on either side of true neutralization, in order to control the amount of feedback and to reduce the effect of tube and plate circuit variations upon the frequency-controlling grid circuit.

Two band operation in oscillators using parallel rods can be arranged conveniently by shorting the open end of the grid control line with a second shorting bar, and readjusting the plate circuit. The resulting half wavelength grid line is loaded by the tube input

capacity, making it desirable to slide the grid taps down farther, and requiring a very much shortened line. For instance, a quarter wavelength grid line on 112 megacycles may be 19 or more inches long, whereas a loaded half wavelength line on 224 megacycles may turn out to be only 9½ inches, making it necessary to slide the upper or second shorting bar down from the former open end of the line.

As in the case of receivers, good antennas are helpful, and low angle power is most useful. Less trouble is reported with the proper adjustment of antennas for transmitting than for receiving, however, probably because there is power available with which to work.

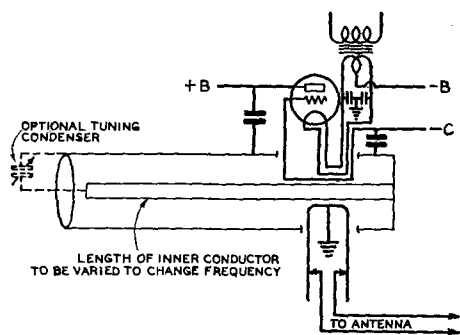

Figure 11.
COAXIAL PIPE OSCILLATOR USING
SINGLE TANK CIRCUIT.

The frequency can be varied either by the optional tuning condenser shown or by varying the length of the inner conductor of the concentric line.

Amplifier Hints

The driving power required by an amplifier tube can be high if there are leads of any appreciable length from the grid or plate to any tuning condenser other than one used as a shorting bar on a pair of rods, or if the condenser has a long inductive path through its frame. The returns from these circuits to the cathode are important, especially in single-ended stages. Lead inductance can be reduced by using copper ribbon or tubing for connections, instead of smaller wire.

Frequency doublers have been used to 224 megacycles. Push-pull triplers, especially when some regeneration is permitted by using a dual frequency grid circuit or a tuned cathode circuit, are highly satisfactory even

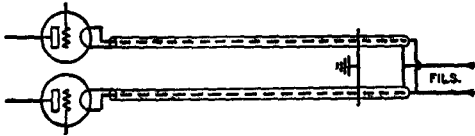

Figure 12.

Arrangement for using shorted $\frac{1}{2}$ -wave line in filament circuit to put both filaments at exact ground potential.

above 224 Mc. when suitable tubes are used.

Oscillation difficulties often arise in beam tetrodes due to the resonant frequency of the screen circuit. Where this occurs and cannot be corrected by changing the screen by-pass condenser or its position, a small choke can be inserted in the screen lead before the by-pass condenser.

Both in receivers and transmitters, regeneration or oscillation often results from the use of cathode bias, not adequately by-passed for u.h.f. Ordinary by-pass condensers have considerable inductance in them which combined with their capacity may place a sizable reactance in common with the grid and plate returns. Small silvered mica condensers have sometimes proved better than units of average size and higher capacity. Special u.h.f. sockets with built in by-pass condensers can be used to advantage above 200 Mc.

Centimeter Waves and Microwaves

With the advent of specially built tubes, it is no longer difficult to obtain appreciable power at $\frac{3}{4}$ meter (75 centimeters, 400 megacycles) and beyond. The W.E. 316-A will deliver five watts or more at 400 Mc., while the RCA 1628 as an amplifier is rated at 50 watts input at 500 Mc. and 43 watts at 675 Mc., the output depending on the circuit and efficiency.

A relatively new development is the velocity-modulated Klystron, with which an output of a hundred watts can be obtained at 750 Mc. in an oscillator-amplifier set-up. The tube is like a cathode ray tube, with the

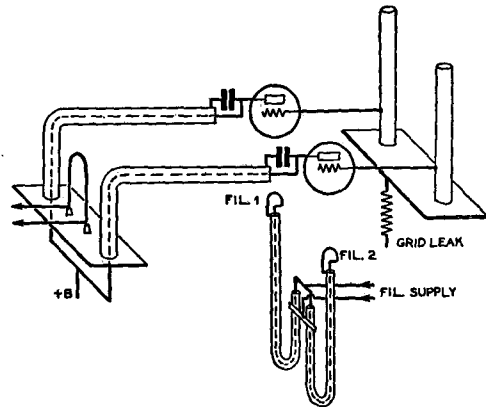

Figure 13.

Practical physical layout for push-pull oscillator using resonant lines in filament, grid, and plate circuits.

stream of electrons passing a hole in a surrounding copper can.

Due to the "cavity resonance" of the chamber, which is essentially a self-enclosed quarter-wave transmission line, power is developed within it which can be delivered to the load by means of a half-turn coupling loop. These tubes are available under the description "RCA-825 Inductive Output Amplifier." They are designed for use at frequencies of 300 Mc. and above, where they are capable of power outputs of 35 watts. A relatively high degree of efficiency is attainable with this type of amplifier stage, 60% efficiency being typical at 500 Mc. Power is placed on the "collector," or plate, which is rated at a maximum of 2000 v.d.c. and 50 ma. The higher voltages required on the other elements are attainable at low-cost, as in cathode-ray tube circuits, because of the insignificant current required. The rated collector dissipation of the tube is fifty watts.

Further U.H.F. Data. For information on transmitters, receivers and antennas for use on the ultra-high frequencies, turn to Chapters 18, 19 and 21.

CHAPTER EIGHTEEN

U. H. F. Receivers and Transceivers

56 MC. CONVERTER

For receiving stabilized amplitude modulated signals on 56 Mc., an ordinary communications receiver can be used in conjunction with a suitable converter. The converter illustrated in figures 1 and 2 will be found highly sensitive and ideal for the job.

A high gain mixer using either an 1852 or 1231 receives injection voltage from a 6C5, 6J5, or 7A4 "hot cathode" oscillator.

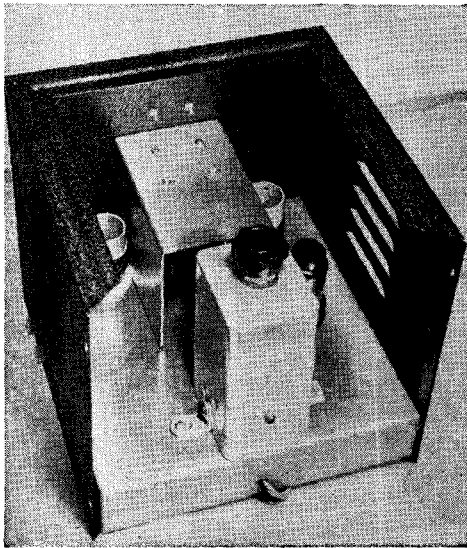

Figure 1.
INSIDE THE 1852 U.H.F. CONVERTER
CABINET

The two-gang tuning condenser is under the U-shaped shield between the two coils. The can in the foreground houses the output coil, L_4 , and its trimmer, C_6 . Directly behind this can and hidden from view is the 1852; the 6C5 may be seen to the right.

Construction

The photograph illustrates the layout. A small stock cabinet and the chassis designed for it form the basis for the unit. Mounted in the center of the panel is a small $25 \mu\text{fd.}$ per section dual-stator variable. The section nearer the panel, tuning the mixer input, has only one remaining stator plate; the rear portion, for the oscillator, has all but two stator plates removed. This condenser is mounted with the four tapped holes in the frame pointing upward. These holes are then used to support a shield which in addition to covering the condenser also acts as a baffle between the two coils.

Directly back of the tuning gang is the 1852 mixer; to the left is the oscillator coil, and to the right, the mixer coil. The can behind the 1852 contains a tuned output coil and link coupling to the receiver used as an i.f. channel. Below the tuning gang is a $15\text{-}\mu\text{fd.}$ trimmer on the mixer to eliminate tracking problems on separate bands.

All oscillator leads should be made rigid to avoid shock detuning of the circuit. The ground leads are all brought to one point, which is even more advisable in the mixer circuit where an extra fraction of an inch in the cathode lead, common to both the grid and plate returns, is undesirable in that it affects the gain.

The converter is designed to work into a receiver tuned to a spot between 3000 and 3500 kc. The output coil L_4 is simply a midget b.c.l. antenna coil of the type having a low impedance primary. The coil is tuned by the mica trimmer C_6 and used backwards, the "primary" acting in this case as the secondary.

In some cases operation will be improved by connecting a $.0005 \mu\text{fd.}$ midget mica condenser directly from the plate of the 6C5 to ground.

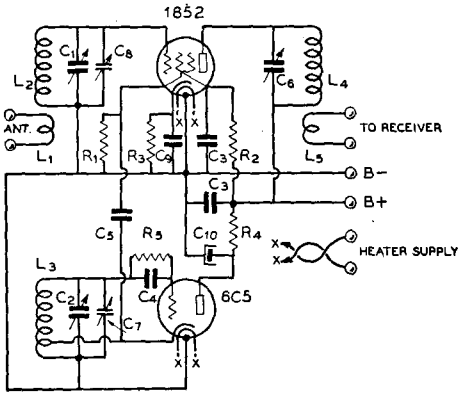

Figure 2.
GENERAL WIRING DIAGRAM OF THE 1852 CONVERTER.

- | | |
|--|---|
| C_1, C_2 — Dual 25- μ fd. midget, altered as described in text | R_1 —5000 ohms, 1 watt |
| C_3 —.01 mica | R_5 —50,000 ohms, 1/2 watt |
| C_4, C_5 —.00005- μ fd. mica | L_1 —3 turns at cold end of L_2 |
| C_6 —100- μ fd. mica trimmer | L_2 —3 turns on 1" form spaced dia. of wire |
| C_7 —25- μ fd. air trimmer | L_3 —3 3/4 turns on 1" form spaced dia. of wire. Cathode tapped 3/4 turn from cold end. |
| C_8 —17.5- μ fd. midget | L_4, L_5 — Solenoid type midget b.c.l. antenna coil, half of turns removed from both windings |
| C_9 —.01- μ fd. mica | |
| C_{10} —8- μ fd. 450-volt electrolytic | |
| R_1 —25,000 ohms, 1/2 watt | |
| R_2 —40,000 ohms, 1 watt | |
| R_3 —1500 ohms, 1 watt | |

Adjustment

The first step in lining up the converter is to adjust the output circuit to resonance with the receiver used as an i.f. amplifier. This is easily done inasmuch as the receiver noise, due both to shot effect in the mixer tube and signal or background racket at the i.f., increases when the circuit is brought in tune. The oscillator can be tuned around to locate a signal, but an easier way to set the oscillator is to listen for it in an all-wave receiver and set it at 28 Mc. plus the i.f.

When this adjustment has been made, there remains only to line up the mixer input circuit on outside noise or on a signal, using the trimmer on the panel (which also acts as a gain control). Ordinarily it will be necessary to obtain proper antenna coupling, inasmuch as high antenna pick-up and transfer to the mixer input will be important in determining weak-signal sensitivity and signal-to-noise ratio.

Voltage Regulation. If plate voltage fluctuations are sufficient to cause an objection-

able shift in the oscillator frequency, as might be the case with an a.c. power pack running from a line to which several large intermittent loads are connected, the oscillator plate voltage can be stabilized simply by hooking a VR-150-30 type voltage regulator tube between the low side of R_4 and ground. The VR tube should be shunted by a .05- μ fd. tubular condenser. The plate supply should have at least 225 volts for the VR tube to function properly.

U.H.F. SUPERHET WITH R/C COUPLED I.F.

A simple 2 1/2- and 5-meter resistance-coupled superheterodyne is shown in figures 3, 4, and 5. The receiver utilizes a 1232 or 1853 autodyne converter (oscillator and mixer), two 6SK7 resistance coupled i.f. stages, a 6C5 second detector, and a 6H6 noise limiter to minimize auto ignition interference.

The values of resistors and condensers in the i.f. amplifier are such that only intermediate frequencies are passed; the coupling condensers are too small to pass audio frequencies. The i.f. amplifier has a broad peak around 50,000 cycles, the selectivity being increased slightly by the resonant coil L_2 , which is simply an 85-mh. radio-frequency choke. The resonant circuit formed by C_5 and L_2 would result in an order of selectivity too great to receive the less stable of the modulated oscillators heard on 2 1/2 meters; hence the selectivity is broadened by the insertion of R_4 . The selectivity can be altered by changing the

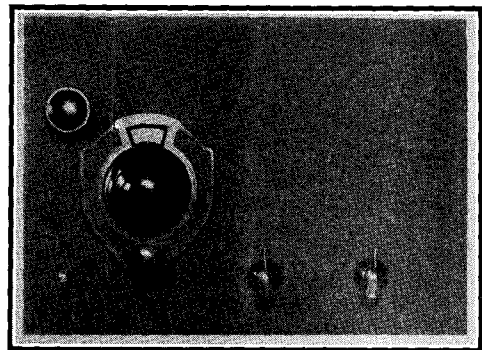

Figure 3.
SIMPLEST INEXPENSIVE 2 1/2 AND 5 METER SUPERHET.

This receiver uses an autodyne converter and resistance coupled i.f. amplifier. It is more selective than a superregenerative receiver and does not have the background hiss common to superregenerative receivers.

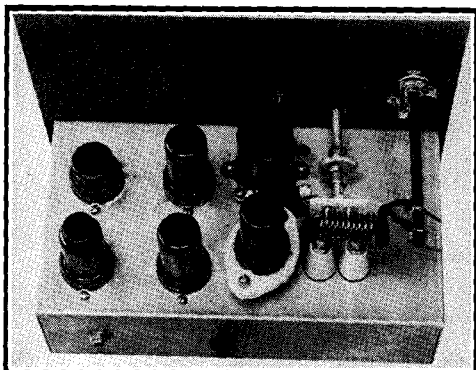

Figure 4.
BACK VIEW OF THE R/C COUPLED
SUPERHET.

Five metal tubes are used. The 85-mh. radio frequency choke L_2 may be seen directly in front of the 1853. Note the method of obtaining variable antenna coupling.

value of R_4 ; lowering the resistance will sharpen the circuit and vice versa. Selectivity will be greatest with the resistor left out of the circuit.

The receiver also works fairly well on frequency modulated signals, so long as the deviation ratio does not exceed about 25 kc. However, because there is no limiter in the r.f. section, the signal-noise ratio will be no better than with amplitude modulation of the same carrier.

The 1853 oscillates weakly about 50 kc. to one side of the signal being received, thus acting both as first detector and h.f. oscillator. If there is too much regeneration or the antenna coupling is too loose, the tube will have a tendency to go into superregeneration, which prevents the rest of the receiver from functioning properly. Superregeneration is identified by a howl or loud hiss in the phones. Because the i.f. is such a low frequency and the first detector tank circuit shows no discrimination between signals only twice the i.f. (100 kc.) apart, all amplitude modulated signals are heard at two closely spaced spots on the dial. The points are so close that signals appear to come in at one point on the dial but with a "double hump." Another way of explaining it is to say that the i.f. is so low and the first detector frequency so high that the customary superheterodyne "image" is every bit as loud as the main signal, but so close to it in frequency as to appear as part of the main signal.

In spite of the "double hump" the receiver is much more selective than a superregenera-

tive receiver, is very sensitive (especially when used with a resonant antenna), and costs less to build than a regular superheterodyne. It is the only practical form of amateur superheterodyne for $2\frac{1}{2}$ -meter operation. There is only one dial to tune, and as the tuning condenser has but one section there are no circuits to align.

The 500-ohm resistor R_{17} usually is necessary in order to reduce the very strong regeneration resulting from the use of a cathode r.f. choke. Without this resistor the stage often has a tendency to superregenerate even when heavy antenna coupling is used. The receiver should be tried both with and without this resistor on both $2\frac{1}{2}$ and 5 meters to ascertain whether its incorporation is advisable.

Variable antenna coupling is necessary for maximum response to weak signals, but the coupling need seldom be touched after it is once adjusted, except when changing antennas. Regeneration in the 1853 is controlled by the resistor R_2 , and the antenna coupling should be adjusted so that the 1853 goes into weak oscillation with R_2 advanced just a little more than half way. A piece of quarter-inch bakelite rod turning in a phone jack as a bearing makes the antenna coupling adjustable from the front panel, as is illustrated in figure 4.

The 1853 socket is mounted above the chassis on $\frac{3}{4}$ inch collars. The socket must be of the ceramic or polystyrene type, though the rest of the sockets may be of the inexpensive fiber wafer variety. All r.f. grounds in the 1853 stage are made directly from the tube prongs to a lug placed under one of the screws holding the socket. This lug (the one closest the front panel) connects with a short piece of no. 14 copper wire to the rotor of the midget tuning condenser, the latter being mounted back from the panel as illustrated in figure 4 in order to obtain the shortest possible leads. The condenser and coil jacks (jack type standoff insulators) are mounted so that the terminals on the tuning condenser can be soldered directly to the coil jacks without the need for connecting wires. All r.f. leads must be kept extremely short for good $2\frac{1}{2}$ -meter performance.

Both the $2\frac{1}{2}$ - and 5-meter coils are wound of no. 14 enamelled copper wire and are self-supporting. The ends are fastened to the small type banana plugs, which fit into the coil jacks. The 5-meter coil consists of 10 turns $\frac{1}{2}$ inch in diameter and spaced to $1\frac{1}{4}$ inches. The $2\frac{1}{2}$ -meter coil consists of 3 turns $\frac{3}{8}$ inch in diameter spaced to 1 inch. The antenna coil consists of about 2 turns of insulated hook-up wire fastened to the bakelite shaft al-

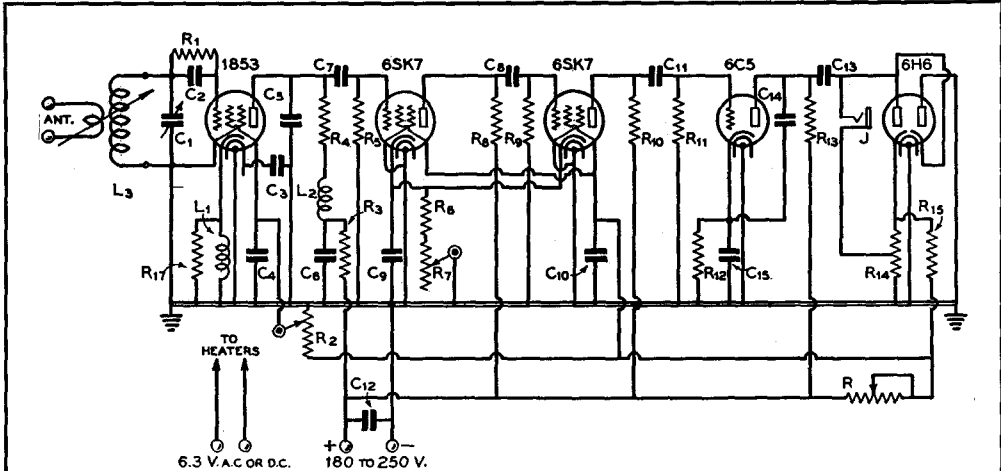

Figure 5.

WIRING DIAGRAM OF THE R/C SUPERHET.

- | | | | |
|---|--|--|--|
| <p>C₁—10-μfd. 2 or 3 plate ultra midget u.h.f. condenser
 C₂—50-μfd. midget mica
 C₃—0.01-μfd. midget mica
 C₄—0.005-μfd. midget mica
 C₅—0.001-μfd. midget mica
 C₆—0.1-μfd. tubular, 600 v.
 C₇—50-μfd. midget mica
 C₈—50-μfd. midget mica</p> | <p>C₉, C₁₀—1-μfd. tubular, 200 v.
 C₁₁—50-μfd. midget mica
 C₁₂—1-μfd. paper, 400 v.
 C₁₃—0.25-μfd. tubular, 400 v.
 C₁₄—0.005-μfd. midget mica
 C₁₅—0.5-μfd. tubular, 200 v.
 L₁—5 meter r.f. choke (solenoid type)
 L₂—85-mh. r.f. choke
 L₃—5-m. or 2$\frac{1}{2}$-m. plug-in coil. See text</p> | <p>R—10,000 ohms for 250 v. supply; 5000 ohms for 180 v. supply. (10 watts with slider)
 R₁—100,000 ohms, 1/4 watt
 R₂—50,000 ohm pot. (det. regeneration)
 R₃—10,000 ohms, 1/2 watt
 R₄—500 ohms, 1/4 watt
 R₅—0.5 meg. 1/4 watt
 R₆—200 ohms, 1/2 watt
 R₇—50,000 ohm pot. (gain control)</p> | <p>R₈—100,000 ohms, 1/2 watt
 R₉—0.5 meg., 1/4 watt
 R₁₀—100,000 ohms, 1/2 watt
 R₁₁—0.5 meg., 1/2 watt
 R₁₂—25,000 ohms, 1/2 watt
 R₁₃—50,000 ohms, 1/2 watt
 R₁₄—100 ohms, center tapped
 R₁₅—2000 ohms, 5 watts
 R₁₇—500 ohms, 1/4 watt (see text)</p> |
|---|--|--|--|

ready mentioned, as illustrated in figure 4. For mobile work the 5-meter coil should be stiffened with polystyrene coil dope to prevent vibration of the turns.

The i.f. amplifier can be made to oscillate by advancing the gain control R₇ full on when the receiver is run at full plate voltage. If this is found objectionable the resistor R₆ should be increased to 1000 ohms. The lower value of resistor permits greater sensitivity when only a low voltage plate supply is available, as might be the case when the receiver is used with B batteries for portable work.

The receiver will work quite well on about 90 volts, though operation is improved by increasing the plate voltage to 180. If the receiver refuses to oscillate satisfactorily on 2 $\frac{1}{2}$ meters with low plate voltage, resistor R₁₇ should be temporarily disconnected.

Disconnecting the resistor R will reduce the battery drain considerably, but the noise silencer will no longer function. If a regular a.c. power pack furnishes power, the receiver

should be used exactly as shown in the circuit diagram.

If loudspeaker operation is desired, a conventional 6V6 or 6F6 pentode output stage can be added, the 6C5 stage having sufficient output to drive the 6V6 or 6F6 to full loudspeaker volume.

112 MC. SUPERHET FOR EITHER AMPLITUDE OR FREQUENCY MODULATION

The 112 Mc. superheterodyne illustrated in figures 7-10 provides excellent performance on either amplitude modulated (AM) or frequency modulated (FM) signals. The i.f. channel is broad enough that amplitude modulated oscillators can be received satisfactorily if the oscillator is reasonably stable.

High sensitivity is provided by the use of an acorn pentode and a coaxial pipe tank circuit

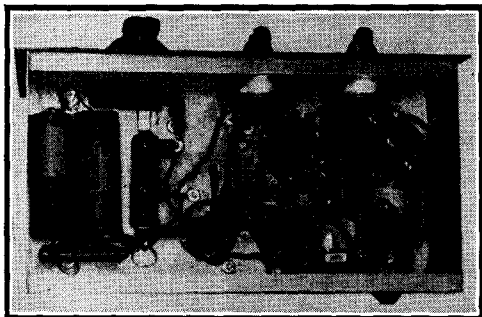

Figure 6.
UNDER-CHASSIS VIEW OF R/C SUPERHET.
Under the chassis are placed all resistors except the grid leak, and all paper by-pass condensers.

in the mixer, in conjunction with control grid injection of the oscillator voltage.

For reception of amplitude modulated signals, the limiter is "opened up" by means of switch S_2 (which is operated by turning R_{17} full off) and the 6H6 discriminator is changed to a diode demodulator by means of switch S_2 .

Construction

The chassis, which is surmounted by an 8" x 17" panel, measures 7 by 15 by 3 inches.

The 956 is located near the left rear corner of the chassis, with its concentric grid tank running along the rear of the chassis, as is apparent from the photographs. The concentric tank is held to the chassis by two copper straps, one near each end. The mixer grid condenser is placed between the 956 and the left edge of the chassis, making it convenient to secure short leads to both the mixer and the inner conductor of the tank circuit.

To help in obtaining short leads, the oscillator socket has been mounted with its base above the chassis, making it necessary that the 6J5GT be located under the chassis. The oscillator grid coil is supported from the tuning condenser on one end and the no. 1 socket terminal on the other. The plate by-pass C_{24} is located right at the socket and connected in the shortest possible manner between the plate and no. 1 terminal. A dial having a built-in planetary reduction unit is used on the oscillator to allow accurate tuning.

To aid in isolating the oscillator and mixer from each other so that the injection may be controlled by pushing the lead from the mixer grid in and out of the outside conductor of the mixer tank circuit, a 3 by 4 inch copper shield is placed between the two stages. The shielding is supported by small angle brackets.

The first i.f. transformer, T_1 , is located di-

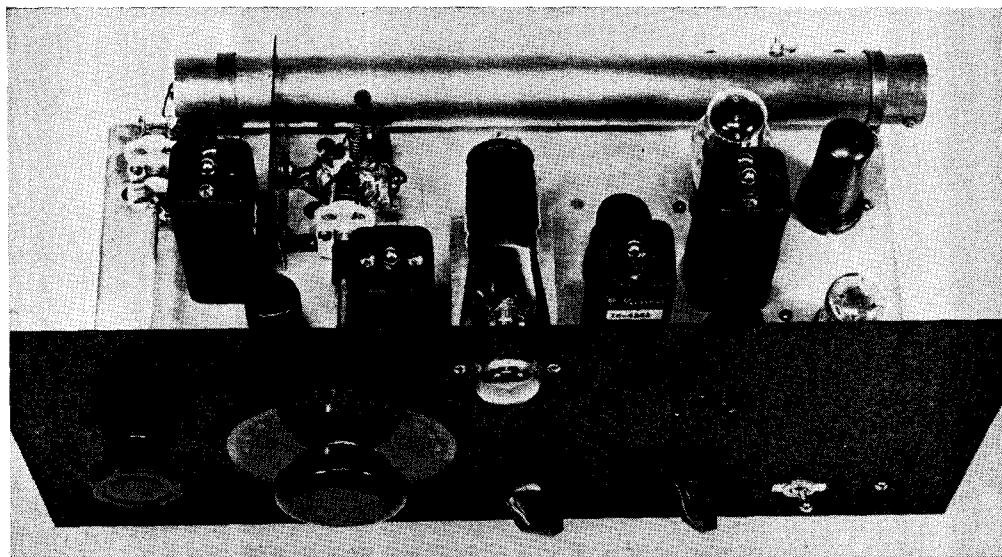

Figure 7.
LOOKING DOWN FROM THE FRONT OF THE 112-MC. F.M.-A.M. RECEIVER.
The adjustable coupling lead from the oscillator grid through the concentric mixer grid tank is visible in this photograph. The controls are, from left to right, mixer tuning, oscillator tuning, limiter "threshold" and limiter cut out, audio gain, and f.m.-a.m. switch.

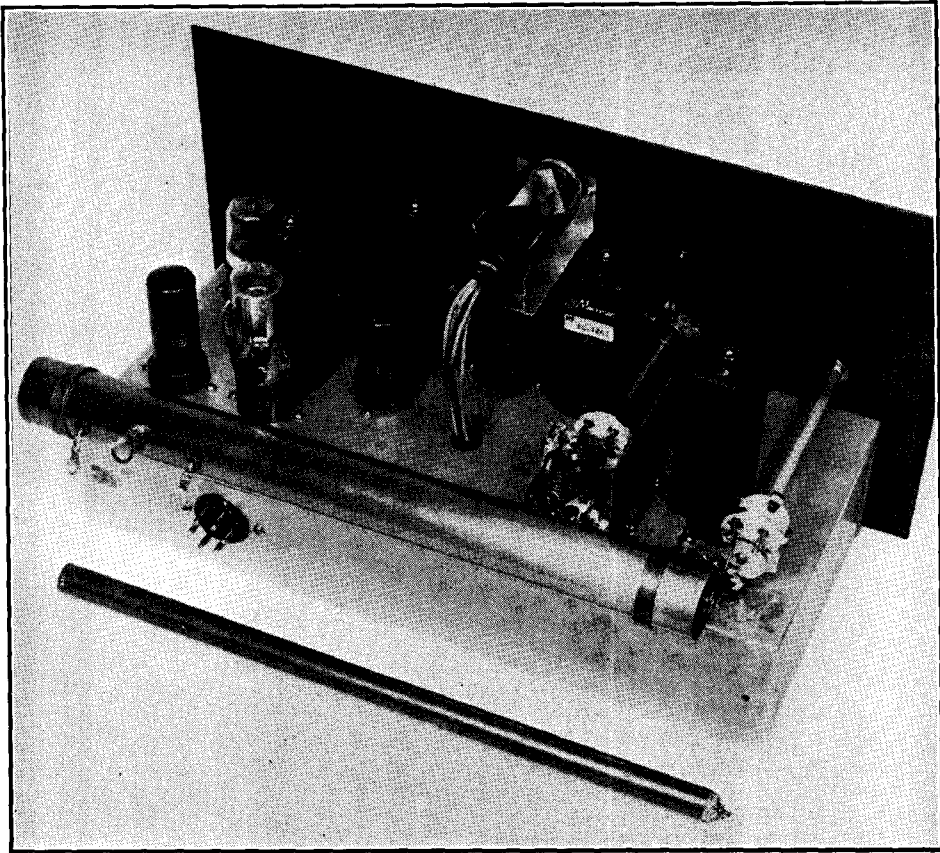

Figure 8.
SHOWING CONSTRUCTION DETAILS OF THE 112-MC. F.M.-A.M. RECEIVER.
 The outer conductor of the concentric pipe tank is held firmly and grounded electrically to the chassis by means of a narrow copper strap at each end of the tank. The shield partition between the oscillator and mixer circuits is necessary for good stability. The smaller diameter tank shown in the foreground works almost as well as the large one, and may be substituted if desired. The inner conductor of the smaller tank is held in position at the unshorted end by means of a polystyrene spacer.

rectly in front of the mixer, with the first 1852 between this transformer and the panel. The second i.f. stage with its associated transformers, T_2 and T_3 , runs along the front of the chassis from left to right. Behind T_3 is the 6SJ7 limiter, which feeds through the discriminator transformer at its right to the 6H6 discriminator between the transformer and the panel. The audio follows along the right edge of the chassis, while the VR-150 regulator is located behind T_4 .

The only wiring precaution that need be observed is keeping the grid and plate leads short. This holds for the i.f. section as well as for the high frequency circuit. No regeneration trouble in the i.f. section should be

experienced if the grid and plate leads run directly from small holes below the i.f. transformer to their proper terminating point of the sockets.

The mica by-pass and coupling condensers in the mixer and oscillator sections should be of the smallest physical size available, since a physically small .00005- μ fd. condenser will often prove to be a better by-pass or coupling device at 112 Mc. than a .002- μ fd. or larger mica condenser having proportionately larger dimensions.

The Coaxial Tank. The mixer tank consists of a 14 inch length of $1\frac{3}{8}$ -inch copper pipe as the outer conductor and a $\frac{3}{16}$ -inch copper tubing inner conductor. These con-

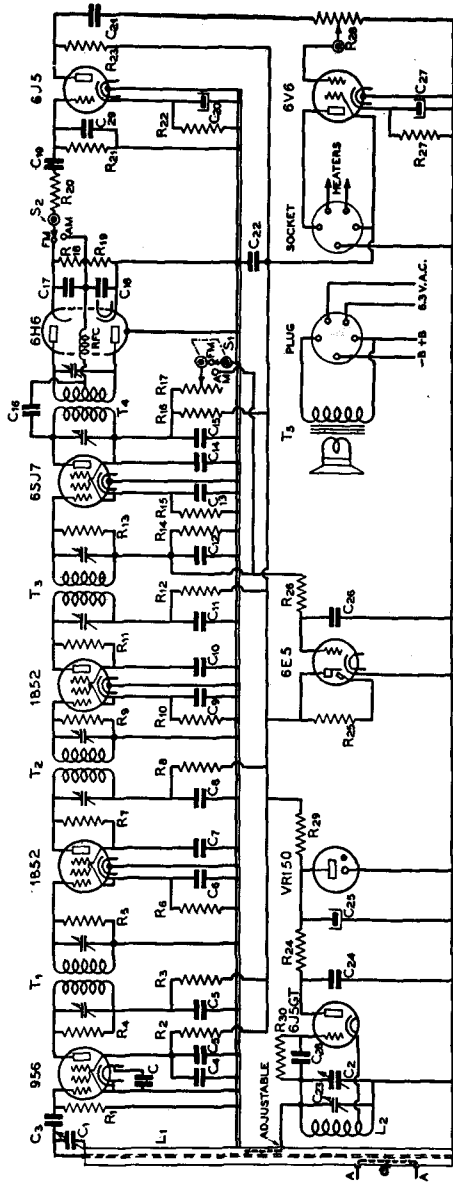

Figure 9.
WIRING DIAGRAM
OF THE
F.M.-A.M. RECEIVER.

VALUES OF COMPONENTS

- C₃₀—0.001- μ fd. mica
- C₁—7- μ fd. midget with one stator plate removed
- C₂—15- μ fd. midget variable
- C₃—0.0001- μ fd. mica
- C₄, C₅, C₆, C₇, C₈, C₉, C₁₀, C₁₁—0.01- μ fd. 600-volt tubular
- C₁₂—0.001- μ fd. mica
- C₁₃, C₁₄, C₁₅—0.1- μ fd. 600-volt tubular
- C₁₆—0.0005- μ fd. mica
- C₁₇, C₁₈—0.001- μ fd. mica
- C₁₉—0.01- μ fd. 600-volt tubular
- C₂₀—10- μ fd. 25-volt electrolytic
- C₂₁—0.0005- μ fd. mica
- C₂₂—0.0005- μ fd. mica
- C₂₃—0.005- μ fd. mica
- C₂₄—0.01- μ fd. 600-volt tubular
- C₂₅—10- μ fd. 25-volt electrolytic
- C₂₆—0.0005- μ fd. mica
- C₂₇—0.005- μ fd. mica
- C₂₈—0.01- μ fd. 600-volt tubular
- R₁—5 megohms, 1/2 watt
- R₂—100,000 ohms, 1 watt
- R₃—2000 ohms, 1/2 watt
- R₄—50,000 ohms, 1/2 watt
- R₅—150 ohms, 1/2 watt
- R₆—30,000 ohms, 1 watt
- R₇—2000 ohms, 1/2 watt
- R₈—50,000 ohms, 1/2 watt
- R₉—150 ohms, 1/2 watt
- R₁₀—75,000 ohms, 1 watt
- R₁₁—10,000-ohm wire-wound potentiometer
- R₁₂—100,000 ohms, 1/2 watt
- R₁₃—50,000 ohms, 1/2 watt
- R₁₄—500 ohms, 10 watts
- R₁₅—500,000-ohm potentiometer
- R₁₆—3000 ohms, 10 watts
- R₁₇—100,000 ohms, 1/2 watt
- R₁₈—100,000 ohms, 1/2 watt
- R₁₉—5000 ohms, 1/2 watt
- R₂₀—500,000 ohms, 1/2 watt
- R₂₁—2000 ohms, 1/2 watt
- R₂₂—30,000 ohms, 1 watt
- R₂₃—2000 ohms, 1/2 watt
- R₂₄—50,000 ohms, 1 watt
- R₂₅—250,000 ohms, 1/2 watt
- R₂₆—100 ohms, 1/2 watt
- R₂₇—1 megohm, 1/2 watt
- R₂₈—500 ohms, 10 watts
- R₂₉—5000 ohms, 10 watts
- R₃₀—100,000 ohms, 1/2 watt
- R₃₁—3000 ohms, 1 watt
- R₃₂—1 megohm, 1/2 watt
- R₃₃—1 megohm, 1/2 watt
- R₃₄—3000 ohms, 1 watt
- R₃₅—1 megohm, 1/2 watt
- R₃₆—1 megohm, 1/2 watt
- R₃₇—1 megohm, 1/2 watt
- R₃₈—1 megohm, 1/2 watt
- R₃₉—1 megohm, 1/2 watt
- R₄₀—1 megohm, 1/2 watt
- R₄₁—1 megohm, 1/2 watt
- R₄₂—1 megohm, 1/2 watt
- R₄₃—1 megohm, 1/2 watt
- R₄₄—1 megohm, 1/2 watt
- R₄₅—1 megohm, 1/2 watt
- R₄₆—1 megohm, 1/2 watt
- R₄₇—1 megohm, 1/2 watt
- R₄₈—1 megohm, 1/2 watt
- R₄₉—1 megohm, 1/2 watt
- R₅₀—1 megohm, 1/2 watt
- R₅₁—1 megohm, 1/2 watt
- R₅₂—1 megohm, 1/2 watt
- R₅₃—1 megohm, 1/2 watt
- R₅₄—1 megohm, 1/2 watt
- R₅₅—1 megohm, 1/2 watt
- R₅₆—1 megohm, 1/2 watt
- R₅₇—1 megohm, 1/2 watt
- R₅₈—1 megohm, 1/2 watt
- R₅₉—1 megohm, 1/2 watt
- R₆₀—1 megohm, 1/2 watt
- R₆₁—1 megohm, 1/2 watt
- R₆₂—1 megohm, 1/2 watt
- R₆₃—1 megohm, 1/2 watt
- R₆₄—1 megohm, 1/2 watt
- R₆₅—1 megohm, 1/2 watt
- R₆₆—1 megohm, 1/2 watt
- R₆₇—1 megohm, 1/2 watt
- R₆₈—1 megohm, 1/2 watt
- R₆₉—1 megohm, 1/2 watt
- R₇₀—1 megohm, 1/2 watt
- R₇₁—1 megohm, 1/2 watt
- R₇₂—1 megohm, 1/2 watt
- R₇₃—1 megohm, 1/2 watt
- R₇₄—1 megohm, 1/2 watt
- R₇₅—1 megohm, 1/2 watt
- R₇₆—1 megohm, 1/2 watt
- R₇₇—1 megohm, 1/2 watt
- R₇₈—1 megohm, 1/2 watt
- R₇₉—1 megohm, 1/2 watt
- R₈₀—1 megohm, 1/2 watt
- R₈₁—1 megohm, 1/2 watt
- R₈₂—1 megohm, 1/2 watt
- R₈₃—1 megohm, 1/2 watt
- R₈₄—1 megohm, 1/2 watt
- R₈₅—1 megohm, 1/2 watt
- R₈₆—1 megohm, 1/2 watt
- R₈₇—1 megohm, 1/2 watt
- R₈₈—1 megohm, 1/2 watt
- R₈₉—1 megohm, 1/2 watt
- R₉₀—1 megohm, 1/2 watt
- R₉₁—1 megohm, 1/2 watt
- R₉₂—1 megohm, 1/2 watt
- R₉₃—1 megohm, 1/2 watt
- R₉₄—1 megohm, 1/2 watt
- R₉₅—1 megohm, 1/2 watt
- R₉₆—1 megohm, 1/2 watt
- R₉₇—1 megohm, 1/2 watt
- R₉₈—1 megohm, 1/2 watt
- R₉₉—1 megohm, 1/2 watt
- R₁₀₀—1 megohm, 1/2 watt

T₆—Pentode-plate-to-voice coil transformer (on speaker)

S₁—S.p.d.t. switch (on R₃₁)

S₂—S.p.d.t. toggle switch

RFC—2 1/2 mhy

L₁—14" copper conductor 1 3/8" o.d., inner conductor 3/16" o.d.

L₂—5 turns of No. 16 bare copper, 1/4" inside diameter and wound to a length of 1 1/2". Cathode tap 1 1/2 turns from ground end.

ductors give a radius ratio of approximately 7-1, which seems to be a good compromise between impedance, Q , and overall tank size.

No actual "shorting disc" is used with the line shown in the receiver. The inner conductor is merely flattened at the "closed" end of the tank and two short right-angle bends made to allow it to be held to the outer conductor with a screw. This method is perfectly permissible where extremely high Q in the line is not necessary.

The antenna coupling "loop" is a piece of no. 10 wire covered with "spaghetti" where it is inside the tank, and supported within the tank by being run through tight fitting grommets in the outer conductor. A lead soldered to the center of the loop inside the tank is brought out and provided with a lug to enable the center of the loop to be grounded when a balanced, two-wire feeder is used. The end of the loop nearest the shorted end of the tank is grounded when a single-feeder type antenna is used. The loop is $2\frac{1}{2}$ inches wide, but experiment will probably be necessary to obtain optimum coupling with lines of different impedance than the 400-ohm feeder used with the original receiver. Cou-

pling adjustments are made by pushing the loop toward or away from the inner conductor.

If desired, a smaller diameter tank may be used, so long as the outer conductor is at least $\frac{1}{2}$ inch in diameter and the conductor ratio is kept between 6 and 10. Unless the ratio is exactly 7, the length of the tank will have to be altered slightly. The performance will be practically as good as with the $1\frac{3}{8}$ inch diameter tank.

The Discriminator Transformer. As received from the manufacturer the transformer, T_4 , specified in the diagram has no center tap on its secondary and lacks sufficient coupling to serve as a discriminator transformer. Consequently the transformer must be altered as follows: After removing the transformer from its shield can, the lower winding, which is to become the secondary, is completely unwound from the dowel. If the unwinding is done carefully a narrow ridge of the compound with which the windings are impregnated will be left on each side of the space the winding occupied. These ridges will form a sort of "slot" in which to rewind the wire which has been removed. It will be found

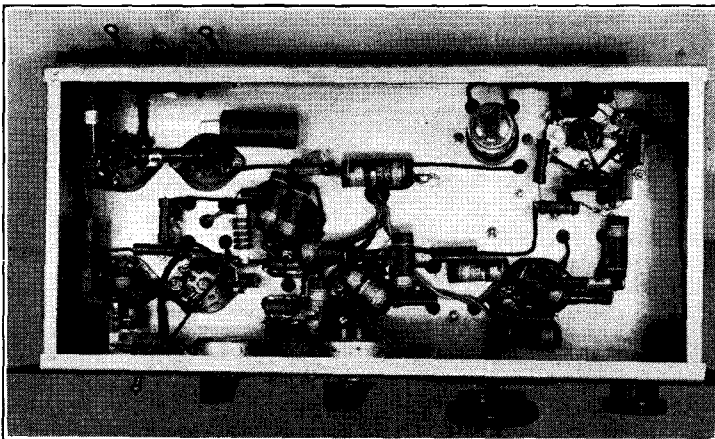

Figure 10.

UNDER-CHASSIS VIEW.

The 956 mixer and the 6J5GT oscillator may be seen under the chassis of the receiver. The two lugs protruding from the concentric tank at the upper left of the photograph are for antenna connections.

that about 65 turns of wire were on the winding but it will be impossible to get more than 55 to 58 turns back in the slot by hand scramble-winding methods. In the receiver shown, a trial rewinding of the wire indicated that 56 turns could be replaced, necessitating that the center tap be brought out at the 28th turn.

After the secondary has been rewound on the dowel it should be thoroughly covered with Duco cement or a similar coil compound and allowed to dry for an hour or more. When the cement has dried thoroughly it will be found that a firm pressure against the winding will allow it to be slid along the dowel toward the primary to increase the coupling between the windings. The proper location for the secondary is a position where the distance between the adjacent edges of primary and secondary is about $\frac{1}{8}$ inch. Another coating of the coil dope will hold the winding in place, and the transformer may be reassembled in its shield can and installed in the receiver.

Adjustment

Aligning the I.F. Channel. There is no really simple way of accurately aligning the i.f. and discriminator in a f.m. receiver. The inclusion of a 6E5 "magic eye" tube operating from the voltage developed across the limiter bias does help considerably, however, aside from its intended use as an accurate tuning indicator for placing f.m. signals "on the nose." Probably the easiest method of aligning the receiver is first to couple loosely an ordinary tone-modulated signal generator to the plate of the mixer stage. With both switches set for "a.m." make a rough alignment for maximum audio output. This assumes that the i.f. transformers are somewhere in the vicinity of alignment so that some sort of signal may be forced through the i.f. channel to get a start on the trimming process. If no signal is heard at the output when the signal generator is applied at the mixer plate and tuned around over a narrow range around 3000 kc. it must be assumed that the i.f. transformers are considerably out of alignment and the usual procedure of first coupling the signal generator to the primary of the last i.f. transformer (T_4) and then working back toward the mixer stage must be followed.

After a rough setting of the trimmers has been made the alignment may take on a more exact nature. With the signal generator still applied to the primary of T_1 , but with switch S_1 changed to the "f.m." position by cutting

in all of R_{17} , each trimmer on the first three i.f. transformers should be adjusted for maximum voltage across R_{14} , as indicated by the closing of the "eye." Next, the setting of the trimmer across the secondary of T_4 should be tackled—and here is where the trimming becomes critical. Since the trimmer adjusting screw is "hot" for r.f., the tool used for this adjustment should be of the low-capacity type having a long composition or wood handle. The discriminator output switch, S_2 should be thrown to the "f.m." position and—assuming that the primary of T_4 has been set up somewhere near resonance in the previous rough alignment—tuning the secondary winding through resonance should give a very sharp and definite drop in the audio output, the audio-tone volume increasing on either side of resonance but dropping to a very low value or disappearing entirely at exact resonance. The signal from the signal generator should be kept at i.f. resonance, as indicated by the 6E5, during the alignment.

The last adjustment to be made should be that on the primary of T_4 . There are two ways of getting this circuit properly tuned. Probably the simplest method is to keep the signal generator tuned right in the "notch" of the secondary winding but increase the amount of signal applied to the i.f. channel until a small amount of audio comes through at this frequency and then tune the primary winding for maximum decrease or "dip" in the remaining audio.

The other method of trimming the primary involves rocking the signal generator back and forth across the resonant frequency previously obtained observing the strength of the peaks in audio output which are heard on each side of the "notch." When the primary is properly tuned these peaks will be symmetrically located, one on each side of the "notch" frequency, and of equal strength. If the i.f. loading resistors are of the values indicated under the diagram and the coupling between the primary and secondary of T_4 has been properly adjusted the peaks will be approximately 130 kc. apart.

Those who find it more convenient to use an unmodulated signal at the i.f. frequency and a vacuum-tube voltmeter or zero-center high-resistance voltmeter to align the i.f. and discriminator may do so by connecting the indicating instrument between the top of R_{18} and ground and, after aligning the i.f. transformers up to T_3 by the 6E5, adjusting T_4 so that zero voltage is obtained at the center of the i.f. band, and equal and oppositely-polarized voltages are obtained for equal and opposite shifts in signal-generator frequency

from center frequency. When a vacuum-tube voltmeter is used for this adjustment it will be necessary to place a battery in series with the instrument to bring it somewhere near half scale.

R.F. Alignment. There is little that need be said about tuning up the front end of the receiver, since the only problem is to find the band. The simplest way to do this is to hunt for a $2\frac{1}{2}$ -meter signal with the oscillator padding condenser, C_{23} , keeping the mixer grid aligned by following with C_1 . In the absence of signals the best procedure would be to set the oscillator tuning condenser at mid scale and adjust the padding condenser so that the oscillator is on a frequency 3000 kc. lower than the center of the band, or 111 Mc. The frequency should be measured by Lecher wires, the proper distance between points being very close to 53 inches. A detailed discussion of the use of Lecher wires is given in *Chapter Seventeen*. The glow in the VR-150 makes a fairly good resonance indicator for this purpose.

Lining up the mixer grid involves only tuning the mixer grid condenser and adjusting the antenna and oscillator coupling for maximum background or signal. The two coupling adjustments will be found to be somewhat interdependent and should be adjusted simultaneously. The mixer coupling is not extremely critical, however, and optimum results should be obtained over a wide range of injection voltage. Two inches of wire available for pushing through the grommet and into the mixer grid tank will provide sufficiently wide range of coupling from the oscillator. Too little coupling will result in a loss of sensitivity, while too much coupling will cause bad pulling of the oscillator by the mixer tuning. Fortunately maximum sensitivity is realized with quite a bit less coupling than is required to cause serious pulling.

56 Mc. Operation. This receiver makes an excellent 56 Mc. FM superheterodyne if a suitable coil is substituted for the coaxial mixer tank and a larger coil is substituted for the h.f. oscillator tank. No other changes need be made.

COMPACT 112 MC. SUPERREGENERATIVE RECEIVER

Illustrated in figures 11 and 12 is a compact and inexpensive 112 Mc. superregenerative receiver that will give excellent results on amplitude modulated signals either for mobile or fixed station use. It will also work

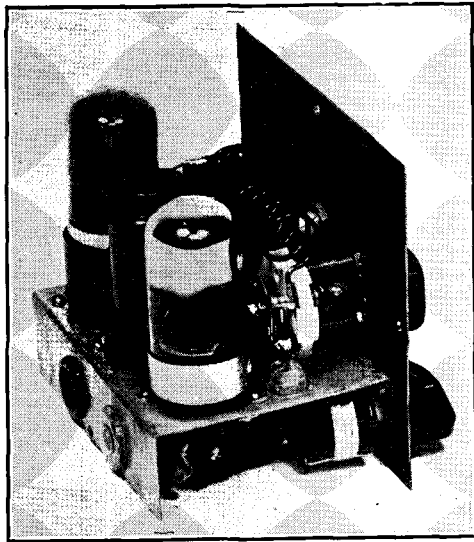

Figure 11.

INTERIOR VIEW OF THE RECEIVER.

The tuning condenser is supported from the front panel by means of two long bolts. The variable antenna coupling coil may be seen in back of the tank coil.

fairly well on frequency modulated signals, especially if the deviation (frequency swing) is comparatively large, but should be considered primarily as an amplitude modulation receiver.

Figure 11 illustrates the arrangement of components. If desired, the receiver need not be made quite so compact; this will simplify the wiring job somewhat.

It is important that a polystyrene or low loss (mica filled) bakelite loktal socket be used for the 7A4 for best results. Also, care should be taken to see that the rotor of the tuning condenser goes to the grid and the stator to the plate. A bakelite or hard rubber shaft extension must be used with the tuning condenser in order to prevent body capacity detuning effects. As an alternative, an insulated coupler may be used in conjunction with a short piece of metal shafting and a panel bearing. Both r.f. choke and grid leak should be connected with the shortest possible leads to the r.f. circuit.

The tank coil, which is soldered directly to the tuning condenser terminals, consists of 4 turns of no. 14 enameled wire, $\frac{1}{2}$ inch in diameter, spaced and trimmed as necessary to hit the band (as determined by Lecher wires).

One of the features of the receiver that results in vastly increased performance and

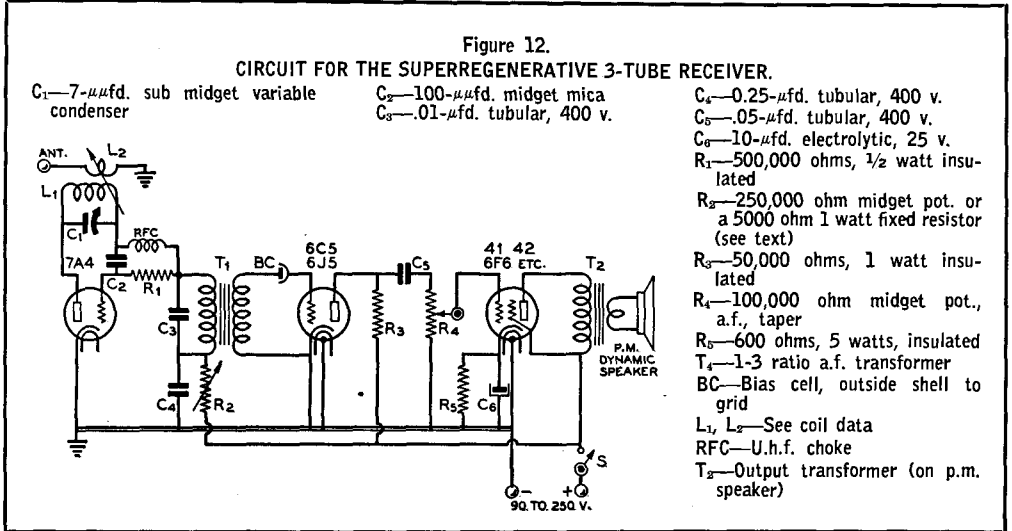

easier tuning is variable antenna coupling. This control has been found of greater importance than the regeneration control, as the latter may be set and left alone if variable antenna coupling is provided. In fact, the regeneration control may be omitted, if desired, in which case a 5000 ohm 1 watt resistor is substituted for R_2 .

The antenna coil consists of two turns of wire one inch in diameter, supported at the grid end of the tank coil. These are cemented with Amphenol 912 to a piece of Lucite or polystyrene 1/4-inch shafting, which is supported from the front panel by a pinch-fit shaft bearing. The bearing is placed slightly below the level of the bottom edge of the tank coil in order to permit sufficient variation in coupling. Flexible, insulated wire is used for

making connection to the two turn antenna coil.

When tuning the receiver, the tightest antenna coupling which will permit superregeneration should be used.

224 MC. SUPERREGENERATIVE RECEIVER

Except for the substitution of a linear tank circuit and an oscillator tube better adapted for use at the higher frequency, the 224 Mc. receiver of figures 13-16 is substantially the same from an electrical standpoint as the 112 Mc. superregenerative receiver of figures 11 and 12. The mechanical construction is somewhat different, however, as may be seen from figures 13, 14, and 16.

The receiver is constructed on a 5 1/2 by 11 inch chassis, 1 1/2 inches high, which supports a 5 by 9 inch front panel. The HY-615 oscillator tube is placed at one end of the chassis as illustrated in order to permit horizontal mounting of the linear tank circuit. This tank circuit consists of a length of no. 10 bare copper wire, bent back on itself so that the spacing of the two wires is approximately equal to the wire diameter. The grid wire is cut off shorter than the plate wire, in order to allow the insertion of the small grid condenser and grid leak. The overall length of the tank, from the center of the tube caps to the center of the bolt in the standoff insulator which supports the closed end of the "U" and acts as the plate voltage connection is 7 3/8 inches. This pillar type standoff insulator is 2 inches high.

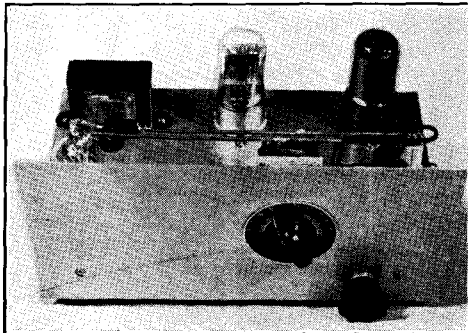

Figure 13.
224-MC. SUPERREGENERATIVE RECEIVER.

An HY-615 triode oscillator and linear tank circuit provide high sensitivity.

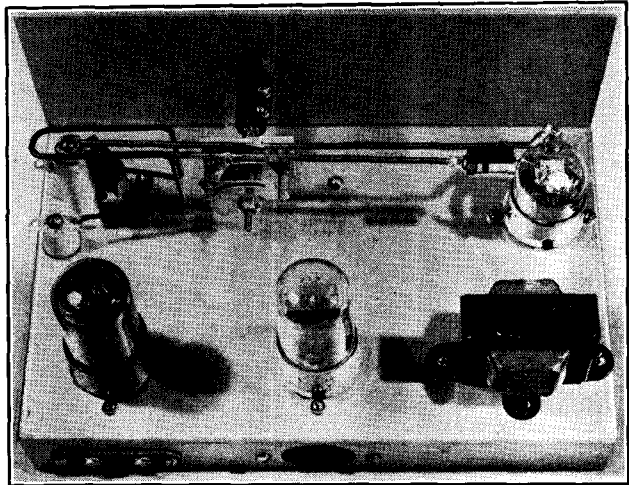

Figure 14.
ILLUSTRATING MECHANICAL CONSTRUCTION OF 224-MC. RECEIVER.

Note particularly the modified tuning condenser and the arrangement of the linear tank and the antenna coupling "hairpin loop."

Tuning is by means of an improvised split-stator type condenser, the rotor of which is left "floating." A Cardwell ZR-35-AS "Trim Air" is operated upon as follows. Disassemble the condenser so that all rotor and stator plates are removed. Discard all except four rotor and two stator plates. The four remaining rotor plates are not altered, but the two stator plates are trimmed with a pair of heavy shears so that each plate is supported by only one of the two stud bolts which originally supported all stator plates. The condenser then is assembled, making use of the original spacing washers, so that the two stator plates are 5/16 inch apart, one plate

being supported by one stud bolt and the other plate being supported by the other stud bolt. The four rotor plates are then attached, spaced so that each stator plate is enveloped by two rotor plates with the original spacing of .03 inch between adjacent rotor and stator plates. Inspection of figure 14 shows how the condenser looks when reassembled.

Connection from each stator to the parallel wires is made by means of two 7/8 inch solder lugs, the lugs being bent in towards each other as illustrated in order to permit connection at approximately the same point on each tank wire with respect to the closed end of the tank. The tuning condenser is mounted inverted by

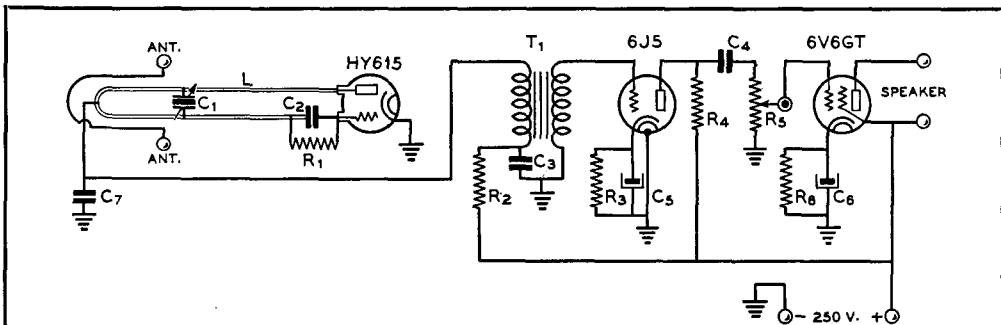

Figure 15.

SCHEMATIC DIAGRAM OF 224-MC. RECEIVER.

- | | | | |
|---|---|---------------------------------------|---|
| C ₁ —Modified midget condenser, see text | C ₅ , C ₆ —25- μ fd. 25 or 50 v. electrolytic | R ₂ —10,000 ohms, 1/2 watt | a. f. (audio gain) taper |
| C ₂ —50- μ fd. smallest fixed mica | C ₇ —.005- μ fd. midget mica | R ₃ —2000 ohms, 1/2 watt | R ₆ —400 ohms, 10 watts |
| C ₃ —0.25- μ fd. tubular, 400 v. | R ₁ —500,000 ohm 1/4 or 1/2 watt midget resistor | R ₄ —50,000 ohms, 1 watt | T ₁ —Small 1-3 interstage a. f. trans. |
| C ₄ —.05- μ fd. tubular | | R ₅ —100,000 ohm pot., | L—See text |

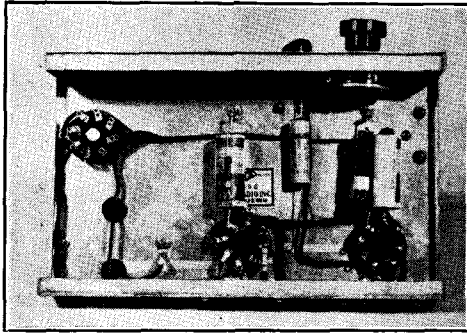

Figure 16.
UNDER-CHASSIS VIEW OF 224-MC.
RECEIVER.

means of a Trim Air bracket so that the lugs attach to the tank wires $2\frac{3}{4}$ inches up from the bolt through the bottom of the "U." The condenser is driven by means of an insulated shaft extension.

The antenna coupling loop is made of no. 12 enameled wire, bent as shown in figures

13 and 14, and varied with respect to the tank wires in order to vary the coupling.

Condenser C_7 should be grounded directly to the chassis with the shortest possible lead.

The receiver runs at full plate voltage at all times, the antenna coupling being adjusted to the closest value which will still permit superregeneration.

When the receiver is initially put into operation, the frequency range should be checked on Lecher wires. If slightly off, the frequency range can be altered sufficiently by varying the spacing between the two tank wires: spreading the wires slightly *lowers* the frequency. If the frequency is very far off, it will be necessary to alter the length of the tank wires slightly as required to enable the tuning condenser to cover the band.

112 MC. MOBILE TRANSCEIVER

With a few minor circuit changes and additional components, the 112 Mc. superregenerative receiver illustrated in figures 11 and 12 makes an excellent transceiver for mobile

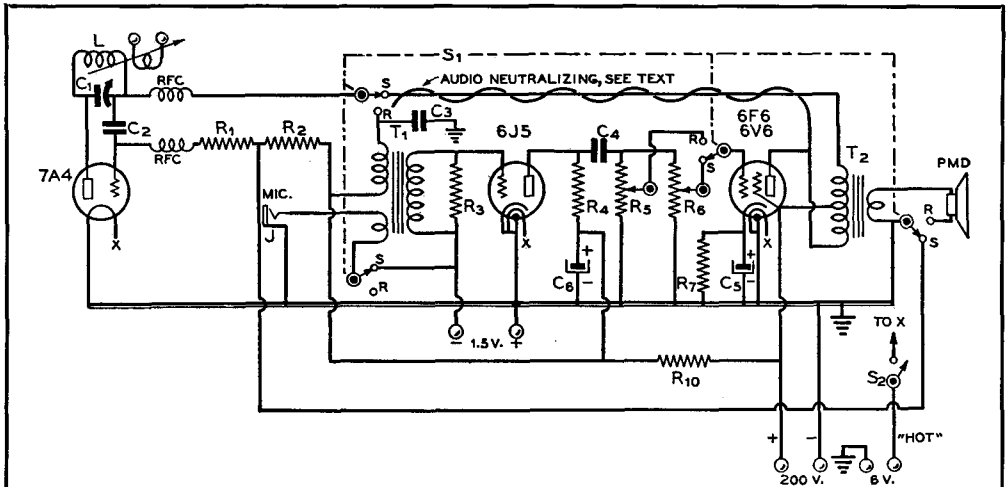

Figure 17.

112-MC. MOBILE TRANSCEIVER SCHEMATIC DIAGRAM

- | | | | |
|---|--|---|--|
| <p>C_1—5-μfd. double spaced midget condenser (with mounting bracket and ceramic shaft coupling)</p> <p>C_2—100-μfd. smallest mica condenser</p> <p>C_3—.01-μfd. tubular condenser, 400 v.</p> <p>C_4—.05-μfd. tubular condenser, 400 v.</p> | <p>C_5—10-μfd. 25 v. electrolytic</p> <p>C_6—8-μfd. midget tubular electrolytic, 450 v.</p> <p>R_1—2500 ohms, 2 watts</p> <p>R_2—1 meg., 1 watt</p> <p>R_3—100,000 ohms, $\frac{1}{2}$ watt</p> <p>R_4—100,000 ohms, 1 watt</p> | <p>R_5, R_6—100,000-ohm potentiometer, a.f. gain taper</p> <p>R_7—500 ohms, 5 watts</p> <p>R_8—7500 ohms, 1 watt</p> <p>RFC—Midget u. h. f. chokes</p> <p>J—Open circuit jack (a closed circuit jack will short the microphone battery)</p> <p>S_1—4-pole 2-throw rotary switch</p> | <p>S_2—S.p.s.t. toggle switch</p> <p>T_1—Transceiver transformer: plate and s.b. mike to single grid</p> <p>T_2—Universal output transformer: 14,000 ohm c.t. pri., adjustable voice coil winding</p> <p>PMD—Small p.m. dynamic speaker</p> |
|---|--|---|--|

Figure 18.
SELF-CONTAINED 112-MC.
TRANSCEIVER.

From a good vantage point, this little self-contained 112-Mc. transceiver has a range of several miles. The vertical rod radiator is supported as shown. Two bolts are soldered to the front lip supporting the hinged lid, and by removable thumb screws the lid either may be held down tightly for carrying by the handle or opened for access to the "works."

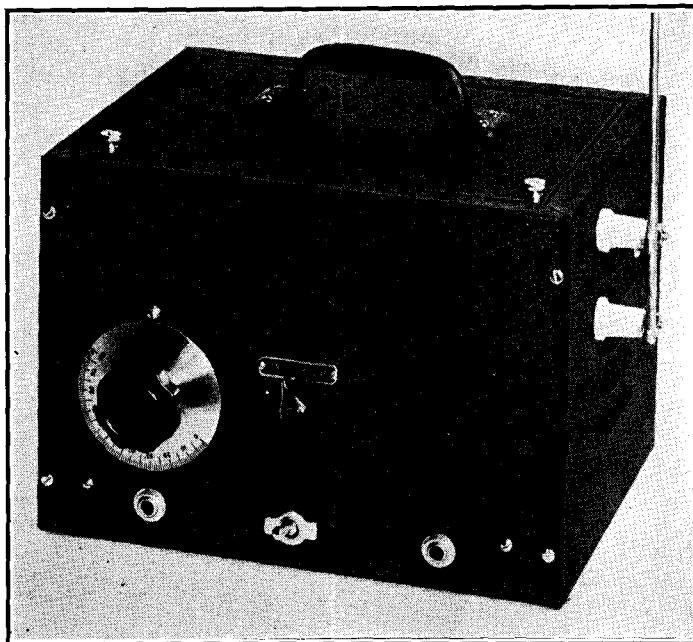

work. An output of between 2 and 3 watts, enough to deliver a strong signal over considerable distance, is obtainable at the maximum recommended plate voltage.

The layout is substantially the same as that for the receiver, illustrated in figure 11, and therefore is not shown here. Also, the remarks pertaining to the r.f. portion of the circuit, including tank coil, tuning condenser, and adjustable antenna coil, apply to the transceiver.

Dual volume controls are provided to permit independent adjustment of gain when receiving and when transmitting. Microphone voltage is obtained from a standard $1\frac{1}{2}$ volt dry cell, in order to avoid the possibility of vibrator or generator hash getting into the speech system through the 6 volt supply lead. The battery also provides C bias for the 6J5 speech or audio amplifier. Because the drain on the battery is so low, many hundreds of hours of transmission are possible before replacement is required.

To prevent a.f. feedback it may be found necessary to neutralize the capacity which exists between contacts on the send-receive switch. Should the a.f. system go into oscillation when the gain control is advanced, simply run a length of insulated wire from the plate of the output tube to the switch, this wire being twisted around the wire running

from the opposite end of the transformer to the switch. At the switch, the end of the free wire is adjusted with respect to the wire from T_1 (thus varying the capacity between them) until it is possible to run the gain full on both on transmit and on receive without a.f. feedback.

Occasionally such feedback can be eliminated simply by transposing the two secondary wires on T_1 , in which case the neutralizing lead will not be required.

The two r.f. chokes should have their leads clipped off short on the "hot" end to minimize the length of connecting wire between r.f. chokes and the tank circuit.

The adjustable antenna coupling serves as regeneration control, the detector running at high plate voltage at all times. The coupling always is adjusted to the closest value which will still permit superregeneration. This provides maximum sensitivity when receiving and maximum output when transmitting.

The plate supply voltage should not greatly exceed 200 volts on transmission, as excessive plate voltage will cause the 7A4 to overheat and the plate current to "run away."

An antenna system suited for mobile use with this transceiver is described in chapter 21. The distance which can be worked depends upon the antenna and the location; 50 miles is common from an elevated location.

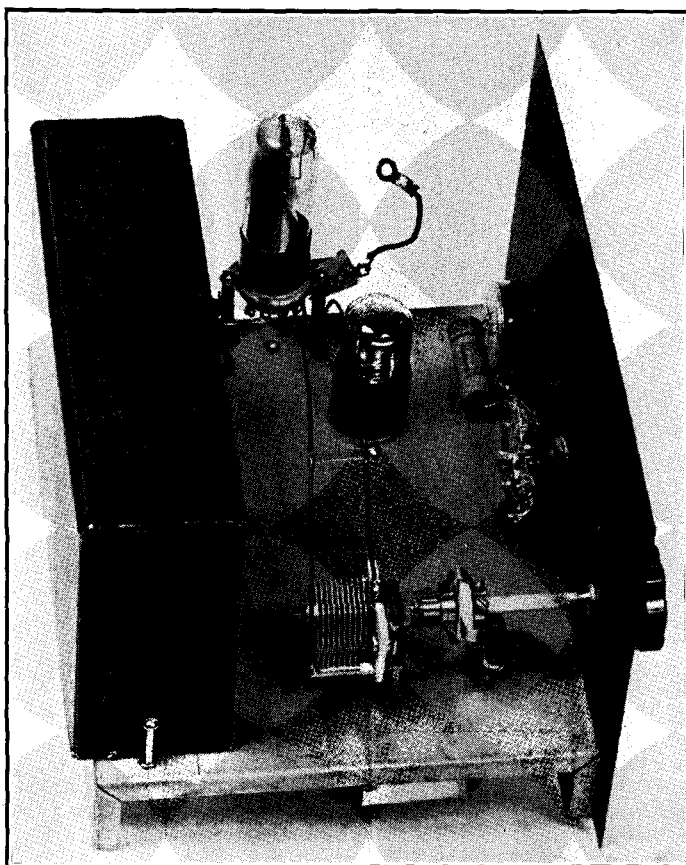

Figure 19.
LOOKING DOWN ON THE
TRANSCEIVER WITH CABI-
NET REMOVED.
The flexible lead terminated in
a solder lug must be unfas-
tened from the lower antenna
feedthrough insulator before
the unit can be slid out of the
cabinet.

SELF-CONTAINED, BATTERY POWERED TRANSCEIVER FOR 112 MC.

The small transceiver illustrated in figures 18-21 will provide reliable communication over a maximum distance of 20-25 miles when both stations (or their antennas) are within line of sight. It is entirely self-contained, being powered by a standard pack, and weighs but 13 lbs. (not including microphone or ear-phones). Cost of operation will be about $\frac{1}{2}$ cent per hour, the battery drain being quite low.

Construction. The transceiver is constructed in a standard manufactured cabinet measuring 7 x 10 x 8 inches deep, a $7\frac{1}{2}$ x 9 inch sub-chassis measuring $1\frac{1}{2}$ inches high being supported from the front panel. These items are made by a well known manufacturer and are commonly stocked throughout the country.

The 1G4G socket, which should be of polystyrene, is mounted by means of two $1\frac{1}{2}$ -inch bushings and $1\frac{3}{4}$ -inch bolts. The bolts are mounted in holes drilled exactly $\frac{3}{4}$ inch in from the edge of the chassis. The holes should be located so that the center of the socket is exactly 4 inches from the front panel. The socket should be oriented so that the ridge on the locating pin on the tube points towards the rear.

The socket for the 1T5-GT is mounted with the center about $2\frac{1}{4}$ inches back from the front panel, and about $2\frac{1}{4}$ inches in from the right hand edge of the chassis.

As both sides of the tuning condenser C_1 are "hot," the condenser is mounted by means of an accessory bracket offered by the manufacturer of the condenser. This bracket bolts to the ceramic portion of the condenser, and does not touch either rotor or stator. The bracket is raised up off the chassis by means of two $\frac{1}{2}$ -inch collars and $\frac{3}{4}$ -inch 6-32 bolts.

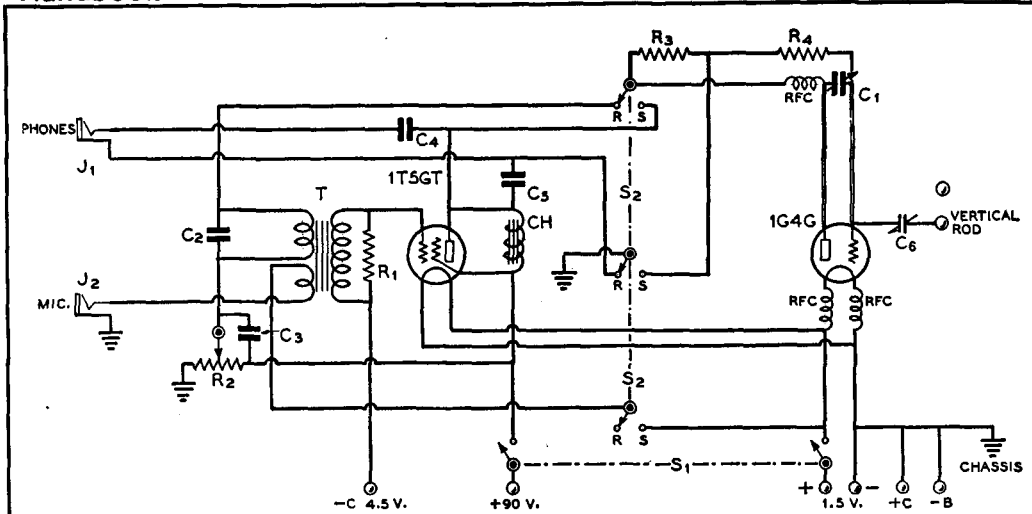

Figure 20.

WIRING DIAGRAM OF THE SELF-CONTAINED TRANSCEIVER.

C_1 —100- μ fd. midget condenser, ceramic insulation	C_6 —3-30- μ fd. mica trimmer, ceramic insulation, screw removed	R_4 —25,000 ohms, $\frac{1}{2}$ watt	S_1 —D.p.s.t. toggle switch
C_2 —0.01- μ fd. midget mica	R_1 —100,000 ohms, $\frac{1}{2}$ watt	CH—Midget 7 to 10 hy. choke, 15 ma. or more	S_2 —4 pole 2 throw rotary "send-receive" switch
C_3 —0.1- μ fd. 200 or 400 volt tubular	R_2 —100,000 ohm potentiometer	T—Transceiver type midget dual purpose a.f.t., plate and single button mike to grid	J_1, J_2 —Open circuit jacks
C_4 —0.1- μ fd. 200 or 400 volt tubular	R_3 —1 meg., $\frac{1}{2}$ watt		RFC—U.h.f. type chokes, not over 1 ohm d.c. resistance
C_5 —0.1- μ fd. 400 volt tubular			

If this were not done, the tuning dial would sit too low on the front panel.

Holes for mounting the condenser bracket should be so drilled that the condenser shaft is exactly $1\frac{3}{4}$ inch in from the edge of the chassis or $2\frac{1}{4}$ inches in from the edge of the front panel. A hole is drilled in the front panel bearing, $2\frac{1}{4}$ inches in from the edge of the panel and at the same height as the condenser shaft. A flexible, ceramic insulated coupling unit is used to drive the tuning condenser. A short piece of $\frac{1}{4}$ -inch steel, brass, lucite, or bakelite rod is used to connect the dial to the flexible coupling. The condenser should be mounted so that the ceramic front plate is exactly 3 inches back from the panel.

The send-receive switch S_2 is mounted so that the shaft is at the same height as the tuning condenser shaft, and midway between the right hand and left hand edges of the panel. The regeneration control R_2 is mounted exactly $2\frac{1}{4}$ inches in from the right hand edge of the front panel and at the same height as the other controls. As may be seen from the illustration of the front panel, the two jacks and the on-off switch are lined up directly

underneath the three controls, $\frac{3}{4}$ inch from the bottom edge of the panel.

The small $4\frac{1}{2}$ -volt C battery is held in place by means of a bracket bent out of a small piece of galvanized iron, soldered to the edge of the chassis. The battery is slipped under this bracket and held firmly in place by means of a small angle bracket which is screwed to the positive battery terminal and bolted to the chassis. This not only holds the battery in place, but furnishes a connection from C plus to chassis (ground).

In order to permit mounting of the small u.h.f. filament chokes as close as possible to the 1G4G, two $\frac{1}{2}$ -inch holes are drilled near the socket. The chokes are mounted half above and half below the chassis, the leads to the socket pins being only a fraction of an inch long when the chokes are mounted in this manner. Each choke should have not over 1 ohm d.c. resistance or the filament will not receive rated voltage.

The linear tank consists of two lengths of no. 12 enamelled wire, spaced about $\frac{1}{2}$ inch. Enamelled wire should be used; tinned wire will have higher losses and bare wire endan-

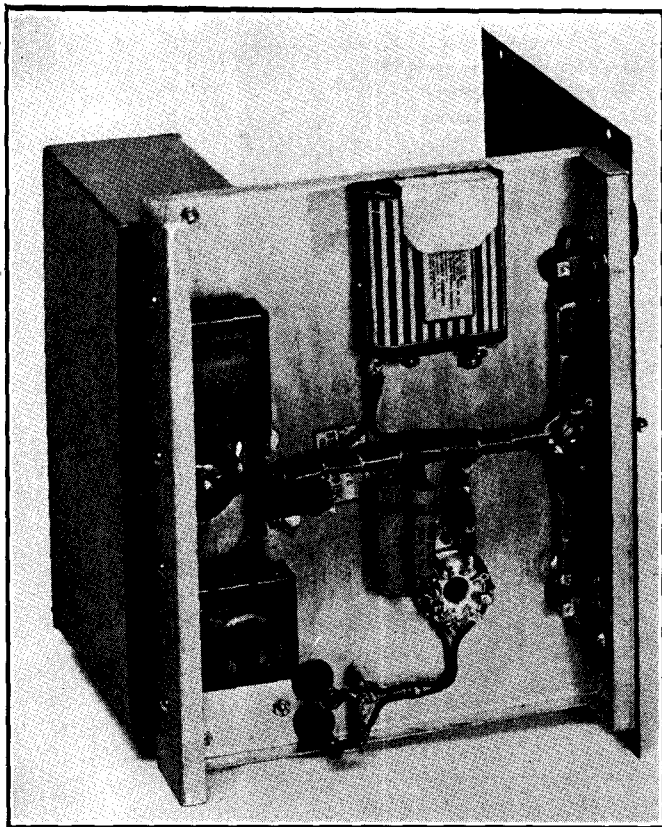

Figure 21.
UNDER-CHASSIS VIEW OF
THE TRANSCEIVER.

Wires underneath the chassis need not be made short. Observe method of holding C battery by means of large stationary and small removable bracket, latter bolted to positive terminal and chassis.

gers the tube. When bare wire is used, the 1G4G can be permanently damaged with the switch on the "receive" position simply by touching both grid and plate wires with a hand moist with perspiration. This puts a positive bias on the grid, and the tube does not have a husky enough filament to stand such treatment without harm.

Some alteration of the length of the tank elements may be necessary after the transceiver is fired up and the frequency checked by means of Lecher wires, but to start off with the following dimensions should be used. Grid (front) wire: 9 inches. Plate (rear) wire: $9\frac{1}{2}$ inches.

The grid wire is deliberately made shorter than the plate wire, because the extra half inch is made up when the antenna coupling condenser is soldered to the grid prong of the 1G4G socket.

The grid wire solders directly to the rotor lug of the tuning condenser and the plate wire to the *farthest* stator lug. The wires are bent in the shape of a half moon, as shown in the

illustration. The small grid resistor R_4 and the plate r.f. choke are soldered to the tuning condenser with the shortest possible leads. As previously mentioned, the antenna coupling condenser C is soldered directly to the grid prong of the 1G4G socket; be sure that the *stationary* plate is soldered to the grid prong.

The battery pack is mounted upside down as far to the rear as the cabinet will allow. This means that the battery overhangs the rear of the chassis about $\frac{1}{2}$ inch. A socket size hole is punched or drilled in the chassis to accommodate the leads from the battery. This is all clearly illustrated in the bottom view.

To keep the battery firmly against the rear of the cabinet, a piece of brass rod or tubing is cut the exact width of the cabinet and tapped at each end for a 6-32 bolt. Two holes are drilled in the sides of the cabinet so that when the tubing is bolted in place the battery pack is held firmly in position. Small blocks of wood between battery and

cabinet or a couple of 1-inch 6-32 bolts protruding from the chassis can be used to keep the battery pack from slipping sidewise.

The antenna consists of a vertical half-wave rod, capacitively coupled to the grid of the tube. Better results, both receiving and transmitting, are obtained with the antenna coupled to the grid rather than the plate. The length of the antenna, *overall*, from the tip of the rod to the coupling condenser C_6 should be exactly 3 feet 6 inches. This is not quite as long as the usual 114-Mc. dipole, but it is an electrical half wavelength just the same because of the loading effect of the coupling condenser C_6 .

The antenna rod proper is 3 feet 3 inches long. The rest of the length is made up by the feed-through insulator bolt and the $1\frac{1}{2}$ inch flexible lead to the coupling condenser. The two medium-sized feed-through insulators are mounted one above the other, their centers $2\frac{3}{8}$ inches back from the front edge of the cabinet. They are spaced $1\frac{3}{4}$ inches and the top insulator is $\frac{7}{8}$ inch below the top edge of the cabinet. The top insulator does not connect to anything; it merely serves to hold the antenna rod vertical. The two threaded rods for the feed-through insulators should be sawed off so that they are no longer than necessary, in order to reduce the stray capacity to ground (cabinet) as much as possible.

Inspection of the wiring diagram will show that the filament switch S_1 also opens the B

negative. This is necessary to prevent a continuous drain on the B battery by R_2 .

When the linear tank covers the band correctly (a small amount of leeway on either side), the circuit elements should be stiffened up to make them less susceptible to vibration. A small piece of celluloid or victron is cut to make a "spreader" by cutting it about $\frac{1}{8}$ inch longer than the separation of the parallel wires at a point about one-third of the way up from the tuning condenser. The ends of the spreader are notched with small "V" indentations with a pair of diagonals and the wires are pulled apart slightly to take the spreader. The wire is crimped a little either side of the spreader to provide a "bite" for duco cement, which is applied to hold the spreader firmly in place.

The circuit will not oscillate when the tuning condenser is tuned to less than $\frac{1}{3}$ of maximum capacity. This means that only two-thirds of the scale is usable, but this is unimportant because the entire $2\frac{1}{2}$ meter band covers less than half the dial.

Next, the antenna coupling should be varied by adjusting the distance between the movable and the stationary plate. Closer spacing provides tighter coupling. The coupling should be increased to as much as will still permit superregeneration over the entire band, and then left alone. Ordinarily this adjustment will be about the same as the position assumed by the movable plate when the adjusting screw is removed.

CHAPTER NINETEEN

Ultra-High-Frequency Transmitters

The frequencies above 30 megacycles are generally called the ultra-high frequencies or the ultra-short wavelengths. Four amateur bands fall on frequencies above 30 Mc.; the 56 to 60 Mc., 112 to 116 Mc., 224 to 230 Mc., and 400 to 401 Mc. bands. Equipment designed for use in these frequency ranges is generally quite different from the equipment designed for use below 30 Mc. Hence, this chapter will deal with the practical design of transmitters for use within the limits of these bands.

The primary activity on the u.h.f. bands is telephony, although some i.c.w. and occasionally some c.w. is heard. On the 5-meter band (56 to 60 Mc.) radiophone transmitters are either crystal controlled or m.o.p.a. with a very high-Q self-excited oscillator and preferably at least one buffer stage. Modulated oscillators are not suitable for use on the 5-meter band, as the stability requirement set forth in the FCC regulations automatically rules them out. Frequency modulated transmission is, however, permitted in the range from 58.5 to 60 Mc., and on all frequencies within the bands above 60 Mc.

On $2\frac{1}{2}$ meters (112-116 Mc.), $1\frac{1}{4}$ meters (224-230 Mc.), and $\frac{3}{4}$ meters (400-401 Mc.) the FCC is more lenient, and modulated oscillators are permitted in the interest of simplicity. However, some attempt at stabilizing the oscillator is usually made, and the advantages of m.o.p.a. transmitters are the same as on the low-frequency bands, when greatest simplicity is not needed. Oscillator stabilization is usually accomplished through the use of high-Q circuits, particularly in the grid circuit. High Q is obtained through the use of linear tanks (parallel rods or pipes) or by concentric tanks. The circuit Q is often increased still further in the grid circuit by tapping down on the quarter-wave

grid line for the grid connection to the tube.

Portable and mobile operation on frequencies above 112 Mc. can be accomplished with a minimum of equipment through the use of transceivers, or combined transmitter-receivers; these have been described in the previous chapter.

Chapter Subdivisions. In order to classify the types of equipment used on the ultra-high frequencies and the micro waves, this chapter will be subdivided into the following divisions: Oscillators and M.O.P.A. Transmitters, Crystal Controlled Transmitters and U.H.F. Amplifiers, Frequency Modulation Transmitters, and Micro-Wave Transmitters.

OSCILLATORS AND M.O.P.A. TRANSMITTERS

The majority of the equipment to be shown under this heading will be of the simple oscillator type, since this type of equipment is quite adequate for experimental 112- and 224-Mc. communication. However, when greater frequency stability is desired, it is always advisable to place an amplifier or frequency multiplier between the oscillator and the final amplifier which is to be keyed or modulated. Some of the newer u.h.f. triodes such as the HK-24, 35TG, HY-75, and 1628 can be operated quite efficiently as push-pull triplers and will allow quite satisfactory neutralization in a push-pull amplifier when the conventional cross connected neutralizing circuit is used. Single ended amplifier stages can be neutralized most satisfactorily by the coil or inductive neutralization circuit shown under *Transmitter Theory*. The "coil" in this case can best be a short section of closely spaced open-wire line to resonate to the operating frequency by the grid-to-plate capacity.

U.H.F. Push-Pull Beam Tubes. Within the last few months several excellent push-pull u.h.f. beam tubes have made their appearance: 829, 815, etc. These tubes make excellent push-pull r.f. amplifier stages at 56, 112, and 224 Mc. and they have the advantage that, if the input circuit is properly shielded from the output, no neutralization will be required.

112-Mc. Equipment

20-Watt HY-75 Oscillator. This little transmitter was primarily designed to replace the final amplifier stage of a ten-meter mobile transmitter and to be modulated by the speech and modulator system which was originally used with the ten-meter transmitter. It consists of an HY-75 ultra-audion oscillator with conventional coil-and-condenser tank circuit. A concentric pipe or parallel rod oscillator would undoubtedly give greater stability, but with a low capacity, high transconductance tube the stability has been found sufficiently good with the tank circuit shown. The only precautions that need be taken in the construction of the transmitter is to make sure that all r.f. leads are as short as possible, that all parts are mounted rigidly, and that good u.h.f. insulation be used where it is in contact with high potential r.f. The tuning condenser should be of the ultra midget type, and it should be wired so that the rotor goes to the grid. The exact number of turns for the tank coil will depend somewhat on the physical layout and particular make of components chosen. Some pruning may be required on the coil. It should hit the band when the tuning condenser is about half meshed. Observe that both rotor and stator are hot to ground, both to d.c. and r.f.

The tube socket is not exposed to r.f., and may be of the inexpensive wafer type. It is important that the tube be mounted in a vertical position for good filament life.

Figure 1 shows a back view of the oscillator. It has been mounted upon this small chassis so as to take up as little space as possible when placed alongside the modulator system for the mobile ten-meter transmitter. Normal operation of the oscillator will be with 300 volts at about 80 ma. on the plate. If desired, the power input may be raised to 425 volts at 80 ma. to give about 35 watts input. The circuit diagram of the oscillator is shown in figure 2.

Inexpensive 8-Watt Oscillator and Modulator. For the amateur who wishes to build an inexpensive low-power station transmitter for 112 Mc., the unit shown in figure 3 and

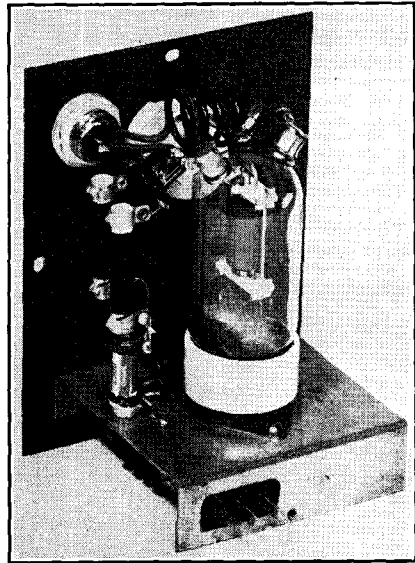

Figure 1.

20-WATT 112-MC. OSCILLATOR.

This diminutive oscillator will take 35 watts input on 112 Mc., and will deliver quite a substantial signal on the band. The tube clips are connected to the tank condenser by means of narrow copper ribbon. A one-turn link at the grid end of the tank connects to a coaxial cable connector.

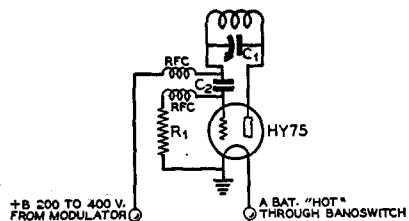

Figure 2.

SCHEMATIC OF THE HY-75 112-MC. OSCILLATOR.

- C_1 —15- μ fd. sub-midget condenser
- C_2 —.0001- μ fd. midget mica
- RFC—U.h.f. choke
- R_1 —2500 ohms, 1½ watts
- Coil—4 t. no. 14 enam., ¼" dia. spaced to hit band

diagrammed in figure 4 is ideal. It uses inexpensive tubes throughout, is built upon a breadboard, and has a quite respectable power output capability.

The oscillator is built on a baseboard measuring 5 x 23 x ¾ inches. The two rods

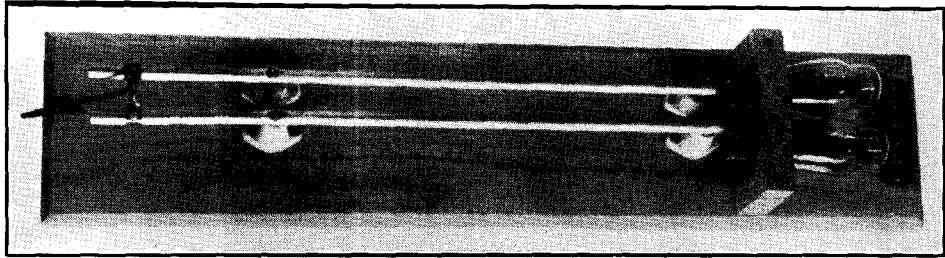

Figure 3.

112-MC. BREADBOARD OSCILLATOR USING PUSH-PULL TRIODES.

The oscillator is built breadboard fashion, with connections made directly to the tube prongs. The linear tank circuit permits comparatively high efficiency and gives an output of 8 to 10 watts. A suitable modulator and power supply are shown in figure 4. 6P5-GT's or 7A4's may be substituted for the 76's shown if desired; it will be necessary to lengthen the rods about one-half inch with the 6P5-GT's and 7A4's.

are each $15\frac{1}{2}$ inches long, of either copper or aluminum $\frac{3}{8}$ inch o.d. tubing. They are supported on $1\frac{1}{2}$ -inch standoff insulators, placed as shown.

The "stock" supporting the tubes is made from a block of wood measuring $4\frac{1}{4} \times 2\frac{1}{2} \times \frac{3}{4}$ inches. The grain should run the long way of the block. Holes are drilled just large enough to take the bases of the tubes, their centers $1\frac{5}{8}$ " apart and $\frac{7}{8}$ " from one of the $4\frac{1}{4}$ " edges. Now with a rip saw, cut the length of the block parallel to the long edges, through the centers of the two socket holes. The tubes will be held firmly, with a viselike grip, when two screws are run down through the assembly and into the baseboard 5 inches from one end of the latter.

This method of mounting the tubes, and soldering direct to the tube prongs, permits shorter leads than could be obtained with any type socket, as even socket terminals represent objectionable lead length at this frequency.

Bakelite tube bases show rather high losses at $2\frac{1}{2}$ meters, but it is possible to reduce these losses by putting two hacksaw slots in the base of each tube, between the plate and grid prongs. Be sure to saw all the way through the base (about $1/16$ "), but don't go any farther or you may saw into the glass tip that seals the stem of the tube.

The grid coil is soldered directly to the grid prongs of the tubes, which should be mounted with the grid prong (the isolated prong) upward. The coil consists of 5 turns of no. 14 enamelled, spaced to approximately $\frac{5}{8}$ ". The exact spacing constitutes tuning of the grid circuit. The carbon resistor which serves as a grid leak is mounted vertically between the grid coil and the wood "stock." The top of the resistor is soldered to the center turn of the grid coil (top of the coil) and the

other resistor lead is soldered to the jumper which connects the two 76 cathodes.

The sliding jumper for the plate tank is constructed by soldering together two of the older type grid clips which just slip over a $\frac{3}{8}$ " diameter. These make firm contact to the rods, and can be slid along by pressing upon the two "tongues" while attempting to slide them. The lead from this jumper runs underneath the baseboard *midway between the two tank rods* to prevent unbalancing of the circuit.

Tuning. The oscillator is tuned by placing the shorting bar $14\frac{1}{2}$ inches from the plate end of the plate tank rods. With the antenna disconnected, squeeze the grid coil in and out until the oscillator draws 50 ma. It should be possible to draw small sparks from the plate end of the rods with the tip of a lead pencil, indicating oscillation. The antenna is now coupled to the plate tank by means of hairpin link, the coupling being adjusted until the oscillator draws 60 ma. Tighter coupling should not be used, as the life of the 76's will be greatly shortened if they are allowed to draw over 60 ma. for any length of time. The output under these conditions will be very close to 8 watts.

The microphone jack, MIC, must be of the closed circuit (shorting) type. Otherwise the low voltage by-pass condenser C_1 will be blown when the microphone plug is removed.

100-Watt 75T Resonant-Line 112-Mc. Oscillator. Figures 5 and 6 illustrate a concentric line controlled 112-Mc. oscillator using a 75T, which will put out approximately 100 watts of stabilized r.f. on any frequency in the 112-116 Mc. amateur band. A short concentric line, which is resonated to the operating frequency by means of a $35\text{-}\mu\text{fd.}$ midget variable, acts as the frequency deter-

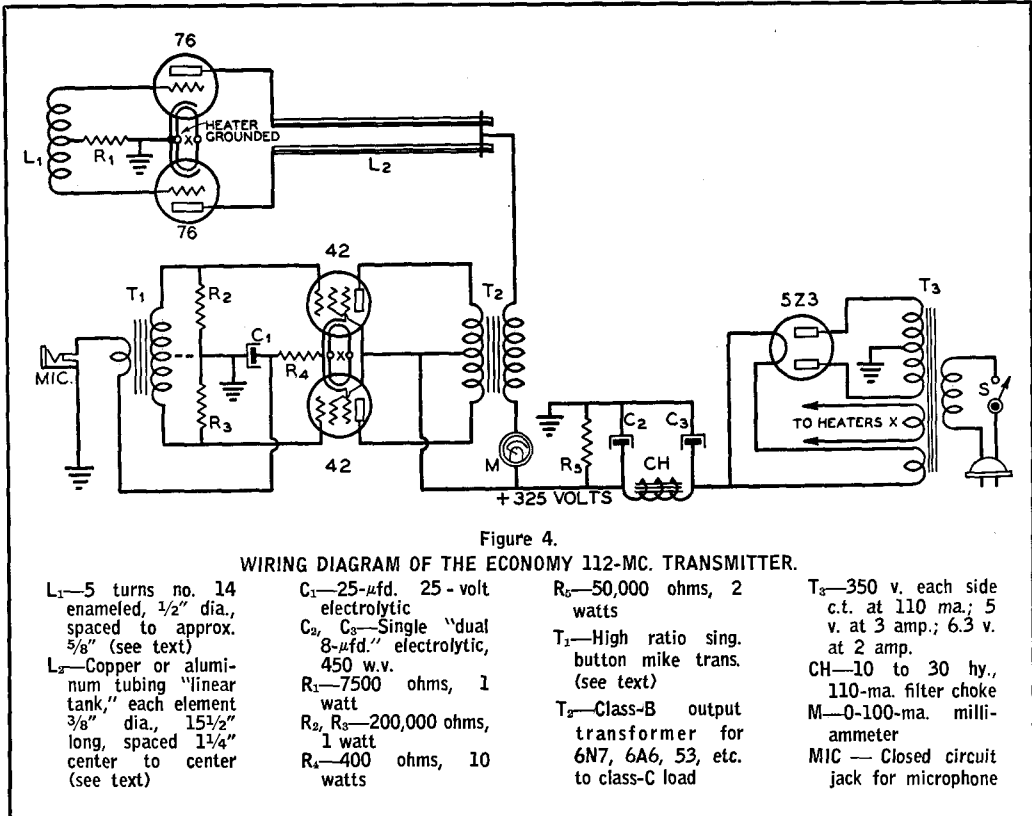

mining element; output power is taken from a self-resonant coil in the plate circuit.

The concentric line itself is 12 inches long and $2\frac{7}{8}$ inches inside diameter ($3''$ o.d. with $1/16''$ wall), and the inner conductor is $13\frac{1}{4}$ inches long and $\frac{3}{4}$ inches in diameter. Both pieces which make up the line are cut from standard lengths of thin-wall copper water pipe. To make up the line first the inner conductor is soldered to the center of a piece of 20-gauge copper sheet about $3\frac{1}{2}$ inches square with the aid of a small alcohol torch and a soldering iron. Then the outer conductor is slipped over it and also soldered in place. Considerable heat is required to do the soldering, but if the work is placed on a block of wood as insulation, a small alcohol torch and a conventional electric soldering iron will do the job quite easily. The wood will be thoroughly charred when the work is finished but it will have served its purpose. Asbestos would probably be better but wood will be satisfactory.

A hole is drilled in both the inner and the outer conductor $2\frac{1}{4}$ inches up from the base

on the line. Then another hole is drilled in the center of the base so that a wire may be run through it, through the inner conductor, and then through the hole $2\frac{1}{4}$ inches up through both the inner and outer conductor to connect to the grid of the tube. This wire is by-passed immediately to ground and one side of the filament of the 75T as it leaves the base of the line.

The plate coil consists of three turns of no. 12 wire $1\frac{1}{4}$ inches in diameter and 2 inches long. The upper end of this coil is by-passed to the concentric line by means of a .0001- μ fd. 5000-volt mica condenser. This plate coil was found to resonate over the entire $2\frac{1}{2}$ -meter band with the plate-to-ground capacity of the 75T and the distributed capacity of the circuit.

With the circuit constants shown the grid condenser will tune the oscillator to the center of the $2\frac{1}{2}$ -meter band when it is about half meshed. About 30° rotation of the condenser will cover the band. Approximately 100 watts output may be obtained from the oscillator at 1250 plate volts and at a plate efficiency of 50 to 65 per cent.

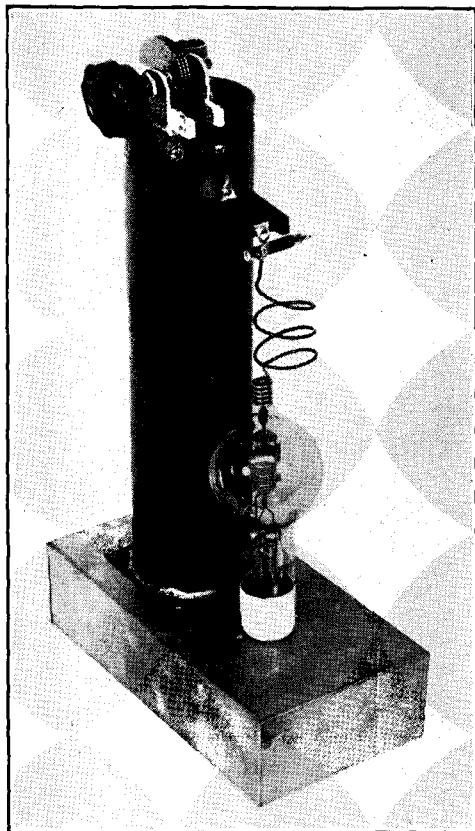

Figure 5.
CONCENTRIC-LINE 75T OSCILLATOR.
This concentric-line oscillator with a 75T gives good stability and a quite reasonable power output on the 112-Mc. band.

224-Mc. Equipment

Within the last few months a great deal of interest has been centered on the 224-Mc. band due to the peculiar conditions which exist upon it, and due to the fact that, for a given amount of power, greater signal strength is obtainable over an optical path than with use of any of the lower frequencies.

A 2-Watt 7A4 Oscillator. Figure 7 shows a 224-Mc. oscillator using a 7A4 which can be used either as a transmitter to give about 2 watts output, or as a superregenerative detector to feed an audio amplifier as a receiver. The unit as shown, and as illustrated in the circuit diagram, is set up as a low-power 224-Mc. oscillator. For this use the grid leak R should be 7500 ohms and should be connected between the grid of the 7A4 and

Figure 6.
SEMI-SCHEMATIC OF THE 75T OSCILLATOR.

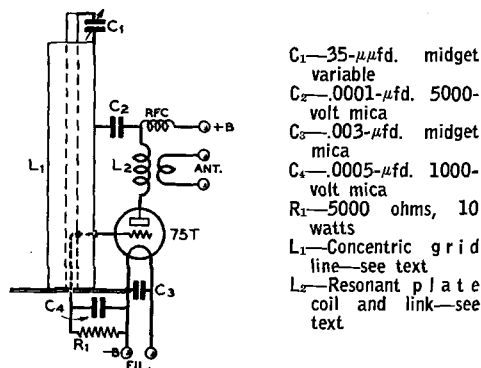

ground. For the proper method of tuning this oscillator to a given frequency in the $1\frac{1}{4}$ -meter band through the use of Lecher wires, see the chapter *U.H.F. Communication*.

As an oscillator the plate voltage on the 7A4 should be limited to 250 volts and the plate current should not be greater than 30 ma. The resting plate current of the oscillator, unloaded, will be about 18 to 20 ma.; when the circuit is loaded to 30 ma. about 2 watts may be taken from the antenna coupling link.

The plate hairpin of the oscillator is made from no. 10 bare copper wire (actually no. 10 enamelled wire from which the enamel has been scraped); it is bent into a narrow hairpin with about $\frac{3}{32}$ " spacing between the wires. The length from the turn on the loop where the plate voltage connection is made to the plate of the tube is $4\frac{1}{2}$ ". The length along the other side of the loop from the plate voltage connection to the grid condenser is $3\frac{1}{4}$ inches. Quite a wide adjustment in frequency may be obtained by varying the spacing between the wires in the hairpin. Decreasing the spacing *increases* the frequency, and increasing the spacing decreases the frequency of oscillation. It is quite simple to vary the frequency of oscillation from about 180 Mc. up to 230 Mc. merely by making a comparatively small adjustment in the spacing from just over $\frac{1}{8}$ " to $\frac{3}{32}$ ".

To convert the oscillator into a superregenerative detector it is only necessary to remove the 7500-ohm resistor that goes from the grid to ground and then to place a 500,000-ohm resistor directly across the grid condenser. Making the return of the grid leak to positive high voltage in this manner greatly

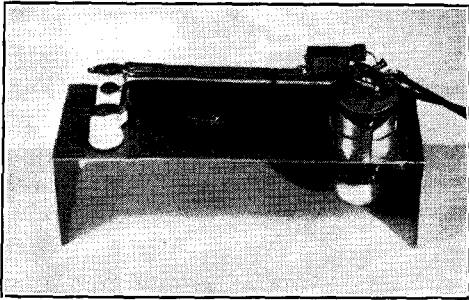

Figure 7.
2-WATT 224-MC. OSCILLATOR.

This simple and inexpensive oscillator may be used either as a low-power transmitter on the 1/4-meter band or, by a slight circuit alteration, as a 224-Mc. band superregenerative receiver.

increases the output of the tube when operating as a detector, as compared to when it is returned to ground. Note that it is necessary to have the .003- μ fd. by-pass condenser from the plate return to ground for the tube to superregenerate.

An HY-75 8-Watt Oscillator. Another 224-Mc. oscillator using a hairpin as the resonant line is illustrated in figure 9 and diagrammed in figure 10. The lead lengths from the center of the hairpin to the plate of the HY-75 and to the grid condenser are the same as for the 7A4 oscillator just described. An r.f. choke has been used between the grid and the grid leak because of the comparatively low value of resistance of this leak resistor. It was not required in the 7A4 oscillator because of the considerably higher grid-leak resistance. A grid-leak resistance

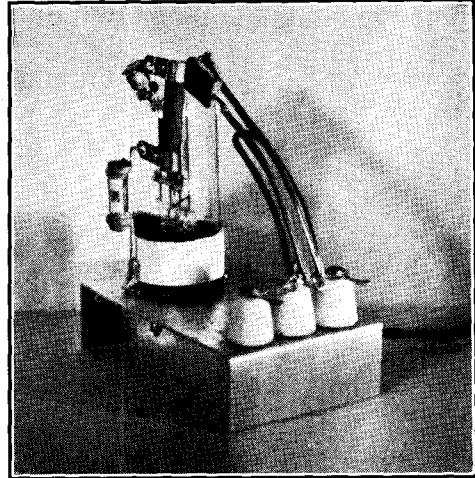

Figure 9.
8-WATT HY-75 224-MC. OSCILLATOR

This small HY-75 transmitter is ideal for the amateur who wishes a medium-power 1/4-meter oscillator for both fixed station and portable use.

from 3000 to 4000 ohms has been found to be best for the HY-75 in this circuit.

The operating voltage on the HY-75 should be from 275 to 300 volts. The unloaded plate current of the oscillator will be about 30 to 35 ma. and it can safely be loaded to 75 or 80 ma. before excessive plate heating takes place. With this value of power input, the output will be from 8 to 10 watts.

A Push-Pull HY-75 Oscillator. The unusual parallel-rod push-pull oscillator shown in figure 11 and diagrammed in figure 12 has proven to be quite a satisfactory source of power for experiments in the 224- to 230-Mc. amateur band. A parallel-rod line is used as the frequency controlling element and a small self-tuned coil is used in the plate circuit.

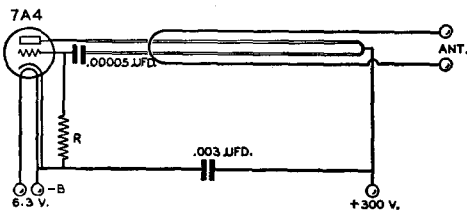

Figure 8.
SCHEMATIC OF THE SIMPLE 7A4
224-MC. OSCILLATOR.

The resistance R should be 7500 ohms for operation of the oscillator as a transmitter. For operation as a superregenerative detector, R should be removed and a 500,000-ohm resistor placed across the grid condenser. The plate circuit of the 7A4 may then be fed into a conventional audio amplifier.

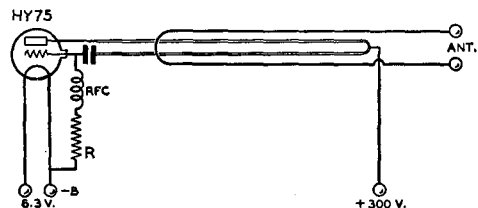

Figure 10.
SCHEMATIC OF THE HY-75 224-MC.
OSCILLATOR.

The grid leak R should have a resistance of about 3000 ohms for normal use. The grid condenser should have a value of .00005 μ fd.

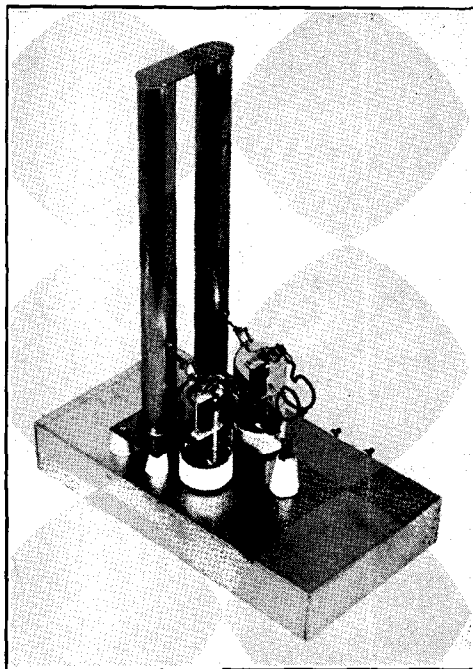

Figure 11.
PUSH-PULL 224-MC. HY-75 OSCILLATOR.

The resonant line is made up of two $\frac{7}{8}$ inch, thin-wall copper pipes spaced $\frac{7}{8}$ inch, $9\frac{1}{2}$ inches long overall, and connected together both at the top and bottom to act as a half-wave line instead of the more common quarter-wave arrangement. The base for the line is a piece of 20-gauge sheet copper $1\frac{3}{4}$ " by 4" which is mounted above the $9\frac{1}{2}$ " by 5" by $1\frac{1}{2}$ " chassis by means of one-half inch stand-off insulators.

The capacity to chassis of the copper base plate acts as a by-pass for the center of the parallel-rod line. The copper plate can be proven to be acting normally as a by-pass since its center will be quite cold to r.f. One of the standoffs which supports the copper plate is of the feedthrough type and has the grid leak connected between its lower end and the grounded side of the filaments of the tubes.

The power output of the oscillator as shown is 20 to 25 watts with 450 volts on the plates of the tubes. The plate efficiency is approximately 40 per cent with the half-wave line in the grid circuit as shown. The plate efficiency was somewhat less than this until the original quarter-wave grid line was replaced with the capacity-shortened (grid-to-ground capacity) half-wave line.

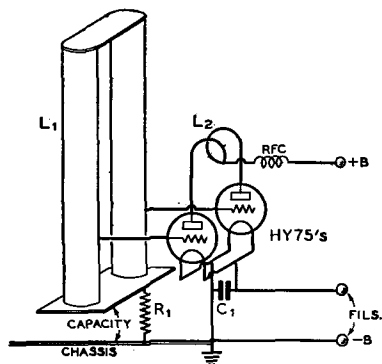

Figure 12.
SEMI-SCHEMATIC OF THE PUSH-PULL 224-MC. OSCILLATOR.

C_1 —0.003- μ fd. midget mica	L_2 —2 turns $\frac{5}{8}$ " dia., 1" long
R_1 —5000 ohms, 10 watts	RFC—6 turns hookup wire, $\frac{1}{4}$ " dia.
L_1 —Half-wave parallel-rod line	

50-Watt 225-Mc. 829 M.O.P.A. Transmitter. Figures 13 and 14 illustrate a very interesting 225-Mc. transmitter of quite respectable power handling capabilities. This transmitter is particularly interesting in the fact that it is an oscillator-amplifier affair instead of being merely an oscillator as are most transmitters for this high a frequency. The fact that the final stage is an amplifier indicates that it is quite possible to double down to a frequency as high as 225 Mc. for crystal controlled or frequency modulation transmission and still be able to find an arrangement which will be capable of operating as an amplifier at this extremely high frequency. As a matter of fact, the 829 amplifier stage operates with a plate efficiency of about 60 per cent when fully loaded, and requires a driving power of less than five watts actual output from the preceding stage.

The 829 tube itself is particularly designed for operation as an r.f. amplifier for frequencies above 50 Mc. It consists of a pair of beam tetrodes with a total plate dissipation of 40 watts mounted inside an envelope in which lead length has been made a primary consideration. The tube has no base, the terminal leads for the tube elements being brought out to tungsten rods which extend through the glass bottom plate of the envelope.

The socket for this tube is also very interesting and it, in addition, is particularly designed for u.h.f. use. The photographs give a good general idea of its construction: all the leads which are normally cold, heaters,

Figure 13.
TOP VIEW OF THE 829
M.O.P.A. 225-MC. TRANS-
MITTER.

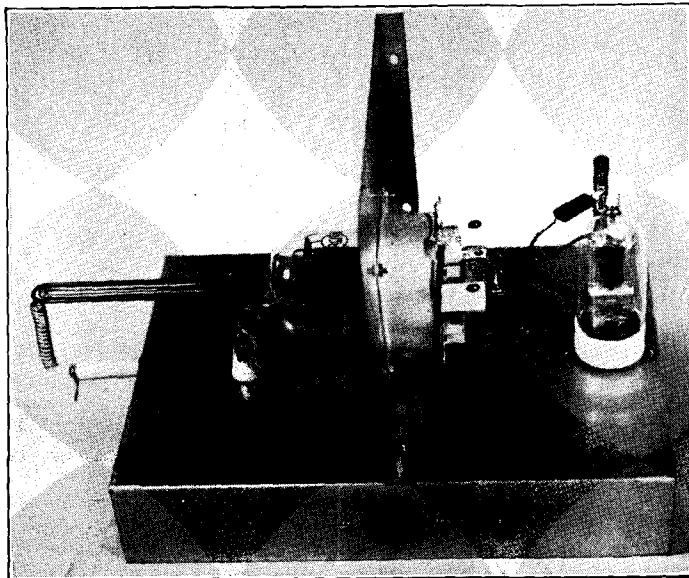

cathode, and screens, are brought out through large terminal clips which have built-in mica by-pass capacitors. Then, the grid leads to the two elements within the envelope are brought out to a separate mycalex arbor which is supported away from the base of the socket by means of small ceramic pillars.

The general layout of the HY-75 oscillator which is used as the exciter for the 829 can be seen in the top view photograph. The oscillator circuit is an ultra-audion, with a combination resonant line and coil in the plate circuit. The lead from the plate extends about $1\frac{1}{2}$ " and the lead from the grid condenser about $\frac{1}{2}$ " and then they are crossed over to form a one-turn coil. Another one-turn coil is interwound with this and connected to the two grid terminals on the 829 socket. The schematic diagram, figure 15, gives a general idea of the arrangement of these two circuits but it does not indicate graphically the fact that the two one-turn coils are interwound—at least in as much of a manner as two one-turn coils can be interwound.

If desired, the frequency of the HY-75 oscillator may be controlled by a quarter-wave concentric line, in the same general fashion as the frequency of the 75T 112-Mc. oscillator is controlled. The grid of the HY-75 should be tapped up a short distance from the bottom of the capacity loaded line, and the plate return made to the side of the line in the same manner as the 75T oscillator de-

scribed previously. An alternative arrangement would be to use the HY-75 as a frequency doubler from the 112-Mc. band for crystal controlled or FM transmission. The plate and grid circuits of the 829 amplifier would be the same as shown, and the plate tank of the HY-75 would be returned to ground with the 112-Mc. excitation fed to the grid.

The normal plate voltage of the 829 is 400 volts, the screen voltage is 200 volts, and the grid bias should be 35 to 45 volts. The grid current of the 829 as shown is about 8 to 9 ma. through a 4000-ohm grid leak. The amplifier operates very satisfactorily with a

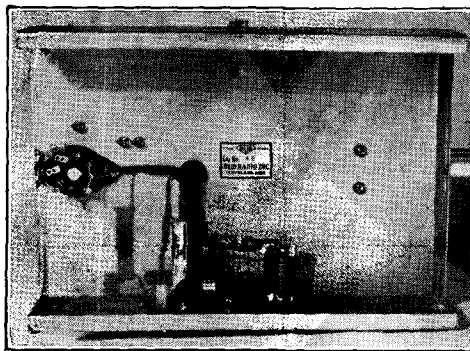

Figure 14.
BOTTOM VIEW OF THE 829 TRANSMITTER.

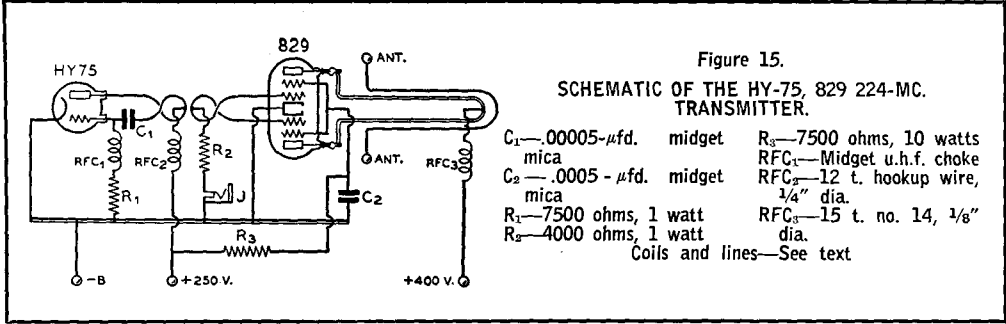

plate current of 200 ma., and the plate current may be run as high as 240 ma. if the full rating of the tube is to be used. The output at 200 ma. plate current (400 plate volts) is about 40 watts; at 240 ma. plate current it is about 50 watts.

The total length of the no. 10 bare wire tank circuit is 4 1/4" from the plate seals of the tube to the end of the hairpin. The spacing between wires is 1/8" for about 3" until the wires spread out to make soldered connection to the plate clips of the 829. The actual plate clips are small hard copper spring clips of the type supplied with HK24 tubes to make the plate connection to them. The plate line is resonated to the frequency of the oscillator by sliding the line back and forth on the tungsten rods that come out of the 829 envelope as the plate connections. The type of plate clips shown are particularly suited to this application since they slide back and forth comparatively freely on the plate lead rods.

CRYSTAL-CONTROLLED U.H.F. TRANSMITTERS

Crystal control provides the same advantages of excellent frequency stability and reliability on the u.h.f. bands that it does on the lower frequencies. However, due to the relatively greater difficulty of getting amplifier and frequency multiplier stages into operation on the higher frequency bands, crystal control is not widely used except in the case of more elaborate transmitters. High-frequency crystals have made their appearance on the market, but due to their inherent instability, high temperature coefficient, and lack of ruggedness, they have fallen into disuse, and, in fact, have been discontinued by some manufacturers. Hence, for most amateur work, the highest practical operating frequency for the crystal is 7300 kc. From this comparatively low frequency a rather large number of doublers are required to get down to the u.h.f. bands. However, through

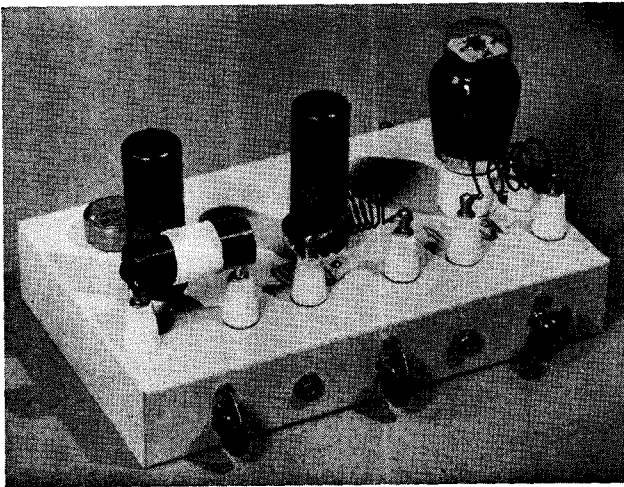

Figure 16.
THREE-STAGE 20-WATT
CRYSTAL-CONTROLLED
56-MC. EXCITER UNIT.

A 6L6 oscillator on 7 Mc. drives a 6L6G quadrupler, which in turn drives a T21 doubler to 56 Mc. Power output may be taken from any of the three stages by means of a coupling link.

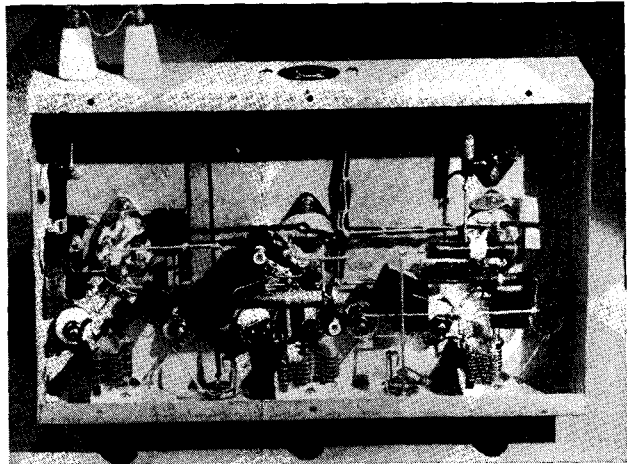

Figure 17.
UNDER-CHASSIS VIEW OF THE 56-
MC. R.F. UNIT.

the use of beam tetrodes, it is possible to obtain comparatively good operation from triplers and quadruplers, thus simplifying the frequency multiplication problem.

20-Watt Crystal Controlled 14, 28, 56 Mc. Transmitter or Exciter. The crystal controlled 56 Mc. r.f. unit illustrated in figures 16 and 17 and diagrammed in figure 18 uses conventional circuits and low cost parts. With but three stages and a 7-Mc. crystal, it supplies 20 husky watts of crystal controlled, 56-Mc. or 28-Mc. r.f. For phone operation the output stage may be modulated by a 25-watt modulator. As an exciter it has sufficient output to drive a 56-Mc. final stage to 200 watts input.

The chassis measures 12 x 7 x 2 inches. As can be seen from the photographs, the tubes are evenly spaced along the center of the chassis. Each plate coil is directly in front of the tube with which it operates. The tank condensers are mounted on the front lip of the chassis directly below their respective coils. Small jack type feed-through insulators are used to support the plug in coils and at the same time to provide connections to the condensers. Banana plugs on the coils allow quick and easy band change.

Inasmuch as each tuned circuit is on a different frequency, placing the coils in line along the front of the chassis does not have any adverse effect on the operation of the unit.

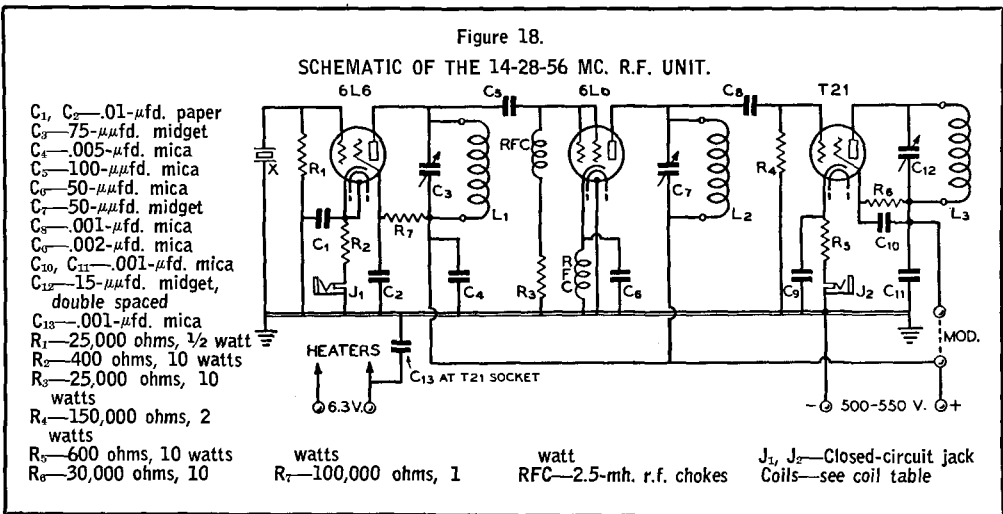

Underneath the chassis, parts are placed where convenience dictates. The T21 stage has all its ground return connections made to the feed-through insulator which is at the cold end of the plate tank. While this does not enhance the appearance of the unit, it aids in eliminating coupling in the various ground return circuits.

Two feed-through insulators at the rear of the chassis are provided for the connections from the modulator. If the unit is used as an exciter or c.w. transmitter, these terminals are simply shorted together.

The second 6L6 acts either as a doubler or quadrupler, depending upon the crystal frequency and desired T21 output frequency. Thus with a 40 meter crystal, 10 or 5 meter output is obtainable from the T21. With an 80 meter crystal, either 20 or 10 meter output is obtainable from the T21.

With the meter plugged in the cathode circuit of the T21 the total plate, screen and grid current is shown. This gives a false indication as to the plate current "dip" of the stage, which is about 15 milliamperes lower than the cathode current would indicate.

For optimum performance, the T21 stage should be loaded to approximately 90 milliamperes. At this input, the output is approximately 20 watts.

No antenna coupling circuit has been provided as the type of coupling circuit will de-

pend upon the antenna used. Any of the usual capacitive, inductive or link-coupling circuits will be suitable, however. When used as an exciter, the unit should be link coupled to the next stage.

Medium Power 56-Mc. Amplifier. By using tubes having close element spacing, yet low interelectrode capacities, and a plate tank condenser especially designed for u.h.f. service, it is possible to construct a medium power 56-Mc. amplifier that will exhibit good efficiency without resorting to the use of parallel rods in the plate circuit.

Such an amplifier is illustrated in figure 19. It utilizes a pair of HK24's in push pull, and the efficiency is as good as that obtained with commonly used equipment on the 14-Mc. band. With proper coils, the amplifier could also be used on 28 and 14 Mc., but as it was expressly designed for 56 Mc. work, the coils are not of the plug in type. By fastening the plate coil directly to the condenser stator lugs, losses are minimized.

About 20 watts excitation are required, this amount of excitation permitting approximately 175 watts input on phone or 225 watts input on c.w. The T21 exciter of figure 18 is ideally suited for use with this amplifier, the excitation being sufficient so long as the coupling link between exciter plate coil and amplifier grid coil is not too long. The losses are high at 56 Mc. in a twisted pair line, even in a good line. EO-1 cable makes the best coupling line, and it should be not more than 18 inches long unless reserve excitation is available to compensate for the losses in the line.

A conventional, resistor-biased circuit is used with circuit balance provided by a grounded-rotor grid condenser. Plate voltage is fed to the center of the plate coil through a u.h.f. choke. Since the circuit is balanced by grounding the rotor of the grid condenser, it is possible to let the rotor of the plate condenser "float," thus increasing the allowable plate voltage for a given condenser spacing. No filament by-pass condensers are used, as they were found to be unnecessary. Mechanically, the amplifier differs somewhat from the usual push-pull stage and the mechanical layout will therefore be discussed in greater detail.

Construction Details. An 11 x 7 x 2-inch chassis allows ample room for all the components except the filament transformer, which is mounted externally.

The plate condenser is one designed for u.h.f. use. The stator terminals are arranged so as to allow an extremely compact neutralizing condenser assembly. This condenser is mounted on its side with the stator terminals

COIL TABLE

All coils have small, banana type plugs spaced $2\frac{1}{2}$ in. 80 and 40 m. coils are wound on bakelite tubing; 20, 10 and 5 m. coils are self-supporting.

80 OSC.

37 turns no. 22 d.c.c. on 1 inch form.

40 OSC. OR DOUBLER

22 turns no. 22 d.c.c. on 1 inch form.

20 DOUBLER

13 turns no. 14 enam. 1 in. dia. spaced to $1\frac{1}{2}$ in.

20 FINAL

17 turns no. 14 enam. $1\frac{1}{4}$ in. dia. spaced to $1\frac{1}{2}$ in.

10 QUADRUPLER

6 turns no. 14 enam. 1 in. dia. spaced to 1 in.

10 FINAL

8 turns no. 14 enam. 1 in. dia. spaced to $1\frac{1}{4}$ in.

5 FINAL

4 turns no. 14 enam. $\frac{7}{8}$ in. dia. spaced to $1\frac{1}{4}$ in.

Note: 40 meter coil serves either as osc. coil or doubler coil.

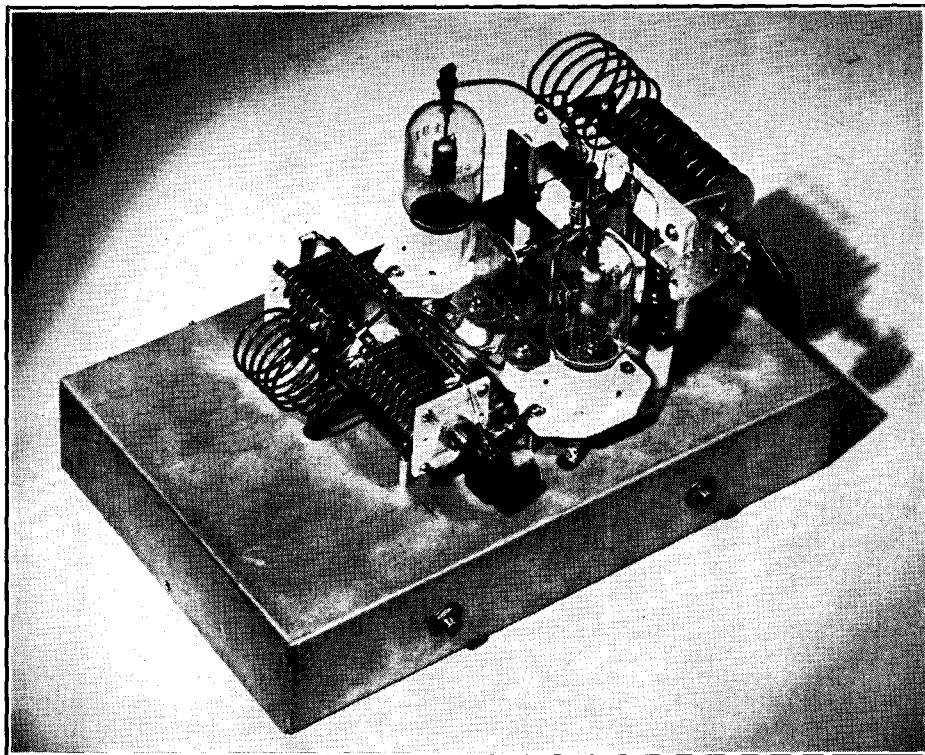

Figure 19.
125-WATT 56-MC. AMPLIFIER.

Extreme simplicity characterizes this 56-Mc. amplifier stage. The neutralizing condensers may be seen between the tubes. All components with the exception of the grid resistor are above the chassis.

toward the tubes. Two angle brackets and small standoff insulators serve to hold the condenser above the chassis. Mounting the condenser in this manner permits short plate leads to the upper stator terminals. The plate coil, 6 turns of no. 14 wire $1\frac{1}{4}$ inches in diameter, is spaced so as to mount directly on these upper terminals.

Two small discs of aluminum, 1 inch in diameter and $1/16$ inch thick, are used for the movable plates of the neutralizing condensers. Each of these plates has a flat-headed 6-32 screw through its center. The screws are held in place by nuts on the back of the discs. The heads are filed smooth with the surface of the discs. The edges of the discs are rounded with a fine-tooth file to prevent corona losses.

Two pieces of hollow rod, threaded with a 6-32 tap are mounted on the lower stator terminals of the plate condenser. The screws through the discs are screwed into these rods and neutralizing adjustments are made by

running the screws in or out of the threaded rods, thus changing the spacing between the circular plates and the stationary plates, which are simply small rectangular pieces of aluminum mounted on standoff insulators.

The grid coil is 6 turns of no. 14 enamelled wire $1\frac{1}{8}$ inches in diameter and $1\frac{1}{8}$ inches long. This condenser tunes with its plates about one-third meshed. Both ends of the rotor are grounded for the sake of symmetry.

The amplifier should not be operated for any length of time with the load removed, as the heavy r.f. field within the plate coil will heat and melt the soldered connection at its center. With the tank circuit loaded however, no trouble of this kind will be experienced.

By slightly exceeding the plate voltage rating and operating the two tubes at 1750 volts, an output of slightly over 200 watts is obtained from the amplifier at the normal plate current of 150 ma. for the two tubes. For

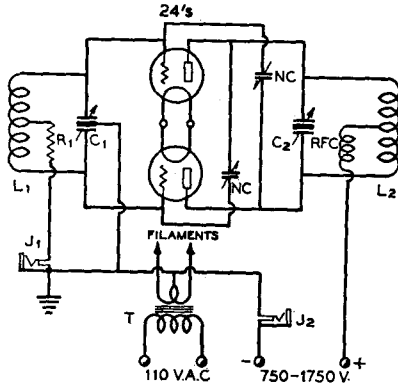

Figure 20.

125-WATT HK-24 U.H.F. AMPLIFIER

- C₁—30- μ fd. per section midget
- C₂—35- μ fd. per section, 4500-volt spacing
- R₁—3000 ohms, 10 watts
- J₁, J₂—Single closed circuit jacks
- T—Filament transformer, 6.3 v., 6 a.
- NC—See text
- L₁, L₂—See text
- RFC—U.h.f. choke

modulated operation, the plate voltage should be lowered to 1250 volts, however. Two jacks, J₁ and J₂, are provided for reading the grid and plate current. A one-turn link is used between the amplifier and the exciter and the grid current is adjusted to 50 milliamperes under load by varying the coupling.

250-Watt Linear Tank Amplifier. By cross neutralizing a push-pull linear tank u.h.f. oscillator, a highly efficient u.h.f. amplifier results. Linear tanks are advantageous in power amplifiers not for reasons of frequency stability, but to provide an inexpensive, highly efficient tank circuit having high impedance and low losses. For this reason a linear tank is ordinarily used only in the plate circuit of an amplifier, a grid coil being satisfactory for the grid tank when very high Q is not required for the sake of stability.

The 56-Mc. amplifier of figures 21 and 22 will deliver over 250 watts with good efficiency, and requires approximately 35 watts excitation. The excitation may be furnished by a stabilized push-pull HK-24 linear tank oscillator using parallel rods in the grid circuit with the grid connections made one quarter of the way up from the voltage node. Or it may be furnished by an HK-24 or HK-54 doubler tube being fed from 28-Mc. excitation either as a crystal controlled amplifier or as an amplifier for an FM transmitter.

It will be noticed that the rods not only are bent back upon themselves, but that the spacing between the two rods is not uniform. This has no detrimental effect upon the ef-

iciency of the tank, and permits a compact arrangement. The rods are of half-inch aluminum tubing, each slightly over three feet long, and bent and mounted as shown in figure 22. The position of the shorting bar is adjustable, and the tank is resonated by sliding the bar along the rods with a piece of dry wood until minimum plate current is obtained. The shorting bar is then clamped firmly by tightening the screw.

The husky, four-inch ceramic pillars which support the rods also support two of the small aluminum plates used for neutralizing.

The grid coil consists of 6 turns of no. 14 wire, 1 inch in diameter and spaced to 1 1/4 inch. The coil is soldered directly to the stator terminals of the grid condenser.

The plate choke consists of 50 turns of no. 20 d.c.e. close wound on a ceramic pillar insulator 1/2 inch in diameter. Very little r.f. voltage appears at the shorting bar, and the choke has little work to do; however it is advisable to incorporate it in order to insure proper circuit balance.

About 350 watts output may be obtained by raising the plate voltage to 1750 volts. The value of grid resistor should be increased about 50 per cent and greater excitation power will be required. At this plate voltage it is necessary to keep the tubes loaded evenly and the tank circuit in exact resonance. If the higher value of plate voltage is used, it is advisable first to tune up at reduced voltage.

FREQUENCY MODULATION TRANSMITTERS

Frequency modulation or FM transmission is destined to be one of the major uses of the ultra-high frequency bands. The u.h.f. bands are wide enough so that the wide band of frequencies required for FM are amply contained. In addition, a practically infinitesimal amount of modulating power is required to modulate an FM transmitter, regardless of its power output, and, a last advantage, frequency multipliers, or class C or class B amplifiers may carry FM r.f. since the amplitude of an FM signal is constant. However, a complete explanation of the theory and practice of FM has been given in *Chapter Nine*, so this section will be devoted entirely to the description of equipment designed for FM transmission.

FM transmission is permissible on all amateur frequencies above 58,500 kc.; that is, it is permitted from 58.5 to 60 Mc., 112 to 116 Mc., 224 to 230 Mc., and above 300 Mc. The equipment to be described is designed for operation on the 112-Mc. band, but it can just as

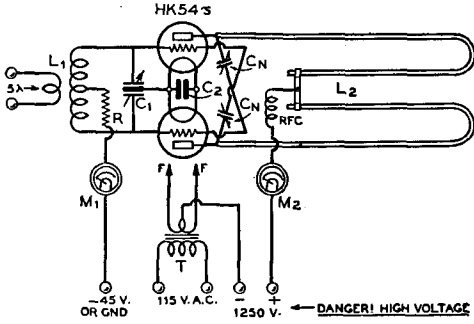

Figure 21.
SCHEMATIC OF HK-54 LINEAR TANK AMPLIFIER.

- C₁—30- μ fd. per section, no fixed bias; 2000 ohms double-spaced midget if 45 v. fixed bias.
- C₂—.002- μ fd. mica
- L₁, L₂—See text
- R—3000 ohms, 25 watts if
- M₁—0-100 ma. d.c.
- M₂—0-500 ma. d.c.
- T—5 v. 10 amp. fil. trans.

easily be operated on any other frequency assigned to FM transmission simply by changing the frequency of operation of the various frequency multipliers and then using a final amplifier on the desired band.

75-Watt 112-Mc. FM Transmitter

This transmitter consists of two units, exclusive of power supplies, the exciter which ends up in a HK-24 doubler to 38 Mc., and the final stage which uses a pair of HK-54's as a push-pull tripler to 114 Mc.

Exciter Lineup. The use of a power push-pull tripler as the output stage of the transmitter required that the exciter end up with a stage operating on 38 Mc. for an output frequency of 114 Mc. There are a large number of oscillator frequencies which in conjunction with various combinations with doublers, triplers, or quadruplers will yield the desired output frequency. However, since it was desired to use an HK-24 as a doubler in the output stage of the exciter and thus do away with neutralizing worries, the excitation requirements seemed to call for two doubler stages between the oscillator and the exciter output stage.

The original design of the exciter called for 6L6's in the doubler stages. The 6L6's looked all out of proportion driving the diminutive HK-24, however, so 6F6's were substituted to "see what would happen." Nothing happened except that the tube cost went down considerably—the output as indicated by the grid current to the HK-24 remained the same.

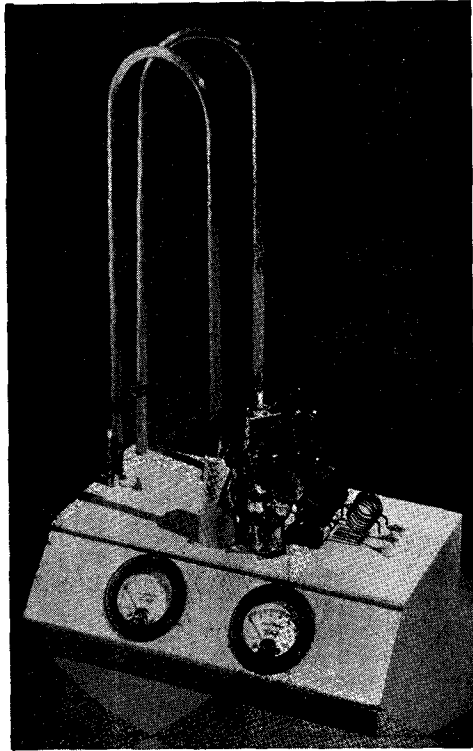

Figure 22.
FOLDED LINEAR TANK 56-MC. 250-WATT AMPLIFIER.

An inexpensive yet compact and highly efficient tank circuit for this HK54 amplifier is had by folding back on itself a quarter-wave stub made of half-inch aluminum tubing.

The Frequency Modulated Oscillator.

The oscillator is also a 6F6. It is arranged as a conventional e.c.o. with impedance coupling to the following stage. Omitted from the diagram is a 25,000-ohm, 2-watt series dropping resistor to the oscillator screen. The output obtained across the plate r.f. choke is not great, but it is sufficient to excite the following doubler to full output. A moderate amount of capacity across the oscillator tank coil is provided by a 75- μ fd. midget variable in parallel with a 100- μ fd. zero temperature coefficient ceramic condenser. With the coil specified in the diagram caption the capacity required to hit 4750 kc. in the oscillator is about 160 μ fd., 100 μ fd. of this being supplied by the fixed condenser, of course.

The two doubler stages following the oscillator are quite conventional. The two stages are identical with the exception of tank

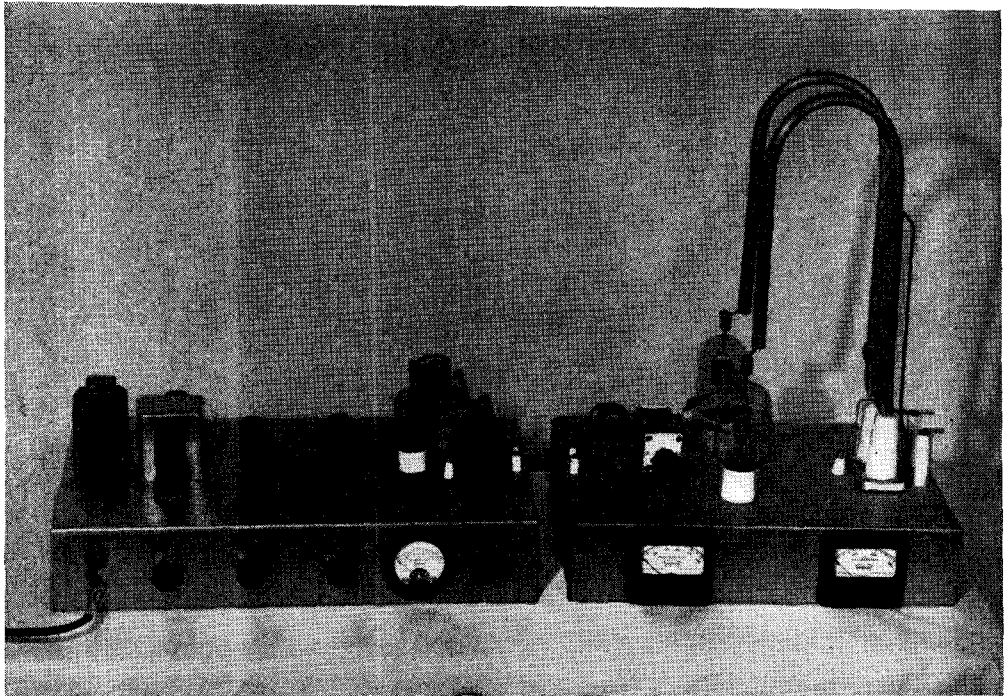

Figure 23.

THE 75-WATT 112-MC. F.M. TRANSMITTER.

The transmitter proper is constructed on two chassis. The exciter unit on the left puts out frequency modulated r.f. at 38 Mc. which is tripled to 114 Mc. by the push-pull 54 output stage at the right.

circuits and grid leaks. R_0 , the grid leak for the first stage is a 100,000-ohm 1-watt unit while R_{10} in the second stage has been made a 150,000-ohm 2-watt resistor to allow for the increased excitation available at this point. Cathode bias is also used on both stages to provide a measure of safety in case the excitation should inadvertently be removed. A common series screen resistor R_{16} is used on both 6F6 doubler stages. A point leading to smooth, "bug-free" operation of these doubler stages is the use of the no. 1 terminal on the sockets as the ground point of the by-passes associated with each stage. The plate blocking, screen by-pass, and cathode by-pass condensers for each stage are grounded through the shortest possible lead to this point. The use of .003- μ f.d. "postage-stamp" mica condenser permits the length of the leads to be kept to a minimum.

The HK-24 exciter output doubler to 38 Mc. is also conventional. Here again care has been taken to bring the r.f. ground returns to a common point on the tube socket. A lug under one of the socket mounting screws serves as the ground point in this case.

The Speech System. Every effort has been taken to reduce hum modulation in the transmitter shown. The amount of undesirable modulation taking place is directly related to the amount of impedance in the reactance-tube grid return circuit, since the grid will pick up hum in proportion to its impedance to ground. Shorting this grid return to ground (across C_5) should give a "p.d.c." note if the reactance tube is operating properly. The grid impedance to ground has been kept to a minimum through the use of a 500-ohm output transformer at T_2 . With a crystal microphone the cascaded 6N7 speech amplifier will provide a peak undistorted audio output of 25 volts across the 500-ohm winding. This amount of voltage is sufficient to operate the modulator over the complete linear portion of its characteristic. Any amount of swing desired up to the full 800 kc. of which the rig is capable may be had by adjusting the speech gain control, R_{22} .

The Push-Pull Tripler Final. Due to the difficulty in obtaining a short, direct ground return in single-ended stages, push-pull frequency multipliers are almost universally

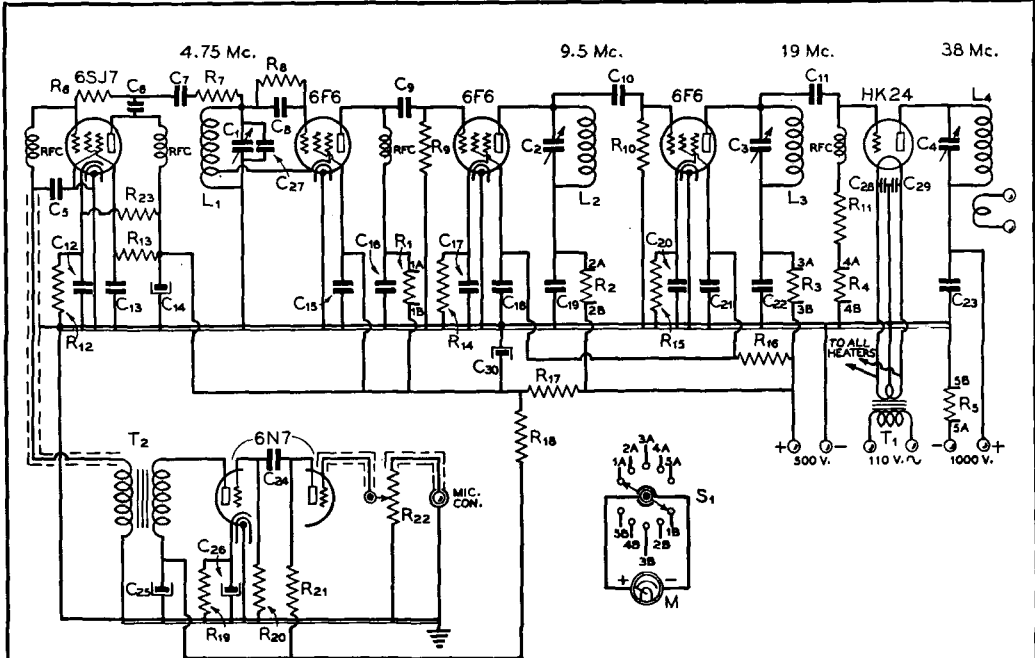

Figure 24.

WIRING DIAGRAM OF THE F.M. EXCITER.

- | | | | |
|---|---|--|--|
| C ₁ —75- μ fd. midget variable | C ₂₄ —.02- μ fd. 400 volt tubular | watts | S ₁ —Two section, 5 position "Ham-switch" |
| C ₂ —35- μ fd. midget variable | C ₂₅ —8- μ fd. 450 volt electrolytic | R ₁₂ —1000 ohms, 1 watt | T ₁ —6.3 volts, 10 amps. |
| C ₃ —25- μ fd. midget variable | C ₂₆ —10- μ fd. 25 volt electrolytic | R ₁₃ —50,000 ohms, 1 watt | T ₂ —Triode plate to 500-ohm line |
| C ₄ —20- μ fd. variable, .070" spacing | C ₂₇ —100- μ fd. zero temperature coefficient ceramic | R ₁₄ , R ₁₅ —500 ohms, 10 watts | RFC—2 1/2 mh. |
| C ₅ , C ₆ , C ₇ —.003 μ fd. mica | C ₂₈ , C ₂₉ —.003 - μ fd. mica | R ₁₆ —15,000 ohms, 10 watts | M—0-150 ma. |
| C ₈ —.0001- μ fd. mica | R ₁ , R ₂ , R ₃ , R ₄ , R ₆ —50 ohms, 1 watt | R ₁₇ —5000 ohms, 20 watts | L ₁ —17 turns of no. 22 d.c.c. wound to a length of 7/8 inch on 1 1/4" dia. form. |
| C ₉ —.0001- μ fd. mica | R ₅ —100,000 ohms, 1/2 watt | R ₁₈ —10,000 ohms, 1 watt | Cathode tap 6 turns from ground end. |
| C ₁₀ , C ₁₁ —.00005 - μ fd. mica | R ₇ —2500 ohms, 1 watt | R ₁₉ —2000 ohms, 1/2 watt | L ₂ —20 turns no. 14 enam. 1" dia., 1 5/8" long |
| C ₁₂ —.01- μ fd. 400 volt tubular | R ₈ —60,000 ohms, 1 watt | R ₂₀ , R ₂₁ —50,000 ohms, 1/2 watt | L ₃ —15 turns no. 14 enam. 3/4" dia. 1-3/8" long |
| C ₁₃ —.003- μ fd. mica | R ₉ —100,000 ohms, 1 watt | R ₂₂ —1 megohm potentiometer | L ₄ —10 turns no. 10 enam. 1" dia., 2 1/2" long |
| C ₁₄ —8- μ fd. 450 volt electrolytic | R ₁₀ —150,000 ohms, 2 watts | R ₂₃ —50,000 ohms, 1/2 watt | |
| C ₁₅ , C ₁₆ , C ₁₇ , C ₁₈ , C ₁₉ , C ₂₀ , C ₂₁ , C ₂₂ —.003- μ fd. mica | R ₁₁ —25,000 ohms, 10 watts | | |
| C ₂₃ —.002- μ fd. 2500 volt mica | | Note: for oscillator screen resistor, see text. | |

used in u.h.f. equipment above 60 Mc. The push-pull arrangement is inherently balanced to ground so that no r.f. current flows in the external plate-to-ground circuit. Even harmonics cancel out in the push-pull output circuit but it is possible to obtain fair efficiency (considering the frequency) at the third harmonic.

The tripler stage grid circuit is arranged for link coupling to the exciter output tank.

The split-stator grid condenser, C, (figure 25) has its rotor grounded to aid in establishing circuit balance. The ground connection does not need to be particularly short as the balance between the two tubes is so close that a very slight amount of r.f. current flows in the lead. Grounding the rotor to the most convenient point on the chassis will serve the purpose. The parallel-rod plate tank used is the best and least expensive way of ob-

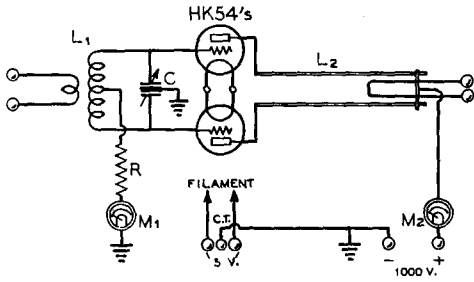

Figure 25.
SCHEMATIC OF THE PUSH-PULL TRIPLER TO 114 MC.

- C—50- μ fd. per section, midjet
- R—20,000 ohms, 20 watts
- L₁—8 turns no 14 enam. 1" dia., 1 $\frac{1}{4}$ " long
- L₂—Linear plate tank, see text
- M₁—0-100 ma.
- M₂—0-300 ma.

taining good tank circuit efficiencies at 114 Mc.

Meters are provided in the plate and grid circuit of the output stage so that an accurate check on the operation may be kept at all times. There is no need to place the plate

meter in the negative lead to this stage since the large exposed plate tank should be sufficient warning to the operator to keep his hands a safe distance from the stage at all times.

Tuning Procedure. If an accurately calibrated receiver which tunes to 4750 kc. is available, no difficulty should be experienced in getting the transmitter tuned up. The oscillator is simply set to this frequency and the following doubler stages in the exciter tuned to resonance with the tripler output stage disconnected. Exciter meter readings should be about as follows: oscillator plate, 30 ma.; 9.5-Mc. doubler plate, 28 ma.; 19-Mc. doubler plate, 28 ma.; HK-24 grid, 12 ma.; HK-24 plate unloaded, 20 ma.; HK-24 plate loaded, 75 ma. These figures are for 500 and 1000 volt power supplies.

When the transmitter as a whole is being tuned up for the first time it is best to apply about 500 volts to all stages until one becomes familiar with the transmitter's operation. The correct coupling to the output stage grid is about as shown in the photograph of the complete transmitter; the link coil should be pushed about two-thirds of the way into the HK-54 grid coil for maxi-

Figure 26.
UNDER-CHASSIS VIEW OF THE EXCITER.

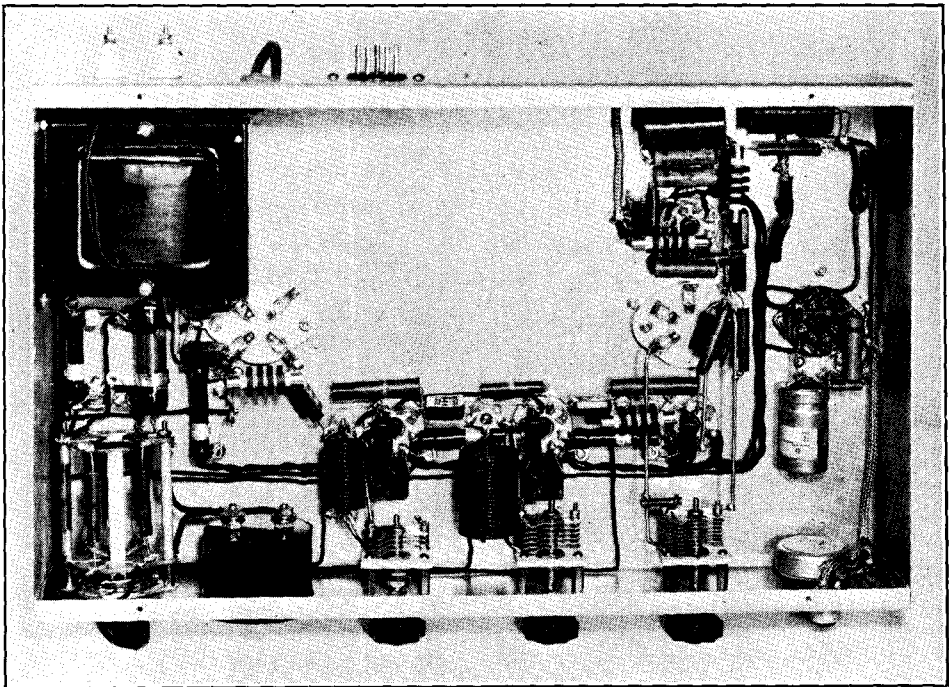

imum power transfer. With the lowered voltage applied to the transmitter and the tripler grid circuit tuned to resonance and the shorting bar on the plate rods down against the standoff insulators, a screwdriver with a *well insulated* handle may be used to determine the resonant point on the plate rods. The screwdriver should be pressed firmly against both rods and slid along from the power supply end toward the plates. Resonance will be indicated by a sharp drop in plate current as the screwdriver passes over the proper point. This point will probably be from one to three inches up the rods from the power supply end. If resonance is not found until the screwdriver is to within 6 or 8 inches of the plate ends of the rods it is an indication that the rods are too short, as the resonance point 6 or 8 inches away from the plates is that for the fifth harmonic of the grid frequency, or 190 Mc.

When resonance has been found by the screwdriver, the shorting bar should be placed at this position and tightly clamped to the rods. The shorting bar may be moved back and forth a short distance in either direction to insure that the resonance point has been correctly determined, making sure to remove the plate voltage each time the shorting bar is touched.

Final Operating Conditions. After the shorting bar has been properly located full plate voltage may be applied to the transmit-

ter and the currents in the tripler stage checked. These should be: grid current—25 ma.; plate current unloaded—125 ma. A 75-watt lamp bulb connected across the antenna terminals should glow at about normal brilliancy when the coupling hairpin is adjusted so that the transmitter is loaded to 225 milliamperes. This indicates that the tripler efficiency is approximately 30 per cent, which is about normal at these frequencies. The 150-watt difference between input and output would seem to indicate that the plate dissipation of the tubes was being considerably exceeded. However, the criterion in matters such as this is the plate temperature of the tubes, and their color does not seem to indicate that their 50-watt plate dissipation is being exceeded. Undoubtedly the 50-watt discrepancy between the total power loss and the plate dissipation can be accounted for in radiation and resistance losses in the plate tank.

50-Watt FM Transmitter

The transmitter illustrated in figures 27 and 28 and diagrammed in figure 29 has an output of 50 watts, frequency modulated, at 112 Mc. Except for the 500-volt, 250-ma. power supply, the transmitter is all located on the single 10" by 23" by 3" chassis.

The Exciter Stages. The exciter section of the transmitter, which includes those stages

Figure 27.

TOP VIEW OF THE 50-WATT F.M. TRANSMITTER.

The three tubes in the row on the left edge of the chassis are, front to back: the 6F6 oscillator, 6SJ7 reactance tube, and 6SC7 speech amplifier. Then comes the 6V6-GT doubler to 38 Mc. and the push-pull 7A4 tripler to 112 Mc., followed by the 50-watt output tube and its tank circuit. Note the manner in which the plate circuit tubing condenser has been soldered to the plate rods.

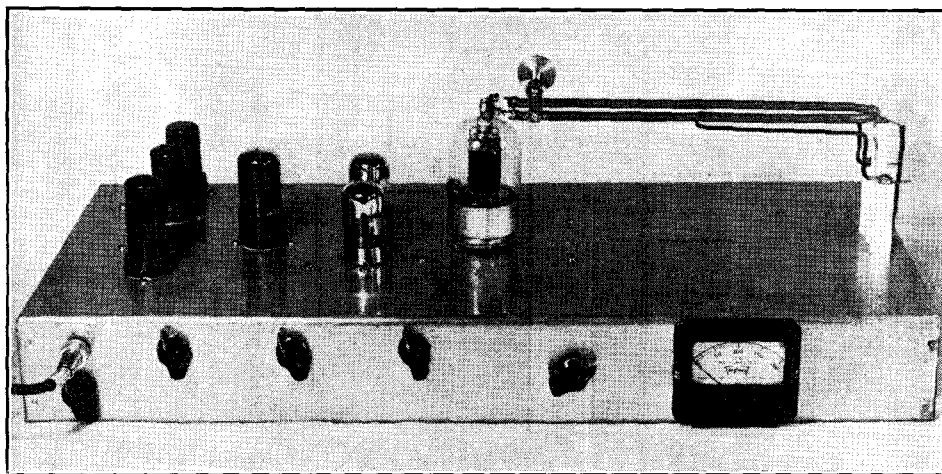

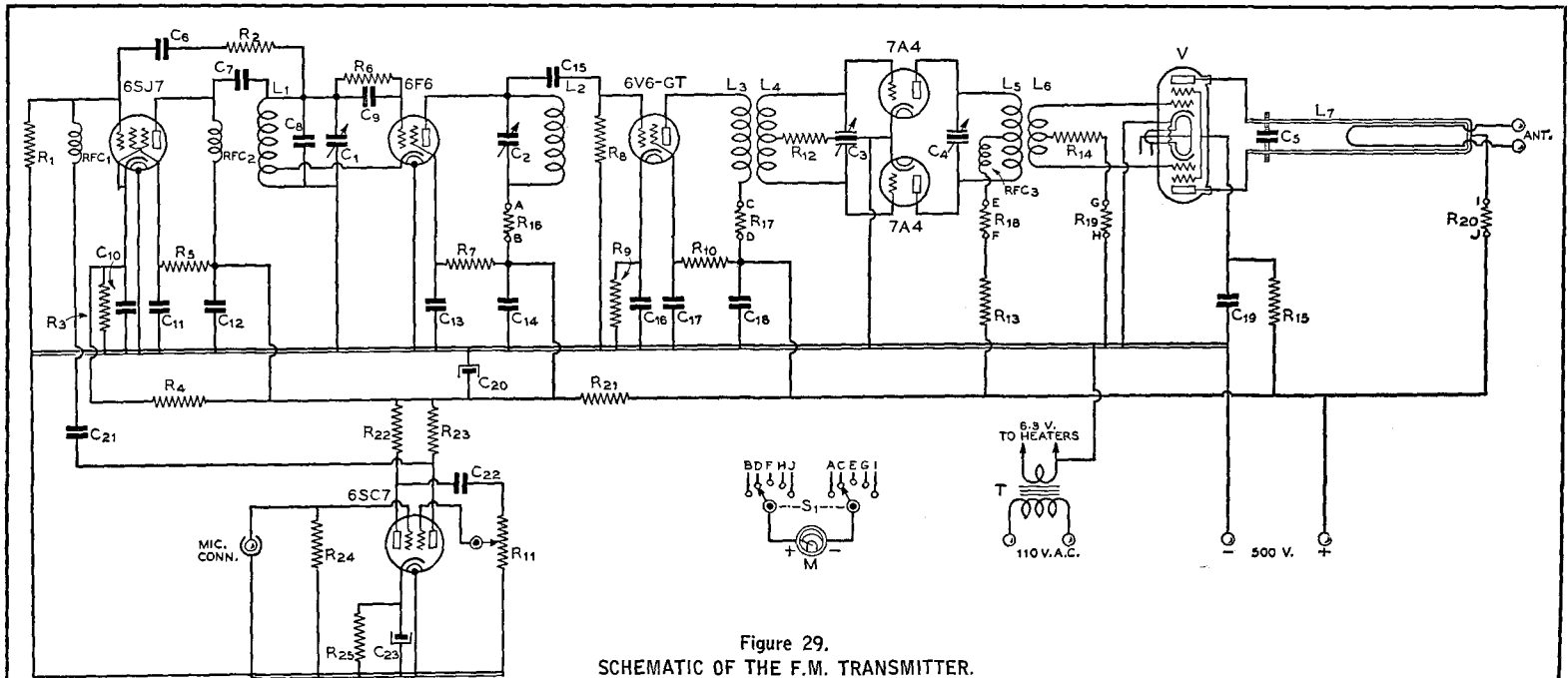

Figure 29.

SCHMATIC OF THE F.M. TRANSMITTER.

C₁, C₂—50- μ fd. midget variable
 C₃—50- μ fd. per section
 C₄—25- μ fd. per section
 C₅—Midget circular plate neut. condenser mounted on plate rods
 C₆, C₇—0.03- μ fd. midget mica
 C₈—0.001- μ fd. zero coeff.
 C₉—0.001- μ fd. midget mica

C₁₀, C₁₁, C₁₂—0.03- μ fd. mica
 C₁₃, C₁₄—0.03 - μ fd. mica
 C₁₅—0.0005- μ fd. mica
 C₁₆, C₁₇, C₁₈—0.003- μ fd. mica
 C₁₉—0.003- μ fd. silver mica
 C₂₀—8- μ fd. 450-volt elect.
 C₂₁—0.1- μ fd. 400-volt tubular
 C₂₂—0.05- μ fd. mica
 C₂₃—10- μ fd. 25 - volt elect.

R₁—500,000 ohms, 1/2 watt
 R₂—50,000 ohms, 1/2 watt
 R₃—1000 ohms, 1/2 watt
 R₄—60,000 ohms, 1 watt
 R₅—100,000 ohms, 1/2 watt
 R₆—50,000 ohms, 1/2 watt
 R₇—25,000 ohms, 1 watt
 R₈—100,000 ohms, 1 watt
 R₉—600 ohms, 10

watts
 R₁₀—25,000 ohms, 1 1/2 watts
 R₁₁—500,000 - ohm potentiometer
 R₁₂—10,000 ohms, 1 1/2 watts
 R₁₃—5000 ohms, 10 watts
 R₁₄—10,000 ohms, 1 1/2 watts
 R₁₅—25,000 ohms, 1 1/2 watts
 R₁₆, R₁₇, R₁₈, R₁₉, R₂₀—100 ohms, 1 watt
 R₂₁—5000 ohms, 10 watts

R₂₂, R₂₃—250,000 ohms, 1/2 watt
 R₂₄—1 megohm, 1/2 watt
 R₂₅—1000 ohms, 1/2 watt
 RFC₁, RFC₂—2.5 mh. 125 ma.
 RFC₃—U.h.f. choke
 T—6.3-volt 10- ampere trans.
 M—0-200 d.c. milli-ammeter
 L₁—12 t. no. 18 d.c.c. 1" dia. 1" long
 L₂—13 t. no. 14 enam., 5/8" dia. 1" long

L₃—8 turns hookup wire inside L₄
 L₄—8 turns no. 14 enam. 7/8" dia. 1 1/4" long
 L₅—4 t. no. 14 enam. 5/8" dia. 3/4" long
 L₆—2 turns hookup wire wound with L₅
 L₇—20" 1/4" copper tubing bent into a hairpin with 1" center - to - center spacing
 V—815 dual beam tetrode

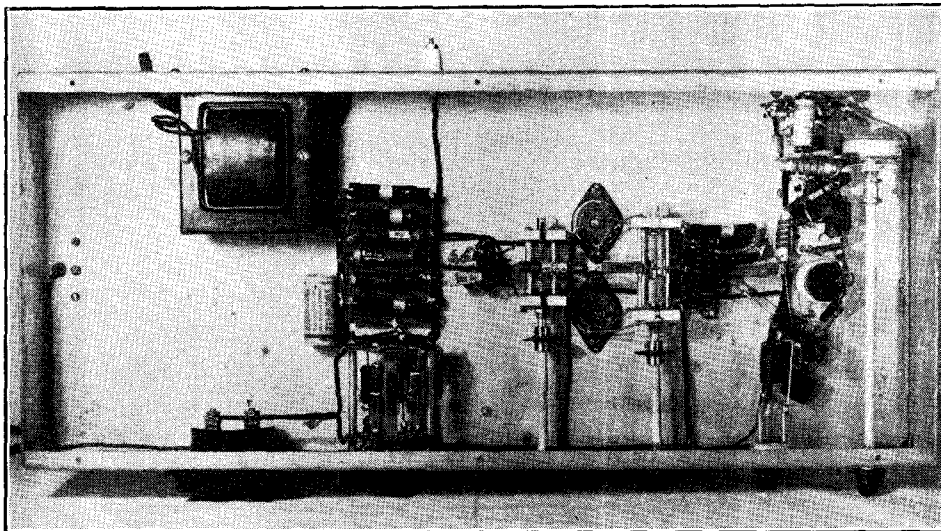

Figure 28.

UNDER-CHASSIS VIEW OF THE 50-WATT F.M. TRANSMITTER.

The filament transformer for the entire rig is shown in the left rear. The meter switch is mounted, with the resistors between its sections, directly in front of the resistor tie plate for the rig.

preceding the output stage, employs standard receiving tubes throughout and is distinguished by the lack of unusual or "trick" circuit arrangements. The frequency modulated oscillator is a 6F6 operating at low plate and screen voltages to assure minimum frequency drift. The grid circuit of this stage is tuned to 9.5 Mc., and the plate circuit to the second harmonic, or 19 Mc.

Excitation from the oscillator stage is carried through a small coupling condenser to the grid of the following doubler, which is a 6V6-GT. To reduce the number of tuned circuits in the transmitter, the plate circuit of the doubler stage is tuned only by being closely inductively coupled to the grid circuit of the following stage. The close coupling required for proper operation of this type of circuit is achieved by locating the 6V6-GT plate coil, L_3 , inside the following grid coil, L_4 . There are no rigorous requirements in the choice of the tube used in the doubler stage, and a 6V6 or 6L6 may be substituted for the 6V6-GT, if desired, without making any circuit changes. If the plate voltage to the doubler stage is lowered somewhat, a 6F6 may be used. The doubler output frequency is 38 Mc.

Following the doubler stage is a tripler to 114 Mc. employing push-pull 7A4's. Circuit balance in this stage is provided by grounding the rotor of the split stator grid condenser. It is not necessary to ground the

rotor of the plate tank condenser in this stage. No harm will be done, however, if the type of plate condenser used makes grounding the rotor more convenient than insulating it.

Tests with an experimental version of this transmitter showed the necessity of placing the tuned input circuit of the tripler directly in the grid circuit, rather than the more conventional method of capacity coupling from a balanced, tuned plate circuit in the preceding stage. With the latter type of circuit the tripler stage is prone to oscillate while with the circuit shown in the diagram there is no tendency toward oscillation or instability.

By itself, the exciter section of the transmitter forms a complete, inexpensive, low power 112-Mc. transmitter with an output of 5 to 7 watts, and if the constructor is interested in a transmitter in this power class he could well choose the exciter of the 50-watt transmitter.

Output Stage. The 50-watt output stage utilizes an 815 tube, which has two beam tetrodes, each of somewhat lower power rating than an 807, in a single envelope. Excitation to the 815 is obtained by a two-turn coupling coil pushed between the center turns of L_5 . The excitation is adjusted by pushing the coupling coil in and out of L_5 —too much coupling will overload the tripler and reduce the excitation and output in the final amplifier, while too little coupling will reduce the excitation and output. It is a simple matter

to adjust the excitation properly by observing the output from the transmitter.

The final plate tank circuit consists of a U-shaped piece of $\frac{1}{4}$ -inch copper tubing measuring $9\frac{1}{2}$ inches on each leg, with the two legs separated 1 inch. Tuning of the linear tank circuit is accomplished by varying the spacing between the plates of a small condenser at the plate ends of the tank circuit. The condenser plates and their supporting strips were taken from a small neutralizing condenser originally intended for neutralizing a 6L6. The plates and the supporting metal were removed from the insulator assembly which originally served as a mounting for the condenser and the metal strips were soldered to the tank circuit with the aid of a small alcohol torch.

The antenna coupling "hairpin" is made up of a length of no. 10 enamelled wire supported by two standoff insulators which also serve as terminals for connecting the antenna feeders. The antenna coupling is varied by bending the coupling hairpin toward or away from the plate tank.

Modulator and Speech Amplifier. The frequency modulator uses a conventional reactance tube circuit. The theory of operation of this type of circuit is described in Chapter 9. Partially fixed bias on the reactance tube is provided by resistor R_4 , which bleeds a constant amount of current through the reactance tube bias resistor, R_3 . Varying amounts of positive and negative d.c. voltage may be applied across the grid resistor, R_1 , to determine whether the frequency varies linearly each side of the "carrier" frequency when the control voltage is varied. Non-linearity may be corrected by changing the value of R_4 . In the transmitter shown, the resistor value specified in the diagram caption gave a linear voltage-frequency characteristic. For a 50-ke. swing under modulation at 112 Mc. the modulator should be linear over a range of slightly more than 4 ke. at the oscillator frequency.

A single 6SC7 dual triode is used as a two-stage speech amplifier. This tube provides considerably more voltage gain than is necessary to give a 50-ke. swing, when a crystal microphone is used. The 6SC7 may be replaced by a low gain triode (6C5, 6J5, etc.) if a low output single-button microphone or a double-button microphone is used. High output single-button microphones (telephone type) may be coupled directly into the reactance tube control grid by a microphone transformer, with the gain control, R_{11} , replacing the fixed grid resistor R_1 .

Construction. As the photographs show, all of the wiring except the 815 plate cir-

cuit is below the chassis. The oscillator, modulator and speech amplifier circuit occupy the space toward the left edge of the chassis. The stages following the oscillator are placed along the center line of the chassis, with each circuit placed as close to the preceding one as possible, since short leads are of prime importance in the high and ultra-high-frequency stages. In each of the stages following the oscillator, all ground returns are brought, through separate leads, to a single point on the tube socket.

Operation. To place the transmitter into operation, 250 to 300 volts should be applied to the "+500" terminal and the oscillator first tuned to 9500 kc., as indicated by a conventional receiver. After the oscillator grid circuit has been set to the correct frequency, the oscillator plate circuit and following stages should each be tuned to resonance as indicated by minimum plate current. It will be found that tuning the oscillator plate circuit to the second harmonic of the grid circuit frequency will change the oscillator frequency slightly, and it may be necessary to retune the grid circuit after the plate circuit has been resonated. After the complete transmitter has been tuned up, the antenna may be connected and the full 500 volts applied.

Typical current readings, at resonance, are as follows: Oscillator plate—15 ma.; doubler plate—35 ma.; tripler plate—40 ma.; final amplifier grid—3 ma.; final amplifier plate—150 ma.

Although it is not to be recommended except for extremely short periods of time, a check on the operation of the output stage may be made by removing the loading and observing the minimum plate current. If the stage is operating correctly the plate current will be approximately 30 ma. at resonance without load.

MICROWAVE TRANSMITTERS

Microwaves are generally considered as being those whose wavelength is less than one meter (frequencies greater than 300 Mc.). Microwaves are generated by means of *magnetrons*, *electron-orbit oscillators* and *regenerative oscillators*. Microwaves are used by broadcast stations for remote pickup, by amateurs and experimenters and for occasional telegraph and telephone communication such as the British channel-spanning system. The technical problems encountered in this field are numerous, yet new tubes designed for microwaves have simplified many of these problems and have been instrumental in increasing the usefulness of the band.

Figure 30.
SPLIT-ANODE MAGNETRON
MICRO WAVE OSCILLATOR.

Special magnetron tubes delivering several watts output at extremely high frequencies are available for certain experimental purposes. Their main disadvantage for amateur work is that they are rather difficult to obtain. Also, a source of d.c. of large magnitude is required for the field electromagnet.

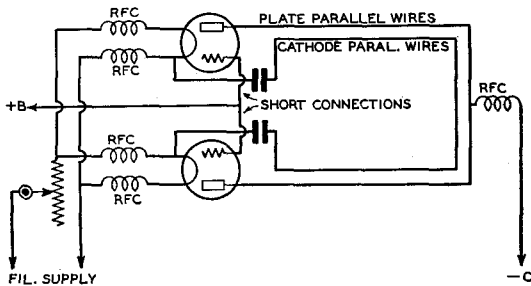
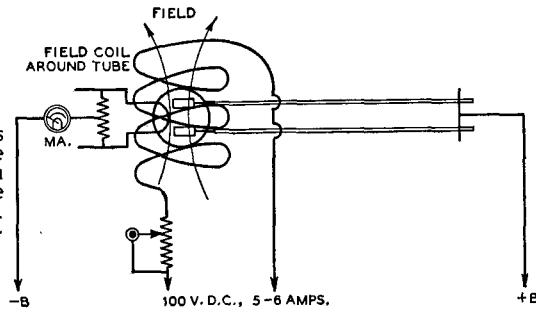

Figure 31.
KOZANOWSKI OSCILLATOR.

This type of u.h.f. oscillator requires the use of tubes having cylindrical elements, such as the HK-24 and 54, 35TG and 75T, 1628 and 852, and HY-75. Certain receiving tubes such as the 7A4, 955, etc. may also be used for lower power outputs. The grid dissipation of the tubes is the most important limiting factor on their power output.

The Magnetron Oscillator. The magnetron is a specially designed tube for very-short-wave operation. It consists of a filament or cathode between a split plate, as shown in figure 30.

A magnetic field is produced at the filament by means of a large external field coil which is energized by several hundred watts of d.c. power. Ultra-high-frequency oscillations are produced in the split plate circuit when this magnetic field is in the correct direction and of the proper intensity. A parallel-wire tuned circuit should be used for wavelengths below one meter. The frequency stability is not very good and it is difficult to obtain satisfactory voice modulation from magnetron oscillators.

Electron Orbit Oscillator. The range of oscillation in ordinary circuits is limited by time required for electrons to travel from cathode to anode. This transit time is negligible at low frequencies, but becomes an important factor below 5 meters. With ordinary tubes, oscillation cannot be secured below 1 meter, but by means of *electron orbit oscillators*, in which the grid is made positive and the plate is kept at zero or slightly negative potential, oscillation can be obtained on wavelengths very much below 1 meter.

Parallel-wire tuning circuits can be connected to these tube oscillators in order to in-

crease the power output and efficiency. The tubes most suitable for this type of operation have cylindrical plates and grids, and their output is limited by the amount of power which can be dissipated by the grids. For transmitting, tubes such as the 35T, HK54, 852, etc., can be used in the circuit shown in figure 31, which is a modification of the circuit of figure 32. More output is obtained by using a tuned-cathode circuit instead of tuned-grid circuit. Modulation can be applied to either the plate or grid. The frequency stability is very poor.

Regenerative Oscillators. The introduction of RCA "Acorn" tubes made low power $\frac{1}{2}$ -meter regenerative oscillators practical. These tubes are more efficient than ordinary types for ultra-high-frequency work, and are available in several types in both 6.3 v. and 1.4 v. series. They are satisfactory for low-power transmitters and superregenerative receivers. The regenerative circuits are quite similar to those for longer wavelengths, except for the physical size of condensers and coils. The tube element spacing in these acorn tubes is made so small that electron transit time becomes a negligible factor for wavelengths above 0.6 meter.

Acorn tubes are also made in r.f. pentode amplifier types, both sharp cutoff and remote cutoff. However, these require concentric

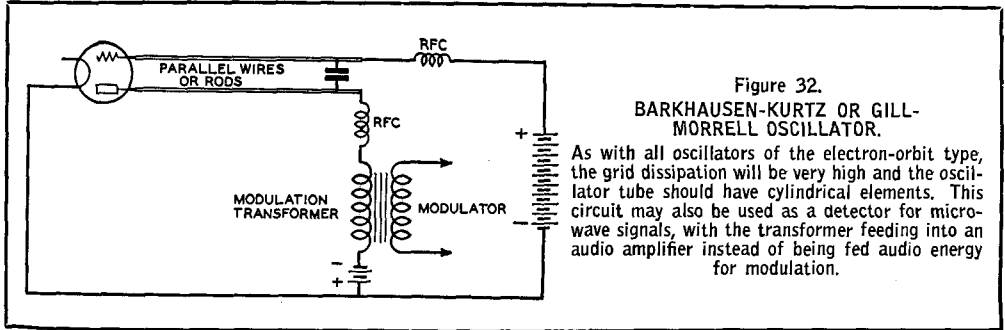

Figure 32.
BARKHAUSEN-KURTZ OR GILL-MORRELL OSCILLATOR.

As with all oscillators of the electron-orbit type, the grid dissipation will be very high and the oscillator tube should have cylindrical elements. This circuit may also be used as a detector for microwave signals, with the transformer feeding into an audio amplifier instead of being fed audio energy for modulation.

tank circuits below $2\frac{1}{2}$ meters because at such high frequencies it is impossible, due to high losses, to obtain appreciable gain (high Q) with conventional tanks.

For higher power oscillators, special transmitting tubes designed for microwave work are offered by several manufacturers, notably Western Electric, Hytron, RCA, and Eimac. The HK24 also makes an excellent microwave tube when two are used in push-pull.

For maximum output at $2\frac{1}{2}$ meters and shorter wavelengths, filament chokes are sometimes required. One way to avoid the necessity for filament chokes and at the same time increase the efficiency is to substitute a tuned filament circuit for the usual tuned grid circuit, by-passing the grids to ground.

Microwave regenerative oscillators are most efficient when linear tank circuits are used in place of coils, and when two tubes are used

in push-pull. Maximum output and efficiency cannot be obtained with single-ended circuits.

$\frac{3}{4}$ -Meter Parallel Rod WE-316A Transmitter. A large variety of circuits could be suggested for microwave operation, but the most simple of these is the one shown in figures 33 and 34. It consists of two parallel half-wave rods, spaced about $\frac{1}{4}$ -inch apart, to provide a $\frac{3}{4}$ -meter tuned circuit of fairly-high Q . The grid and plate of the tube are connected to the copper rods; this capacity causes the physical length to be less than a half wavelength. As can be seen from the photograph, the plate r.f. choke and the grid leak do not connect to the center of the rods, but rather across the voltage node. The distance between this point and the free ends of the rods is a quarter wavelength.

Filament r.f. chokes, or tuned filament leads, are desirable for operation below one

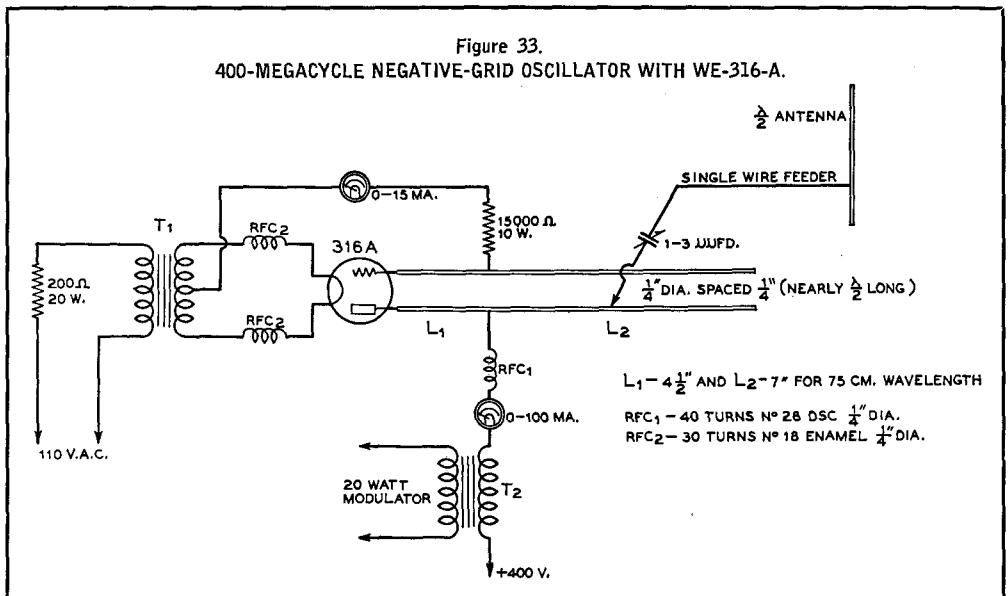
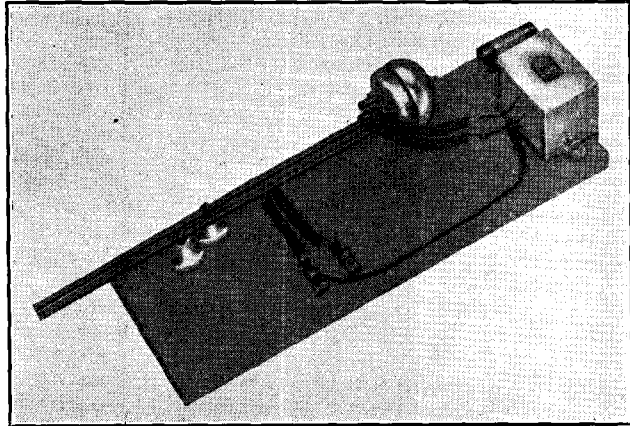

Figure 33.
400-MEGACYCLE NEGATIVE-GRID OSCILLATOR WITH WE-316-A.

$L_1 - 4\frac{1}{2}''$ AND $L_2 - 7''$ FOR 75 CM. WAVELENGTH
RFC₁ - 40 TURNS NO 28 DSC $\frac{1}{4}''$ DIA.
RFC₂ - 30 TURNS NO 18 ENAMEL $\frac{1}{4}''$ DIA.

Figure 34.
WE-316A 400-MEGACYCLE
OSCILLATOR.



meter because the filament is not strictly at a point of ground potential in the oscillating circuit. These filament chokes consist of 30 turns of no. 16 enamelled wire, wound on a 1/4-inch rod, then removed from the rod and air-supported, as the picture shows. The

length of these chokes is approximately 3 inches. A 200-ohm resistor is placed in series with the 110-volt a.c. line to the filament transformer in order to reduce the transformer secondary voltage from 2 1/2 to 2 volts, because the filament of the tube operates on

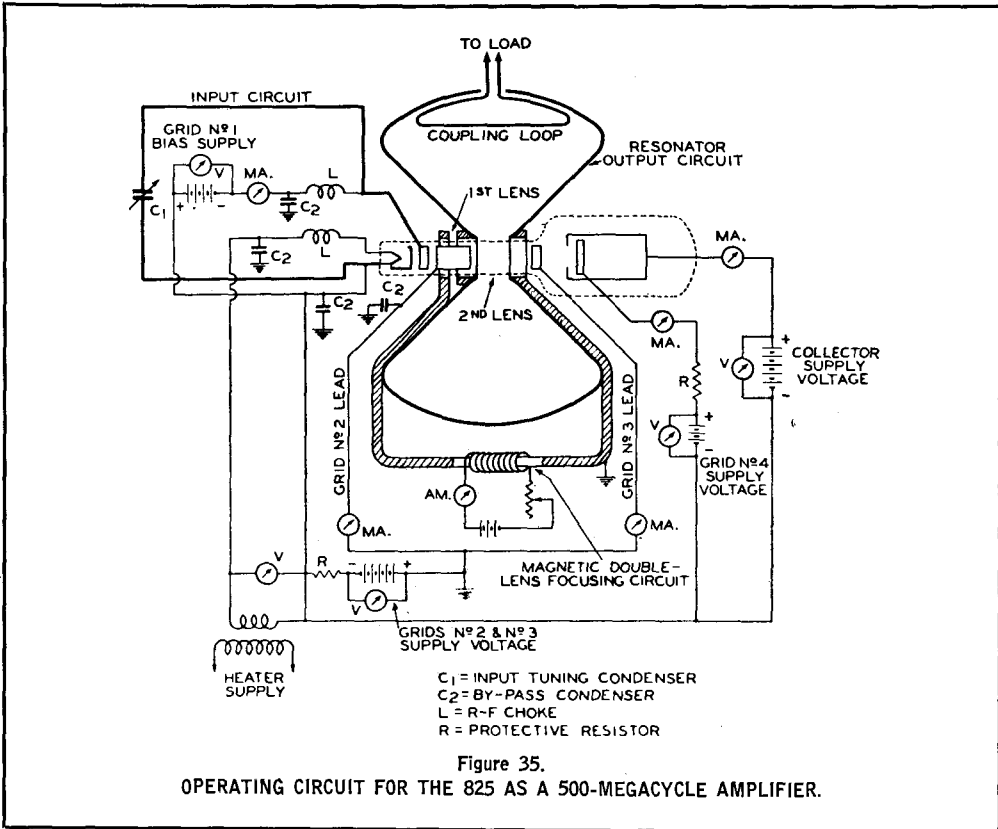

2 volts at 3.65 amperes. This particular oscillator gave outputs in excess of 5 watts on $\frac{3}{4}$ meter, even when no filament r.f. chokes were used.

Operation of the Oscillator. This oscillator, when loaded by an antenna, draws from 70 to 80 milliamperes at 400 volts plate supply. The oscillator should be tested at reduced plate voltage, preferably by means of a 1000- to 2000-ohm resistor in series with the positive B lead, until oscillation has been checked. A flashlight globe and loop of wire can be coupled to the parallel rods at a point near the voltage node, in order to indicate oscillation. A thermo-galvanometer coupled to a loop of wire makes a more sensitive indicator, but the high cost of this meter prohibits its use in most cases.

A 15-inch antenna rod or wire can be fed by a one- or two-wire feeder of the nonresonant type. A single-wire feeder can be capacitively coupled to the plate rod, either side of the voltage node, through a small blocking condenser. If a two-wire feeder is employed, a small coupling loop, placed parallel to the oscillator rods with the closed end of the loop near the voltage node of the oscillator, will provide a satisfactory means of coupling to the antenna.

UHF Antennas are described in *Chapter Twenty-one*.

Microwave Amplifiers

It is extremely difficult to get into operation any type of amplifier circuit of the conventional type at a frequency greater than about 250 Mc. The main reasons for this difficulty have been the extremely high amounts of loading of the interelectrode capacitances, the high inductances of leads to elements, and the practical impossibility of obtaining a satisfactory neutralizing arrangement. Quite recently, however, RCA announced an entirely new type of amplifier arrangement which had been under development for quite a period of time. In the new circuit arrangement the output tuned circuit is inductively coupled to a stream of high-velocity electrons within a vacuum tube especially designed for the purpose. Since there is no coupling other than the purely inductive coupling between the electron stream and the output tank circuit, all the difficulties mentioned above have been averted.

A new vacuum tube especially designed for this service, the 825, has been placed upon the market. It is called an *inductive output amplifier* and is suitable for operation on frequencies above 300 Mc. Figure 35 shows a diagram of an inductive amplifier stage which is capable of delivering an output of 35 watts at a frequency of 500 megacycles.

CHAPTER TWENTY

Antennas

Radio Waves and Their Propagation

Radio waves consist of condensations and refractions of energy traveling through space with the speed of light (186,000 miles or 300,000,000 meters per second). These waves have an electrostatic and an electromagnetic component. The electrostatic component may be considered as corresponding to the voltage of the wave and the electromagnetic component to the wave current. Radio waves not only travel with speed of light but can be refracted and reflected much the same as light waves.

Polarization. Like light waves, radio waves can have a definite polarization. In fact, while light waves ordinarily have to be reflected or passed through a polarizing medium before they have a definite polarization, a radio wave leaving a simple radiator will have a definite polarization, the polarization being indicated by the orientation of the electrostatic component of the wave. This in turn is determined by the orientation of the radiator itself, as the electromagnetic component is always at right angles to a linear radiator and the electrostatic component is always in the same plane as the radiator. Thus we see that an antenna that is vertical with respect to the earth will transmit a vertically polarized wave, as the electrostatic lines of force will be vertical. Likewise a simple horizontal antenna will radiate horizontally polarized waves.

Because the orientation of a simple linear radiator is the same as the polarization of the waves emitted by it, the radiator itself is referred to as being either vertically or horizontally polarized. Thus we say that a horizontal antenna is horizontally polarized.

The Ionosphere. A simple transmitting antenna or radiating system sends out radio waves in nearly all directions, though the strength of the waves may be greater in certain directions, and at certain angles above the earth. High frequency energy radiated

along the surface of the earth is rapidly attenuated and is of little use for consistent communication over distances exceeding 50 or 75 miles. That part of the radiated energy which is sent up at an angle above the horizon is partly returned to earth by the bending effect produced by the varying density of the ionized particles in the various layers of the *ionosphere*.

The ionosphere consists of layers of ionized particles of gas located above the stratosphere and extending up to possibly 750 miles above the earth. Thus we see that high-frequency radio waves may travel over short distances in a direct line from the transmitter to the receiver, or they can be radiated upward into the ionosphere to be bent downward in an indirect ray, returning to earth at considerable distance from the transmitter. The wave reaching a receiver via the ionosphere route is termed a *sky wave*. The wave reaching a receiver by traveling in a direct line from the transmitting antenna to the receiving antenna is commonly called a *ground wave* or *surface wave*.

The amount of bending which the sky wave undergoes depends upon the frequency of the wave and the amount of *ionization* in the ionosphere, which is in turn dependent upon radiation from the sun. The sun increases the density of the ionosphere layers and lowers their effective height. For this reason radio waves act very differently at different times of day and at different times of the year.

The higher the frequency of a radio wave the farther it penetrates the ionosphere and the less it tends to be bent back toward the earth. The lower the frequency the more easily the waves are bent and the less they penetrate the ionosphere. 160-meter and 80-meter signals will usually be bent back to earth even when sent almost straight up, and may be considered as being *reflected* rather than *refracted*. As the frequency is raised beyond about 5,000 kc. (dependent

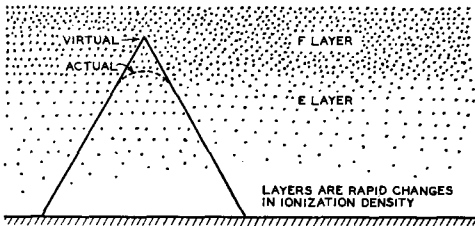
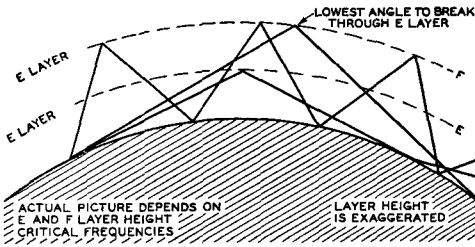

Figure 1.

Illustrating how the ionized atmosphere or ionosphere layer can bend radio waves back to earth, and some of the many possible paths of a high-frequency sky wave signal.

upon the critical frequency of the ionosphere at the moment) it is found that waves transmitted at angles higher than a certain critical angle *never return to earth*. Thus on the higher frequencies it is usually desirable to confine radiation to low angles, since the high angle waves simply penetrate the ionosphere and keep right on going, never returning to earth.

Signals above about 45,000 kc. are bent so slightly that they seldom return to earth regardless of the vertical angle of radiation, although, under exceptional circumstances radio waves of 75,000 kc. have been known to return to earth for very short periods of time. Thus sky wave propagation does not permit *consistent* communication at frequencies of 45,000 kc. In fact, the results on frequencies above 22,000 kc. are not considered sufficiently consistent for commercial use.

Skip Distance. The ground wave of a 14,000-ke. transmitter can seldom be heard over 100 miles away. Also, the first bending of the sky wave rarely brings it back down to earth within 300 miles from the 14,000-ke. transmitting antenna at night. Thus there is an area including all distances between 100 and 300 miles from the transmitter in which the signals are not ordinarily heard. The

closest distance at which sky waves return to earth is called the *skip distance*. In the skip zone no reception is possible, but moving closer to or farther away from the transmitter allows the signals to be heard.

Fading. The lower the angle of radiation of the wave, with respect to the horizon, the farther away will the wave return to earth and the greater the skip distance. The wave can be reflected back up into the ionosphere by the earth and then be reflected back down again, causing a second skip distance area. The drawing of figure 1 shows the multiple reflections possible. When the receiver receives signals which have traveled over more than one path between transmitter and receiver, the signal impulses will not all arrive at the same instant as they do not all travel the same distance. When two or more signals arrive in the same phase at the receiving antenna, the resulting signal in the receiver will be quite loud. On the other hand, if the signals arrive 180 degrees out of phase so they tend to neutralize each other, the received signal will drop—perhaps to zero if perfect neutralization occurs. This explains why high-frequency signals fade in and out.

Fading can be greatly reduced on the high frequencies by using a transmitting antenna with sharp vertical directivity, thus cutting down the number of multiple paths of signal arrival. A receiving antenna with similar characteristics (sharp vertical directivity) will further reduce fading. It is desirable when using antennas with sharp vertical directivity to use the lowest vertical angle consistent with good signal strength for the frequency used. This cuts down the number of hops the signal has to make to reach the receiver, and consequently reduces the chance for arrival via different paths.

Selective Fading. Selective fading affects all modulated signals. Modulated signals are not a single frequency signal but consist of a narrow band of waves perhaps fifteen kc. wide. It will be seen that the whole modulated signal band may not be neutralized at any instant, but only part of it. Likewise most of the carrier may be suppressed, or one sideband may be attenuated more than the other. This causes a peculiar and changing form of audio distortion at the receiver, which is known as *selective fading*.

Angle of Radiation. For a certain frequency, ionosphere height and transmitting distance there is an optimum angle with the horizon at which the radio wave should be propagated. For extremely long distance communication the angle of radiation should be low (5 to 15 degrees above the horizon) re-

ardless of the frequency used, so that the wave may arrive in the fewest possible jumps. For comparatively short distance communication (between 100 and 400 miles) the optimum angle of radiation will be considerably higher, but because very high frequency waves are not readily bent and penetrate the ionosphere when striking it at too steep an angle, we see that the shorter wavelengths are not satisfactory for short distance communication. Thus we have the skip distance or zone of silence previously referred to. Different types of antennas have different major angles of radiation with respect to the earth and the antenna, as will be shown later.

Antenna Radiation.

Alternating current passing through a conductor creates an alternating electromagnetic field around that conductor. Energy is alternately stored in the field and then returned to the conductor. As the frequency is raised, more and more of the energy does not return to the conductor but instead is radiated off into space in the form of electromagnetic waves, called radio waves. Radiation from a wire or wires is materially increased whenever there is a sudden *change* in the *electrical constants* of the line. These sudden changes produce reflection, which places *standing waves* on the line.

When a wire in space is fed radio frequency energy having a wavelength of approximately 2.08 times the length of the wire in meters it *resonates* as a *dipole* or half-wave antenna at that wavelength or frequency. The greatest possible change in the electrical constants of a line is that which occurs at the open end of a wire. Therefore a dipole has a great mismatch at each end, producing a high degree of reflection. We say that the dipole is terminated in an infinite impedance (open circuit). An incident radio frequency wave traveling to one end of the dipole is reflected right back towards the center of the dipole after reaching the end as there is no place else for it to go.

A returning wave which has been reflected meets the next incident wave and the voltage and current at any point along the antenna are the algebraic sum of the two waves. At the ends of the dipole the voltages add up while the currents and the two waves cancel, thus producing *high voltage* and *low current* at the *ends* of the dipole or half-wave section of wire. In the same manner it is found that the currents add up while the voltages cancel at the center of the dipole. Thus at the

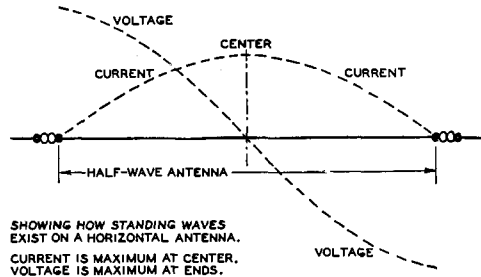

Figure 2.

center there is *high current* but *low voltage*.

Inspection of figure 2 will show that the current in a dipole decreases sinusoidally towards either end while the voltage similarly increases. The voltages at the two ends of the antenna are 180 degrees out of phase, which means that the polarities are opposite, one being plus while the other is minus at any instant. A curve representing either the voltage or current on a dipole represents a *standing wave* on the wire. If the voltage or current measured the same all along the wire it would indicate the absence of standing waves. The latter condition can exist only when energy is absorbed from one end of a wire or line exactly at the same rate it is supplied to the other end. The latter condition is covered thoroughly later in the chapter under the heading of "Untuned Transmission Lines." Many transmission lines do not have uniform voltage and current along their length and thus have standing waves the same as a dipole or antenna radiator.

A point of maximum current on a radiator or tuned resonant transmission line ordinarily corresponds to a point of minimum voltage. A *loop* means a point of *maximum* current or voltage, while a *node* refers to a point of *zero* or *minimum* current or voltage. Thus we see that a voltage loop corresponds to a current node and vice versa. In a wire or line containing reactance this is not strictly true, but in amateur work both antennas and tuned transmission lines are operated at resonance and the reactance therefore is negligible.

A two-wire resonant line does not radiate appreciably in spite of its high reflection and consequent standing waves because the radiation from the two adjacent wires is of opposite polarity or phase and equal in amplitude, thus cancelling out. In other words, the radiation from one point is absorbed or neutralized by the other wire and vice versa.

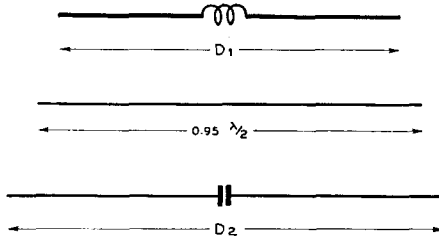

Figure 3.

THREE ANTENNAS ALL EQUAL ELECTRICALLY TO ONE HALF WAVELENGTH.

The top antenna is inductively lengthened. The bottom one is capacitively shortened. A coil will have the most lengthening effect and a condenser the most shortening effect when located at a current loop.

Frequency and Antenna Length. All antennas commonly used by amateurs, excepting the terminated rhombic, are based on the fundamental Hertz type, which is a wire in space a half wavelength long electrically. A resonant dipole which is a half wavelength long *electrically* is actually slightly less than a half wave long *physically*, due to the "end effects" and the fact that the velocity of a high-frequency radio wave traveling along the conductor is not quite as high as it is in free space.

If the cross section of the conductor is kept small compared to a half-wavelength, this effect is relatively constant, so that an electrical half wave is a fixed percentage shorter than a physical half-wavelength. This percentage is approximately 5 per cent. Therefore most half-wave antennas are really 95 per cent of a half wave long. Thus a half-wave antenna resonant at exactly 80 meters would be one half of 0.95 times 80 meters in length. Another way of saying the same thing is that a wire resonates at a wavelength of about 2.1 times its length in meters. If the diameter of the conductor begins to be an appreciable fraction of a wavelength, as when copper tubing is used as a u.h.f. radiator, the factor becomes slightly less than 0.95. For most purposes, however, the figure of 0.95 may be taken as accurate. This assumes a radiator removed from surrounding objects and with *no bends*.

Simple conversion into feet can be obtained by using the factor 1.56. To find the physical length of a half-wave 80-meter antenna we multiply 80 times 1.56 and get 124.8 feet for the length of the radiator.

It is more common to use frequency than wavelength when indicating a specific spot

in the radio spectrum. For this reason the relationship between wavelength and frequency must be kept in mind. As the velocity of radio waves through space is constant at the speed of light, it will be seen that the more waves that pass a point per second (higher the frequency), the closer together the peaks of those waves must be (higher the wavelength). Therefore the higher the frequency the lower the wavelength.

Frequency describes the number of wave peaks passing a point per second. Wavelength describes the distance in meters between adjacent peaks of a wave train.

A radio wave in space can be compared to a wave in water. The wave in either case has peaks and troughs. One peak and one trough constitute a *full wave* or *one wavelength*.

As a radio wave travels 300,000,000 meters a second (speed of light), a frequency of one cycle per second corresponds to a wavelength of 300,000,000 meters. So if the frequency is multiplied by a million the wavelength must be divided by a million in order to maintain their correct ratio.

A frequency of one million cycles per second (one thousand kc.) equals a wavelength of 300 meters. Multiplying frequency by ten and dividing wavelength by ten, we find: a frequency of 10,000 kc. equals a wavelength of 30 meters. Multiplying by ten and dividing by ten again we get: a frequency of 100,000 kc. equals 3 meters wavelength. Therefore to change wavelength to frequency simply divide 300,000 by the wavelength in meters. The wavelength in meters equals 300,000 divided by frequency in kc.

$$F_{\text{kc}} = \frac{300,000}{\lambda}$$

$$\lambda = \frac{300,000}{F_{\text{kc}}}$$

Now that we have a simple conversion formula for converting wavelength to frequency and vice versa, we can combine it with our wavelength versus antenna length formula and we have the following:

Wire length of half-wave radiator, in

$$\text{feet} = 1.56\lambda = \frac{467,400}{F_{\text{kc}}} = \frac{467.4}{F_{\text{Mc}}}$$

The slight discrepancy between the answers that will be obtained by the wavelength formula and by the frequency formula is due to the fact that the factor 1.56 is given only to two decimal places, this degree of

accuracy being sufficient for ordinary purposes. Actually the factor is 1.558, but 1.56 is close enough and simplifies calculations.

Harmonic Resonance. A wire in space resonates at more than one frequency. The lowest frequency at which it resonates is called its *fundamental* frequency, and at that frequency it is approximately a half wavelength long. A wire can have two, three, four, five or more standing waves on it, and thus resonates at approximately the *integral* harmonics of its fundamental frequency. However, the higher harmonics are not exactly integral multiples of the lowest resonant frequency as end effects influence only the outer quarter waves.

As the end effect comes in *only* at the ends, regardless of whether the antenna has its minimum resonant length or any of the longer resonant lengths (harmonic resonance), the equivalent electrical length approaches the actual physical length more and more, as the antenna length, measured in wavelengths, increases.

The following two formulas can be used to determine either the frequency or length of a wire with a given number of half waves on it. These formulas are accurate between 3000 and 30,000 kc.

$$L = \frac{492 (K - .05)}{F_{Mc}}$$

$$F_{Mc} = \frac{492 (K - .05)}{L}$$

Where F equals frequency in *megacycles*.
L equals length in feet.

K equals number of half waves on wire.

Antenna Impedance. In many ways a half-wave antenna is like a tuned tank circuit. The main difference lies in the fact that the elements of inductance, capacity and resistance are *lumped* in the tank circuit and are *distributed* throughout the length of an antenna. The center of a half-wave radiator is effectively at ground potential as far as r.f. voltage is concerned, although the current is highest at that point. See figure 2.

When the antenna is resonant, and it always should be for best results, the impedance at the center is a pure resistance and is termed the radiation resistance. Radiation resistance is a fictitious term; it is that value of resistance which would dissipate the same amount of power that is being radiated by the antenna.

The radiation resistance at the voltage node (current loop; in other words, minimum

voltage and maximum current) depends on the length of the antenna and its proximity to nearby objects which either absorb or re-radiate power, such as the ground, other wires, etc.

Before going too far with the discussion of radiation resistance an explanation of the Marconi (grounded quarter wave) antenna is in order. The Marconi antenna is a special type of Hertz antenna in which the earth acts as the "other half" of the dipole. In other words, the current flows into the earth instead of into a similar quarter-wave section. Thus the current loop of a Marconi antenna is at the *base* rather than in the *center*. In either case it is a quarter wavelength from the end (or ends).

A half-wave dipole far from ground and other reflecting objects has a radiation resistance at the center of 73.14 ohms. Radiation resistance is ordinarily referred to a current loop. Otherwise it has no particular significance because it could be most any value if the point on the antenna were not given.

A Marconi antenna radiates only half as much energy as a dipole for a given impressed voltage. For that reason the radiation resistance is roughly half 73 ohms.

Because the power throughout the antenna is the same, the impedance of the antenna at any point along its length merely expresses the ratio between voltage and current at that point. Thus the lowest impedance occurs where the current is highest, namely, at the center of a dipole or a quarter wave from the end of a Marconi. The impedance rises uniformly toward each end, where it is approximately 2400 ohms for a dipole remote from ground and about twice as high for a vertical Marconi.

If a vertical half-wave antenna is set up so that its lower end is at the ground level, the effect of the ground reflection is to increase the radiation resistance to approximately 100 ohms. When a horizontal half-wave antenna is used, the radiation resistance (and, of course, the amount of energy radiated for a given antenna current) depends on the height of the antenna above ground, since the height determines the phase angle between the wave radiated directly in any direction and the wave which combines with it after reflection from the ground.

The radiation resistance of an antenna generally increases with length, although this increase varies up and down about a constantly increasing average. The peaks and dips are caused by the reactance of the antenna when its length does not allow it to resonate at the operating frequency.

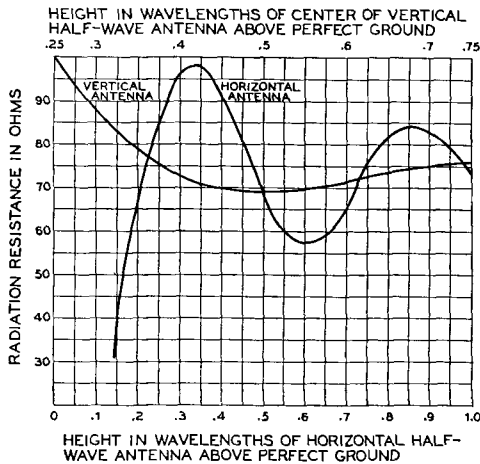

Figure 4.
EFFECT OF HEIGHT ON THE RADIATION
RESISTANCE OF A DIPOLE SUSPENDED
ABOVE PERFECT GROUND.

Antennas have a certain loss resistance as well as a radiation resistance. The loss resistance defines the power lost in the antenna due to ohmic resistance of the wire, ground resistance, corona discharge and insulator losses.

Resonance. Most antennas operate best when resonated to the frequency of operation. This does not apply to the terminated rhombic antenna or to the *parasitic* elements of one popular type of close-spaced array to be described later in the chapter. However, in practically every other case it will be found that increased efficiency results when the entire antenna system is resonant whether it be a simple dipole or an elaborate array. The radiation efficiency of a resonant wire is many times that of a wire which is not resonant.

If an antenna is slightly too long it can easily be resonated by means of a variable capacitor. If it is slightly too short, it can be easily resonated by means of a variable inductance. These two methods are generally employed when part of the antenna is brought into the operating room.

With an antenna array, or an antenna fed by means of a transmission line, it is more common to cut the elements to exact resonant length by "cut and try" procedure. Exact antenna resonance is more important when the antenna system has low radiation resistance; an antenna with low radiation resistance has higher Q (tunes sharper) than an antenna with high radiation resistance.

CHARACTERISTICS AND CONSIDERATIONS

Radiation Resistance. Along a half-wave antenna the *impedance* varies from a minimum at the center to a maximum at the ends. The impedance is that property which determines the antenna current at any point along the wire for the value of radio-frequency voltage at that point. The main component of this impedance is the radiation resistance; normally the latter is referred to the center of the half-wave antenna where the current is at maximum. The square of the current multiplied by the radiation resistance is equal to the power radiated by the antenna. For convenience, these values are usually referred to the center of a half-wave section of antenna.

The curves of figure 4 indicate the theoretical center-point radiation resistance of a half-wave antenna for various heights above perfect ground. These values are of importance in matching untuned radio-frequency feeders to the antenna in order to obtain a good impedance match and an absence of standing waves on the feeders.

Above *average* ground, the actual radiation resistance of a dipole will vary from the exact value of figure 4, since the latter assumes a hypothetical perfect ground having no loss and perfect reflection. Fortunately, the curves for the radiation resistance over most types of earth will correspond rather closely with those of the chart, except that the radiation resistance for a horizontal dipole does not fall off as rapidly as is indicated for heights below an eighth wavelength. However, with the antenna so close to the ground and the soil in a strong field, much of the radiation resistance is actually represented by ground loss; this means that a good portion of the antenna power is being dissipated in the earth, which, unlike the hypothetical perfect ground, has resistance. The type of soil also has an effect upon the radiation *pattern*, especially in the vertical plane, as will be seen later.

When the radiation resistance of an antenna or array is very low, the current at a voltage node will be quite high for a given power. Likewise, the voltage at a current node will be very high. Even with a heavy conductor and excellent insulation, the losses due to the high voltage and current will be appreciable if the radiation resistance is sufficiently low.

Usually, it is not considered desirable to use an antenna or array with a radiation resistance of less than approximately 10 ohms

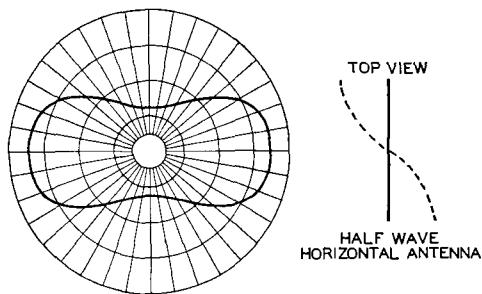

Figure 5.
RADIATION PATTERN OF A HALF-WAVE ANTENNA A HALF WAVE ABOVE PERFECT GROUND, FOR A FIXED VERTICAL ANGLE OF 30°.

unless there is sufficient directivity, compactness or other advantage to offset the losses resulting from the low radiation resistance.

Ground Resistance. The radiation resistance of a Marconi antenna, especially, should be kept as high as possible. This will reduce the antenna current for a given power, thus minimizing loss resulting from the series resistance offered by the earth connection. The radiation resistance can be kept high by making the Marconi radiator somewhat longer than a quarter wave and shortening it by series capacity to an electrical quarter wave. It should also be removed from ground as much as possible (vertical being ideal). Methods of minimizing the resistance of the earth connection will be found in the discussion of the Marconi antenna.

Antenna Directivity

When choosing and orienting an antenna system, the radiation patterns of the various common types of antennas should be given careful consideration. The directional characteristics are of still greater importance when a directive antenna array is used.

There are two kinds of antenna directivity: vertical and horizontal. The latter is not generally desirable for amateur work except (1) for point-to-point work between stations regularly communicating with each other, (2) where several arrays are so placed as to cover most useful directions from a given location, and (3) when the beam may be directed by electrical or mechanical rotation.

Considerable horizontal directivity can be used to advantage for point-to-point work. Signals follow the great circle path or are within 2 or 3 degrees of that path a good share of the time.

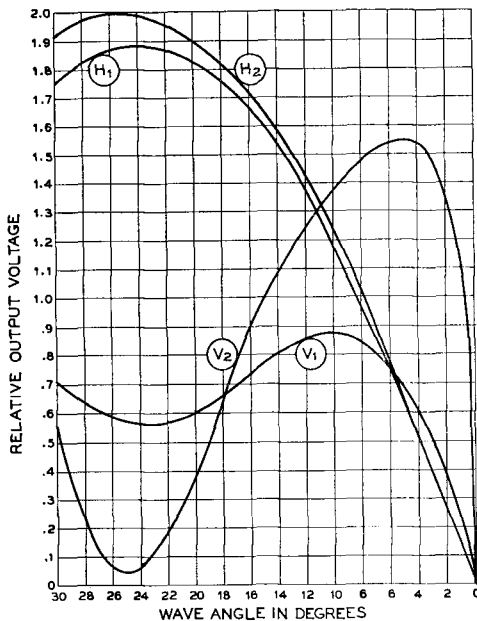

Figure 6.
VERTICAL-PLANE DIRECTIONAL CHARACTERISTICS OF HORIZONTAL AND VERTICAL DOUBLET ELEVATED 0.6 WAVELENGTH AND ABOVE TWO TYPES OF GROUND.

H₁ represents a horizontal doublet over typical farmland, H₂ over salt water. V₁ is a vertical pattern of radiation from a vertical doublet over typical farmland, V₂ over salt water. A salt water ground is the closest approach to an extensive ideally perfect ground that will be met in actual practice.

For general amateur work, however, too much horizontal directivity is ordinarily undesirable, inasmuch as it necessitates having the beam pointed exactly at the station being worked. Making the array rotatable overcomes this obstacle, but arrays having extremely high horizontal directivity are too cumbersome to be rotated, except perhaps above 56 Mc. The horizontal directivity of a horizontal dipole depends upon the vertical angle being considered. Directivity is greater for lower vertical angles. This polar diagram, figure 5, shows a typical horizontal radiation pattern.

On the 28- and 14-Mc. bands, and to an extent on the 7-Mc. band, the matter of vertical directivity is of as much importance as is horizontal directivity. Only the power leaving the antenna at certain vertical angles is instrumental in putting a signal into a distant receiving antenna; the rest may be

considered as largely wasted. In other words the important thing is the amount of power radiated in a desired direction *at the useful vertical angles*, rather than the actual shape of the directivity curves as read on the ground by a field strength meter, the latter giving only a pattern of the *ground wave*.

A nondirectional antenna such as a vertical or horizontal dipole will give excellent results with general coverage on 28 and 14 Mc. if the vertical angle of radiation is favorable. The latter type is slightly directional broad-side, especially on 28 Mc. where only very low angle radiation is useful, but is still considered as a "general coverage" type.

Effect of Average Ground on Antenna Radiation. Articles appearing in journals discussing antenna radiation often are based upon the perfect ground assumption in order to cover the subject in the most simple manner. Yet, little has been said about the real situation which exists, the ground generally being everything but a perfect conductor. Consideration of the effect of a ground that is not perfect explains many things.

When the earth is less than a perfect conductor, it becomes a dielectric or, perhaps in an extreme case, a leaky insulator.

The resulting change in the vertical pattern of a horizontal antenna is shown in figure 6. The ground constants in this case are for flat farmland, which probably is similar to midwestern farmland. The ocean is the closest practical approach to a theoretically perfect ground. It will be noted that there is only a slight loss in power due to the imperfect ground as compared to the ocean horizontal.

The effect of the earth on the radiation pattern of a vertical dipole is much greater. Radiation from a half-wavelength vertical wire is severely reduced by deficiencies of the ground.

A very important factor in the advantages of horizontal or vertical dipoles, therefore, appears to be the condition of the ground.

The best angle of radiation varies with frequency, layer height and many other factors. For instance, a lower optimum vertical angle is found to hold for high-frequency communication with South America from the U.S.A. than for Europe and the U.S.A.

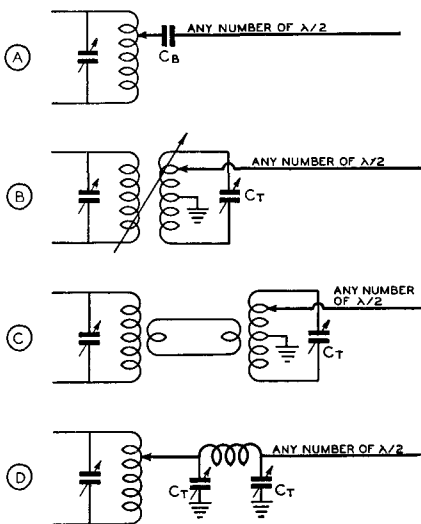

Figure 7.

FOUR METHODS OF END FEEDING AN ANTENNA.

The arrangement of "C" is to be recommended. The legality of arrangement "A" for amateur work is debatable if the blocking condenser is large. It is really a form of direct coupling, permitted by the regulations only when an untuned feed line is used.

FEEDING THE ANTENNA

Usually a high-frequency doublet or directional array is mounted as high and as much in the clear as possible for obvious reasons. Power can then be fed to the antenna system via one of the various transmission lines discussed in the latter portion of this chapter.

However, it is sometimes justifiable to bring part of the radiating system directly to the transmitter, feeding the antenna without benefit of a transmission line. This is permissible when (1) there is insufficient room to erect a 75- or 160-meter horizontal dipole and feed line, (2) when a long wire is operated on one of the higher frequency bands on a harmonic. In either case, it is usually possible to get the main portion of the antenna in the clear because of its length. This means that the power lost by bringing the antenna directly to the transmitter is relatively small.

Even so, it is not the best practice to bring the high-voltage end of an antenna into the operating room, especially for phone operation, because of the possibility of r.f. feedback from the strong antenna field. For this reason, one should dispense with a feed line in conjunction with a Hertz antenna only as a last resort.

End-Fed Antennas. The end-fed Fuchs (pronounced "Fooks") antenna has no form

of transmission line to couple it to the transmitter, but brings the radiating portion of the antenna right down to the transmitter where some form of coupling system is used to transfer energy to the antenna.

This antenna is always voltage-fed and always consists of an *even* number of quarter wavelengths. Figure 7 shows several common methods of feeding the Fuchs antenna or end-fed Hertz. Arrangement "C" is to be recommended to minimize harmonics, as an end-fed antenna itself offers no discrimination against harmonics, either odd or even.

The Fuchs type of antenna has rather high losses unless at least three-quarters of the radiator can be placed outside the operating room and in the clear. As there is high r.f. voltage at the point where the antenna enters the operating room, the insulation at that point should be several times as effective as the insulation commonly used with low-voltage feeder systems. This antenna can be operated on all of its higher harmonics with good efficiency, and can be operated at half frequency against ground as a quarter-wave Marconi.

As the frequency of an antenna is raised slightly when it is bent anywhere except at an exact voltage or current loop, a Fuchs antenna usually is a few per cent longer than a straight half-wave doublet for the same frequency, because it is ordinarily impracticable to bring a wire in to the transmitter without making several bends.

The Marconi Antenna

A grounded quarter-wave Marconi antenna is widely used on the 160-meter band due to the fact that a half-wave antenna at that low frequency is around 260 feet long, which is out of the question for those confined to an ordinary city lot. It is also widely used in u.h.f. mobile applications where a compact radiator is required.

The Marconi type antenna allows the use of half of the length of wire used for a half-wave Hertz radiator. The ground acts as a mirror, in effect, and takes the place of the extra quarter wave that would be required to resonate the wire, were it not grounded.

The Marconi antenna generally is not as satisfactory for long distance communication as the Hertz type, and the radiation efficiency is never as great, due to the losses in the ground connection. However, it can be made almost as good a radiator on 160 meters if *sufficient care is taken with the ground system.*

The fundamental Marconi antenna is shown in figure 8, and all Marconi antennas differ from this only in the method of feeding energy. Antenna A in figure 9 is the fundamental vertical type. Type B is the inverted-L type; type C is the T type with the two halves of the top portion of the T effectively in parallel.

The Marconi antenna should be as *high as possible*, and too much attention cannot be paid to getting a low resistance ground connection.

Importance of Ground Connection. With a quarter-wave antenna and a ground, the antenna current is generally measured with a meter placed in the antenna circuit close to the ground connection. Now, if this current flows through a resistor, or if the ground it-

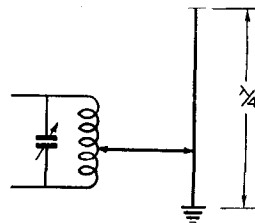
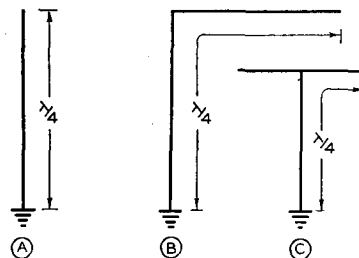

Figure 8.
THE SERIES-TUNED QUARTER-WAVE MARCONI, THE BASIC MARCONI ANTENNA SYSTEM.

The overall length to the earth connection, including lead in, is from 10% to 25% in excess of a quarter wavelength physically. The system is capacity-shortened and resonated by means of the series tuning condenser, which for 160 meters should have from .00025 to .0005 μfd. maximum capacity.

Figure 9.
THREE COMMON VARIATIONS OF THE MARCONI ANTENNA.

The bottom half of the radiator does most of the radiating, regardless of which type is used, because the current is greatest close to ground.



self presents some resistance, there will definitely be a power loss in the form of heat. Improving the ground connection, therefore, provides a definite means of reducing this loss of antenna power and thus increasing the radiated power.

The best possible ground consists of as many wires as possible, each at least a quarter wave long, buried just below the surface of the earth and extending out from a common point in the form of radials. Copper wire of any size larger than no. 16 is satisfactory, though the larger sizes will take longer to disintegrate. In fact, the radials need not even be buried; they may be supported just above the earth and insulated from it. This arrangement is called a *counterpoise*, and operates by virtue of its high capacity to ground.

Unless a large number of radials are used, fairly close to the ground, the counterpoise will act more like the bottom half of a half-wave Hertz than like a ground system. However, the efficiency with a counterpoise will be quite good, regardless. It is when the radials are buried or laid on the ground that a large number should be used for best efficiency. Broadcast stations use as many as 120 radials of from 0.3 to 0.5 wavelength long.

A large number of radials not only provides a low resistance earth connection but also, if long enough, produces the effect of locating the radiator over highly conducting earth. The importance of the latter with regard to vertical antennas is illustrated in figure 6.

When it is impossible to extend buried radials in all directions from the ground connection for an inverted-L type Marconi, it is of importance that a few wires be buried directly below the flat top and spaced at least 10 feet from one another.

If the antenna should be physically shorter than a quarter wavelength, antenna current would be higher, due to lower radiation resistance. Consequently, the power lost in resistive soil would be greater. The importance of a good ground with short, inductive-loaded Marconi radiators is, therefore, quite obvious. With a good ground system, even very short (one-eighth wavelength) antennas can be expected to give upwards from 90% of the efficiency of a quarter-wave antenna used with the same ground system. This is especially true when the short radiator is *top loaded* with a high Q (low loss) coil. In this type radiator the loading coil is placed near the top of the radiator rather than at the bottom.

Water Pipe Grounds. Water pipe, because of its comparatively large surface and

cross section, has about as low an r.f. resistance as copper wire. If it is possible to attach to a junction of several water pipes (where they branch in several directions and run for some distance under ground), a satisfactory ground connection will be obtained. If one of the pipes attaches to a lawn or garden sprinkler system in the immediate vicinity of the antenna, and runs hither and thither to several neighboring faucets within a radius of a hundred yards, the effectiveness of the system will approach that of buried copper radials.

The main objection to water pipe grounds is the possibility of high resistance joints in the pipe due to the "dope" put on the coupling threads. By attaching the ground wire to a junction with three or more legs, the possibility of requiring the main portion of the r.f. current to flow through a high resistance connection is greatly reduced.

The presence of water in the pipe adds but little to the conductivity; therefore it does not relieve the problem of high resistance joints. Bonding the joints is the best insurance, but this is, of course, impracticable where the pipe is buried. Bonding together with copper wire the various water faucets above the surface of the ground will improve the effectiveness of a water pipe ground system hampered by high resistance pipe couplings.

Marconi Dimensions. A Marconi antenna is exactly an odd number of electrical quarter waves long (usually only one quarter wave in length), and is always resonated to the operating frequency. The correct loading of the final amplifier is accomplished by varying the coupling *rather than by detuning the antenna from resonance.*

Physically, a quarter-wave Marconi may be made anything from one-eighth to three-eighths wavelength overall, meaning the total length of the antenna wire and ground lead from the end of the antenna to the point where the ground lead attaches to the junction of the radials or counterpoise wires or the water pipe enters the ground. The longer the antenna is made physically, the lower will be the current flowing in the ground connection and the greater will be the overall radiation efficiency. However, when the antenna length exceeds three-eighths wavelength, the antenna becomes difficult to resonate by means of a series condenser, and it begins to take shape as an end-fed Hertz, requiring a different method of feed than that illustrated in figure 8 for current feed of a Marconi.

A radiator physically shorter than a quarter wavelength can be lengthened electrically by means of a series loading coil, and used as a quarter-wave Marconi. However, if the wire is made shorter than approximately one-eighth wavelength, the radiation resistance will be so low that high efficiency cannot be obtained even with a very good ground.

Loading Coils. To resonate inductively an inductive-loaded Marconi, the inductance would have to be in the form of a variometer in order to permit continuous variation of the inductance. The more common practice is to use a tapped loading coil and a series tuning condenser. The loading coil should preferably be placed a short distance from the *top or far end* of the radiator; this reduces the current flowing in the ground connection by raising the radiation resistance, resulting in better radiation efficiency. More than the required amount of inductance for resonance is clipped in series with the antenna, and the system is then resonated by means of the series variable condenser the same as though the radiator were actually too long physically.

To estimate whether a loading coil will probably be required, it is necessary only to note if the length of the antenna wire and ground lead is over a quarter wavelength; if so, no loading coil should be required, provided the series tuning condenser has a high maximum capacity.

Those primarily interested in the higher frequency bands but who like to work 160 meters occasionally can usually manage to resonate one of their antennas as a Marconi by working the whole system, feeders and all, against a water pipe ground and resorting to a loading coil if necessary. A high-frequency zepp, doublet or single-wire-fed antenna will make quite a good 160-meter Marconi if high and in the clear, with a rather long feed line to act as a radiator on 160 meters. Where two-wire feeders are used, the feeders should be tied together for Marconi operation.

TRANSMISSION LINES

For many reasons it is desirable to place a radiator as high and as much in the clear as possible, utilizing some form of nonradiating transmission line to carry energy with as little loss as possible from the transmitter to the radiating antenna.

There are many different kinds of transmission lines, and generally speaking, practically any type of transmission line or feeder

system can be used with any type of antenna; however, certain types are often better adapted than others for use with a certain antenna.

Transmission lines are of two general types: resonant and nonresonant. Strictly speaking, the term *transmission line* should really only be applied to a *nonresonant line*. Strictly speaking, a *resonant line* should be termed a *feeder system*, such as zepp feeders, etc. However, *transmission line* has come to refer to either type of line, tuned or untuned.

The principal types of nonresonant transmission lines include the single-wire-feed, the two-wire open and the twisted-pair matched impedance, the coaxial (concentric) feed line and the multi-wire matched-impedance open line.

Voltage Feed and Current Feed. The half-wave Hertz antenna has high voltage and low current at each end, and it has low voltage and high current at its center. As any ungrounded resonant antenna consists merely of one or more half-wave antennas placed end to end, it will be seen that there will be a point of high r.f. voltage every half wave of length measured from either end of the antenna. Also, there will be a point of high r.f. current half-way between any two adjacent high voltage points.

A voltage-fed antenna is any antenna which is excited at one of these high voltage points or, in other words, a point of high impedance. Likewise, a current-fed antenna is one excited at a point along the antenna where the current is high and the voltage low, which corresponds to a point of low impedance.

The Zepp Antenna

The zepp antenna system is easy to tune up and can be used on several bands by merely retuning the feeders. The overall efficiency of the zepp antenna system is probably not quite as high for long feeder lengths as some of the antenna systems which employ nonresonant transmission lines, but where space is limited and where operation on more than one band is desired, the zepp has some decided advantages.

Zepp feeders really consist of an additional length of antenna which is folded back on itself so that the radiation from the two halves cancels. In figure 10A is shown a simple Hertz antenna fed at the center by means of a pickup coil. Figure 10B shows another half-wave radiator tied directly on one end of the radiator shown in figure 10A. Figure

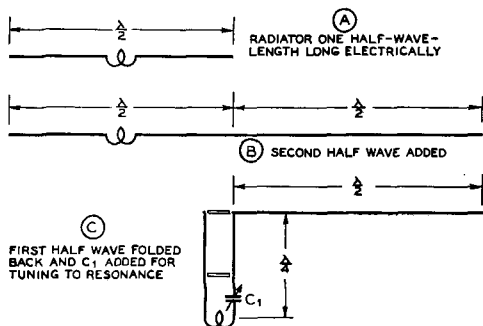

Figure 10.
THE EVOLUTION OF A ZEPP ANTENNA.

10C is exactly the same thing except that the first half-wave radiator, in which is located the coupling coil, has been folded on itself. In this particular case, each half of the folded part of the antenna is exactly a quarter-wave long electrically.

Addition of the coupling coil naturally will electrically lengthen the antenna; thus, in order to bring this portion of the antenna back to resonance, we must electrically shorten it by means of the series tuning condenser, C_1 . The two wires in the folded portion of the antenna system do not have to be exactly a quarter wave long physically although the total *electrical* length of the folded portion must be equal to one-half wavelength electrically.

When the total electrical length of the two feeder wires plus the coupling coil is slightly greater than any odd multiple of one-quarter wave, then series condensers must be used to shorten the electrical length of the feeders sufficiently to establish resonance. If, on the other hand the electrical length of the feeders and the coupling coil is slightly less than any odd multiple of one-quarter wave, then parallel tuning (wherein a condenser is shunted across the coupling coil) must be used in order to increase the electrical length of the whole feeder system to a multiple of one-quarter wavelength.

As the radiating portion of the zepp antenna system must always be some multiple of a half wave long, there is always high voltage present at the point where the live zepp feeder attaches to the end of the radiating portion of the antenna. Thus, this type of zepp antenna system is *voltage fed*.

The idea that it takes two condensers to balance the current in the feeders, one condenser in each feeder, is a common miscon-

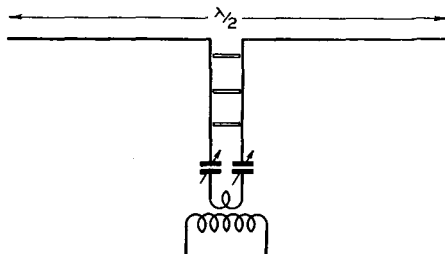

Figure 11.
THE TUNED DOUBLET USES AN OPEN-WIRE FEED SYSTEM.

The flat top need not be exactly an electrical half wave in length so long as the whole system, both flat top and feeders, is resonant as a unit. Only one tuning condenser need be used if desired. Certain feeder lengths will require that the condenser be placed across the coil rather than in series with it.

ception regarding the zepp type end-fed antenna. Balancing the feeders with tuning condensers for equal currents is useless anyhow, inasmuch as the feeders on an end-fed zepp can never be balanced for *both* current *and* phase because of the tendency for the end of the "dead" feeder to have more voltage on it than the one attached to the radiator.

Flat Top Length. The correct physical length for the flat top (radiating portion) of a zepp is *not* 0.95 of a half wavelength. Instead it is so close to a half wavelength that it may be taken as that figure. Thus, while a 7300-kc. doublet is 64 feet long, the flat top of a 7300-kc. zepp should be 67 feet 3 inches. The reason for this is readily apparent when it is remembered that the 5 per cent difference between a resonant doublet and a physical half wavelength is principally due to "end effects," $2\frac{1}{2}$ per cent at each end of the radiator.

Obviously there is no end effect at the end of a radiator to which zepp feeders are attached. Hence we lengthen the radiator $2\frac{1}{2}$ per cent. Now we must take into consideration that the end of the "dead" (unattached) feed wire has end effects and that the other feeder does not. We want the two voltage loops to come at the same point on the feed line in order to obtain the best possible balance so as to minimize radiation. So we make the dead feed wire $2\frac{1}{2}$ per cent of a half wavelength shorter than the other. This can be done quite easily merely by lengthening the flat top another $2\frac{1}{2}$ per cent. Thus the flat top is 5 per cent longer than if it were fed in the center.

The Tuned Doublet

A current-fed doublet with spaced feeders, sometimes erroneously called a center-fed zapp, is an inherently balanced system (if the two legs of the radiator are exactly equal electrically) and there will be no radiation from the feeders regardless of what frequency the system is operated on. A series condenser may be put in *one* feeder (if right at the coupling coil) without affecting the balance of the system. The system can successfully be operated on most any frequency if the system as a whole can be resonated to the operating frequency. This is usually possible with a tapped coil and a tuning condenser that can optionally be placed either across the antenna coil or in series with it.

This type of antenna system is shown in figure 11. It is a current-fed system on the lowest frequency for which it will operate, but becomes a voltage-fed system on all its even harmonics.

The antenna has a different radiation pattern when operated on harmonics, as would be expected. The arrangement used on the second harmonic is better known as the Franklin colinear array and is described later in this chapter. The pattern is similar to a half-wave doublet except that it is sharper in the broadside direction. On higher harmonics there will be multiple lobes.

Tuned Feeder Considerations

If a transmission line is terminated in its *characteristic surge impedance*, there will be no reflection at the end of the line and the current and voltage distribution will be uniform along the line. If the end of the line is either open-circuited or short-circuited, the reflection at the end of the line will be 100 per cent, and *standing waves* of very great amplitude will appear on the line. There will still be practically no radiation from the line, but voltage nodes will be found along the line spaced a half wavelength. Likewise, voltage loops will be found every half wavelength, the voltage loops corresponding to current nodes.

If the line is terminated in some value other than the characteristic surge impedance, there will be some reflection, the amount being determined by the amount of mismatch. With reflection, there will be standing waves (excursions of current and voltage) along the line, though not to the same extent as with an open-circuited or short-circuited line. The current and voltage loops will occur at the same *points* along the line as with the open-

or short-circuited line, and as the terminating impedance is made to approach the characteristic impedance of the line, the current and voltage along the line will become more uniform. The foregoing assumes, of course, a purely resistive (nonreactive) load.

A well built 500- to 600-ohm transmission line may be used as a resonant feeder for lengths up to several hundred feet with very low loss, so long as the amplitude of the standing waves (ratio of maximum to minimum voltage along the line) is *not too great*. The amplitude, in turn, depends upon the mismatch at the line termination. A line of no. 12 wire, spaced 6 inches with good ceramic or Lucite spreaders, has a surge impedance of approximately 600 ohms, and makes an excellent tuned feeder for feeding anything between 60 and 6000 ohms (at frequencies below 30 Mc.). If used to feed a load of higher or lower impedance than this, the standing waves become great enough in amplitude that some loss will occur unless the feeder is kept short.

If a transmission line is not perfectly matched it should be made *resonant*, even though the amplitude of the standing waves (voltage variation) is not particularly great. This prevents reactance from being coupled into the final amplifier. A feed system having moderate standing waves may be made to present a nonreactive load to the amplifier either by tuning or by pruning the feeders to approximate resonance.

Usually it is preferable with tuned feeders to have a current loop (voltage minimum) at the transmitter end of the line. This means that when voltage-feeding an antenna the tuned feeders should be made an odd number of quarter wavelengths long, and when current-feeding an antenna the feeders should be made an even number of quarter wavelengths long. Actually, the feeders are made about 10 per cent of a quarter wave longer than the calculated value (the same value given in the tables) when they are to be series tuned to resonance by means of a condenser instead of being trimmed and pruned to resonance.

When tuned feeders are used to feed an antenna on more than one band, it is necessary to compromise and make provision for both series and parallel tuning, inasmuch as it is impossible to cut a feeder to a length that will be optimum for several bands. If a voltage loop appears at the transmitter end of the line on certain bands, parallel tuning of the feeders will be required in order to get a transfer of energy. It is impossible to transfer energy by inductive coupling unless

current is flowing. This is effected at a voltage loop by the presence of the resonant tank circuit formed by parallel tuning of the antenna coil.

Methods of coupling to a transmitter are discussed later in the chapter.

Untuned Transmission Lines

A nonresonant or untuned line is a line with negligible standing waves. Physically, the line itself should be *identical throughout its length*; there will be a smooth distribution of voltage and current throughout its length, both tapering off very slightly towards the antenna end of the line as a result of line losses. The attenuation (loss) in certain types of untuned lines can be kept very low for line lengths up to several thousand feet. In other types, particularly where the dielectric is not air (such as in the twisted-pair line), the losses may become excessive at the higher frequencies unless the line is relatively short.

The termination at the antenna end is the only critical characteristic about the untuned line. It is the reflection from the antenna end which starts waves moving back toward the transmitter end. When waves moving in both directions along a conductor meet, standing waves are set up.

All transmission lines have distributed inductance, capacity and resistance. Neglecting the resistance, as it is of minor importance in short lines, it is found that the *inductance and capacity per unit length* determine the characteristic or surge impedance of the line. Thus, the surge impedance depends upon the nature and spacing of the conductors and the dielectric separating them.

When any transmission line is terminated in an impedance equal to its surge impedance, reflection of energy does not occur and no standing waves are present. When the load termination is exactly the same as the line impedance, it simply means that the load takes energy from the line just as fast as the line delivers it, no slower and no faster.

Thus, for proper operation of an untuned line (with standing waves eliminated), some form of impedance-matching arrangement must be used between the transmission line and the antenna so that the radiation resistance of the antenna is reflected back into the line as a nonreactive impedance equal to the line impedance. It is important that the *radiator itself be cut to exact resonance*; otherwise, it will not present a pure resistive load to the nonresonant line.

An untuned feeder system may consist of one, two, four or even more parallel wires. Increased constructional difficulties of the multi-wire type of line where three or more parallel wires are used and the danger of appreciable feeder radiation from an improperly adjusted single-wire feeder make the more familiar two-wire type of line the most satisfactory for general use.

Semi-Resonant Open Lines. As has been previously stated under "Tuned Feeder Considerations," a well built *open-wire* line has low losses even when standing waves with a ratio of as high as 10/1 are present. (The standing wave ratio will be found to approximate the ratio of mismatch at the feeder termination.) Of much greater importance is to make sure the line is *balanced*, which means that the antenna system must be electrically symmetrical or allowance made for the asymmetry. If the currents in the two feed wires are not equal in amplitude and exactly opposite in phase, there will be radiation from the line (or pickup by the line if used for receiving) regardless of the amplitude of standing waves.

Because moderate standing waves can be tolerated on open-wire lines without loss, a standing wave ratio of 2/1 or 3/1 is considered acceptable with this type of line *even when used in an "untuned" system*. Strictly speaking, a line is untuned or nonresonant only when the line is perfectly "flat," with a standing wave ratio of 1 (no standing waves). However, *some mismatch can be tolerated with open-wire untuned lines* so long as the reactance is not objectionable or else is eliminated by cutting the line to approximately a resonant length.

Thus we have a line that is a cross between a tuned and an untuned line. Most of the "untuned" open-wire lines used by amateurs fall in this class, because there is usually more or less of a mismatch at the line termination. Therefore *open-wire* lines with a standing wave ratio of *less than 3/1* may be classed as *nonresonant* or untuned lines, as standing waves will not affect the operation of an untuned line unless greater than this in magnitude.

The foregoing applies only to *open-wire lines*. The losses in other type lines, especially those having rubber dielectric, go up rapidly with the standing wave ratio, such lines being designed for perfectly "flat" operation. Also, the maximum power handling capability of lines such as the twisted pair and concentric is greatly reduced when standing waves are present, even though of

only 2/1 or 3/1 magnitude. From this we can see that every attempt should be made to eliminate all traces of standing waves on a low impedance, close-spaced line, especially when the power is high enough that there is danger of arc-over at voltage loops, or when the frequency is high enough that the losses are already so great that increased losses will be a serious item.

Construction of Two-Wire Open Lines.

A two-wire transmission system is easy to construct. Its surge impedance can be calculated quite easily, and when properly adjusted and balanced to ground, undesirable feeder radiation is minimized; the current flow in the adjacent wires is in opposite directions and the magnetic fields of the two wires are in opposition to each other. When a two-wire line is terminated with the equivalent of a pure resistance equal to the surge impedance of the line, the line becomes a non-resonant line. It is, then, the problem to find a way to go about calculating the surge impedance of any two-wire transmission line, which impedance we will call Z_s .

It can be shown mathematically that the true surge impedance of any two-wire parallel line system is approximately equal to

$$Z_s = 276 \log_{10} \frac{2S}{d}$$

Where:

S is the exact distance between wire centers in some convenient unit of measurement, and

d is the diameter of the wire measured in the same units as the wire spacing, S .

Since $\frac{2S}{d}$ expresses a ratio only, the units

of measurement may be centimeters, millimeters or inches. This makes no difference in the answer so long as the substituted values for S and d are in the same units.

The equation is accurate so long as the wire spacing is relatively large as compared to the wire diameter.

Surge impedance values of less than 200 ohms are seldom used in the open-type two-wire line and, even at this comparatively high value of Z_s , the wire spacing S is uncomfortably close, being only 5.3 times the wire diameter d .

Figure 12 gives in graphical form the surge impedance of any practicable two-wire line. The chart is self-explanatory and sufficiently accurate for practical purposes.

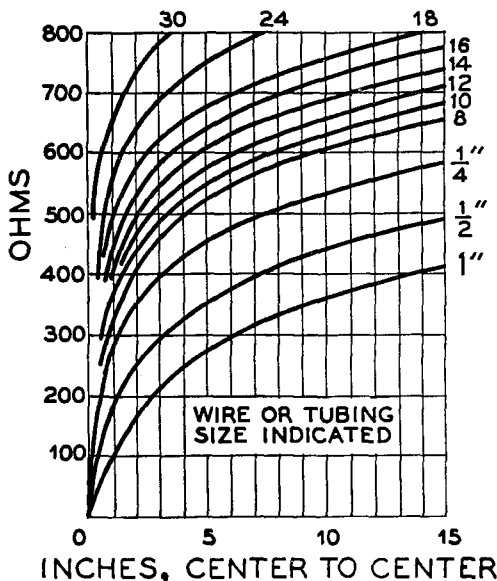

Figure 12.
CONDUCTOR SIZE AND SPACING VERSUS SURGE IMPEDANCE FOR TWO-WIRE OPEN LINE OR MATCHING TRANSFORMER.

Twisted-Pair Untuned Lines. Low-loss, low-impedance transmission cable, marketed by several manufacturers under the trade name of "EO1 cable," allows a very flexible transmission line system to be used to convey energy to the antenna from the transmitter. The low-loss construction is largely due to the use of untinned solid conductors, low-loss insulation, plus a good grade of weatherproof covering.

Twisted no. 12 or no. 14 outside house wire may be used on 160 and 80 meters if the length is not over 50 or 75 feet. On higher frequencies, however, the losses with such "homemade" twisted line will be excessive.

A twisted-pair line should always be used as an untuned line, as standing waves on the line will produce excessive losses and can easily break down the line insulation at the voltage loops.

For turning sharp corners and running close to large bodies of metal, the twisted pair is almost as good as the lower frequencies as the coaxial line.

Above 14 Mc., however, the rubber insulation causes appreciable dielectric loss even with the best EO1 cable, and the twisted-pair type of low-impedance line should not be used except where the length is short or where more efficient lines might not be suit-

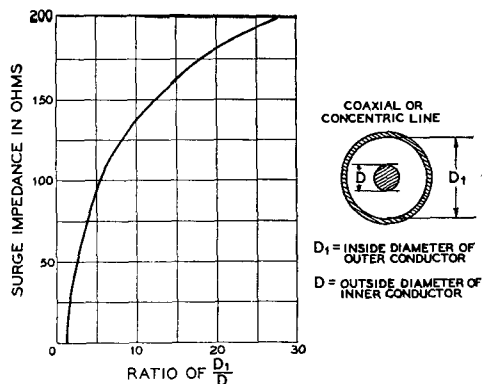

Figure 13.

CURVE FOR DETERMINATION OF SURGE IMPEDANCE OF ANY COAXIAL LINE HAVING AIR DIELECTRIC.

Presence of spacing insulators will lower the impedance somewhat below the calculated value as derived from this chart.

able from a mechanical standpoint, as in certain types of rotary arrays.

The low surge impedance of the twisted-pair transmission line is due not only to the close spacing of the conductors, but to the rubber insulation separating them. The latter has a dielectric constant considerably higher than that of air. This not only lowers the surge impedance but also results in slower propagation of a wave along the conductors. As a result the voltage loops occur closer together on the line when standing waves are present than for an open-wire line working at the same frequency.

Coaxial Line. Several types of coaxial cable have come into wide use for feeding power to an antenna system. A cross-sectional end view of a coaxial cable (sometimes called concentric cable or line) is shown in figure 13.

As in the parallel-wire line, the power lost in a properly terminated coaxial line is the sum of the effective resistance losses along the length of the cable and the dielectric losses between the two conductors. In a well designed line using air or nitrogen as the dielectric, both are negligible, the actual measured loss in a good line being less than 0.5 db per 1000 feet at one megacycle.

Of the two losses, the effective resistance loss is the greater; since it is largely due to the skin effect, the line loss (all other conditions the same) will increase directly as the square root of the frequency.

COMPARATIVE R. F. FEEDER LOSSES		
FREQUENCY	DB LOSS PER 100 FT.	TYPE OF LINE
7 Mc.	0.9	150-ohm impedance, rubber insulated twisted-pair with outer covering of braid.
14 Mc.	1.5	
30 Mc.	3	
7 Mc.	0.4	W. E. $\frac{3}{8}$ " concentric pipe feeder with inner wire on bead spacers. Impedance, 70 ohms.
30 Mc.	0.9	
7 Mc.	0.05	Open 2-wire line no. 10 wire. Impedance, 440 ohms.
30 Mc.	0.12	
7 Mc.	3	Twisted no. 14 solid weatherproof wire, weathered for six months (telephone wire).
14 Mc.	4½	
30 Mc.	8	

Figure 13 shows that, instead of having two conductors running side by side, one of the conductors is placed *inside* of the other. Since the outside conductor completely shields the inner one, no radiation takes place when the outside cable is grounded. The conductors may both be tubes, one within the other, or the line may consist of a solid wire within a tube.

In one type of cable (solid or semi-flexible low-loss type) the inner conductor is supported at regular intervals from the outside tube by a circular insulator of either pyrex, polystyrene, or some non-hygroscopic ceramic material with low high frequency losses. The insulators are slipped over the inner conductor and held in place either by some system of small clamps or by crimping the wire immediately in front of and behind each insulator.

Moisture must be kept out of the tube if best results are to be secured. For this reason it is necessary to solder or otherwise to join tightly the line sections together so that no leak occurs. This prevents water from seeping into the line in outdoor installations.

To avoid condensation of moisture on the inside walls of the line, it is the general practice to fill the line with dry nitrogen gas at a pressure of approximately 35 pounds per square inch.

Filling a line with dry nitrogen gas also greatly increases its power capacity, a power capability rating of three to one being quite common for the nitrogen-filled line as compared to a line operating under normal atmospheric pressures.

Nearby metallic objects cause no loss and the cable can be run up air ducts, wire conduit or elevator shafts. Insulation troubles can

be forgotten. The coaxial cable may be either buried in the ground or suspended above ground.

Highly flexible coaxial cable having continuous rubber dielectric for maintenance of spacing and an outer conductor of shield braid of the type used for ordinary shielded wire has become quite popular among amateurs for certain applications. Because of the rubber dielectric, the losses are about the same as for EO1 cable on the higher frequencies, while on the lower frequencies (below 4000 kc.) the losses are nearly as low as for the air-dielectric type of coaxial line.

The chief advantage of rubber dielectric coaxial cable over EO1 cable is its availability in lower values of surge impedance, making it possible to feed Marconi antennas and certain types of low radiation resistance arrays without need for an impedance matching device. Twisted-pair cable is not commonly available with a surge impedance of less than 70 ohms, while rubber dielectric coaxial cable is available with a surge impedance of as low as 28 ohms.

Coaxial cable, like twisted-pair cable, is most commonly used without a matching system. Cable is chosen to have a surge impedance that approximates the terminal radiation resistance of the antenna (point at which the line is connected).

While coaxial cable is best suited to use with Marconi antennas, because the outside conductor is ordinarily grounded, it can be used successfully to feed a balanced dipole. This is permissible because the impedance is low and therefore no great unbalance results from each operation. The outer conductor of the coaxial cable connects to one half the dipole and the inner conductor connects to the other half. In this case the outer conductor is often left ungrounded.

Matching Nonresonant Lines to the Antenna

From the standpoint of economy and efficiency, the most practical untuned line is an open line having a surge impedance of from 440 to 600 ohms. Unfortunately, it is seldom that the antenna system being fed has an impedance of similar value either at a current loop or at a voltage loop. It is sometimes necessary with current-fed antennas to match the line to an impedance as low as 8 or 10 ohms, while with voltage-fed antenna systems and arrays it is occasionally necessary to match the line to an impedance of many thousands of ohms. There are many ways of ac-

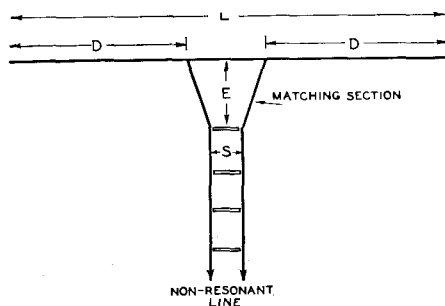

Figure 14.
THE DELTA-MATCHED ANTENNA SYSTEM.

This system is sometimes called a "Y matched" doublet. For dimensions refer to formula in text.

complishing this, the more common and most satisfactory methods being discussed here.

Delta-Matched Antenna System. The delta type matched-impedance antenna system is quite widely used. Figure 14 shows this feeder system. The impedance of the transmission line is transformed gradually into a higher value by the fanned-out Y portion of the feeders, and the Y portion is tapped on the antenna at points where the antenna impedance is a compromise between the impedance at the ends of the Y and the impedance of the unfanned portion of the line.

The constants of the system are rather critical, and the antenna must resonate at the operating frequency in order to minimize standing waves on the line. Some slight readjustment of the taps on the antenna is desirable if appreciable standing waves persist in appearing on the line. It is almost impossible to get the standing wave ratio below 2/1 with this system, and as standing waves of this order are not objectionable on an open line if it is cut to such a length that it is non-reactive, this ratio is considered as indicating the best match that can be expected with a "Y" or delta-matched doublet.

The constants are determined by the following formulas:

$$L_{\text{feet}} = \frac{467.4}{F \text{ megacycles}}$$

$$D_{\text{feet}} = \frac{175}{F \text{ megacycles}}$$

$$E_{\text{feed}} = \frac{147.6}{F \text{ megacycles}}$$

where L is antenna length; D is the distance in from each end at which the Y taps on; E is the height of the Y section.

As these constants are correct only for a 600-ohm transmission line, the spacing S of the line must be approximately 75 times the diameter of the wire used in the transmission line. For no. 14 B & S wire, the spacing will be slightly less than 5 inches. For no. 12 B & S, the spacing should be 6 inches. This system should never be used on either its even or odd harmonics as entirely different constants are required when more than a single

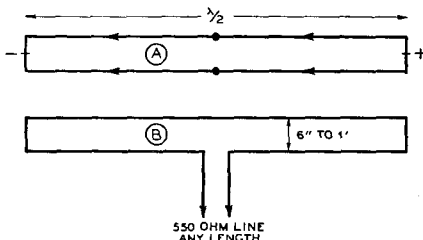

Figure 15.

Kraus version of the two-wire doublet. The antenna has high radiation resistance and permits use of an open-wire line without need for a matching system. Arrows indicate direction of current flow at any instant; dots indicate location of current loop.

half wavelength appears on the radiating portion of the system.

The Multi-Wire Doublet. When a doublet consists of two or more wires instead of the more usual single wire, the radiation resistance (impedance at the current loop) is raised. This is due to the fact that each wire tends to induce an opposing current in the opposite wire, but cannot because the two wires are tied together at either end. See "A," figure 15.

If we split just one wire of such an antenna, as at "B" in figure 15, and feed the antenna at this point, we find that the terminal radiation resistance is much higher than the theoretical 72 ohms of a conventional doublet. The terminal radiation resistance is the impedance into which the feed system works. Because each wire of the two-wire doublet carries half the total current and the feed line serves only one wire, the

terminal radiation resistance is four times the radiation resistance of the antenna taken as a whole, which already is higher than that of a regular doublet.

The terminal radiation resistance of a two-wire doublet such as that of "B" when well removed from earth is about 300 ohms. This means that we can use an ordinary 500 to 600 ohm open line to feed the antenna directly, without need for a matching system. When used with a 500-ohm line (no. 12 spaced 4 inches) the standing waves will be quite low (approximately 2/1 ratio) over a range in frequency of several per cent either side of resonance. The broad tuning characteristic is a result of the high radiation resistance.

The magnitude of standing waves with this system when using the feed line specified will result in standing waves comparable to the average Q matched single-wire doublet (described on page 414) and somewhat better than the delta-matched doublet.

The spacing of the two wires is not at all critical, and need not be exactly uniform just so the system is symmetrical. The overall length of the "loop" is just twice that of a regular doublet wire. Just subtract the wire spacing from the customary doublet length for the same frequency to obtain the correct length for each of the two elements, and split the lower element in the exact center.

Single Wire Fed Antenna. If one wire is removed from the delta matched impedance antenna of figure 14 and the remaining feeder is moved along the doublet to the point giving the lowest standing wave ratio on the single feed wire, the system will still work satisfactorily. However, there will be an appreciable amount of radiation from the feeder even with the best possible match, and for this reason a single wire feeder is never used to feed directive antenna arrays and is used primarily for portable and emergency work.

A single-wire feed line has a characteristic surge impedance of from 500 to 600 ohms, depending upon the diameter of the feeder wire. This type feeder makes use of the earth as a return circuit through the earth's capacity effect to the antenna and feeder. The actual earth connection to the transmitter may have a relatively high resistance without causing appreciable loss of r.f. energy. It may even be represented by the capacity of the transmitter and house wiring to earth.

The feeder is normally attached to the radiator about 1/6 or 1/7 of a half wavelength from the center.

The single wire fed antenna works well not only on its fundamental, but is a good radiator on its various harmonics. For this

reason this type antenna system should not be used on the low and medium frequency bands unless a harmonic suppressing antenna coupler is used to prevent radiation of harmonics.

A single wire feeder also can be used to feed a quarter wave vertical Marconi radiator. The best point of attachment for the feeder should be determined by cut and try. Normally it will be about 1/3 of the way up the radiator.

Matching Stubs

It is possible to hang a resonant length of Lecher wire line (called a matching stub) from either a voltage or current loop and attach 600-ohm nonresonant feeders to the resonant stub at a suitable voltage (impedance) point. The stub is made to serve as an auto-transformer. Thus, by putting up a half-wave zep with quarter-wave feeders at a distance from the transmitter and attaching a 600-ohm line from the transmitter to the zep feeders at a suitable point, we have a stub-matched antenna. The example cited here is commonly called a J antenna, especially when both radiator and stub are vertical. Many variations from this example are possible; stubs are particularly adapted to matching an open line to certain directional arrays as will be described later in this chapter.

Voltage Feed. When the stub attaches to the antenna at a voltage loop, the stub should be a quarter wavelength long electrically and be shorted at the bottom end. The stub can be resonated by sliding the shorting bar up and down before the nonresonant feeders are attached to the stub, the antenna being shock-excited from a separate radiator during the process. Slight errors in the length of the radiator can be compensated for by adjustment of the stub if both sides of the stub are connected to the radiator in a symmetrical manner. Where only one side of the stub connects to the radiating system, as in the J antenna example given here, the radiator length must be exactly right in order to prevent excessive unbalance in the untuned line.

If only one leg of a stub is used to voltage-feed a radiator, it is impossible to secure a perfect balance in the transmission line due to a slight inherent unbalance in the stub itself when one side is left floating. This unbalance, previously discussed under the *zepp antenna system*, should not be aggravated by a radiator of improper length.

Current Feed. When a stub is used to current-feed a radiator, the stub should either

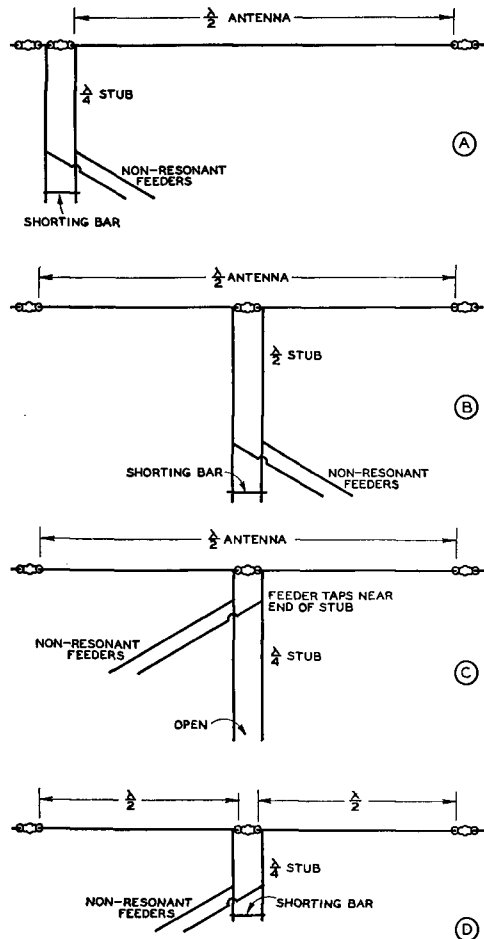

Figure 16. MATCHING-STUB APPLICATIONS.

- (A) Half-wave antenna with quarter-wave matching stub.
- (B) Center-fed half-wave antenna with half-wave matching stub.
- (C) Center-fed half-wave antenna with stub line cut to exact length without shorting bar.
- (D) Two half-wave sections in phase with quarter-wave stub.

be left *open* at the bottom end instead of shorted or else made a *half wave* long. The open stub should be resonated in the same manner as the shorted stub before attaching the transmission line; however, in this case, it is necessary to prune the stub to resonance as there is *no shorting bar*.

Sometimes it is handy to have a stub hang from the radiator to a point that can be reached from the ground in order to facilitate

adjustment of the position of the transmission-line attachment. For this reason, a quarter-wave stub is sometimes made three-quarters wavelength long at the higher frequencies in order to bring the bottom nearer the ground. Operation with any *odd* number of quarter waves is the same as for the quarter-wave stub.

Any number of *half waves* can be added to either a quarter-wave stub or a half-wave stub without disturbing the operation though losses will be lowest if the shortest usable stub is employed. This can be fully understood by inspection of the accompanying table.

Stub Length (Electrical)	Current-Fed Radiator	Voltage-Fed Radiator
$\frac{1}{4}$ - $\frac{3}{4}$ - $1\frac{1}{4}$ -etc. wavelengths	Open	Shorted
$\frac{1}{2}$ - 1 - $1\frac{1}{2}$ - 2 -etc. wavelengths	Shorted	Open

Shorted-Stub Tuning Procedure. When the antenna requires a shorted stub (odd number of quarter waves if the antenna is voltage-fed; even number of quarter waves if radiator is current-fed), the tuning procedure is as follows:

Shock-excite the radiator (or one of the half-wave sections if harmonically operated) by means of a makeshift doublet strung directly underneath where possible and just off the ground a few inches, connected to the transmitter by means of any kind of twisted pair or open line handy.

With the feeders and shorting bar disconnected from the stub, slide along an r.f. milliammeter or low-current dial light at about where you calculate the shorting bar should be and find the point of maximum current (in other words, use the meter or lamp as a shorting bar).

Make sure it is impossible for plate voltage to be on the feed line before attempting this procedure. *Inductive coupling to the final amplifier by means of a few turns of high tension ignition wire is recommended during any tuning up process where the operator must come in contact with the antenna or feeders.*

It is best to start with reduced power to the transmitter until you see how much of an indication you can expect; otherwise, the meter or lamp may be blown on the initial trial. The leads on the lamp or meter should be no longer than necessary to reach across the stub.

After finding the point of maximum current, remove the lamp or meter and connect a piece of wire across the stub at that point.

Starting at a point about a quarter of a quarter wave (8 feet at 40 meters) from the shorting bar, connect the feeders to the stub. Then, move the feeders up and down the stub until the standing waves on the line are at a minimum. The makeshift doublet should, of course, be disconnected and the regular feeders connected to the transmitter instead during this process. Slight readjustment of the shorting bar will usually result in further improvement.

When checking for standing waves, take readings no closer than several feet to the stub as the proximity of the stub will affect the reading of the standing wave indicator and lead one to false conclusions. The standing wave indicator may be either a voltage device, such as a neon bulb, or a current device, such as an r.f. milliammeter connected to a pickup coil. A high degree of accuracy is not required.

The following rule will indicate in which direction the feeders should be moved in an attempt to minimize standing waves: If the current increases on the transmission line as the indicator is moved away from the point of attachment to the stub, the feeders are attached too far from the shorting bar, and must be moved closer to the shorting bar. If the current decreases, the feeders must be attached farther from the shorting bar.

Open-Ended Stub Tuning Procedure. If the antenna requires an open stub (even number of quarter waves if the antenna is voltage-fed; odd number of quarter waves if radiator is current-fed), the tuning procedure is as follows:

Shock-excite the radiator as described for tuning a shorted-stub system, feeders disconnected from the stub and stub cut slightly longer than the calculated value. Place a field strength meter [the standing wave indicator can be very easily converted into one by addition of a tuned tank] close enough to one end of the radiator to get a reading, and as far as possible from the makeshift exciting antenna. Now, start folding and clipping the stub wires back on themselves a few inches at a time, effectively shortening their length, until you find the peak as registered on the field meter.

Now, attach the feeders to the stub as described for the shorted-stub system, but, for the initial trial connection, the feeders will attach at a distance more nearly three-quarters of a quarter wave from the end of

the stub instead of a quarter of a quarter wave as is the case for a shorted stub. After attaching the feeders, move them along the stub as necessary to minimize standing waves on the line. If sliding the feeders along the stub a few inches makes the standing waves worse, it means the correct connecting point is in the other direction.

After the optimum point on the stub is found for the feeder attachment, the length of the stub can be "touched up" for a final adjustment to minimize standing waves. This is advisable because the attachment of the feeder often detunes the stub slightly, as will be explained.

Important Note on Stub Adjustment.

When a stub is used to match a line to an impedance of the same order of impedance as that of the surge impedance of the stub and line (assuming the stub and line use the same wire size and spacing) it will be found that attaching the feeders to the stub introduces a large amount of reactance. The length of the stub then must be altered considerably to restore resonance.

Unfortunately, alteration of the stub length requires that the position of attachment of the feeders be readjusted. Consequently, the adjustment entails considerable juggling of both stub length and point of feeder attachment in order to minimize both reactance and standing waves.

If a *shorted* stub is used to feed an impedance of more than 3 times that of the surge impedance of the stub and line, this effect will be negligible, and it is not absolutely necessary that the stub length be readjusted after the feeders are attached. Likewise the length of an *open* stub need not be altered after attachment of the feeders if the stub feeds an impedance of less than 1/3 that of the surge impedance of the stub and line.

As a practical example, this means that if a 600-ohm line and shorted stub are used to feed an impedance of more than 1800 ohms, the length of the stub need not be readjusted after the feeders are attached (in order to eliminate objectionable reactance). If the stub feeds an impedance of less than 1800 ohms, attachment of the feeders to the stub will detune the stub appreciably, making readjustment of the stub length absolutely necessary.

When not sure of the exact order of impedance into which the stub works, it is always advisable to try "touching up" the stub length after the feeders are attached.

Standing Wave Indicators. Many simple devices can be used for detecting the presence

Frequency in Kilocycles	Quarter-wave matching section or stub	Half-wave radiator
3500	70'3"	133'7"
3600	68'5"	129'10"
3700	67'6"	126'4"
3800	64'10"	123'
3900	63'1"	119'10"
3950	62'3"	118'4"
4000	61'6"	116'10"
7000	35'1"	66'9"
7150	34'5"	65'4"
7300	33'8"	64'
14,000	17'7"	33'5"
14,200	17'4"	32'11"
14,400	17'1"	32'6"
28,000	8'9"	16'8"
28,500	8'7"	16'5"
29,000	8'6"	16'1"
29,500	8'4"	15'10"
30,000	8'2"	15'7"

DIMENSIONS FOR HALF-WAVE RADIATOR AND QUARTER-WAVE MATCHING STUB OR Q SECTION.

Dimensions for 1750-2000 kc. may be determined from lengths for 3500-4000 kc. A 2000-kc. radiator or matching transformer is just twice as long as one for 4000 kc.

and approximate ratio of standing waves on a feed line. A one turn pickup loop, about 4 or 5 inches in diameter, may be attached to a current indicator such as a small Mazda bulb or an r.f. thermogalvanometer to indicate current excursions along the line. The device should be attached to the end of a wood stick at least a foot long in order to minimize body capacity. The loop is moved along the line in inductive relation to the feed line, care being taken to see that the loop always is in *exactly the same inductive relation* to the line. It should be kept in mind that this type of indicator is a *current* indicator.

A small neon bulb also may be used to indicate standing waves on a feed line. In this case the indicator works on *voltage*, and it should be kept in mind that the voltage on the line normally is highest where the current is lowest. This type of indicator is operated by touching various parts of the bulb to *one* feeder wire until an indication of medium brilliancy is obtained. The bulb is then slid along the wire, *in exactly the same position and point of contact with the wire*. If the enamel insulation is not intact on all portions of the wire and the wire is exposed in spots, deceptive "bumps" will be noticed. The wire should be either uniformly insulated or uniformly bare throughout its length, other-

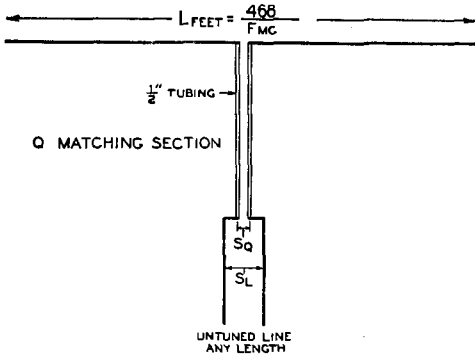

Figure 17.

METHOD OF FEEDING A HALF-WAVE RADIATOR BY MEANS OF Q BARS. REFER TO TABLES FOR DIMENSIONS.

CORRECT VALUES OF SURGE IMPEDANCE OF $\lambda/4$ MATCHING SECTIONS FOR DIFFERENT LENGTHS OF ANTENNAS.

Antenna Length in Wavelength	Surge Impedance for Connection Into Two-Wire Open Lines with Impedance of	
	500 Ohms	600 Ohms
1/2	190	212
1	210	235
2	235	257
4	255	282
8	280	305

Matching section connects into center of a current loop, such as middle of a half-wave section.

wise it will be necessary to place a thickness of insulating material over the exposed metal parts of the neon bulb, the bulb then working by virtue of capacity to the wire rather than direct contact.

If it is desired to measure the exact rather than relative standing wave ratio and an r.f. meter is not available, a low range d.c. milliammeter may be used instead if a suitable rectifier is placed in series with the d.c. meter. A 0-1 ma. d.c. milliammeter in series with a carborundum crystal rectifier is commonly used. As noted before, this type of indicator is a *current* indicator.

Linear R. F. Transformers

Q-Matching Section. A resonant quarter-wave line has the unusual property of acting much as a transformer. Let us take, for example, a quarter-wave section consisting of no. 12 wire spaced six inches, which happens to have a surge impedance of 600 ohms. Let the far end be terminated with a pure resistance and let the near end be fed with radio-frequency energy at the frequency for which each feeder is a quarter wavelength long. If an impedance measuring set is used to measure the impedance at the near end while the impedance at the far end is varied, an interesting relationship between the 600-ohm characteristic surge impedance of this particular quarter-wave matching line and the impedance at the two ends will be discovered.

When the impedance at the far end of the line is the same as the characteristic surge impedance in the line itself (600 ohms), the

impedance measured at the near end of the quarter-wave line will also be found to be 600 ohms.

Under these conditions, the line would not have any standing waves on it due to the fact that it is terminated in its characteristic impedance. Now, let the resistance at the far end of the line be doubled, or changed to 1200 ohms. The impedance measured at the near end of the line will be found to have been cut in half and is now 300 ohms. If the resistance at the far end is made half the original value of 600 ohms, or 300 ohms, the impedance at the near end doubles the original value of 600 ohms and becomes 1200 ohms. Therefore, as one resistance goes up, the other goes down proportionately.

It will always be found that the characteristic surge impedance of the quarter-wave matching line is the geometric mean between the impedance at both ends. This relationship is shown by the following formula:

$$Z_{MS} = \sqrt{Z_A Z_L}$$

where

Z_{MS} = Impedance of matching section.

Z_L = Antenna resistance.

Z_A = Line impedance.

Johnson-Q Feed System. The standard form of Johnson-Q feed to a doublet is shown in figure 17. An impedance match is obtained by utilizing a matching section the surge impedance of which is the geometric mean between the transmission line surge impedance and the radiation resistance of the radiator. A sufficiently good match can usually be obtained by either designing or adjusting the matching section for a dipole to have a surge impedance that is the geometric mean between the line impedance and 72 ohms, the latter being the theoretical radiation resistance of a half-wave doublet either infinitely high or a half wave above a perfect ground.

PARALLEL TUBING SURGE IMPEDANCE FOR MATCHING SECTIONS.

Center to Center Spacing in Inches	Impedance in Ohms for 1/2" Diameters	Impedance in Ohms for 1/4" Diameters
1	170	250
1.25	188	277
1.5	207	298
1.75	225	318
2	248	335

Though the radiation resistance may depart somewhat from 72 ohms under actual conditions, satisfactory results will be obtained with this assumed value so long as the dipole radiator is more than a quarter wave above effective earth and reasonably in the clear. The small degree of standing waves introduced by a slight mismatch will not increase the line losses appreciably, and any small amount of reactance present can be tuned out at the transmitter termination with no bad effects. If the reactance is objectionable, it may be minimized by making the untuned line an integral number of quarter waves long.

A Q-matched system can be adjusted precisely, if desired, by constructing a matching section to the calculated dimensions with provision for varying the spacing of the Q section conductors slightly, after the untuned line has been checked for standing waves.

The Q section will usually require about 200 ohms surge impedance when used to match a half-wave doublet, actually varying from about 150 to 250 ohms with different installations. This impedance is difficult to obtain with a two-wire line as very close spacing would be required. For this reason either a four-wire line or a line consisting of two half-inch aluminum tubes is ordinarily used. The four-wire section has the advantage of lightness and cheapness, and can be used where the approximate radiation resistance is known with certainty, thus making it possible to design the matching section for a certain value of surge impedance with some assurance that it will turn out to be sufficiently accurate.

The apparent complexity of the Q-matched dipole comes from the large number of antennas and line combinations which the Q section is able to match.

The untuned transmission line between the transmitter and the input, or lower end of the Q section, can be any length (within reason).

Q System with Four-Wire Transformer.
The reduction in impedance obtained by the

Z ₀ OHMS	№ 12 WIRE			№ 14 WIRE		
	COL. 1 SPACING INCHES	COL. 2 SPACING INCHES	COL. 3 CIR. DIA INCHES	COL. 4 SPACING INCHES	COL. 5 SPACING INCHES	COL. 6 CIR. DIA INCHES
175	1.415	1 1/8	2.001	1.120	1 1/8	1.585
184	1.495	1 1/2	2.110	1.185	1 3/16	1.675
187	1.535	1 3/16	2.175	1.215	1 1/4	1.720
193	1.630	1 5/8	2.305	1.280	1 5/16	1.820
200	1.720	1 3/4	2.434	1.361	1 3/8	1.935
202	1.820	1 13/16	2.560	1.440	1 7/8	2.100
203						
206	2.020	2	2.858	1.600	1 5/8	2.261
207						
210						
211	2.120	2 1/8	3.000	1.630	1 11/16	2.378
212						
216	2.301	2 5/8	3.122	1.825	1 13/16	2.581
219	2.420	2 7/8	3.421	1.920	1 15/16	2.719
223						
224	2.662	2 11/8	3.700	2.110	1 1/8	2.890
225						
228	2.910	2 15/16	4.110	2.310	2 5/16	3.375
232	3.075	3 1/16	4.350	2.435	2 7/16	3.440
234	3.150	3 1/8	4.450	2.497	2 1/2	3.530
238	3.320	3 5/16	4.690	2.625	2 5/8	3.720
240	3.420	3 7/16	4.835	2.721	2 11/16	3.853
245	3.640	3 5/8	5.150	2.881	2 7/8	4.075
250	4.040	4 1/8	5.710	3.204	3 3/8	4.540
256	4.360	4 3/8	6.160	3.460	3 7/8	4.890
261	4.650	4 5/8	6.580	3.683	3 11/16	5.202

Figure 18.
FOUR-WIRE MATCHING SECTION DESIGN TABLE.

use of four conductors instead of two makes the four-wire line highly useful for matching transformer applications. For instance, the order of impedance ordinarily required for Q-matching sections is easily obtained by spacing four wires around a circular insulating spacer of suitable diameter.

Plastic iced-tea coasters of suitable diameter can be used for spacers. The usual dime store price is five cents each. When purchasing the coasters, one should take precaution to get the correct type of material. It seems that some are made from bakelite, while others are made of a plastic that has much better high frequency insulation qualities than bakelite. The plastic ones can easily be identified: they are translucent, while the bakelite ones are not.

The line is flexible and must be used under slight tension to keep the wires from twisting. Spacers should be placed approximately every two feet. The diagonally opposite wires should be connected together at each end of the four-wire section.

Exact dimensions for the 4-wire type Q section for common surge impedances are given in figure 18. The length of the section is the same as for the two-conductor type.

OPERATING AN ANTENNA ON ITS HARMONICS

Zepp-fed, single-wire-fed, and direct-fed antennas have always been the most popular antennas for multi-band operation. This is due to the fact that practically all of the antennas that are fed by two-wire non-resonant transmission lines reflect a bad mismatch into the line when operated on two, four or eight times the fundamental antenna frequency. Thus, the twisted-pair doublet, the Johnson Q, the matched-impedance J or T types, all are unsuitable for even-harmonic operation.

The radiating portion of an antenna does not resonate on integral harmonics of its fundamental frequency. It is a common assumption that a half-wave antenna cut, for example, for 3500 kc. (133' 7") resonates on all the integral harmonics of 3500 kc. and, thus, can be used on 7000, 14,000 and 28,000 kc. Actually, a half-wave antenna cut for 3500 kc. resonates at 7182, 14,553 and 29,312 kc. These frequencies are related by the formulas

$$L = \frac{492 (K-.05)}{F_{Mc}}$$

$$F_{Mc} = \frac{492 (K-.05)}{L}$$

Where F equals frequency in *megacycles*. L equals length in feet.

K equals number of half waves on wire.

These formulas are accurate for all frequencies between 1800 and 30,000 kc.

It is sometimes desirable to determine the harmonic frequencies at which a given antenna wire resonates. This can be done very quickly if the fundamental frequency is known simply by referring to the following table:

Multiply fundamental frequency by

Fundamental or first harmonic...	1.000
Second harmonic	2.052
Third harmonic	3.106
Fourth harmonic	4.158
Eighth harmonic	8.375
Sixteenth harmonic	16.790

Thus, a wire which is a half wave-length long at 1000 kilocycles resonates on its second

harmonic at 2052 kc.; third harmonic at 3106 kc., etc.

The table can also be used to determine what length to cut a harmonic radiator for operation on a given frequency. Look up the correct length for a half-wave doublet for that frequency and multiply the length by the factor given here for the harmonic on which you wish to work. Thus a third harmonic 14,000-ke. antenna is just 3.106 times as long as a 14,000-ke. doublet.

When designing an antenna for operation on more than one band, it should be cut for harmonic resonance at its highest operating frequency. If it is to be operated off resonance on some band, it is better to have it off resonance on a low frequency band because any errors then become a smaller percentage of a half wave.

COUPLING TO THE TRANSMITTER

When coupling either an antenna or antenna feed system to a transmitter, the important considerations are as follows: (1) means should be provided for varying the load on the amplifier, (2) the two tubes in a push-pull amplifier should be equally loaded, (3) the load presented to the final amplifier should be nonreactive; in other words, it should be a purely resistive load.

The first item is often referred to as "matching the feeder impedance to the transmitter" or "matching the impedance." It is really a matter of *loading*. The coupling is increased until the final amplifier draws the correct plate current. Actually, all the matching and mismatching we worry about pertains to the junction of the feeders and *antenna*.

The matter of equal load on push-pull tubes can be taken care of by simply making sure that the coupling system is symmetrical, both physically and electrically. For instance, it is not the best practice to connect a single-wire feeder directly to the tank coil of a push-pull amplifier.

The third consideration, that of obtaining a nonreactive load, is important from the standpoint of efficiency, radiated harmonics, and voice quality in the case of a phone transmitter. If the feeders are clipped directly on the amplifier plate tank coil, either the surge impedance of the feeders must match the antenna impedance perfectly (thus avoiding standing waves) or else the feeders must be cut to exact resonance.

If an inductively-coupled auxiliary tank is used as an antenna tuner for the purpose of

adjusting load and tuning out any reactance, one need not worry about feeder length or complete absence of standing waves. For this reason, it is always the safest procedure to use such an antenna coupler rather than connect directly to the plate tank coil.

Function of an Antenna Coupler. The function of an output coupler is to transform the impedance of the feed line, or the antenna, into that value of plate load impedance which will allow the final amplifier to operate most effectively. The antenna coupler is, therefore, primarily an impedance transformer. It may serve a secondary purpose in filtering out harmonics of the carrier frequency. It may also tune the antenna system.

Practically every known antenna coupler can be made to give good results when properly adjusted. Certain types are more convenient to use than others, and the only general rule to follow in the choice of an antenna coupler is to use the simplest one that will serve your particular problem.

There is practically nothing that an operator can do at the station end of a transmission line that will either increase or decrease the standing waves on the line, as that is entirely a matter of the coupling between the line and the antenna itself. However, the coupling at the station end of the transmission line has a very marked effect on the efficiency and the power output of the final amplifier in the transmitter. Whenever we adjust antenna coupling and thus vary the d.c. plate current on the final amplifier, all we do is vary the ratio of impedance transformation between the feed line and the tube plate (or plates).

Coupling Methods. Figure 19 shows several of the most common methods of coupling between final amplifier and feed line.

The fixed condenser C_a is a large capacity mica condenser in every case. It has no effect upon tuning or operation; it is merely a blocking condenser keeping high voltage d.c. off the transmission line.

Capacitive Coupling. Figure 19A shows a simple method of coupling a single-wire non-resonant feeder to an unsplit plate tank. The coupling is increased by moving the tap away from the voltage node and toward the plate end of the plate tank coil. Either the center or the bottom end of the coil may be by-passed to ground.

The system shown in figure 19B shows a means of coupling an untuned two-wire line to a split plate tank. If it is desired to couple a two-wire untuned line to an unsplit plate tank, it will be necessary to use some form of inductive coupling. See figure 19E.

The circuit of figure 19C shows a π -section filter coupling an unsplit tank to any end-fed antenna or single-wire line. Figure 19D shows the two-wire version of the π -section coupler, sometimes called the *Collins* coupler.

Inductive Coupling. Inductive coupling methods may be classified in two types: direct inductive coupling and link coupling. Direct inductive coupling has been very popular for years, but link coupling between the plate tank and the antenna coupler proper is usually more desirable. Figure 19E shows inductive coupling to an untuned two-wire line. This same arrangement can be used to couple from a split plate tank to a single-wire untuned feeder by grounding one side of the antenna coil.

The circuit shown in figure 18F is the conventional method of coupling a zepp or tuned feed line to a plate tank circuit, but the arrangement shown in figure 19J is easier to adjust. Circuit shown in 19I is for coupling either a single or two-wire untuned feeder to either a split or unsplit plate tank circuit. The arrangement shown in figure 19K is easier to adjust. All coupling links anywhere in a transmitter should be coupled at a point of low r.f. potential to avoid undesired capacitive coupling.

Untuned low impedance lines of the twisted pair and coaxial types can best be coupled inductively by means of a one- or two-turn coupling link around the plate tank coil at the voltage node.

Tuning Pi-Section Filter. To get good results from the π -section antenna coupler, certain precautions must be followed. The ratio of impedance transformation in π networks depends on the ratio in capacity of the two condensers C_1 and C_2 (figure 19C and D).

The first step in tuning is to disconnect the π -section coupler from the plate tank entirely. Then, apply low plate voltage and tune the plate tank condenser to resonance. Remove the plate voltage and tap the π -section connection or connections approximately halfway between the cold point on the coil and the plate or plates. Adjust C_2 to approximately half maximum capacity and apply plate voltage. Quickly adjust C_1 to the point where the d.c. plate current dips, indicating resonance.

At the minimum point in this plate current dip, the plate current will either be higher or lower than normal for the final amplifier. If it is lower, it indicates that the coupling is too loose; in other words, there is too high a ratio of impedance transformation. The plate current can be increased by *reducing* the

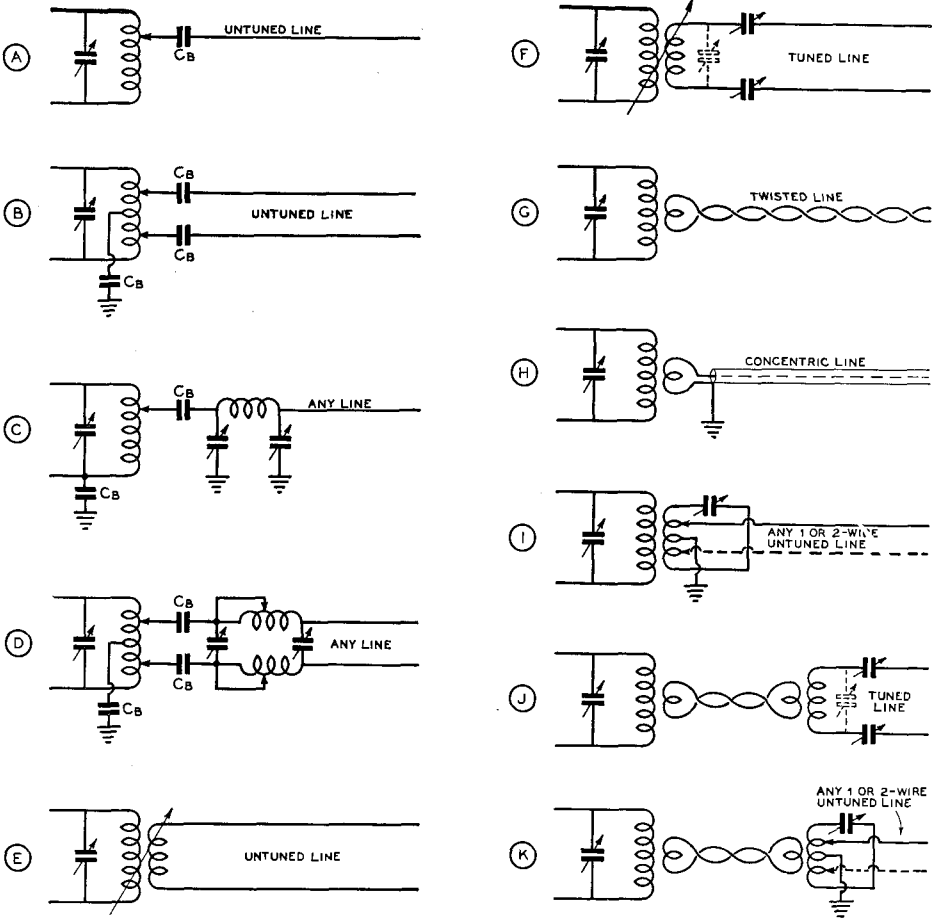

Figure 19.
COMMON METHODS OF COUPLING TRANSMISSION LINES TO THE OUTPUT TANK OF THE TRANSMITTER.

Balanced two-wire lines are assumed, whether of the resonant or "flat" (untuned) type. Coupling turns should always be placed around the "cold" portion of the coil; whether this is the center or end will be determined by whether the coil has one end grounded or is balanced to ground (center at ground r.f. potential). Tank tuning condensers can be split stator where balanced tanks are shown (center at low r.f. potential) without affecting operation of coupling circuit. C_B indicates mica blocking condenser to keep d.c. plate voltage off the feeder; these condensers should have a working voltage in excess of peak plate voltage and be at least .001 μ fd.

capacity of C_2 and then restoring resonance with condenser C_1 . At no time after the π -section coupler is attached to the plate tank should the plate tuning condenser be touched. If the d.c. plate current with C_1 tuned to resonance is too high, it may be reduced by increasing the capacity of C_2 in small steps, each time restoring resonance with condenser C_1 .

Should the plate current persist in being too high even with C_2 at maximum capacity,

it indicates either that C_2 has too low maximum capacity or that the π -section filter input is tapped too close to the plate of the final amplifier. If the plate current cannot be made to go high enough even with condenser C_2 at minimum capacity, it indicates that the input of the π -section is not tapped close enough to the plate end of the plate tank coil.

Mechanical Considerations. If inductive coupling to the final amplifier is contemplated, attention must be given to the mechanical or

physical considerations. Variable coupling is a desirable feature which facilitates correct loading of the amplifier. It is more easily incorporated if but a few turns are involved. This explains the popularity of link coupling methods (such as figure 19K) over directly coupled systems of the type illustrated in figure 19L. Untuned lines of 600 ohms or less, when operating correctly, seldom require more than a half dozen turns in the coupling link to provide sufficient coupling, especially on the higher frequency bands. Twisted-pair lines or coaxial cable may require only one or two turns. Marconi antennas (no feed line) may require anywhere from 1 to 10 turns, depending upon the frequency and radiation resistance.

Because sometimes the next integral turn provides too much coupling while without it there is insufficient coupling, it is necessary to provide means for obtaining coupling intermediate between that provided by integral turns. This can be done by adding the next integral turn and then either pulling the coupling coil away from the tank coil a little, or enlarging the turns so that the coupling coil does not fit snugly over the tank coil.

One very satisfactory method of providing continuously variable coupling calls for a set of split tank coils, with 1- or 1½-inch spacing between the two halves of the coils (depending upon diameter of the coils). A swinging coupling link, with sufficient tension or friction on the hinge to maintain the link in position after it has been adjusted, can be inserted between the two halves of the tank coil to give any degree of coupling desired. Manufactured coils can be obtained with this system of adjustable coupling. Another type manufactured coil is wound on a ceramic coil form with individual link turning inside the form on a shaft supported on bearings inserted in the form. The latter type requires two extra contacts on the coil jack bar.

If one uses the simpler method of pushing coupling turns down between the turns of the tank coil until sufficient coupling is obtained, high tension ignition cable is recommended if the plate voltage of more than 500 volts appears on the plate tank coil. Hookup wire or house wire is satisfactory for lower voltages.

The coupling link should never be placed at a point of high voltage on the tank coil. This means that the coupling link should be placed around the center of a split plate tank or near the "cold" end of an unsplit tank coil.

For a given number of turns in the coupling link, greatest coupling will occur when

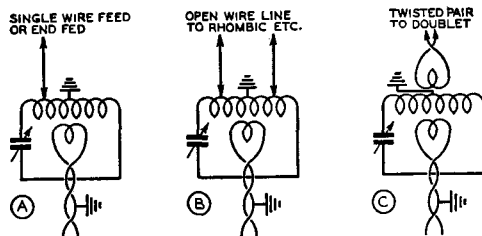

LINK COUPLING FROM SINGLE-ENDED OR P.P. R.F. AMPLIFIER

Figure 20.
SIMPLE METHODS OF HARMONIC SUPPRESSION WITH AN AUXILIARY TANK CIRCUIT.

the link is placed around the center of the coil, regardless of the location of the node on the coil. For this reason it is sometimes difficult to get sufficient coupling with an unsplit tank, as the link must be placed at the cold end of the coil in such a system to prevent detuning of the tank circuit, possible arcing between tank coil and link, and capacity coupling of harmonics.

On the higher frequencies it is important that superfluous reactance is not coupled into the line by a pick-up link having an excessive number of turns. This means that instead of using a 10 turn link on 28 Mc. to couple to a 72 ohm line and backing off on the coupling coil until the desired coupling is obtained, the number of turns should be reduced and the pick up coil coupled tighter to the tank coil. For this reason it is difficult to construct a swinging-link assembly having a single multi-turn coupling coil for coupling on all bands. With this type coupling, it usually will be found that if the pick up coil has sufficient turns to permit optimum coupling on 160 meters the coil will be so large that it will couple in an objectionable amount of reactance at 28 Mc. This assumes that the transmitter works into a line of the same surge impedance on all bands.

Suppressing Harmonic Radiation. Harmonics are present in the output of nearly all transmitters, though some transmitters are worse offenders in this respect than others. Those that are strong enough to be bothersome are usually the second and third harmonics.

Current-fed antennas, such as the twisted-pair-fed doublet and the Johnson Q-fed doublet, discriminate against radiation of the even harmonics. This is what keeps these antennas from being used effectively as all-band antennas. However, they are responsive

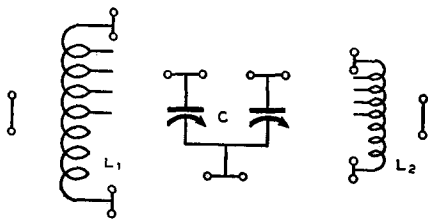

Figure 21.
CIRCUIT DIAGRAM OF THE UNIVERSAL
COUPLER.

The dots indicate heavy Fahnestock clips. For coil and condenser constants, see text.

to the *odd* harmonics, working about as well on the third harmonic as on the fundamental. For this reason, any third harmonic energy present in the output of the transmitter will be radiated unless a harmonic trap is used or other means taken to prevent it.

Most all-band antennas are responsive to both odd and even harmonics, and therefore are still worse as regards the possibility of harmonic radiation.

The delta-matched antenna, and radiators fed by means of a shorted stub and untuned line provide about the best discrimination against harmonics, but even these will radiate some third and other odd harmonic energy, and the odd harmonics always fall outside the amateur bands.

Best practice indicates the reduction of the amount of harmonic component in the transmitter output to as low a value as possible, then further attenuation between the transmitter and antenna *regardless of what antenna and feed system is used*. If you follow this practice you need not have fear of getting a citation from the Radio Inspector for harmonic radiation.

Three definite conditions must exist in the transmitter before harmonic radiation can take place. First, the final amplifier must either be generating or amplifying the undesired harmonics; second, the coupling system between the amplifier and the feeders or antenna system must be either capable of radiating them or transmitting them to the antenna, and third, the antenna system (or its feeders) must be capable of radiating this harmonic energy.

One effective method of reducing capacity coupling is through the use of a Faraday shield. The Faraday shield, however, offers no attenuation to anything but *capacity coupling* of the undesired energy. Since a great deal of the harmonic energy (the third and other odd harmonics) is *inductively* coupled

to the antenna system, an arrangement which will attenuate both capacitively and inductively coupled harmonics (both odd and even) would be desirable. A Faraday shield is not a cure-all. However, its performance is effective enough to warrant inclusion as standard equipment. Construction of a Faraday screen for a transmitting antenna is the same as for a receiving antenna, *Chapter Four*, except that it necessarily is larger.

A simple and very effective method of harmonic suppression is shown in figure 20. The link from the final tank to the antenna tank should consist of either a length of low impedance cable (EO1 or similar) or a *closely spaced* ($\frac{1}{2}$ inch) line of no. 12 or larger wire. This link should be loosely coupled by means of a single turn on 10, 20 and 40 meters (2 turns on 80 and 160 meters) at either end to both tank circuits. One side of the link should be effectively grounded near the final tank.

The antenna tank itself should be of medium C (a Q of about 10 or 12) at the operating frequency. At figure 20C the two links, the one to the final and the one to the antenna, should be spaced about two inches or so apart and at equal distances from the grounded center of the antenna coil. The balance of the diagram should be self-explanatory.

This coupling system operates by virtue of the fact that capacity coupling between the final tank and the antenna is eliminated by the grounded link and the grounded center tap of the antenna tank; also, due to the selectivity of the antenna tank against the harmonic frequencies, inductive coupling of them into the antenna system will also be attenuated.

In closing, a few general "don'ts" might be in order:

Don't use two tubes in parallel. Put them in push-pull if possible.

Don't use a doubler to feed an antenna unless it is of the push-push type. In a single-ended doubler, there is a high percentage of $\frac{1}{2}$ - and 2X output frequency present in the output tank.

Don't use more bias and excitation than necessary for reasonable efficiency or (in a phone transmitter) good linearity.

Don't use a 75-meter zepp on 160 meters, a 40-meter zepp on 80 meters, etc. Although it is usually the odd harmonics that are inductively coupled, in this case the second harmonic will be inductively coupled and elimination of capacity coupling will not remove the second harmonic.

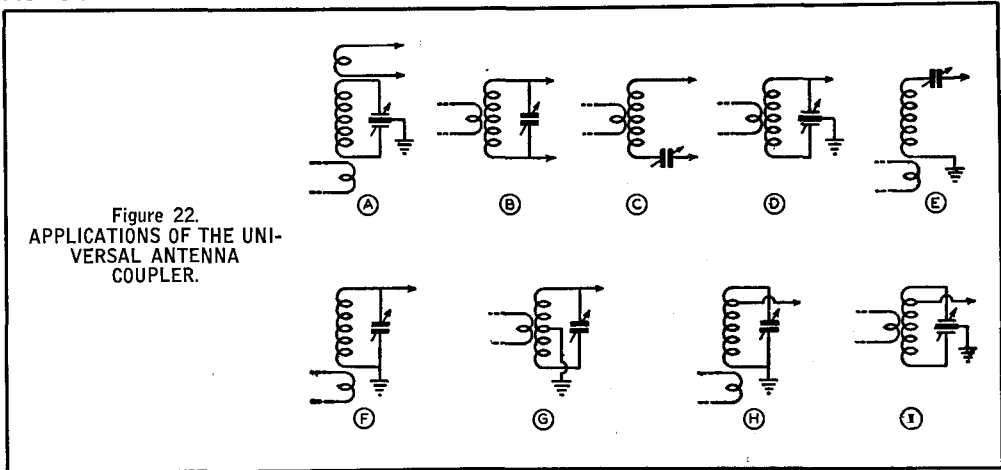

Don't use an all-band antenna unless you do not have room for separate antennas. If you must use such an antenna, use a harmonic-attenuating tank as shown in the accompanying diagrams.

Run a test with some local station close enough to give you an accurate check and see if your harmonics are objectionable.

A Simple Universal Coupler. A split-stator condenser of 200 $\mu\mu\text{fd.}$ or more per section can be mounted on a small board along with a large and a small multitapped coil to make a very useful and versatile antenna coupler and harmonic suppressor. With this unit it is possible to resonate and load almost any conceivable form of radiator and tuned feed system, and to adjust the loading and provide harmonic suppression with most any untuned transmission line. The circuit is shown in figure 21.

To facilitate connecting the coil and condenser combination in the many different ways possible, 12 large-size dual Fahnestock connectors are mounted on the coils and condenser terminals and generously scattered around. Two are mounted on standoff insulators to act as terminals for ground, antenna or other wires. A dozen lengths of heavy flexible wire of random lengths between 6 and 18 inches enable one to connect up the components in an almost infinite variety of combinations. Low-voltage auto ignition cable or heavy flexible hookup wire will do nicely.

Because under certain conditions and in certain uses both rotor and stator will be hot with r.f., an insulated extension is provided for the condenser shaft in order to remove the dial from the condenser by a few inches. This effectively reduces body capacity. It also precludes the possibility of being "bitten" by the dial set-screw.

The large coil consists of 30 turns of no. 12 wire, 4 inches in diameter and spaced to occupy $5\frac{3}{4}$ inches of winding space. The small coil consists of 14 turns, 2 inches in diameter, spaced to occupy $3\frac{1}{4}$ inches of winding space. Heavy duty 80- and 20-meter coils of commercial manufacture will serve nicely.

Both coils have taps brought out every other turn from one end to the center to facilitate clipping to the coils. A copper or brass clip is preferable to a steel clip for shorting out turns as the circulating current may be quite high.

Rather than short out too much of the large coil, we put the smaller coil into service. In fact, the two coils can even be used together in series should the large coil alone ever lack sufficient inductance for any purpose. However, for every common application, the large coil alone should possess sufficient inductance.

Now to cover some of the things we can do with this simple contraption:

At A in figure 22 the unit is used as a harmonic suppression tank as advocated earlier in this chapter.

Combination B may be used for either an end-fed or center-fed zapp that requires parallel tuning. It may also be used to feed an untuned open line, providing harmonic suppression. It may be used to tune an antenna counterpoise system that has a higher natural frequency than that upon which it is desired to operate. It may be used with any system utilizing tuned feeders where the system cannot be resonated with series tuning (see C).

Combination C may be used for either an end-fed or center-fed zapp that requires series tuning. It may be used to feed an antenna counterpoise system that is too long

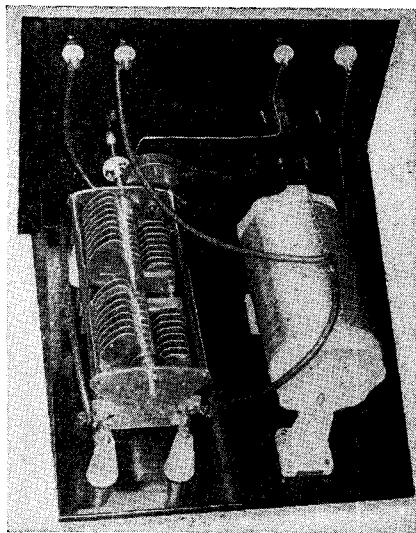

Figure 23.

UNIVERSAL ANTENNA COUPLER.

The unit shown above was designed for use only on the two lower frequency bands, hence the smaller coil (L_2 of figure 21) was omitted. An r.f. ammeter has been added for convenience in tuning.

electrically to resonate at the operating frequency at its natural period. It may be used with a multi-band antenna where the feeders are too long. It may be used for most any system utilizing tuned feeders where the system cannot be resonated using B.

Arrangement D may be used for feeding an end-fed antenna (even number of quarter waves long). It is usually preferable to F which is sometimes used for the same purpose.

System F also is used to tune a Marconi that is slightly shorter than an odd number of quarter waves long.

System E is the common method for tuning a Marconi where the antenna is slightly longer than an odd number of quarter waves.

G is commonly used to end-feed an antenna an even number of quarter waves long. It is a variation of D.

H and I are used for feeding either a single-wire-fed antenna or for end-feeding a very long-wire antenna (6 or more wavelengths long). For the latter purpose these are preferable to D, F and G.

In each case the link is coupled around the coil being used and one side of the twisted pair feeding the link is grounded.

Dummy Antennas

The law requires the use of some form of dummy antenna when testing a transmitter in order to minimize unnecessary interference.

The cheapest form of dummy antenna is an electric light globe coupled to the plate tank circuit by means of a four to eight turn pickup coil (or even clipped directly across a few turns of the tank coil). Another good form of dummy antenna that is relatively nonreactive is a bar of carbon tapped across enough of the tank turns to load the amplifier properly. The plaque (noninductive) types of wirewound resistors also are ideal for use as a dummy antenna load.

If a lamp or lamps are chosen of such value that they light up to approximately normal brilliancy at normal transmitter input, the output may be determined with fair accuracy by comparing the brilliancy of the lamps with similar lamps connected to the 110-volt line.

It is difficult to obtain a highly accurate measurement of the output by measuring the r.f. current through the light bulb and applying Ohm's law, because the resistance of the bulb cannot be determined with accuracy. The resistance of a light bulb varies considerably with the amount of current passing through the filament.

For highly accurate measurement of r.f. output, dummy antenna resistors having a resistance that is substantially constant with varying dissipation are offered in 100 watt and 250 watt ratings. These resistors are available in either 73 or 600 ohm types, and can be considered purely resistive at frequencies below 15 Mc. It will be noted that the two stock resistance values correspond to the surge impedance of the most common twisted-pair untuned line and the most common open-wire line respectively. This increases their usefulness.

These resistors are hermetically sealed in glass bulb containers, the latter containing a gas which accelerates the conduction of heat from the resistor element (filament) to the outer surface of the bulb. These resistors glow a dull red at full dissipation rating; though they somewhat resemble an incandescent lamp physically, they do not produce appreciable light. They may be used in series, parallel, or series parallel to get other resistance values or greater dissipation.

A correction chart is furnished so that one can correct for the slight non-linearity when a high degree of accuracy is required. With an r.f. ammeter of suitable range in series with the resistor, it is only necessary to note

the reading and refer to the chart to determine the exact amount of power being dissipated in the resistance.

DIRECTIVE ANTENNAS

No antenna except a single vertical element (no reflectors), radiates energy equally well in all directions. All horizontal antennas have directional properties. These usually depend upon the length in wavelengths, the height above ground and the slope.

The various forms of the half-wave horizontal antenna produce maximum radiation at right angles to the wire, but the directional effect is not very great excepting for very low vertical angles of radiation (such as would be effective on 10 meters). Nearby objects also minimize the directivity of a dipole radiator so that it hardly seems worth while to go to the trouble to rotate a simple half-wave dipole in an attempt to improve transmission and reception in any direction.

The half-wave doublet, zepp, single-wired, matched impedance and Johnson Q antenna all have practically the same radiation pattern *when properly built and adjusted*. They are all dipoles, and the feeder system should have no effect on the radiation pattern.

When a multiplicity of radiating dipoles are so located and phased as to reinforce the radiation in certain desired directions and to neutralize radiation in other directions, a directive antenna array is formed.

The function of a directive antenna when used for transmitting is to give an increase in signal strength in some direction at the expense of reduced signal in other directions. For reception, one might find useful an antenna giving little or no gain in the direction from which it is desired to receive signals if the antenna is able to *discriminate against interfering* signals and static arriving from other directions. A good directive transmitting antenna, however, can generally also be used to good advantage for reception. This is covered in detail later in this chapter.

If radiation can be confined to a narrow beam, the signal intensity can be increased a great many times in the desired direction of transmission. This is equivalent to increasing the power output of the transmitter. On the higher frequencies it is more economical to use a directive antenna than to increase transmitter power if more than a few watts power is being used.

Directive antennas can be designed to give as high as 23 db gain over that of a single half-wave antenna. However, this high gain (nearly 200 times as much power) is con-

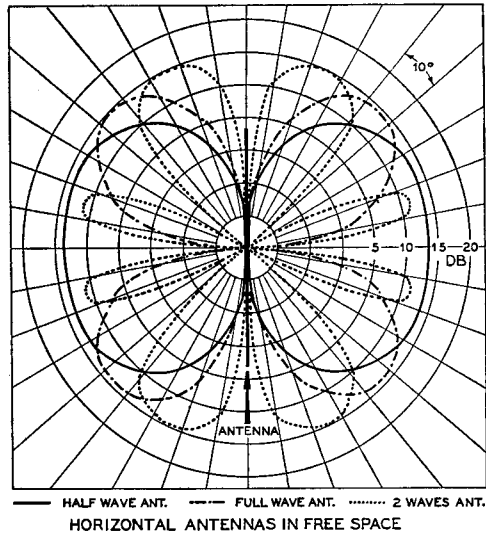

Figure 24.
THEORETICAL FIELD STRENGTH IN DB
UNITS FOR THREE TYPES OF ANTENNAS
IN FREE SPACE.

To obtain a true picture, one must visualize the radiation lobes in space as encircling the antenna and cutting the page on the dotted lines. The presence of the earth distorts the patterns considerably unless the antenna is several wavelengths above ground.

finer to such a narrow beam that it can be used only for commercial applications in point-to-point communication.

The increase in radiated power in the desired direction is obtained with a corresponding loss in all other directions. Gains of 3 to 10 db seem to be of more practical value for amateur communication because the angle covered by the beam is wide enough to sweep a fairly large area. Three to 10 db means the equivalent of increasing power from 2 to 10 times.

Horizontal Pattern vs. Vertical Angle. For each of the amateur high-frequency bands, there is a certain optimum vertical angle of radiation. Energy radiated at an angle much higher than this optimum angle is largely lost, while radiation at angles much lower than this optimum angle oftentimes is not nearly so effective in producing signals at a distant station.

For this reason, the horizontal directivity pattern as measured on the ground is of no import when dealing with frequencies and distances dependent upon sky wave propagation. It is the horizontal directivity (or gain

LONG-ANTENNA DESIGN CHART								
		Length in Feet						
		End-Fed Antennas						
Frequency in Mc.	1λ	1½λ	2λ	2½λ	3λ	3½λ	4λ	4½λ
30	32	48	65	81	97	104	130	146
29	33	50	67	84	101	118	135	152
28	34	52	69	87	104	122	140	157
14.4	66½	100	134	169	203	237	271	305
14.2	67½	102	137	171	206	240	275	310
14.0	68½	103½	139	174	209	244	279	314
7.3	136	206	276	346	416	486	555	625
7.15	136½	207	277	347	417	487	557	627
7.0	137	207½	277½	348	418	488	558	628
4.0	240	362	485	618	730	853	977	1100
3.9	246	372	498	625	750	877	1000	1130
3.8	252	381	511	640	770	900	1030	1160
3.7	259	392	525	658	790	923	1060	1190
3.6	266	403	540	676	812	950	1090	1220
3.5	274	414	555	696	835	977	1120	
2.0	480	725	972	1230	1475			
1.9	504	763	1020	1280				
1.8	532	805	1080					

or discrimination) measured at the most useful vertical angles of radiation that is of consequence. The horizontal radiation pattern as measured on the ground is considerably different from the pattern obtained at a vertical angle of 15 degrees, and still more different from a pattern obtained at a vertical angle of 30 degrees. In general, a propagation angle of anything less than 30° above the horizon has proved to be effective for 40- and 80-meter operation over long distances. The energy which is radiated at angles higher than approximately 30° above the earth is not very effective at these frequencies for dx.

For operation at higher frequencies (lower wavelengths), such as in the vicinity of 20 meters, the most effective angle of radiation is usually about 15° above the horizon, from any kind of antenna. The most effective angles for 10-meter operation are those in the vicinity of 10°. These angles give best results for long-distance communication because the waves are most effectively reflected from the Heaviside layer for the various frequencies or wavelengths mentioned.

The fact that many simple arrays give considerably more gain at 10 and 20 meters than one would expect from consideration of the horizontal directivity can be explained by the fact that, besides providing some horizontal directivity, they concentrate the radiation at a lower vertical angle. The latter may actually account for the greater portion of the gain obtained by some simple 10-meter arrays. The gain that can be credited to the

increased horizontal directivity is never more than 4 or 5 db at most with the simpler arrays. At 40 and 80 meters this effect is not so pronounced, most of the gain from an array at these frequencies resulting from the increased horizontal directivity. Thus, a certain type of array may provide 12 to 15 db effective gain over a dipole at 10 meters, and only 3 or 4 db gain at 40 meters.

There is an endless variety of directive arrays that give a substantial power gain in the favored direction. However, some are more effective than others taking up the same space, some are easier to feed, and so forth. For this reason, only those arrays that are specifically recommended as being highly satisfactory for amateur work are described in this book. To include all the various directive antennas that have been developed in the last decade alone would take more space than can be devoted to the subject here.

Long Wire Radiators

Harmonically operated antennas radiate better in certain directions than others, but cannot be considered as having appreciable directivity unless several half wavelengths long. The current in adjoining half-wave elements flows in opposite directions, and thus the radiation from the various elements, being out of phase, adds in certain directions and neutralizes in others.

A half-wave doublet in free space has a "doughnut" of radiation surrounding it. A

full wave has two; three half waves three; and so on. When the radiator is made more than four half wavelengths long, the *end* lobes (cones of radiation) begin to show noticeable power gain over a half-wave doublet, while the broadside lobes get smaller and smaller in amplitude, even though numerous.

The horizontal radiation pattern of such antennas depends upon the vertical angle of radiation being considered. If the wire is more than four wavelengths long, the maximum radiation at vertical angles of 15 to 20 degrees (useful for dx) is in line with the wire, being slightly greater a few degrees either side of the wire than directly off the ends. The directivity of the main lobes of radiation is not particularly sharp, and the minor lobes fill in between the main lobes to permit working stations in nearly all directions, though the power radiated broadside to the radiator will not be great if the radiator is more than a few half wavelengths long.

To maintain the out-of-phase condition in adjoining half-wave elements throughout the length of the radiator, it is necessary that a harmonic antenna be fed either at *one end* or at a *current* loop. If fed at a voltage loop, the adjacent sections will be fed *in phase*, and a different radiation pattern will result.

The directivity of a long wire does not increase very much as the length is increased beyond about 15 wavelengths. In fact, the directivity does not go up in proportion to the additional cost of the long wire after about 8 wavelengths are used. This is due to the fact that all long-wire antennas are adversely affected by the r.f. resistance of the wire. This resistance also affects the Q or selectivity of the long wire, and as the length is increased, the tuning of the antenna becomes quite broad. In fact, a long wire about 15 waves long is practically aperiodic and works almost equally well over a wide range of frequencies.

One of the most practical methods of feeding a long-wire antenna is to bring one end of it into the radio room for direct connection to a tuned antenna circuit which is link-coupled to the transmitter. The antenna can be tuned to exact resonance for operation on any harmonic by means of the tuned circuit which is connected to the end of the antenna. This tuned circuit corresponds to an adjustable, nonradiating half-wave section of the antenna. A ground is sometimes made to the center of the tuned coil.

If desired the antenna can be opened and current-fed at a point of maximum *current* by means of a twisted-pair feeder, concentric line, or a Q matching system and open line.

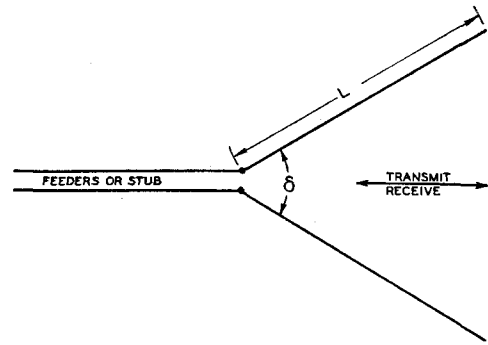

Figure 25.
TYPICAL V-BEAM ANTENNA.

The V Antenna

If two long-wire antennas are built in the form of a V, it is possible to make two of the maximum lobes of one leg shoot in the same direction as two of the maximum lobes of the other leg of the V. The resulting antenna is a bidirectional (two opposite directions) for the main lobes of radiation. Each side of the V can be made any odd or even multiple of quarter wavelengths, depending on the method of feeding the apex of the V. The complete system must be a multiple of half waves. If each leg is an even number of quarter waves long, the antenna must be voltage-fed; if an odd number of quarter waves long current feed must be used.

By choosing the proper angle δ , figure 25, the lobes of radiation from the two long-wire antennas aid each other to form a bidirectional beam. Each wire by itself would have a radiation pattern similar to that shown for antennas operated on harmonics. The reaction of one upon the other removes two of the four main lobes and increases the other two in such a way as to form two lobes of still greater magnitude.

The correct wire lengths and the degree of the angle δ are listed in the *V-Antenna Design Table* for various frequencies in the 10-, 20- and 40-meter amateur bands. These values must sometimes be reduced slightly if one of the wires is in the vicinity of some large object.

The legs of a very long wire V antenna are usually so arranged that the included angle is twice the angle of the major lobe from a single wire if used alone. This arrangement concentrates the radiation of each wire along the bisector of the angle and permits part of the other lobes to cancel each other.

V-ANTENNA DESIGN TABLE

Frequency in Kilocycles	$L = \lambda$ $\delta = 90^\circ$	$L = 2\lambda$ $\delta = 70^\circ$	$L = 4\lambda$ $\delta = 52^\circ$	$L = 8\lambda$ $\delta = 39^\circ$
28000	34' 8"	69' 8"	140'	280'
28500	34' 1"	68' 6"	137' 6"	275'
29000	33' 6"	67' 3"	135'	271'
29500	33'	66' 2"	133'	266'
30000	32' 5"	65'	131'	262'
14050	69'	139'	279'	558'
14150	68' 6"	138'	277'	555'
14250	68' 2"	137'	275'	552'
14350	67' 7"	136'	273'	548'
7020	138' 2"	278'	558'	1120'
7100	136' 8"	275'	552'	1106'
7200	134' 10"	271'	545'	1090'
7280	133' 4"	268'	538'	1078'

With legs shorter than three wavelengths, the best directivity and gain are obtained with a somewhat smaller angle than that determined by the lobes. Optimum directivity for a one-wave V is obtained when the angle is 90° rather than 108° as determined by the ground pattern alone.

If very long wires are used in the V, the angle between the wires is almost unchanged when the length of the wires in wavelengths is altered. However, an error of a few degrees causes a much larger loss in directivity and gain in the case of the longer V than in the shorter one, which is broader.

The V antenna can have each leg either an even or an odd number of quarter waves long. If an even number of quarter waves long, the antenna must be voltage-fed at the apex of

the V, while if an odd number of quarter waves long, current feed can be used.

The vertical angle at which the wave is best transmitted or received from a horizontal V antenna depends largely upon the included angle. The sides of the V antenna should be at least a half wavelength above ground; commercial practice dictates a height of approximately a full wavelength above ground.

The Rhombic Antenna

The terminated *rhombic* or *diamond* is probably the most effective directional antenna that is practical for amateur communication. This antenna is nonresonant, with the result that it can be used on three amateur bands, such as 10, 20 and 40 meters.

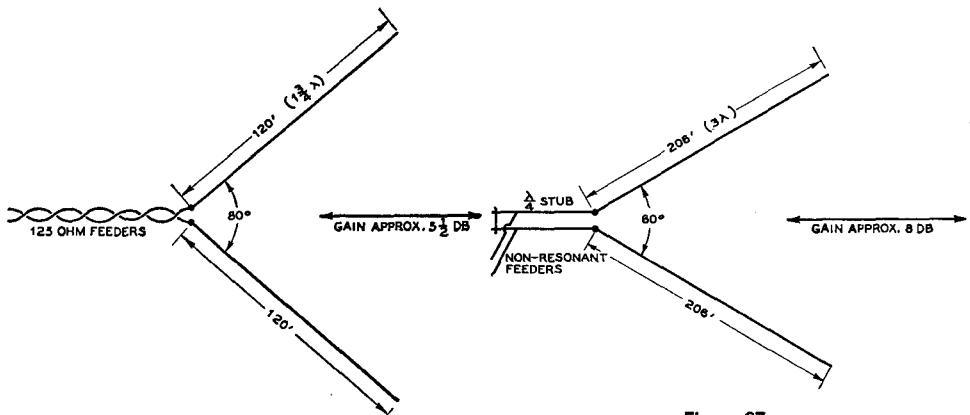
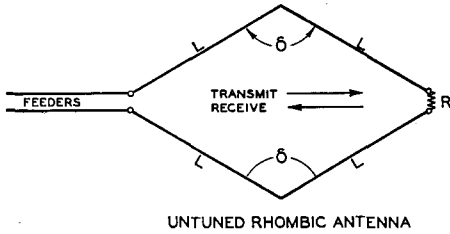

Figure 26.
20-METER V ANTENNA, SMALLEST WORTH-
WHILE SIZE.

Figure 27.
20-METER V WITH MODERATE GAIN AND
DIRECTIVITY, BEST SUITED FOR GENERAL
AMATEUR USE.



UNTUNED RHOMBIC ANTENNA

Figure 28.

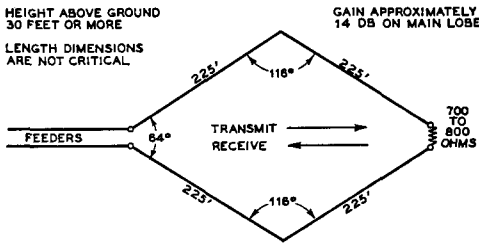

RHOMBIC ANTENNA FOR 7, 14, AND 28 MC. BANDS

Figure 29.

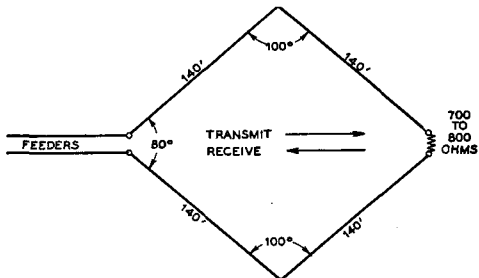

SMALLER RHOMBIC OR DIAMOND ANTENNA SUITABLE FOR 7, 14, AND 28 MC. BANDS

Figure 30.

When the antenna is non-resonant, i.e., properly terminated, the system is unidirectional and the wire dimensions are not critical. The rhombic antenna can be suspended over irregular terrain without greatly affecting its practical operation.

When the free end is terminated with a resistance of a value between 700 and 800 ohms, as shown in figures 28, 29 and 30, the backwave is eliminated, the forward gain is increased and the antenna can be used on several bands without changes. The terminating resistance should be capable of dissipating one-third the power output of the

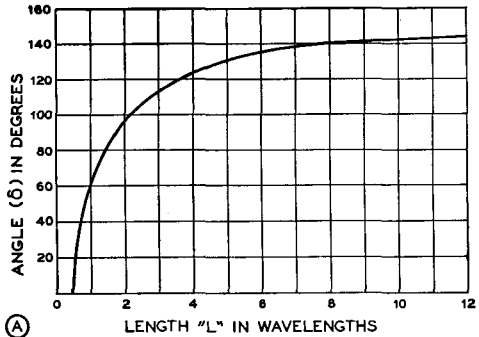

(A)

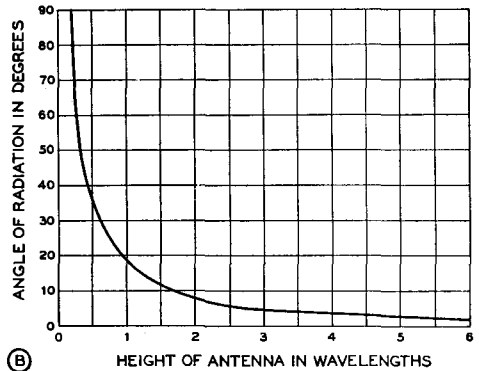

(B)

Figure 31.
DIAMOND ANTENNA DESIGN CHARTS.

transmitter and should have very little reactance. A bank of lamps can be connected in series parallel for this purpose or heavy duty carbon rod resistances can be used. For medium or low power transmitters, the non-inductive *plaque* resistors will serve as a satisfactory termination. Several manufacturers offer special resistors suitable for terminating a rhombic antenna.

The terminating device should, for technical reasons, present a small amount of inductive reactance at the point of termination. However, this should not be too great. By using a bank of lamps in series-parallel, this qualification will be met. The total power dissipated by the lamps will be roughly a third of the transmitter output.

Because of the high temperature coefficient of resistance for both carbon and Mazda lamps, neither type is any too satisfactory when used alone, especially in a keyed transmitter. However, by connecting both types in parallel, the resistance can be made fairly constant. This is because the coefficient of

one type of lamp is positive, while that of the other is negative. The most constant combination will utilize a 110-volt carbon lamp of 2X watts across each 125-volt Mazda lamp of X watts. Thus, a 60-watt Mazda lamp would have a 120-watt carbon lamp across it. The desired resistance can be obtained by series-connecting or series-paralleling several such units.

A compromise terminating device commonly used consists of a terminated 250-foot or longer length of line made of resistance wire which *does not have too much resistance per unit length*. If the latter qualification is not met, the reactance of the line will be excessive. A 250-foot line consisting of no. 25 nichrome wire, spaced 6 inches and terminated with 800 ohms will serve satisfactorily. Because of the attenuation of the line, the lumped resistance at the end of the line need dissipate but a few watts even when high power is used. A half-dozen 5000-ohm 3-watt carbon resistors in parallel will serve for all except very high power. The attenuating line may be either coiled or folded back on itself to take up less room.

The determination of the best value of terminating resistor must be made while *transmitting*, as the input impedance of the average receiver is considerably lower than 800 ohms. This mismatch will *not* impair the *effectiveness* of the array on *reception*, but as a result the value of resistor which gives the best directivity on reception will not give the most gain when transmitting. It is preferable to adjust the resistor for maximum gain when transmitting, even though there will be but little difference between the two conditions.

The input resistance of the diamond which is reflected into the transmission line that feeds it is always somewhat less than the terminating resistance, and is around 700 or 750 ohms when the resistor is 800 ohms.

The antenna should be fed with a nonresonant line, preferably with an impedance of approximately 700 ohms. The four corners of the diamond, when possible, should be at least a half wavelength above ground at the lowest frequency of operation. For three-band operation, the proper angle δ for the center band should be observed.

The diamond antenna transmits a horizontally polarized wave at a low angle above the horizon in the case of a large antenna. The angle of radiation above the horizon goes down as the height above ground is increased.

Unless unavoidable the diamond antenna should not be tilted in any plane. In other words, the poles should be the same height

and the plane of the antenna should be parallel with the ground. Tilting the antenna simply sacrifices about half the directivity due to the fact that the reflection from the ground does not combine with the incident wave in the desired phase unless the antenna is parallel with the ground.

A good deal of directivity is lost when the terminating resistor is left off and it is operated as a resonant antenna. If it is desired to reverse the direction of maximum radiation, it is much better practice to run feeders to both ends of the antenna and mount terminating resistors also at both ends. Then, with either mechanically- or electrically-controlled, remote-controlled double-pole double-throw switches located at each end of the antenna, it becomes possible to reverse the array quickly for transmission or reception to or from the opposite direction.

The directive gain of the rhombic antenna is dependent on the height above ground and the side angle as well as the overall length of each of the four radiating wires in the array. Therefore, the gain is not easy to calculate.

Stacked Dipole Antennas

The characteristics of a half-wave dipole have already been described. When another dipole is placed in the vicinity and excited either directly or parasitically, the resultant radiation pattern will depend upon the spacing and phase differential as well as the relative magnitude of the currents. With spacings less than 0.65 wavelength, the radiation is mainly broadside to the two wires (bidirectional) when there is no phase difference, and *through* the wires (end fire) when the wires are 180 degrees out of phase. With phase differences between 0 and 180 degrees (45, 90 and 135 degrees for instance), the pattern is somewhat unsymmetrical, the radiation being *greater in one direction* than in the opposite direction. In fact, with certain critical spacings the radiation will be practically unidirectional for phase differences of 45, 90 and 135 degrees. However, phase differences of other than 0 and 180 degrees are difficult to obtain except with parasitically excited elements.

With spacings of more than 0.7 wavelength, more than two main lobes appear for all phasing combinations; hence, such spacings are seldom used.

With the dipoles driven so as to be in phase, the most effective spacing is between 0.5 and 0.65 wavelength. The latter provides greater gain, but two minor lobes are present which do not appear at 0.5-wavelength spac-

ing. The radiation is broadside to the plane of the wires and the gain is slightly greater than can be obtained from two dipoles out of phase. The gain falls off rapidly for spacings less than 0.375 wavelength, and there is little point in using spacing of 0.25 wavelength or less with in-phase dipoles except where it is desirable to increase the radiation resistance. (See *Multi-Wire Doublet*.)

When the dipoles are fed 180 degrees out of phase, the directivity is through the plane of the wires and is greatest with close spacing, though there is but little difference in the pattern after the spacing is made less than 0.125 wavelength. The radiation resistance becomes so low for spacings of less than 0.1 wavelength that such spacings are not practicable for antenna arrays except for receiving.

The best *unidirectional* pattern is obtained with 0.1- or 0.125-wavelength spacing and 135-degree phase lag. As it is rather difficult to get other than 0- and 180-degree phasing in driven radiators, parasitic directors and reflectors are usually resorted to for odd values of phasing. These are driven parasitically rather than directly by feeders, and the phasing can be varied by altering the length of the parasitic elements.

In the three foregoing examples, most of the directivity provided is in a plane at a right angle to the two wires, though when out of phase, the directivity is in a line through the wires, and when in phase, the directivity is *broadside* to them. Thus, if the wires are oriented vertically, mostly horizontal directivity will be provided. If the wires are oriented horizontally, most of the directivity obtained will be *vertical* directivity.

To increase the sharpness of the directivity in all planes that include one of the wires, additional identical elements are added *in the line of the wires* and fed so as to be *in phase*. The familiar H array is one array utilizing both types of directivity in the manner prescribed. The two-section Kraus flat-top beam is another.

These two antennas in their various forms are directional in a horizontal plane in addition to being low angle radiators, and are perhaps the most practicable of the *bidirectional* stacked-dipole arrays for amateur use. More phased elements can be used to provide greater directivity in planes including one of the radiating elements. The H then becomes a barrage or Sterba array.

For unidirectional work, the most practicable stacked dipole arrays for amateurs are those using close-spaced directors and reflectors (0.1 to 0.125 wavelength spacing).

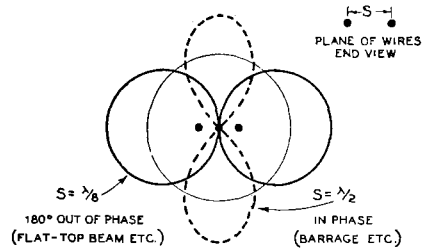

Figure 32.
FIELD STRENGTH PATTERNS OF TWO
DIPOLES WHEN IN PHASE AND WHEN
OUT OF PHASE.

It can be readily seen that if the dipoles are oriented horizontally most of the directivity will be in the vertical plane; if oriented vertically most of the directivity will be horizontal directivity.

While there is almost an infinite variety of combinations when it comes to obtaining directivity by means of stacked dipoles, only those systems which are most practical from an amateur standpoint will be discussed at length.

Colinear Antennas

Franklin or *colinear* antennas are widely used by amateurs. The radiation is bidirectional broadside to the antenna. The antenna consists of two or more half-wave radiating sections with the current *in phase* in each section. This is accomplished by quarter-wave stubs between each radiating section or by means of a tuned coil and condenser or resonant loading coil between each half-wave radiating section.

Two half waves *in phase* will give a gain of slightly more than 2 db with respect to a single half-wave antenna; three sections will give a gain of approximately 4 db. Additional half-wave sections increase this power gain approximately one db per section. The two section colinear antenna is commonly called a *double zepp*.

Various feeder systems are shown in the accompanying sketches. A tuned feeder can be used in place of a quarter-wave stub and 600-ohm line. The latter will allow a two-section *colinear* antenna to be operated as a single section half-wave antenna (current-fed doublet) on the next longer wave amateur band. For example, an antenna of this type would be a half-wave antenna on 40 meters and a two-section *colinear* antenna on 20 meters. The direction of current at a given instant and the location of the current loops are in-

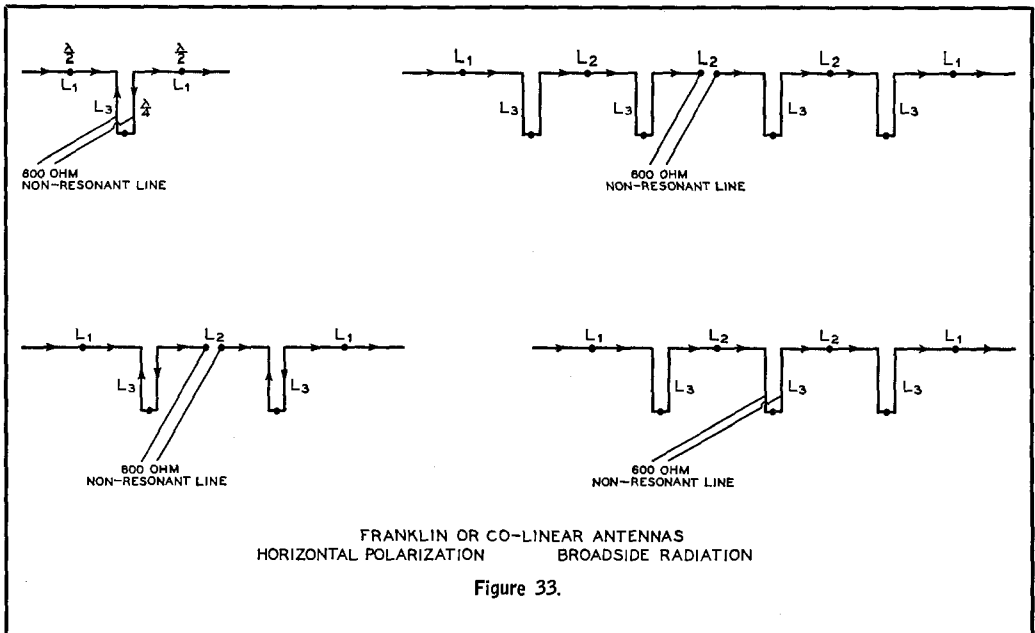

Figure 33.

dicated in the sketches by means of arrow-heads and dots, respectively.

Practically all directivity provided by co-linear sections is in a horizontal plane. The effect on the vertical directivity is negligible when additional sections are provided. For this reason, the Franklin array is useful particularly on the 40-, 80- and 160-meter bands, where low angle radiation is not so important. On the higher frequency bands, 20 and 10 meters, an array providing *vertical directivity in addition to horizontal directivity is desirable*. Hence, the Franklin antenna is not as suited for use on the latter two bands as are some of the arrays to be described.

As additional colinear elements are added to a doublet, the radiation resistance goes up much faster than when additional half waves are added out of phase (harmonic operated antenna).

For a colinear array of from 2 to 6 elements, the radiation resistance in ohms at any current loop is approximately 100 times the number of elements.

It should be borne in mind that the *gain* from a Franklin antenna depends upon the *sharpness* of the horizontal directivity. An array with several colinear elements will give considerable gain but will cover only a very limited arc.

Double Extended Zepp. The gain of a conventional two-element Franklin antenna can be increased to a value approaching that obtained from a three-element Franklin simply by making the two radiating elements 230 degrees long instead of 180 degrees long. The phasing stub is shortened correspondingly to maintain the whole array in resonance. Thus, instead of having 0.5 wavelength elements and a 0.25 wavelength stub, the elements are made 0.64 wavelength long and the stub slightly more than 0.11 wavelength long.

The correct radiator dimensions for a 230 degree double zepp can be obtained from the *Colinear Antenna Design Chart* simply by multiplying the L_1 values by 1.29. The length for L_3 must be determined experimentally for best results. It will be about 1/8 wavelength.

COLINEAR ANTENNA DESIGN CHART

BAND	FRE- QUENCY IN MC.	L_1	L_2	L_3
10 METERS	30	16'	16' 5"	8' 2"
	29	16' 6"	17'	8' 6"
	28	17' 1"	17' 7"	8' 8"
20 METERS	14.4	33' 4"	34' 3"	17' 1"
	14.2	33' 8"	34' 7"	17' 3"
	14.0	34' 1"	35'	17' 6"
40 METERS	7.3	65' 10"	67' 6"	33' 9"
	7.15	67'	68' 8"	34' 4"
	7.0	68' 5"	70' 2"	35' 1"
75 METERS	4.0	120'	123'	61' 6"
	3.9	123'	126'	63'
	80	3.6	133'	136' 5"

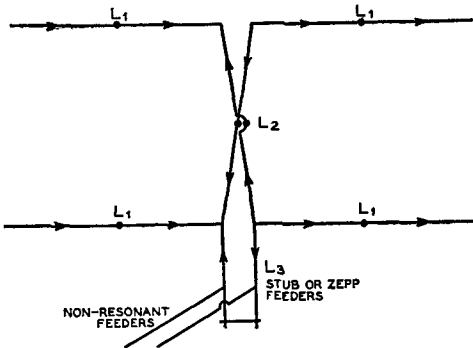

Figure 34.
THE POPULAR "LAZY H"
BI-DIRECTIONAL ARRAY.

Stacking the colinear elements results in both vertical and horizontal directivity.

The *vertical* directivity of a colinear antenna having 230 degree elements is the same as for one having 180 degree elements. However, small parasitic lobes occur in the horizontal pattern with the extended version. The radiation resistance of the extended version is slightly lower.

It will be observed that the overall length of the extended zepp, including phasing section, is longer than the 3/2 wavelength wire that makes up a conventional double zepp. The reason for this is that when a wire is bent anywhere except at a voltage or current loop, the wire must be lengthened to restore resonance.

Multiple-Stacked Broadside Arrays

Colinear elements may be stacked above or below another similar string of elements, thus providing vertical directivity. Two horizontal colinear elements stacked two above the other and separated by a half wavelength form the popular "lazy H" array of figure 34. It is highly recommended for amateur work on 10 and 20 meters when substantial gain without too much directivity is desired. It has high radiation resistance. This results in low voltages and a broad resonance curve, which permits use of inexpensive insulators and enables the array to be used over a fairly wide range in frequency. For dimensions see the stacked dipole design table.

The X-H Array. As previously mentioned under the *double extended zepp*, greater horizontal directivity can be obtained from two horizontal colinear dipoles by extending each to 230 degrees. It also has been

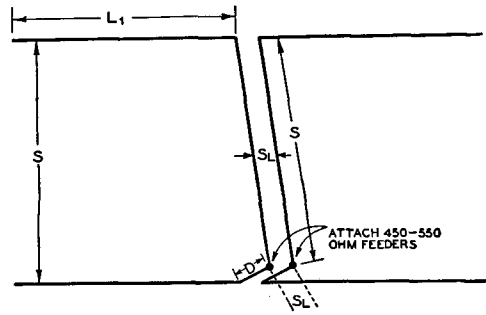

28-29 Mc.	$L_1 = 21\frac{1}{2}'$	$D = 3'$	$S = 24'$
28.5-29.5 Mc.	$L_1 = 21\frac{1}{4}'$	$D = 2\frac{3}{4}'$	$S = 24'$

$S_L = 1\frac{1}{2}''$ OR $2''$ FOR 112 MC.
 $2''$ OR $4''$ FOR 56 MC.
 $4''$ FOR 28 MC.
 $4''$ OR $6''$ FOR 14 MC.

THIS ARRAY MAY BE USED ON HALF (NOT TWICE) FREQUENCY WITH GOOD RESULTS. NO CHANGES ARE REQUIRED.

Figure 35.
THE X-H ARRAY, AN EXPANDED VERSION OF THE "LAZY H."

Dimensions for other amateur bands may be determined by multiplying or dividing the specified lengths for the 28-Mc. band by the corresponding figure.

explained previously that cophased dipoles in a certain arrangement do not show maximum broadside directivity or gain at the common 0.5 wavelength spacing, but at approximately 0.65 wavelength spacing.

Observation of the dimensions of the Smith X-H array in figure 35 will show that the radiating element lengths have been increased to 230 degrees and that the spacing has been increased to almost 0.7 wavelength; otherwise it looks exactly like the familiar Lazy H with two exceptions: the phasing section is *not transposed* and *no matching stub is used*.

Increasing the element lengths and spacing beyond 0.5 wavelength results in parasitic lobes being radiated both in a vertical and a horizontal plane. However, the magnitude of these lobes is small, and effects of their presence can be ignored.

The X-H array can be used with good results on *half* (not twice) frequency with no changes whatsoever, thus permitting two-band operation.

The gain at half frequency will not be as great as when the array is used on its regular frequency, but there is still gain over a regular dipole. The general shape of the pattern is the same on both bands, but it will not be so sharp when the array is used on half frequency.

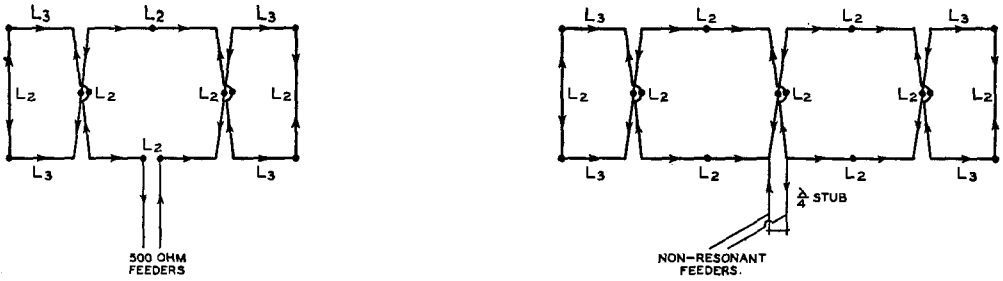

HORIZONTALLY POLARIZED BROADSIDE BARRAGE ANTENNAS

Figure 36.

With a line of 450 to 550 ohms, the standing wave ratio (current excursions) will be very low on the higher frequency band, and will be about 2/1, when the array is used at half frequency. If a slight amount of reactance appears at the transmitter end of the line at half frequency and is found objectionable, the reactance can be eliminated by lengthening or shortening the line until all reactance is eliminated.

To keep the phasing section from flopping around in the wind, it should be pulled away from the array by means of the feed line. The schematic diagram gives the impression that the phasing section is pulled to one side, because of lack of perspective in such a drawing. In actual practice the stub should be pulled in such a manner that the phasing section is still at right angles to the radiating elements. The feeders need not be pulled tight,

but just enough to keep the phasing section from whipping excessively in the wind.

The Sterba "Barrage". Vertical stacking may be applied to strings of colinear elements longer than two half waves. In such arrays the end quarter wave of each string of radiators is usually bent in to meet a similar bent quarter wave from the opposite end radiator. This provides better balance and better coupling between the upper and lower elements when the array is current-fed. Arrays of this type are shown in figure 36, and are commonly known as Sterba or barrage arrays.

Correct length for the elements and stubs can be determined for any stacked dipole from the *Stacked-Dipole Design Table*.

In these sketches the arrowheads represent the direction of flow of current at a given instant; the dots represent the points of maximum current and lowest impedance. All arrows should point in the same direction in each portion of the radiating sections of an antenna in order to provide a field in phase for broadside radiation. This condition is satisfied by the arrays illustrated in figure 36.

If four or more sections are used in a barrage array, the horizontal directivity will be great enough that the array can be used only over a narrow arc (in two opposite directions). For this reason such an array should be oriented with great care.

STACKED-DIPOLE DESIGN TABLE

BAND	FREQUENCY IN MC.	L ₁	L ₂	L ₃
1.25 METERS	240	24"	24½"	12"
	232	25"	25½"	12½"
	224	26"	26½"	13"
2.5 METERS	120	4"	4' 1"	24"
	116	4' 1½"	4' 3"	25"
	112	4' 3"	4' 5"	26"
5 METERS	60	8'	8' 2"	4' 1"
	58	8' 3"	8' 6"	4' 3"
	56	8' 7"	8' 9"	4' 5"
10 METERS	30	16'	16' 5"	8' 2"
	29	16' 6"	17'	8' 6"
	28	17'	17' 7"	8' 9"
20 METERS	14.4	33' 4"	34' 2"	17'
	14.2	33' 8"	34' 7"	17'
	14.	34' 1"	35'	17' 6"
40 METERS	7.3	65' 10"	67' 6"	33' 9"
	7.0	68' 2"	70'	35'

End-Fire Directivity

By spacing two half-wave dipoles or colinear arrays at a distance of from 0.1 to 0.25 wavelength and driving the two 180 degrees out of phase, directivity is obtained through the two wires at right angles to them. Hence, this type of bidirectional array is called *end*

fire. A better idea of end-fire directivity can be obtained by referring to figure 32.

Remember that *end fire* refers to the radiation with respect to the two wires in the array, rather than with respect to the array as a whole.

The vertical directivity of an end fire bidirectional array which is oriented horizontally can be increased by placing a similar end-fire array a half wave below it and excited in the same phase. Such an array is a combination broadside and end-fire affair. However, most arrays are made either broadside or end fire rather than a combination of both, though the latter are quite satisfactory if designed properly.

Kraus Flat-Top Beam. A very effective bidirectional end-fire array is the Kraus *Flat-Top Beam*. Essentially, this antenna consists of two close-spaced dipoles or colinear arrays. Because of the close spacing, it is possible to obtain the proper phase relationships in multisection flat tops by crossing the wires at the voltage loops rather than by resorting to phasing stubs. This greatly simplifies the array. (See figure 37.) Any number of sections may be used though the one- and two-section arrangements are the most popular. Little extra gain is obtained by using more than four sections, and trouble from phase shift may appear.

A center-fed single-section flat-top beam cut according to the table can be used quite successfully on its second harmonic, the pattern being similar except that it is a little sharper. The single-section array can also be used on its fourth harmonic with some success though there will then be four cloverleaf lobes, much the same as with a full-wave antenna.

If a flat-top beam is to be used on more than one band, it is necessary to use tuned feeders.

The radiation resistance of a flat-top beam is rather low, especially when only one section is used. This means that the voltage will be high at the voltage loops. For this reason, especially good insulators should be used for best results in wet weather.

The exact lengths for the radiating elements are not especially critical because slight deviations from the correct lengths can be compensated for in the stub or tuned feeders. Proper stub adjustment is covered on page 412. Suitable radiator lengths and approximate stub dimensions are given in the accompanying design table.

Figure 37 shows top views of eight types of flat-top beam antennas. The dimensions for using these antennas on different bands are

given in the design table. The 7- and 28-Mc. bands are divided into two parts, but the dimensions for either the low- or high-frequency ends of these bands will be satisfactory for use over the entire band.

In any case, the antennas are tuned to the frequency used by adjusting the shorting wire on the stub or tuning the feeders if no stub is used. The data in the table may be extended to other bands or frequencies by applying the proper factor. Thus, for 56- to 58-Mc. operation, the values for 28 to 29 Mc. are divided by two.

All of the antennas have a bidirectional horizontal pattern on their fundamental frequency. The maximum signal is broadside to the flat top. The single-section type has this pattern on both its fundamental frequency and second harmonic. The other types have four main lobes of radiation on the second and higher harmonics. The nominal gains of the different types over a half-wave comparison antenna are as follows: Single-section, 4 db; 2-section, 6 db; 3-section, 7 db; 4-section, 8 db.

The current directions on the antennas at any given instant are shown by the arrows on the wires in the figure. The voltage maximum points, where the current reverses phase, are indicated by small X's on the wires.

The maximum spacings given make the beams less critical in their adjustment. Up to one-quarter wave spacing may be used on the fundamental for the 1-section types and also the 2-section center-fed, but it is not desirable to use more than 0.15 wave-length spacing for the other types.

Although the center-fed type of flat top is generally to be preferred because of its symmetry, the end-fed type is often convenient or desirable. For example, when a flat-top beam is used vertically, feeding from the lower end is in most cases more convenient.

If a multisection flat-top array is end-fed instead of center-fed and tuned feeders are used, stations off the ends of the array can be worked by tying the feeders together and working the whole affair, feeders and all, as a long-wire harmonic antenna. A single-pole double-throw switch can be used for changing the feeders and directivity.

Unidirectional Arrays

If two dipoles or colinear arrays are not exactly 0 or 180 degrees out of phase, the pattern becomes unsymmetrical. For certain phasing combinations and spacings, a very good unidirectional pattern is obtained. The required odd values of phasing can be

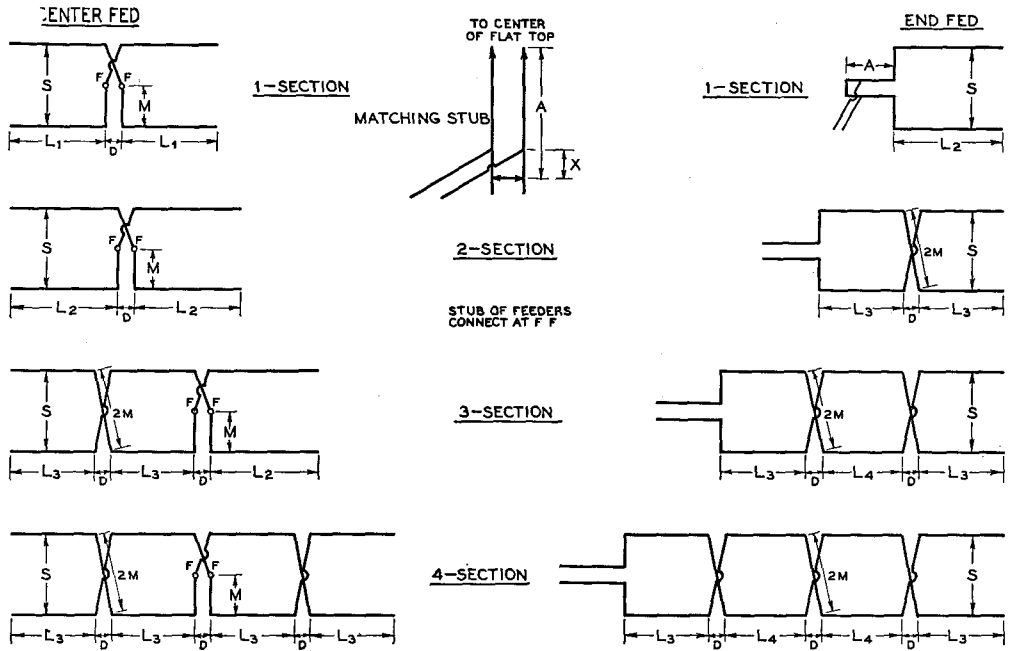

Figure 37.

FLAT-TOP BEAM DESIGN DATA.

FREQUENCY	Spacing	S	L ₁	L ₂	L ₃	L ₄	M	D	A (1/4) approx.	A (1/2) approx.	A (3/4) approx.	X approx.
7.0-7.2 Mc.	$\lambda/8$	17'4"	34'	60'	52'8"	44'	8'10"	4'	26'	60'	96'	4'
7.2-7.3	$\lambda/8$	17'0"	33'6"	59'	51'8"	43'1"	8'8"	4'	26'	59'	94'	4'
14.0-14.4	$\lambda/8$	8'8"	17'	30'	26'4"	22'	4'5"	2'	13'	30'	48'	2'
14.0-14.4	.15 λ	10'5"	17'	30'	25'3"	20'	5'4"	2'	12'	29'	47'	2'
14.0-14.4	.20 λ	13'11"	17'	30'	22'10"	7'2"	2'	10'	27'	45'	3'
14.0-14.4	$\lambda/4$	17'4"	17'	30'	20'8"	8'10"	2'	8'	25'	43'	4'
28.0-29.0	.15 λ	5'2"	8'6"	15'	12'7"	10'	2'8"	1'6"	7'	15'	24'	1'
28.0-29.0	$\lambda/4$	8'8"	8'6"	15'	10'4"	4'5"	1'6"	5'	13'	22'	2'
29.0-30.0	.15 λ	5'0"	8'3"	14'6"	12'2"	9'8"	2'7"	1'6"	7'	15'	23'	1'
29.0-30.0	$\lambda/4$	8'4"	8'3"	14'6"	10'0"	4'4"	1'6"	5'	13'	21'	2'

Dimension chart for flat-top beam antennas. The meanings of the symbols are as follows:

L₁, L₂, L₃ and L₄, the lengths of the sides of the flat-top sections as shown in figure 37. L₁ is length of the sides of single-section center-fed, L₂ single-section end-fed and 2-section center-fed, L₃ 4-section center-fed and end-sections of 4-section end-fed, and L₄ middle sections of 4-section end-fed.

S, the spacing between the flat-top wires.

M, the wire length from the outside to the center of each cross-over.

D, the spacing lengthwise between sections.

A (1/4), the approximate length for a quarter-wave stub.

A (1/2), the approximate length for a half-wave stub.

A (3/4), the approximate length for a three-quarter wave stub.

X, the approximate distance above the shorting wire of the stub for the connection of a 600-ohm line. This distance, as given in the table, is approximately correct only for 2-section flat-tops.

For single-section types it will be smaller and for 3- and 4-section types will be larger.

The lengths given for a half-wave stub are applicable only to single-section center-fed flat-tops. To be certain of sufficient stub length, it is advisable to make the stub a foot or so longer than shown in the table, especially with the end-fed types. The lengths, A, are measured from the point where the stub connects to the flat-top.

Both the center and end-fed types may be used horizontally. However, where a vertical antenna is desired, the flat-tops can be turned on end. In this case, the end-fed types may be more convenient, feeding from the lower end.

obtained by cutting a parasitically driven element so as to present just the right amount of reactance. Whether the parasitic element acts as a director or reflector depends upon whether the reactance is inductive or capacitive. A parasitic reflector is made just a little longer than an electrical half wavelength, and a director a little shorter than an electrical half wave.

The presence of one or more parasitic elements affects the driven element itself, introducing some reactance so that slight compensation in the physical length is necessary for resonance. The presence of parasitic elements also reduces the radiation resistance; the more elements, the lower the radiation resistance. Reducing the spacing between the driven dipole and parasitic elements further reduces the radiation resistance. Spacings of 0.1 to 0.125 wavelength are highly satisfactory for either a director or reflector.

The phasing adjustment (length of parasitic elements) is quite critical with respect to frequency, and can best be accomplished by cut-and-try and the help of a field strength meter. This is especially true when more than one parasitic element is utilized. It will be found that the adjustment which gives the best forward gain is not the same as that which gives best front to back discrimination, though they are approximately the same.

If only one parasitic element is used, the nose of the directivity pattern will be quite broad though the front-to-back radiation ratio will be quite high. The pattern resembles a valentine heart except that the tip is rounded instead of pointed. If the phasing is adjusted for maximum forward gain rather than maximum discrimination, a small lobe in the backward direction will appear and the nose of the main lobe will be slightly sharper.

The foregoing applies to the horizontal directivity when the driven and parasitic dipoles are *vertical*. When the dipoles are orientated *horizontally*, as in most amateur applications for wavelengths above 5 meters, the pattern is somewhat different, the horizontal directivity *depending upon the vertical angle of radiation*. The horizontal directivity is greatest for low vertical angles of radiation when the dipoles are oriented horizontally. For this reason, such an array will exhibit greater discrimination on 10 meters than on 40 meters, for instance.

A close-spaced parasitic director or reflector will lower the radiation resistance of the driven element. If two parasitic elements are used, the radiation resistance will be lowered still more. Consequently, the

voltage at the ends of the dipoles of such an array is high and good insulation is essential, not only because of loss but because the phasing will be affected by wet weather if poor insulators are used at the high voltage points. Self-supporting quarter-wave rods permit construction of 10- and 20-meter arrays of this type without the need for insulators at high voltage points.

The low radiation resistance makes the problem of current (center) feed quite difficult. Twisted pair or concentric line cannot be used without incorporating a matching transformer. A linear transformer of tubing (Q section) cannot be practically designed to have a low enough surge impedance to match a 600-ohm line. A *simple* feed method that is satisfactory is a delta-matched open-wire line of from 400 to 600 ohms. The feeder should be fanned out and attached a short distance each side of the center of the driven dipole. The feeders should be slid back and forth equidistant from the center until standing waves on the line are at a minimum.

A horizontal driven dipole and close-spaced director or director and reflector are commonly used as a rotatable array on 10 and 20 meters; such an arrangement is discussed at length later in this chapter.

Orientation of Beam Antennas

Directive antennas, especially those sharp enough to give a large effective power gain, should be so oriented that the line or lines of maximum radiation fall in the desired direction or directions.

To do this, the direction of *true north* must be known with reasonable accuracy. This may vary in the United States by as much as 20 degrees from magnetic north as indicated by a compass.

The magnetic declination (variation of magnetic north in degrees east or west of true north) for your locality can be obtained by referring to a map compiled by the U. S. Coast and Geodetic Survey and available from the Superintendent of Documents, Washington, D. C. The number of the map is 3077 and it is sent only on receipt of 20 cents in *coin*.

A simpler method of determining your declination is to inquire of your city engineers or any surveyor or civil engineer in your locality. Any amateur astronomer can also help you to determine the direction of true north.

If a beam antenna is to be aimed at a locality more than 2000 miles distant and the array has a sharp pattern, it will be neces-

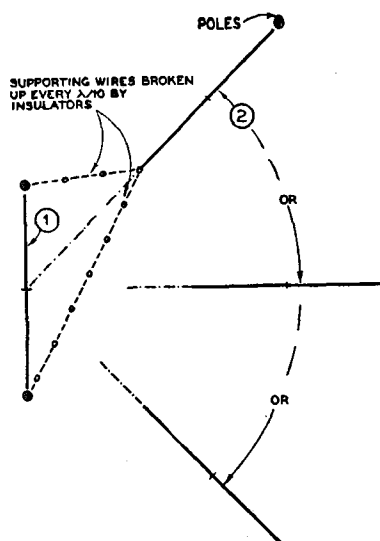

Figure 38.

Illustrating how two dipoles or arrays with horizontal elements can be supported from three poles with a minimum of coupling between the two systems. This is an important consideration if maximum directivity is desired.

sary to use *great circle* directions. A simple method is to stretch a thread from the corresponding two points on a large globe (not a cheap one—they are often inaccurate).

Great circle maps also can be used to determine great circle directions if such a map is available centered on a point reasonably close to your locality.

Coupling Between Antennas. If two dipoles or bidirectional arrays are used to cover four directions, one will excite the other as a result of electrostatic and electromagnetic coupling *unless* they are well separated or care is taken in their orientation. This mutual coupling will result in decreased directivity and a slight loss in gain.

To minimize coupling between two horizontally polarized arrays resonant on the same band, they should be oriented so that a line extended through one of them can be made to intersect the center of the other array. This is illustrated in figure 38. To eliminate the necessity for four poles, antenna no. 2 is supported at one end by means of a "V" branching out to both of the other two poles. These two wires should be broken up thoroughly with insulators every few feet as they are right in the field of array or antenna no. 1.

ROTATABLE ARRAYS

The amateur confined to an apartment top or a small city lot is at a marked disadvantage when it comes to erecting antennas that will lay down a strong signal at distant points. Even at 10 and 20 meters it is difficult to string up arrays for various points of the compass without more ground space than is available to the average city amateur. And if the arrays are not placed just right or separated sufficiently, there will be coupling from one array to another, resulting in poor discrimination and directivity. As a result, the city amateur oftentimes turns to a rotatable affair, one which takes up but little ground space and can be aimed in the desired direction.

Unidirectional Rotary Arrays

An effective unidirectional array which is small enough to be rotated without too much difficulty consists of a horizontal dipole and close-spaced parasitic reflector and director.

The use of two parasitic elements instead of one adds little to the mechanical difficulties of rotation, and the gain and discrimination (especially the latter) are considerably improved over that obtained with a single director or a single reflector instead of a combination of both. The three-element array using a close-spaced director, driven element, and close-spaced reflector will exhibit as much as 30 db front-to-back ratio and 20 db front-to-side ratio for *low angle radiation*. The theoretical gain is approximately 8 db over a dipole in free space. In actual practice the array will usually show 10 db or more gain over a horizontal dipole placed the same height above ground (at 28 and 14 Mc.).

There is little to be gained by using more than three elements (one driven and two parasitic). The gain and discrimination are improved very little, and the radiation resistance becomes somewhat low for good efficiency.

There is little to choose as regards the exact spacing of the parasitic elements. Any spacing from 0.1 to 0.15 wavelength may be used for either the director or reflector. However, changes in the spacing will call for slightly different parasitic element lengths.

While the elements may consist of wire supported on a wood framework, self-supporting elements of tubing are to be preferred. The latter type array is easier to construct, looks better, is no more expensive, and avoids the problem of getting sufficiently good insulation at the ends of the elements. The voltages

reach such high values towards the ends of the elements that losses will be excessive unless the insulation is excellent.

The elements may be fabricated of thin-walled steel conduit, hard drawn thin-walled copper tubing, or duralumin tubing. Or, if you prefer, you may purchase tapered copper plated steel tubing elements designed especially for the purpose at only slightly greater expense. In fact, several kits are available complete with rotating mechanism and direction indicator for those who desire to purchase the whole "works" ready to put up.

The radiation resistance of a close-spaced three-element array is quite low, in the vicinity of 10 ohms. Likewise the Q is high, which means that the array is selective as to frequency. This is perhaps the only important disadvantage of the array; it works much better on the exact frequency for which it was cut, the gain and discrimination falling off considerably a few per cent either side of resonance.

Because of the high Q and close spacing, it is desirable to use tubing of sufficient diameter that it doesn't whip about appreciably in the wind, as any change in spacing will produce considerable detuning effect.

The self-supporting elements are usually supported on husky standoff insulators mounted on a wooden cross arm of the type illustrated in figure 39. The voltage at these points is relatively low, but large insulators are used for reasons of mechanical strength. The length of each parasitic element is usually made adjustable by means of at least one sliding telescopic joint on either side of center.

The optimum length for the parasitic elements for a given frequency is quite critical, and difficult to predict for a given installation. It will depend upon the type (diameter) and spacing of the elements, primarily, and is best determined by cut and try. For a starter, the reflector may be made exactly $1/2$ wavelength, the driven element 0.96 of a half wavelength, and the director 0.92 of a half wavelength. A half wavelength for a given frequency may be determined by dividing the frequency into 492, the answer being in feet if the frequency is in megacycles.

Set the array temporarily as high above the ground as can be reached conveniently from a ladder or fence. Then, with a local amateur to give you a check (his receiver must have an "R" meter), adjust the parasitic elements for the best gain. After this point has been found, shorten the director 1% and lengthen the reflector 1%. This improves the discrimination slightly without reducing the gain

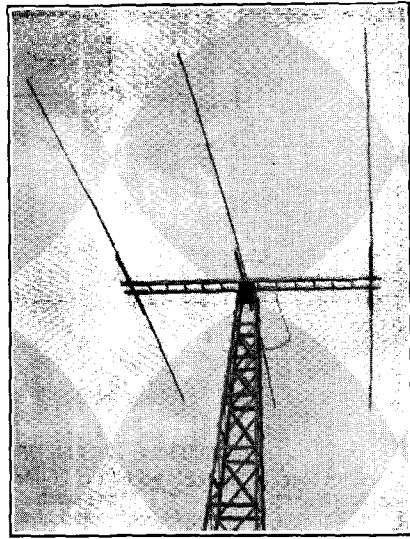

Figure 39.

TYPICAL INSTALLATION OF 3-ELEMENT
CLOSE-SPACED ARRAY.

appreciably, and makes the array tune more broadly.

Feed Methods. The problem of feeding a three-element unidirectional array is complicated not only by the problem of rotation, but also by the low radiation resistance. Special low impedance, flexible coaxial cable with built-in quarter-wave matching section for impedances of this order (10-14 ohms) is available for the purpose, and can be used where the line length is not unduly long. Such cable is simply attached to the center of the driven element, which is split for this type of feed in the same manner as a doublet antenna.

For long line lengths, an open wire line is advisable in the interest of low losses. This type line may be delta matched to the driven element the same as for a delta matched doublet, except that the points of attachment to the driven element will not be the same as for a simple dipole. The feeder wires are simply fanned out until standing waves are at a minimum. This type of feed does not permit quite as good discrimination, as there is a slight amount of radiation from the fanned out portion of the line, and the director and reflector have little effect on this radiation.

Flexible coaxial line may be allowed to dangle against the supporting tower or guy wires or most anything without harm, but an open line must be kept from touching anything or twisting on itself and shorting out. This

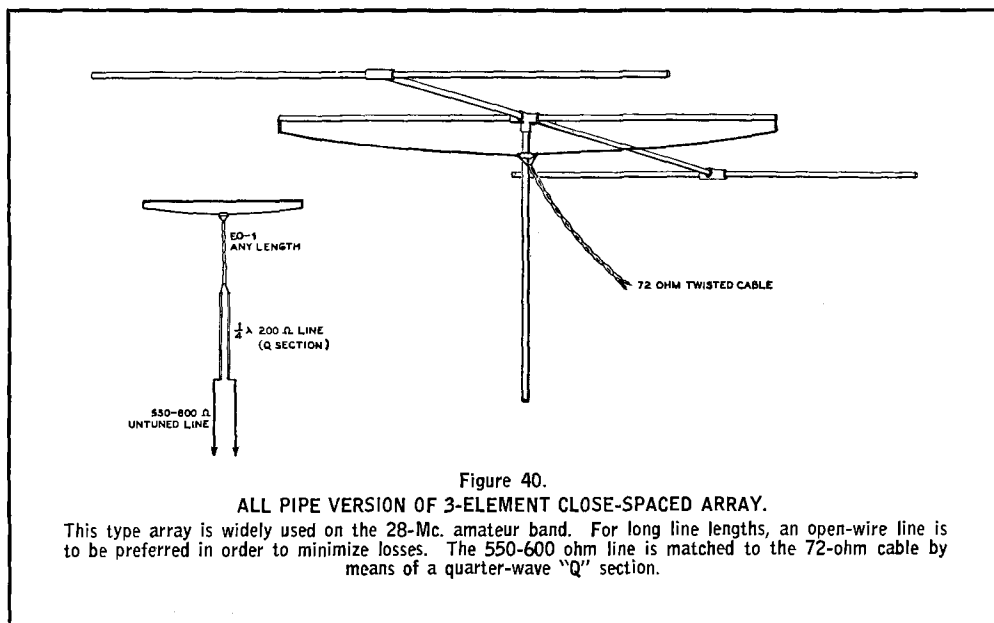

Figure 40.

ALL PIPE VERSION OF 3-ELEMENT CLOSE-SPACED ARRAY.

This type array is widely used on the 28-Mc. amateur band. For long line lengths, an open-wire line is to be preferred in order to minimize losses. The 550-600 ohm line is matched to the 72-ohm cable by means of a quarter-wave "Q" section.

problem is often solved by the incorporation of slip rings and brushes. Not only does this avoid whipping feeders, but permits continuous rotation. Neither voltage nor current is high for a given power at an impedance of 400 to 600 ohms, and there will be little loss in slip rings working at this impedance if they are carefully constructed.

For 28 Mc. or 56 Mc. operation, the array may be made entirely of pipe such as thin-walled electrical conduit. With this type of construction, a method of feed is required which does not necessitate "splitting" the driven element in the center. Such an arrangement is illustrated in figure 40. If the feed line must be longer than about 2 wavelengths, the losses will become appreciable at these frequencies with EO-1 cable, and the arrangement shown in the insert, using a Q section and open wire line, is to be preferred.

The method of feed shown in the illustration permits full 360 degree rotation, yet no precautions need be taken with the feed line as the EO-1 cable can not only touch but even can be wrapped around the supporting pipe without detrimental effects.

With this type feed, the driven element must be slightly longer than for a conventional 3-element array, or about the same length as the reflector. To hold the wire away from the pipe and keep it from slapping the ends of the pipe in a heavy wind, two projections are bolted or soldered or brazed to the ends of the pipe to extend downward about 1 or 1½ inches. A piece of No. 12 wire is stretched

between these as shown in the illustration, the wire being split in the center with an insulator.

W8JK Rotary Array

The Kraus "Flat-Top Beam" is often used as a rotary antenna because of its ability to work on two bands when tuned feeders are used. A single-section 14-Mc. flat-top beam can be used as a two-section 28-Mc. array of the same type. Because the antenna must be fed current on the low-frequency band and voltage on the high-frequency band, an untuned line is not practicable. Therefore a tuned line consisting of no. 12 or no. 14 wire spaced 6 inches is advised for two-band operation.

When a tuned line is used, there will be high voltage at the voltage loops, because of the termination mismatch. The line should be designed with this in mind.

The problem of the open line whipping about is simplified by the fact that the array is bidirectional, thus requiring only 180 degree rotation instead of 360 degree rotation.

17-foot self-supporting rods are a standard size and therefore a two-band flat-top beam for 10 and 20 meters is usually made with 34-foot elements, four 17-foot rods being utilized. The spacing is not critical, 7 or 8 feet being common.

Further details are covered earlier in this chapter under *Flat-Top Beam*. The same considerations apply for a rotatable array as for a stationary one.

Rotating Mechanisms

There are many solutions to the mechanical problem of rotating an array of either of the two types described. The most common system consists of a tower or else a pole of the "telephone" variety atop which is an assembly consisting of bearings and driveshaft assembly, the latter supporting a superstructure of wood, which in turn supports the radiating elements.

A simple rotating and drive mechanism for a 10-meter array can be made from a grinding head or saw mandrel mounted vertically atop the pole or tower. A 20-meter array will require something stronger, an automobile rear axle and housing from a junk dealer serving nicely after being operated on a bit if the tower or pole will support the weight. The "rear end" of a small car such as an Austin is to be preferred to heavier ones.

If a custom made assembly is desired, suitable gears and bearings and pulleys may be obtained from the *Boston Gear Works* at reasonable prices.

Another system that has found favor calls for the whole tower's being mounted on a thrust bearing, the entire mast turning inside a large, guyed bearing near the top of the mast.

The cheapest method of rotating the array from the operating position is by means of ropes and pulleys, but motor drive is highly desirable if one can afford such an installation. Sometimes the motor is placed atop the pole; sometimes it is placed part way down or at the bottom.

The drive motor must be geared down so that the array turns at a speed of from 1 to 2 r.p.m. The motor and gear reduction assembly from a large oscillating fan can be used to rotate most any array, as the torque developed by a small motor is quite high with a gear ratio giving a speed of 1 r.p.m. The oscillating gear shaft on most oscillating fans turns at about 6 r.p.m. and this can easily be stepped down to 1 or 2 r.p.m. by means of a large and a small pulley or a bicycle sprocket and chain.

Two Selsyn type motors make the nicest control system, but any small reversible motor is almost as satisfactory. If the feed line to the array is not designed for continuous rotation, an automatic stop should be provided to prevent damage to the feeders.

If pulleys and belt drive are used, the tension of the belt can be adjusted so that it slips on the pulley when the array hits the "stop", thus preventing damage to both feeders and motor.

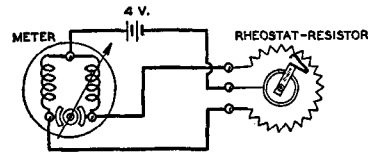

Figure 41.
GASOLINE GAUGE DIRECTION INDICATOR.

The type gasoline gauge required can be purchased reasonably at most any junk yard. It gives an accurate indication of the direction in which the array is pointed after once calibrated.

Direction Indicator

Some means must be provided whereby the operator can tell from the operating position the direction in which the array is "aimed." A simple but highly effective indicating device requiring only three wires between array and operator can be constructed as follows:

From an automobile junk yard, procure a panel type gasoline gauge from a car of '26 to '28 vintage, complete with the potentiometer that goes in the gas tank. Be sure to get the type having three contacts on it. It is preferable that both meter and resistor be from the same make car. The La Salle ('27 and '28 model) is one of the several makes of this era having this type gas gauge.

The three-contact meter is a balanced coil affair, and gives a highly accurate indication that is not affected appreciably by battery deterioration.

File open the case to the resistor unit from the tank and take out the brush and resistor-rheostat affair. Bend the resistor into a complete circle and shorten the brush arm to turn inside it. The resistors are originally built to turn 270 degrees and usually are in the vicinity of 150 ohms.

Attach the reassembled unit to your mast in any way you see fit. Adjust the brush so that it contacts the resistor in the direction from center that your antenna points. Then calibrate your meter to match these cut and tried points. To calibrate, just remove the meter face and turn it over. Paint on any calibration you want.

The meter will work best on 3 to 4½ volts. An ordinary "C" battery will serve nicely, as the current drain is only 20 or 30 ma.

In case the meter doesn't allow enough scale to satisfy you, mount the works in an old alarm clock case—or something similar—and paint the glass black except through where the scale will be read. Glue onto the original

needle a small broom straw, previously dipped in ink, and you can have as much scale as you like. Be sure to allow a little overlap of the straw at the bottom of the needle for counter-balance, as this type meter has no counter-balance spring.

COMPACT ANTENNAS

Often times on the lower frequency bands it is necessary because of space restrictions to use a compromise antenna, an antenna that has been folded or otherwise physically shortened to take up less room than required for a conventional antenna of that frequency. Naturally a constricted antenna will not have as high efficiency, but by going about the problem scientifically it is possible to reduce the size of an antenna with very little sacrifice in efficiency.

Often times it is possible to get the necessary height for a horizontal antenna on 40, 80, or 160 meters, but not the necessary linear span. As the major portion of the radiation from a dipole is from the center half of the dipole, the ends may be bent downward with little effect upon the efficiency and radiation pattern. As much as $\frac{1}{8}$ wavelength at each end of a half-wave dipole may be bent or allowed to hang down if it is necessary in order to get the antenna to fit the span between poles. For the sake of electrical symmetry, it is desirable that the radiator be bent the same amount at each end.

As an example, suppose we would like to string a 130-foot dipole (for 80-meter operation) between two 50-foot poles 90 feet apart. We have 40 feet too much wire; so we shall bend down 20 feet at each end of the dipole. Each bent portion (20 feet) is less than the height of the poles; so there will be no difficulty on that score. The total bent portion (40 feet) is less than half the total length of the radiators; so the efficiency will still be high.

It will be found when bending a radiator at any point other than a voltage or current loop, the length of the radiator must be increased slightly to restore resonance. Therefore when bending a half wave dipole to make it more compact, the length should be increased as necessary to effect resonance.

Multi-Wire Doublets on Half-Frequency. If we bend down the ends of a half-wave dipole until the bent portion at each end is an eighth wavelength long, leaving the flat top a quarter wavelength long, we have an antenna of the type just discussed. If we carry the bending process further and bend the ends not only downwards but back in towards the

center, we have something that resembles a multi-wire doublet designed for the next higher frequency band. Thus we see that a multi-wire half-wave doublet antenna can be used as a *folded* antenna on *half* frequency. The feed line is no longer an untuned feeder, but rather a zepp feed system feeding both ends of the antenna at once. This is possible because the two ends of a dipole are of opposite polarity and phase.

A folded antenna of this type, instead of having very high radiation resistance like a multi-wire doublet system, will have rather low radiation resistance. However it is still sufficiently high to give good radiation efficiency. The folding of the antenna does not cancel the radiation because the current is so much greater in the main portion of the antenna than in the ends which are bent in toward the center, and also because the currents in the parallel wires are less than 180 degrees out of phase.

Loading Coils. An old and still popular method of increasing the electrical length of a wire is by means of a *loading coil*. The customary procedure is to place a loading coil at the current loop (center of a dipole or ground lead of a Marconi) and vary the inductance by means of taps until the desired lengthening effect is obtained.

However, the most desirable place for a loading coil is *not* at the *current loop* but towards the end (voltage loop) of the radiator. If the coil were placed at the extreme end of the antenna, it would have little loading effect, as there would be no current flowing through it. So the coil is placed about $\frac{1}{20}$ wavelength from the end (or ends in the case of a dipole) instead of at the current loop. Thus we see that while a Marconi will still require only one loading coil, a dipole will require two for end loading.

As an example of the desirability of end loading, let's look at a vertical Marconi as used in broadcast work. It has been found that an eighth wavelength vertical radiator loaded to an electrical quarter wavelength by means of a loading coil at the bottom or current loop has a radiation resistance of only 4 or 5 ohms instead of the usual 36 ohms attributed to a $\frac{1}{4}$ -wave vertical Marconi.

If we move the loading coil up nearly to the top of the radiator and add more turns to the coil to compensate for the decreased current flowing through the coil, we find that the antenna now has a radiation resistance of around 20 ohms. Although the height of the radiator is the same, merely by moving the position of the loading coil we have increased the radiation resistance about five times.

The exact position of the coil is not critical; approximately 1/20th wavelength from the far end of a Marconi is a good place for the coil. As previously mentioned, the coil must have considerably more turns to effect resonance than if it were placed at the current loop.

As it is difficult to make adjustments to the coil when it is placed towards the far end of the antenna, the loading coil for an end loaded Marconi is usually wound with somewhat more than the required turns and resonance found by means of a series condenser in the ground lead. This eliminates the necessity for taking the coil down several times to get precisely the right amount of inductance for resonance at the operating frequency. The series condenser also allows one to adjust the antenna for maximum efficiency over the entire band.

The loading coil will be exposed to the weather and hence this should be taken into consideration. No. 14 outside house wire scramble wound on a 1-foot diameter and held in place with tire tape will serve nicely. The exact amount of wire required is difficult to calculate, but it will usually be somewhat more than the amount the radiator (including ground lead) lacks being a quarter wavelength.

RECEIVING ANTENNAS

A receiving antenna should feed as much signal and as little noise—both man-made and atmospheric—to the receiver as possible. Placing the antenna as high as possible and away from house wiring, etc. will provide *physical* discrimination if a transmission line is used which has no signal pickup. Using a *resonant* antenna will provide *frequency* discrimination, attenuating signals and noise on frequencies removed from the resonant frequency of the antenna. Using a *directional* antenna will provide *directional* discrimination, attenuating signals and noise reaching the antenna from directions removed from that of the station transmitting the desired signal.

The ideal antenna has these three kinds of discrimination: physical, frequency and directional, which will thus deliver the most signal and the least amount of noise to the input circuit of the receiver. Such an antenna connected to a mediocre receiver will give better results than will the best receiver made working on a mediocre antenna.

All of the transmitting antennas previously described are suitable for receiving. A good transmitting antenna meets all three

of the desirable requirements set forth above. For this reason, an amateur is seldom justified in erecting a separate antenna system for the purpose of receiving. A d.p.d.t. relay designed for r.f. use, working off the send-receive switch or the communications switch on the receiver, can be used to throw whatever transmitting antenna is being used at the time to the receiver input terminals.

Fortunately, the antenna that delivers the best signal into a certain locality will also be best for receiving from that locality, and conversely the antenna which provides the best received signal will be best for transmitting to the same locality. In fact, a rotary antenna can be aimed at a station for maximum gain when transmitting by the simple expedient of rotating the array for maximum received signal.

As most man-made noise is essentially vertically polarized, an antenna or array with horizontal polarization will give minimum noise pickup from that source. For this reason, an array with horizontal polarization is advisable when it is to be used not only for transmission but also for reception.

The problem of noise pickup is most important because it is the signal-to-noise ratio that limits the signals capable of being received satisfactorily. No amount of receiver amplification will make a signal readable if the noise reaching the receiver is as loud as the signal. Peak-limiting devices will improve reception when trouble is experienced from *short-pulse* popping noises such as auto ignition interference. But no electrical device in the receiver is of avail against the steady buzzing, frying noises present in most urban districts.

For the latter type of interference, caused by power leaks, defective neon signs, etc., a recently developed modification of an old principle is oftentimes of considerable help. A noise antenna, a short piece of wire placed so as to pick up as much of the interfering noise and as little of the desired signal as possible, is fed to the input of the receiver *out of phase* with the energy received from the main antenna. By proper adjustment of coupling and experimentation with the length and placement of the noise antenna, it is sometimes possible to eliminate the offending noise completely. The system of noise bucking is described on page 86 and in greater detail in the RADIO NOISE REDUCTION HANDBOOK.

Stray Pickup. More care has to be taken in coupling a transmission line to a receiver than to a transmitter. The whole antenna

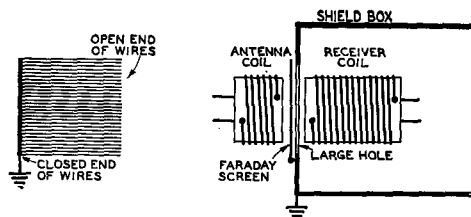

Figure 42.

FARADAY ELECTROSTATIC SHIELD.

system, antenna and transmission line, may tend to act as a Marconi antenna to ground by virtue of capacity coupling. When transmitting, this effect merely lowers the maximum discrimination of a directive array with but little effect on the power gain; with a nondirectional antenna, nothing will even be noticed when there is a very slight amount of Marconi effect. But if the effect is present when *receiving* there is little point in using an antenna removed as far as possible from noise sources because the transmission line itself will pick up the noise.

Faraday Electrostatic Shield. There are two simple ways of avoiding the Marconi effect. The first method calls for a grounded *Faraday screen* between the antenna coil of the receiver and the input grid circuit. This eliminates all capacity coupling. This type of electrostatic screen can be constructed by winding a large number of turns of very small insulated wire on a piece of cardboard which has first been treated with insulating varnish. The wire is wound on, then another coating of varnish is applied.

After it has dried, *one edge* is trimmed with tin snips or heavy shears and the wires are soldered together along the opposite edge. The screen is placed between the two coils and grounded. If properly made, it has little effect on the inductive coupling as there are no closed loops.

Balancing Coils. The second method calls for a center-tapped antenna coil with the center tap grounded. If the coil is not easily accessible, a small center-tapped coil of from 5 to 30 turns is connected across the antenna input to the receiver and the center tap grounded. While not critical, the best number of turns depends upon the type of transmission line, the frequency and the turns on the antenna coil in the receiver. For this reason, the correct number of turns can best be determined by experiment.

The center tap must be at the *exact* electrical center of the coil. The coil may be

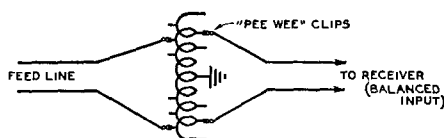

Figure 43.

"AUTOTRANSFORMER" IMPEDANCE MATCHING COIL.

Any two-wire line can be matched to any receiver having balanced input by means of this coupling transformer. The best points at which to tap must be determined by experiment. Both antenna and receiver wires should always be tapped the same number of turns each side of center (ground). A 20- or 25-turn coil wound on a 1-inch form will usually be found optimum. The coil should be tapped every two turns, and at the exact center.

scramble wound and made self-supporting by means of adhesive tape. It should be borne in mind that a twisted-pair or open two-wire line will work *correctly* only if the receiver has provision for balanced (doublet) input. This is especially true of the latter type of line. If one side of the input or antenna coil is grounded inside the receiver, the ground connection must be broken and moved to the center of the coil or an external balancing coil used.

Impedance Matching. Another thing to take into consideration is the impedance of the input circuit of the receiver. If the receiver has high impedance input, it will not give maximum performance when a twisted-pair line is used. If it has low impedance input, it will not give maximum performance with an open-line. Most receivers are designed with 200-to-300 ohm (medium impedance) input and will work well with either type line. However, the performance can sometimes be improved by incorporating an impedance matching transformer even when the receiver has medium impedance (300 ohms) input.

Such a transformer is illustrated in figure 43. If the line is of lower impedance than the receiver input, the line should be tapped across the fewer number of turns to provide the desired impedance step up. If the line is of higher impedance, the converse applies. Often the coupler will work better if a variable condenser is placed across the entire coil to tune it to resonance.

If the line impedance is lower than that of the receiver, the receiver should be tapped across more turns than the line. If the line impedance is higher than that of the receiver input, the converse applies.

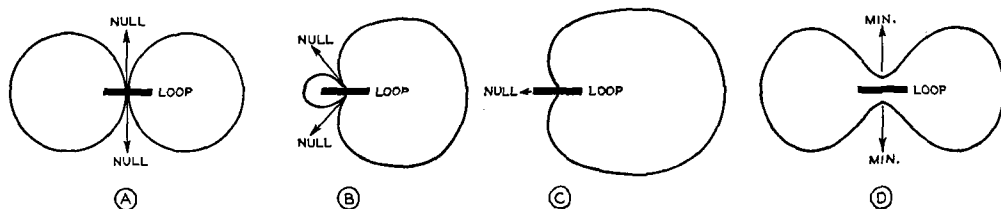

Figure 44.

TYPICAL LOOP ANTENNA PATTERNS.

- A: Loop antenna, either resonant or nonresonant, perfectly balanced to ground (no antenna effect).
 B: Nonresonant loop antenna, moderate antenna effect.
 C: Nonresonant loop antenna, critical amount of antenna effect. Minor lobe completely disappears, leaving only one null.
 D: Resonant loop antenna, moderate antenna effect. Nulls are changed to minima, but remain separated exactly 180 degrees.

Loop Antennas

As a radiation field contains a magnetic component, it is readily apparent that a coil of wire placed in the proper inductive relation to the magnetic component will serve as an antenna. The efficacy as a pickup antenna is low as compared to a regular receiving antenna, but because of its compactness and directional characteristics the loop often is used as a portable antenna or as a direction indicator.

The loop may be in the form of a circle, square, or rectangle whose length and width are not too widely different. It may be wound in the form of a solenoid or in the form of a "pancake" helix. For true loop operation, however, the circumference of the loop should not be more than a small fraction of a wavelength.

The loop may be either resonant or nonresonant, though there will be considerable increase in signal pickup when the loop is resonant to the frequency of the signal being received. Also, the directional pattern is different for the two loops, except when both are perfectly balanced to ground and there is no stray receiver pickup. If there is stray pickup or the loop is not perfectly balanced, an asymmetrical pattern results *except when the loop is tuned to exact resonance*. With a resonant loop, the only effect of circuit unbalance to ground is to result in the absence of complete nulls; instead there will be found *minima* as the loop is rotated, the minima being 180 degrees apart the same as the nulls in a perfectly balanced system.

The result of circuit unbalance to ground or of stray pickup in the input coupling circuit permits the whole loop to work against ground as a Marconi antenna. The current

thus induced combines with the true loop current. If the loop is resonant, the phasing of the two currents is such as to maintain a symmetrical pattern, but there no longer will be complete nulls. If the loop is not resonant, the phasing of the two currents is such as to add in certain directions and cancel completely in others, resulting in an asymmetrical pattern.

Figure 44 shows the patterns obtained under these various conditions. Pattern A is obtained when there is no Marconi effect (also variously known as "antenna effect" or "vertical effect") with either a resonant or nonresonant loop.

With a nonresonant loop, a moderate amount of Marconi effect will produce the pattern shown at B. If the amount of Marconi effect is increased, a point finally will be reached where the small lobe completely disappears, leaving only one null. This pattern is shown at C.

A moderate amount of Marconi effect produces the pattern shown at D when the loop is resonant. When the loop is tuned just slightly off exact resonance, a pattern intermediate between B and D is obtained.

For some applications the entire loop is enclosed in a static shield. For aircraft work this shield greatly reduces "rain static." It also virtually eliminates Marconi effect, which is important in the special circuits used in aircraft direction indicators. These instruments give a continuous indication and have "sense"; that is, they do not have 180 degree ambiguity. However, these instruments are rather complicated, and their theory and operation therefore will not be covered here.

For simple direction finding work, in which two or more bearings are taken and the sta-

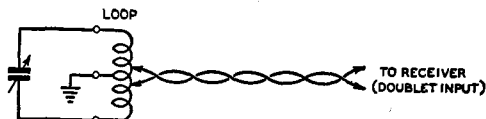

Figure 45.
SIMPLE BUT ACCURATE DIRECTION
FINDER.

If the loop is always tuned to resonance, it is not necessary to provide shielding or balancing adjustments in order to obtain accurate readings. For dimensions and data, refer to text.

tion is located by observing the point of intersection on a map, an unshielded resonant loop will be found satisfactory. The only requirement is that the Marconi effect be not too great; otherwise the minima will not be sharply enough defined for accurate bearings.

Loops can be used to take accurate bearings only when the ground wave strongly predominates. When there is appreciable sky wave signal in addition to the ground wave signal, the loop will give inaccurate bearings as a result of downcoming horizontally polarized waves exciting the horizontal portion of the loop when it is adjusted for a null. This is commonly called "night effect" because for certain frequencies it is serious only at night.

While loop antennas can be used for high frequency reception, they are useless as accurate direction finders when the signal arrives largely or entirely by sky wave propagation, because sky wave signals do not always follow an exact great circle path.

For microwave and ultra high frequency direction finding, compact beam antennas having a sharp null or maximum are preferable to loop antennas, as loop antennas do not work well at these frequencies. U.h.f. direction finding is discussed in the next chapter.

Practical Direction Finding. In figure 45 is shown a simple loop and method of connection to the receiver for use on the 160-meter amateur band or the broadcast band. On these frequencies bearings accurate to less than two degrees can be taken if there is no "night effect," which means 100-200 miles during the day and 50-75 miles at night. The loop also can be used to provide fair pickup (satisfactory on all except very weak signals) up to about 20 Mc. for determining the *approximate* direction of distant stations or the exact direction of local stations.

For frequencies below 2000 kc. the loop may be from 1 to 2 feet square, the larger size providing somewhat greater pickup. For frequencies between 2000 and 10,000 kc. it should be about 1 ft. square, and above 10,000 kc. about 8 or 10 inches square.

The loop is wound with "bell wire" on a wood frame in the form of a "square solenoid" with an exact even number of turns so that the center tap will come at the bottom of the loop. The tuning condenser C may be an ordinary 350- μ fd. broadcast type, fitted with an insulated shaft extension to minimize body capacity.

A twisted pair line is used to couple the loop to the receiver, which should have balanced (doublet) input; that is, neither side of the antenna coupling coil should be grounded in the receiver. The twisted line is tapped symmetrically either side of the grounded center tap on the loop, the feed line taps being adjusted together a turn at a time for maximum signal strength.

To take a bearing, simply tune the loop to resonance as indicated by the signal strength meter on the receiver, the loop direction being adjusted roughly for maximum pickup of the signal. Then check to see if the two minima that are observed as the loop is rotated are exactly 180 degrees apart. If not, the loop is not tuned to exact resonance, and the tuning of C should be altered slightly as necessary to cause the two minima or nulls to fall exactly 180 degrees apart. When this is done, either null may be taken as a bearing.

Surrounding metal objects have a tendency to distort the directional pattern of the loop; likewise large metal objects tend to deflect or reradiate the received signal, resulting in deceptive bearings. To be accurate, loop bearings should be taken with the loop as much in the clear as possible.

Sense Determination. After an accurate bearing is taken with the loop just described, the 180 degree ambiguity can be eliminated as follows.

Tune in a station whose direction is known, and adjust the loop tuning condenser C so that it is considerably on the low capacity side of resonance as indicated by reduced signal pickup. The pattern then will be similar to B of figure 44. If the tuning condenser always is tuned to the same side of resonance and sufficiently off resonance, the small lobe (which is sharper than the large one) will always occur in the direction of the same vertical leg of the loop, which should be given an identifying mark.

Thus, to determine sense, simply detune the condenser C to the low capacity side of resonance and observe the relative positions of the large and small lobes.

Greatest accuracy will be obtained with a loop located high and in the clear, so that the arriving signal is not disturbed by the presence of surrounding objects.

Supporting the Antenna

The foregoing portion of this chapter has been concerned primarily with the *electrical* characteristics and considerations of antennas and arrays. The actual construction of these antennas is just as important. Some of the physical aspects and mechanical problems incident to the actual erection of antennas and arrays will, therefore, be discussed.

Up to 60 feet, there is little point in using mast-type antenna supports unless guy wires must either be eliminated or kept to a minimum. While a little harder to erect because of their floppy nature, fabricated wood poles of the type to be described will be just as satisfactory as more rigid types, *provided* many guy wires are used.

Rather expensive when purchased through the regular channels, 40- and 50-foot telephone poles can *sometimes* be obtained quite reasonably. In the latter case, they are hard to beat inasmuch as they require no guying if set in the ground six feet (standard depth) and the resultant pull in any lateral direction is not in excess of a hundred pounds or so.

For heights of 80 to 100 feet, either three-sided or four-sided lattice type masts are most practicable. They can be made self-supporting, but a few guys will enable one to use a smaller cross section without danger from high winds. The torque exerted on the base of a high self-supporting mast is terrific during a 40- or 50-mile wind.

Guy Wires. Guy wires should never be pulled taut; a *small* amount of slack is desirable. Galvanized wire, somewhat heavier than seems sufficient for the job, should be used. The heavier wire is a little harder to handle, but costs only a little more and takes longer to rust through. Care should be taken to make sure that no kinks exist when the pole or tower is ready for erection as the wire will be greatly weakened at such points if a kink is pulled tight, even if it is later straightened.

If "dead men" are used for the guy wire terminations, the wire or rod reaching from the dead men to the surface should be of non-rusting material such as brass or given a heavy coating of asphalt or other protective substance to prevent destructive action by the damp soil. Galvanized iron wire will last only a short time when buried in moist soil.

Only strain-type (compression) insulators should be used for guy wires. Regular ones might be sufficiently strong for the job, but it is not worth taking chances, and egg-type strain insulators are no more expensive.

Only a brass or bronze pulley should be used for the halyard, as a nice high pole with

a rusted pulley is truly a sad affair. The bearing of the pulley should be given a few drops of heavy machine oil before the pole or tower is raised. The halyard itself should be of good material, preferably waterproofed. Hemp rope of good quality is better than window sash cord from several standpoints and is less expensive. Soaking it thoroughly in engine oil of medium viscosity and then wiping it off with a rag will not only extend its life but minimize shrinkage in wet weather. Because of the difficulty in replacing a broken halyard (procedure described later), it is a good idea to replace them periodically, without waiting for them to show excessive wear or deterioration.

Screw eyes should not be used in connections where appreciable tension will occur. The bite of the threads is not sufficient to withstand much loading. They should be used only to hold guy wires and such *in position*; the wires should always be wrapped around the mast or pole. Nails will serve just as well, and are cheaper.

Trees as Supports. Often a tall tree can be called upon to support one end of an antenna, but one should not attempt to attach anything to the top as the swaying of the top of the tree during a heavy wind will complicate matters.

If a tree is utilized for support, provision should be made for keeping the antenna taut without submitting it to the possibility of being severed during a heavy wind. This can be done by the simple expedient of using a pulley and halyard with weights attached to the lower end of the halyard to keep the antenna taut. Only sufficient weight to avoid excessive sag in the antenna should be tied to the halyard as the continual swaying of the tree submits the pulley and halyard to considerable wear.

Galvanized iron pipe or steel tube conduit is often used as a vertical radiator and is quite satisfactory for the purpose. However, when used for supporting antennas, it should be remembered that the grounded supporting poles will distort the field pattern unless spaced some distance from the radiating portion of the antenna.

Painting. The life of a wood mast or pole can be increased several hundred per cent by protecting it from the elements with a coat or two of paint. And, of course, the appearance is greatly enhanced. The wood should first be given a primer coat of flat white outside house paint, which can be thinned down a bit to advantage with second-grade linseed oil. For the second coat, which should not be applied until the first is thor-

oughly dry, *aluminum paint* is not only the best from a preservative standpoint but looks very well. This type of paint when purchased in quantities is considerably cheaper than might be gathered from the price asked for quarter-pint cans.

Portions of posts or poles below the surface of the soil can be protected from termites and moisture by painting with creosote. While not so strong initially, redwood will deteriorate much more slowly when buried than will the white woods such as pine.

Antenna Wire. The antenna or array itself presents no especial problem. A few considerations should be borne in mind, however. For instance, soft-drawn copper should not be used, as even a short span will stretch several per cent after whipping around in the wind a few weeks, thus affecting the resonant frequency. Enamelled-copper wire as ordinarily available at radio stores is usually soft drawn, but by tying one end to some object such as a telephone pole and the other to the frame of an auto, a few husky tugs can be given and the wire, after stretching a bit, is equivalent to hard drawn.

Where a long span of wire is required, or where heavy insulators in the center of the span result in considerable tension, copper-clad steel wire is somewhat better than hard-drawn copper. It is a bit more expensive though the cost is far from prohibitive. The use of such wire, in conjunction with strain insulators, is advisable where the antenna would endanger persons or property should it break.

For transmission lines, steel core wire will prove awkward to handle, and hard-drawn copper should therefore be used. If the line is long, the strain can be eased by supporting it at several points.

The use of copper tubing for antennas (except at u.h.f.) is not only expensive but unjustifiable. Though it was a fad at one time, there is no excuse for using anything larger than no. 10 copper or copper-clad wire for any power up to one kilowatt. In fact, no. 12 will do the trick just as well and passes the underwriter's rules if copper-clad steel is used. For powers of less than 100 watts, the underwriter's rules permit no. 14 wire of

solid copper. This size is practically as efficient as larger wire, but will not stand the pull that no. 12 or no. 10 will, and the underwriter's rules call for the latter for powers in excess of 100 watts if solid copper conductor is used.

More important from an electrical standpoint than the actual size of wire used is the soldering of joints, especially at current loops in an antenna of low radiation resistance. In fact, it is good practice to solder *all* joints, thus insuring quiet operation when the antenna is used for receiving.

Insulation. A question that often arises is that of insulation. It depends, of course, upon the r.f. voltage at the point at which the insulator is placed. The r.f. voltage, in turn, depends upon the distance from a current node and the radiation resistance of the antenna. Radiators having low radiation resistance have very high voltage at the voltage loops; consequently, better than usual insulation is advisable at those points.

Open-wire lines operated as nonresonant lines have little voltage across them; hence, the most inexpensive ceramic types are sufficiently good electrically. With tuned lines, the voltage depends upon the amplitude of the standing waves. If they are very great, the voltage will reach high values at the voltage loops, and the best spacers available are none too good. $\frac{3}{8}$ -inch Lucite rod, which can be purchased for 18c per foot, permits lightweight spreaders having excellent electrical properties. At the current loops the voltage is quite low and most anything will suffice.

When insulators are subject to very high r.f. voltages, they should be cleaned occasionally if in the vicinity of sea water or smoke. Salt scum and soot are not readily dislodged by rain, and when the coating becomes heavy enough, the efficiency of the insulators is greatly impaired.

If a very pretentious installation is to be made, it is wise to check up on both underwriter's rules and local ordinances which might be applicable. If you live anywhere near an airport and are contemplating a tall pole, it is best to investigate possible regulations and ordinances pertaining to towers in the district before starting construction.

CHAPTER TWENTY-ONE

U. H. F. Antennas

Antenna Requirements

The only difference between the antennas for ultra-high-frequency operation as compared with those for operation in other bands is in their physical size. The fundamental principles are unchanged. For this reason the reader interested in u.h.f. antennas should first study the discussion of antenna theory in Chapter 20.

Many types of antenna systems can be used for u.h.f. communication. Simple nondirective half-wave vertical antennas are popular for general transmission and reception in all directions. Point-to-point communication is most economically accomplished by means of directional antennas which confine the energy to a narrow beam in the desired direction. If the power is concentrated into a narrow beam, the *apparent* power of the transmitter is increased a great many times.

The useful portion of a signal in the u.h.f. region for short-range communication is that which is radiated in a direction *parallel to the surface of the earth*. A vertical antenna transmits a wave of low angle radiation and is effective for this reason, not because the radiation is vertically polarized.

Horizontal antennas can be used for receiving, with some reduction in noise. At points close to a transmitter using a vertical antenna, signals will be louder on a vertical receiving antenna. However, at distances far enough from the transmitter that the signal begins to get weak, the transmitted wave has no specific polarization and will appear approximately equal in signal strength on either a vertical or horizontal receiving antenna.

When used for transmitting, horizontal antennas radiate off the ends (in line with the wire) at too high a vertical angle to be effective for quasi-optical u.h.f. work. In fact, even the broadside radiation will be mostly at excessively high angles unless the

antenna is far removed from earth (10 or more wavelengths). However, by using several horizontal elements in an array which concentrates the radiation at low angles, results as good or better than with vertically polarized arrays of the same type will be obtained.

The antenna system for either transmitting or receiving should be as high above earth as possible and clear of nearby objects. Transmission lines, consisting of concentric lines or spaced two-wire lines, can be used to couple the antenna system to the transmitter or receiver. Nonresonant transmission lines are more efficient at these frequencies than those of the resonant type.

Feed Lines. Open lines should preferably be spaced closer than is common for longer wavelengths, as 6 inches is an appreciable fraction of a wavelength at $2\frac{1}{2}$ meters. Radiation from the line will be minimized if $1\frac{1}{2}$ -inch spacing is used rather than the more common 6-inch spacing.

It is possible to construct quite elaborate u.h.f. directive arrays in a small space; even multi-element beams are compact enough to permit rotation. For this reason, it is more common to employ directional arrays to obtain a strong transmitted signal than to resort to high power. Any of the arrays of Chapter 20 described in the section on directive antenna arrays can be used on 5 meters or $2\frac{1}{2}$ meters, though those with sharp, low angle vertical directivity will give the best results. Of the *simpler* types of arrays, those with their dipole elements vertical give the lower angle of radiation, and are to be preferred. When a multi-element stacked dipole curtain is used, little difference is noticed between vertical and horizontal orientation. The angle of radiation is very low in either case.

Effect of Feed System on Radiation Angle. A vertical radiator for general coverage u.h.f. use should be made either $\frac{1}{4}$ or $\frac{1}{2}$ wavelength long. Longer antennas do not have their maximum radiation at right

angles to the line of the radiator (unless co-phased) and therefore are not practicable for use where greatest possible radiation parallel to the earth is desired.

Unfortunately, a feed system which is not perfectly balanced and does some radiating not only robs the antenna itself of that much power, but *distorts the radiation pattern of the antenna*. As a result, the pattern of a vertical radiator may be so altered that the radiation is bent upwards slightly and the amount of power leaving the antenna *parallel to the earth* is greatly reduced. A vertical half-wave radiator fed at the bottom by a quarter-wave stub is a good example of this; the slight radiation from the matching section decreases the power radiated parallel to the earth by nearly 10 db.

The only cure is a feed system which does not disturb the radiation pattern of the antenna itself. This means that if a two wire line is used, the currents and voltages must be exactly the same (though 180 degrees out of phase) at any point on the feed line. It means that if a concentric feed line is used, the current flowing on the outside of the outer conductor of the line must be uniform, or better still, there should be no current flowing at all on the outside of the outer conductor.

Means for keeping the feed line out of strong fields where it connects to the radiator are discussed later in the chapter in descriptions of specific antenna systems. The unwanted currents induced in the feed line will be negligible when this precaution is taken.

Radiator Cross Section. In the previous chapter the statement was made that there is no point in using copper tubing for an antenna (on the medium frequencies). The reason is that considerable tubing would be required, and the cross section still would not be a sufficiently large fraction of a wavelength to improve the antenna characteristics. At ultra high frequencies, however, the radiator length is so short that the expense of large diameter conductors is relatively small, even though copper pipe of 1 inch cross section is used. With such conductors, the antenna will tune much more broadly, and often a broad resonance characteristic is desirable. This is particularly true when an antenna or array is to be used over an entire amateur band.

It should be kept in mind that with such large cross section radiators the resonant length of the radiator will be somewhat shorter, being only slightly greater than 0.90 of a half wavelength for a dipole when heavy copper pipe is used above 100 Mc.

The matter of using large diameter radiators should not be carried to ridiculous extremes, as detrimental eddy currents will be set up in the conductor. Also, there is little to be gained so far as broadening the resonance characteristic goes after a certain point is reached.

Insulation. The matter of insulation is of prime importance at ultra high frequencies. Many insulators that have very low losses as high as 30 Mc. show up rather poorly at frequencies above 100 Mc. Even the low loss ceramics are none too good where the r.f. voltage is high. One of the best and most practical insulators for use at this frequency is polystyrene (victron, etc.). It has one disadvantage, however, in that it is subject to cold flow.

It is common practice to so design ultra high frequency antenna systems that the various radiators are supported only at points of relatively low voltage, the best insulation obviously being air. The voltages on properly operated *untuned* feed lines are not high, and the question of insulation is not quite so important, though it still should be of good grade.

Polarization. Commercial stations in the U.S.A. favor horizontally polarized antennas for u.h.f. work, both for broadcasting and television. At the present time, however, amateur stations ordinarily use vertically polarized antennas and arrays. As previously mentioned, horizontal polarization results in less noise pickup at the receiver; however, vertical polarization produces greater field strength at relatively short distances.

Horizontally Polarized Arrays

With horizontal antennas and arrays there is little trouble with undesired currents being induced in the feed line from the field of the radiator. The currents induced in the feed system from the field of one half the antenna or array are cancelled by the currents induced by the field from the other half. The three-element close-spaced array, the W8JK flat top beam, the lazy-H, and the X-H array will give excellent results at ultra high frequencies when oriented for horizontally polarized radiation if a two-wire balanced feeder is used. Dimensions may be determined from the data given in the previous chapter by dividing the specified dimensions by the proper factor for a particular u.h.f. band. The feed line should be spaced somewhat closer than is conventional for lower frequencies. One and one-half inch spacing is

Figure 1.
U.H.F. W8JK ARRAY ORIENTED FOR VERTICAL POLARIZATION.

For data on this array, refer to preceding chapter. The stub and feed line should be equidistant from the two lower radiators.

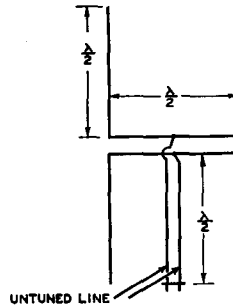
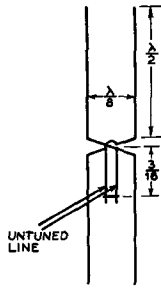

Figure 2.
H TYPE ARRAY ARRANGED FOR VERTICAL POLARIZATION.

The matching stub feeds the center of the phasing section instead of one end as in the case of horizontal orientation. The stub should be equidistant from the two lower radiators.

recommended for 112 Mc., and either 1 1/2 or 2 inch spacing is satisfactory for 56 Mc.

If large diameter conductors are used as the radiating elements, they must be shortened slightly from the calculated radiator lengths, as the figures given assume ordinary wire radiators.

As 224 Mc. and higher frequencies are not ordinarily used except for short distances, vertical polarization is generally to be preferred above 224 Mc.

Vertically Polarized Antennas and Arrays

Vertical arrays such as the W8JK and the Lazy-H (when the latter is fed in the center of the phasing section instead of at one end) will not produce undesired currents in the feed line if a two-wire feed system is used. Typical examples are shown in figures 1 and 2. The dimensions refer to electrical length. It is important that the stub and feed line be brought straight down for at least 2 wave lengths; if the stub or line is closer to one radiator than the other, undesired currents will be induced in the feed line.

For general coverage with a single antenna, a single vertical radiator is commonly employed. A two-wire open transmission line is not suitable for use with this type antenna, and low loss concentric feed line is to be recommended. Three practical methods of feeding the radiator with concentric line with a minimum of current induced in the outside of the line are shown in figure 3. Antenna A is known as the "Sleeve" antenna, the lower half of the radiator being a large piece of pipe up through which the concentric feed line is run. At B is shown the Brown ground plane vertical, and at C a modification of this same array. The arrangement shown at B is perhaps the most popular and easiest to construct.

The radiation resistance of the ground plane vertical is approximately 21 ohms,

which is not a standard impedance for concentric line. To obtain a good match, the first quarter wavelength of feeder may be of approximately 35 ohms surge impedance, and the remainder of the line of approximately 75 ohms impedance. Thus the first quarter-wave section of line is used as a matching transformer and a good match is obtained.

In actual practice the antenna would consist of a quarter-wave rod mounted by means of insulators atop a pole or pipe mast. Elaborate insulation is not required, as the volt-

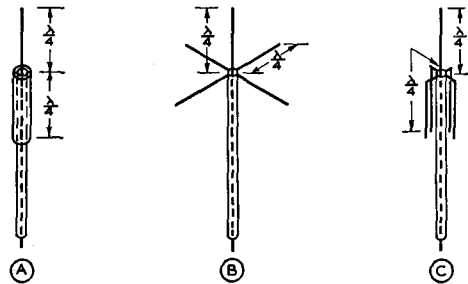

Figure 3.
THREE TYPES OF VERTICAL LOW ANGLE RADIATORS.

At A is shown the "sleeve" type coaxial radiator. The bottom half of the radiator consists of a piece of pipe up through which the coaxial cable runs. At B is illustrated the ground plane vertical, and at C a modification of this antenna.

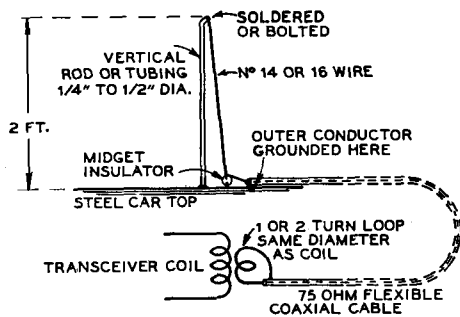

Figure 4.
HIGHLY EFFICIENT 112-MC. MOBILE
ANTENNA.

The coaxial cable should preferably be of the type having polystyrene insulation.

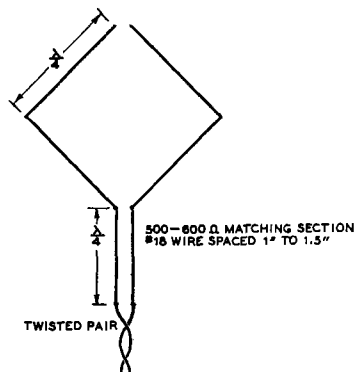

Figure 5.

D.F. ANTENNA SYSTEM FOR U.H.F.

In effect the antenna compares to two vertical close-spaced dipoles 180 degrees out of phase.

age at the lower end of the quarter-wave radiator is very low. Self-supporting quarter-wave rods would be extended out as in the illustration and connected together. As the point of connection is effectively at ground potential, no insulation is required; the horizontal rods may be bolted directly to the supporting pole or mast, even if of metal. The concentric line should be of the low loss type especially designed for u.h.f. use. The outside connects to the junction of the radials and the inside to the bottom end of the vertical radiator.

Mobile U.h.f. Antennas

For $2\frac{1}{4}$ - and 5-meter mobile work, either a quarter wavelength may be used as a Marconi against the car body, or a half wavelength may be used as a vertical dipole. The latter, while delivering a stronger signal, must be very well insulated at the base.

The Marconi type may be fed either with a single wire feeder tapped 28% up from the base or by means of coaxial line. Coaxial line constructed of copper tubing, with ceramic or polystyrene centering spacers holding the inner conductor, has the lowest loss. If single-wire feed is used, the Marconi antenna need not be insulated at the base. If coaxial line is used, a base insulator is necessary. However, the voltage at the base of a Marconi is quite low, and the insulation need not be especially good.

The coaxial line is connected across the base insulator; no tuning provision need be provided. The radiator length is adjusted for maximum field strength.

Coaxial line may be coupled to the transmitter or receiver by a one- or two-turn link.

The losses in *rubber-insulated* coaxial lines are relatively high at u.h.f.; but because only a short length is ordinarily required in a mobile installation, such a line is quite often used when the feeder must be run conveniently and inconspicuously.

An antenna that is highly recommended for 112 Mc. mobile work is illustrated in figure 4. It consists of a piece of tubing or rod between $\frac{1}{4}$ and $\frac{1}{2}$ inch diameter exactly 2 feet long, mounted vertically just above the center of the windshield atop the car, in about the same position as the auto radio antenna on some of the recent model Ford V-8 cars.

The bottom of the rod or tubing is bolted, welded, or otherwise fastened to the metal portion of the car. The tip of the rod is bent slightly so that when the parallel wire is fastened as shown in the illustration, the wire is held away from the rod sufficiently that it will not whip against the rod as a result of wind or vibration. The wire is anchored by means of a midget insulator, and pulled taut enough that the rod or tubing section bends slightly. Keeping the wire under slight tension will aid in preventing the wire from whipping against the grounded rod or tubing, which would cause the antenna to work erratically.

The outside conductor of the coaxial cable is soldered to the base of the vertical rod and the inner conductor is soldered to the bottom of the vertical wire where it fastens to the midget insulator. This insulator may be a $\frac{1}{2}$ inch dia. composition button similar to that on your coat sleeve, or a small piece of Lucite or Vietron drilled with two holes about a half inch apart.

U.H.F. Direction Finders

For locating a u.h.f. transmitter that is radiating either a horizontally or elliptically polarized wave, a simple horizontal dipole can be used as a direction finder. There will be fairly sharp nulls or minima off the ends of the horizontal radiator. When taking bearings, care must be taken to minimize pickup of reflected waves from surrounding buildings, etc.; otherwise an erroneous bearing will result.

When the polarization of the wave is predominantly or entirely vertical, the antenna illustrated in figure 5 is recommended. While this array may resemble a loop in mechanical construction, it is a tuned array and should not be considered as a loop antenna. In effect it is two close-spaced dipoles. When the array is turned broadside to the transmitting station, there will be a sharp null. The array is much more sensitive than a conventional loop antenna at u.h.f., and is therefore to be preferred. The whole array can be supported from a pole having a single cross arm, which can be made removable to make the array collapsible.

Microwave. D.F. Antennas. Microwave antennas are so small physically that a highly directive array can be contained in a small space. Any highly directive array can be used for direction finding. The arrangement of figure 5 will be satisfactory up to about 300 Mc. Above this frequency, a dipole equipped with a metal parabolic or angular flat sheet reflector is to be preferred. Such an array is rotated for maximum rather than minimum signal, and has the advantage of providing "sense" even though the accuracy may not be quite as high

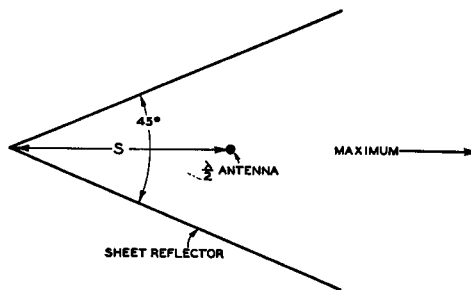

Figure 6.

DIPOLE WITH ANGULAR FLAT SHEET TYPE REFLECTOR.

This array has a very sharp "nose" and may be used for direction finding. It also has considerable gain over a dipole. For dimensions of reflector, refer to text.

as that of the various types working on nulls.

The angular flat sheet type reflector (also called "square corner" reflector) is easier to construct and provides better directivity than a parabolic reflector. One suitable for d.f. work is illustrated in figure 6. The sheets are the same height as that of the dipole and about 2 wavelengths on a side. The angle and side length are not critical, but the dipole should bisect the angle accurately. The distance S is approximately 1 wavelength. This array, in addition to being highly directional, provides considerable gain.

The dipole may be fed either with a delta matched open line (with very close spacing) or by means of 35 ohm coaxial cable.

CHAPTER TWENTY-TWO

Test and Measuring Equipment

There are certain pieces of test equipment that should be a part of every radio station and laboratory, in order to insure proper operation of radio receivers, transmitters, amplifiers and antenna systems, and to diagnose trouble when it occurs. Other pieces of test equipment, while very handy and undoubtedly desirable, are not absolutely necessary and may be considered somewhat of a luxury.

Every amateur should possess a simple volt-ohmmeter, absorption wavemeter and monitor. The last can be designed and calibrated to act as a frequency meter. How much additional test equipment an amateur is justified in acquiring depends upon the condition of his pocketbook, the amount of money otherwise invested in his station and his ingenuity and resourcefulness.

Some amateurs can diagnose trouble and determine whether their equipment is operating properly by means of a single meter, a few resistors and various parts from the junk box, though the job would undoubtedly be facilitated by a more extensive array of test equipment. Other amateurs, particularly those less technically inclined, will find more need for various special-purpose test instruments when trouble hunting or tuning up a transmitter; in fact, they will be helpless without such instruments.

Virtually everything in the way of test equipment of use to the amateur is described in this chapter. The units have been designed with simplicity and economy in mind, but not at the expense of reasonable accuracy or versatility.

Absorption-Type Wavemeter

The wavelength of any oscillator, doubler or amplifier stage can be roughly determined with the aid of a simple absorption wavemeter. It is particularly useful for determining the correct harmonic from a harmonic crystal oscillator or frequency doubler or quadrupler. It consists of a simple tuned circuit which is

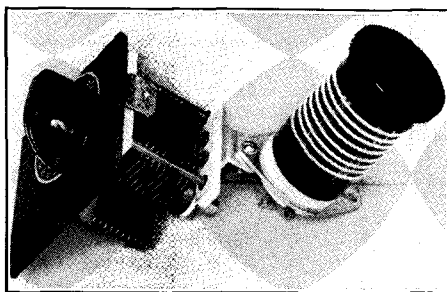

Figure 1.
SIMPLE ABSORPTION TYPE WAVEMETER.
This instrument is highly useful for identifying harmonics. Two plug-in coils cover from 8 to 95 meters. The meter is merely a calibrated tank circuit.

coupled to the tank circuit under measurement. The wavemeter absorbs a small amount of energy from the transmitter tank circuit; this produces a change in reading of the milliammeter in the plate or grid circuit. A sharp rise or dip in the milliammeter current reading will take place when the wavemeter is tuned to the same wavelength or frequency as that of the circuit under measurement.

The coil socket is bolted to the back mounting flange of the 140- $\mu\mu\text{fd}$. midget variable condenser. One coil covers from 8 to 30 meters, another from 30 to 95 meters. The coil turns should be held in place with duco cement.

Figure 2.
ABSORPTION WAVEMETER CIRCUIT.



For the range of from 8 to 30 meters, L should consist of 8 turns 1" long on a 1 $\frac{1}{4}$ " diameter form. For 30 to 95 meters, L should consist of 27 turns 1" long on a 1 $\frac{1}{4}$ " diameter form.

Figure 3.
FRONT VIEW OF THE FREQUENCY
SPOTTER.

The control to the left of the front panel is the trimmer on the 50-kilocycle oscillator. The right-hand control is the harmonic amplifier coil switch and the center control is the trimmer condenser across this coil.

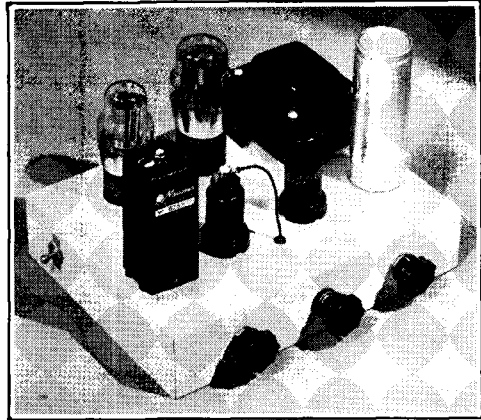

The wavemeter can be calibrated by holding it near the secondary coil of an ordinary regenerative receiver which tunes to the known amateur bands. As the wavemeter condenser is rotated through its range, a point will be found where the receiver is pulled out of oscillation, as indicated by a sharp click in the headphones of the receiver. This point is then marked on the scale of the wavemeter dial. This calibration is sufficiently accurate to insure transmitter operation in the 10-meter band rather than 13-meter operation, which can be easily mistaken for 10-meter output when tuning a transmitter.

The wavemeter can also be calibrated by holding it near the plate coil of a crystal oscillator. A change in oscillator plate current or even a cessation of oscillation will occur when the wavemeter is tuned to the same frequency as that of the oscillator.

One can either make a continuous calibration curve for the two coils or make notes of the dial settings for the various amateur bands.

Should a u.h.f. range be desired, the 56 and 112 Mc. bands can be covered with a 2 turn coil. However, Lecher wires are ordinarily used for measurement at these frequencies.

It should be borne in mind that the calibration of an absorption wavemeter is not sufficiently accurate for exact frequency determination. Its value is in permitting definite identification of harmonics.

Band Edge Frequency Spotter

The instrument diagrammed in figure 5 and pictured in figures 3 and 4 consists essentially of a 50-kilocycle oscillator and a tuned harmonic amplifier fed from a voltage-regulated power supply. It provides 50-ke. points of usable and adjustable strength on all the amateur bands up to and including 30 Mc. For that matter it also gives usable calibration points every 50 ke. on the frequencies in between the amateur bands should they be needed for some special purpose.

The 50 Kilocycle Oscillator. A 6K8 tube is used as a combined 50-kilocycle oscillator and electron-coupled doubler to 100 kc.

The oscillator coil is a Meissner 456-kilocycle beat-oscillator unit with the mica trimmer removed. By loading this compara-

tively high-frequency coil to the low frequency of 50 kc., the oscillator tuned circuit becomes quite high C. The stability with respect to tube and circuit temperature variations and plate voltage variations is greatly improved by the high oscillator lumped capacity. Actually, the capacity required to tune this oscillator coil to 50 kilocycles is very close to 0.00625 microfarads. This capacity is obtained through the use of a .006- μ fd. fixed condenser of the silver-plated mica type in parallel with a .0002- μ fd. negative coefficient condenser of the ceramic type and a 100- μ fd. midget variable. It is important that the identical coil as shown in the Buyer's Guide be used (and that the mica trimmer thereon be removed) if the values of capacity shown are to hit 50 kilocycles. It is also important that the specified type fixed condensers be used for lump capacity.

The 100- μ fd. midget trimmer condenser is brought through the chassis and allows the frequency of the oscillator to be tuned about one-half kilocycle either side of the operating frequency of 50 kilocycles. This adjustment will ordinarily compensate for any small variations in coil inductances and in circuit capacity. If, however, it is impossible to tune this circuit to 50 ke. by a variation in the capacity of this condenser, the addition or subtraction of .00005 μ fd. from the fixed value of .00625 will usually allow it to be accomplished.

The oscillator coil, as it comes from the manufacturer, is not a single tapped unit but rather a two-winding affair with four leads brought out from the coils. It will then be necessary to series these two coils as shown in the manufacturer's diagram as the connection for an electron-coupled oscillator. The cathode of the oscillator-mixer tube is then connected to the tap. The actual connections

to the coil are as follows: blue wire, ground; green wire, grid; red and black connect together and go to cathode.

The Harmonic Amplifier. The output circuit of this stage consists of a tapped coil which is resonated by a $100\text{-}\mu\text{fd}$. midget variable. With the whole coil in the circuit the output can be peaked at any frequency from about 7500 ke. down to about 3500 ke. Nevertheless, there is ample output with this coil in the circuit down through the broadcast band. It is not necessary to resonate the output circuit at these low frequencies; there is more than ample output for all measurements and for calibration.

With the switch in the second position all but 9 turns of the inductance are shorted and the coil will resonate at any frequency from about 7000 ke. down through 18,000 ke. This tap peaks in the middle of the dial for strong signals on the 14-Mc. band. With the switch on the last tap, with only four turns in the circuit, the circuit peaks up in the 28-Mc. band and for a considerable distance either side of it.

Coupling of the output circuit to the external load is accomplished by means of a $.000025\text{-}\mu\text{fd}$. mica condenser which connects between the plate of the 6V6 and the output terminal. The decrease in the reactance of this condenser with increasing frequency tends to equalize the signal strength output of the unit over a wide range of frequency.

A simple resistance-capacity filtered power supply using an 80 rectifier is used for plate

voltage to the unit. Ample filtering for the harmonic amplifier stage is attained through the use of the RC filter. The VR-150-30 voltage regulator with its associated resistors and condensers supplies very pure direct current to the 6K8 oscillator and first multiplier.

Tuning Up and Calibration. If the oscillator coil specified has been used and if the exact values of capacity specified have been placed across the coil it is only necessary to get the oscillator going on the proper frequency of 50 kilocycles; when this is once done, all other adjustments become very simple.

For tuning up the frequency spotter the only additional piece of equipment required is a calibrated broadcast receiver and a few incoming broadcast signals on frequencies that are integral multiples of 50 ke. With the oscillator operating (with the output coil on the no. 1 tap—all the coil in the circuit) run a wire from the output terminal of the spotter to the antenna post on the b.c.l. set and connect a small external antenna to the receiver.

With the trimmer condenser in the oscillator set to about mid-scale, tune the b.c.l. set to the low-frequency end of the dial and pick up the first harmonic of the oscillator that can be tuned in. Mark down the frequency of this harmonic as determined from the calibration of the b.c.l. set. Then tune to the next harmonic (they will be easy to identify because of their lack of modulation) and mark down its frequency as again determined from the b.c.l. set. Keep doing this until 8 or 10 points

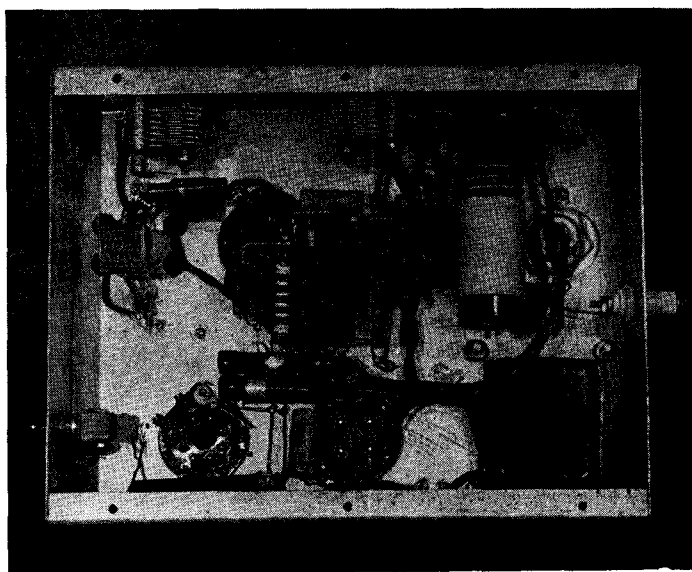

Figure 4.

BOTTOM VIEW OF THE CHASSIS SHOWING PLACEMENT OF COMPONENTS.

The tapped amplifier output coil is to the right and the r.f. choke with the two paralleled condensers across it comprising the plate circuit of the 6K8 is just to the left of the center of the chassis.

are determined. Then subtract each frequency from the next higher one all the way down the line and average the resulting differences in frequency between the harmonics. If any one of the differences falls very far out of line, recheck its frequency to see if an error has been made or to see if a harmonic has been missed.

If the average of all the differences in frequency falls very near to 50 kilocycles (say 48 to 52 kc.) the unit is ready for calibration. If not the values of padding condenser across the oscillator coil will have to be changed.

When the oscillator has been adjusted very closely to 50 kc. by the "difference-between-harmonics" method, pick out a broadcast station that is operating on some multiple of 50 kc.; one in the vicinity of 550 to 1100 kc. will be the best. Tune in this station, turn on the oscillator, and adjust the beat between the harmonic of the oscillator and the broadcast station to zero. Then find another b.c. station on a harmonic of 50 kc. and see if it also is at zero beat. If the second b.c. station is not at zero beat or within a few cycles of it, the oscillator definitely isn't on 50 kc. and the frequency will have to be rechecked by the procedure given in the preceding paragraphs,

fixed condensers being added or subtracted depending on whether the frequency is high or low.

If the second station is at zero beat with the harmonic, check with a few more stations on multiples of 50 kc. just to make sure all is well. As mentioned before, if the values and components given are used it will only be necessary to adjust the trimmer condenser across the oscillator tank, which is brought out to the front panel, to hit 50 kc. and thereby arrive at this stage of the adjustment.

It will now only be necessary to set the trimmer condenser so that the harmonics in the broadcast band fall exactly at zero beat with the b.c. stations and the unit will thenceforward be calibrated.

It will be found that strong, steady signals are available every 50 kilocycles throughout all the amateur bands from 160 through 10 meters. These signals can be used as band-edge markers for either the phone or c.w. bands. Or, if a receiver with substantially straight-line-frequency tuning and an accurate dial is in use, the frequency of any incoming or locally-generated signal may be determined to a good degree of accuracy by interpolating between the 50-kilocycle points.

Figure 5.
WIRING DIAGRAM OF THE FREQUENCY SPOTTER.

- C₁, C₂—100- μ fd. midget variable
- C₃—.006- μ fd. silvered mica (close tolerance)
- C₄—.0002- μ fd. negative coefficient ceramic capacitor
- C₅—.0005- μ fd. midget mica
- C₆, C₇—0.1- μ fd. 400 volts
- C₈—.001- μ fd. mica
- C₉—.0001- μ fd. mica
- C₁₀—.001- μ fd. mica
- C₁₁—0.1- μ fd. 400 volts
- C₁₂—.01- μ fd. midget mica
- C₁₃—25- μ fd. midget mica
- C₁₄, C₁₅—8-8- μ fd. 450-volt elect.
- R₁—100,000 ohms, 1 watt
- R₂—25,000 ohms, 2 watts
- R₃—2 megohms, 1 watt
- R₄—50,000 ohms, 2 watts
- R₅—20,000 ohms, 10 watts

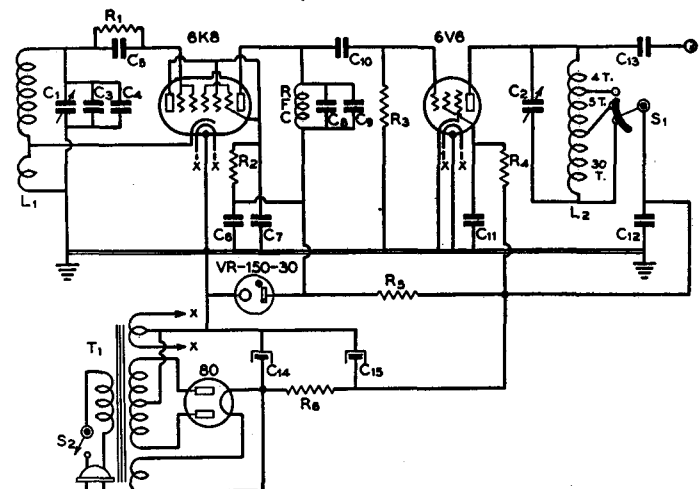

- R₆—10,000 ohms, 10 watts
- S₁—Shorting type 1-pole 3-position switch
- S₂—S.p.s.t. a.c. line switch

- L₁—456-ke. b.f.o. coil with trimmer removed
- L₂—39 turns no. 20 d.c.c. on 1" dia. form tapped at 9 and 4 turns; last 4 turns

- spaced RFC—2.1-mh., 125-ma. r.f. choke
- T₁—650 v. c.t., 40 ma.; 6.3 v. 2 a.; 5 v. 2 a.

The warm-up time of the unit is very short, a matter of only five minutes or so, due to the very high value of capacity in the 50-kilocycle oscillator tank. Once the oscillator has been set it will not drift more than a few cycles on the broadcast band (less than 100 cycles on ten meters) in many hours of continuous operation. However, each time the unit is placed into operation from a cold start it will be best to check the setting of the oscillator trimmer condenser against a broadcast station on a multiple of 50 kc. after allowing five minutes or so to warm up.

Dual Frequency Crystal Calibrator

At a reasonable price it is possible to purchase a crystal unit containing a crystal which will oscillate on either 100 or 1000 kc., oscillating along its length for the lower frequency and through its thickness for the higher frequency. The accuracy of the 100 kc. oscillation is very high, when installed and adjusted in a calibrator of the type to be described, thus permitting precision frequency measurement.

The advantage over the 50-kc. self-controlled unit just described is that it is much simpler to get going initially and one need not allow for warm up or check it each time before taking a measurement. It has the further advantage that it can be made to oscillate with reasonable accuracy (.05%) at 1000 kc., which is of considerable help in identifying the 100 kc. points on the higher

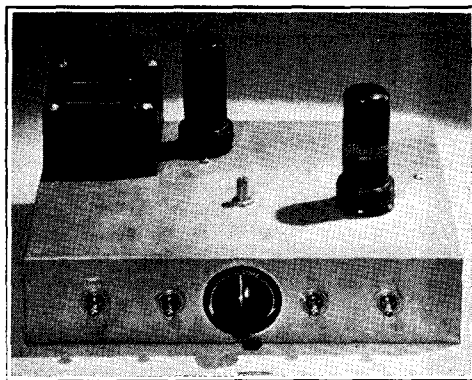

Figure 6.
DUAL FREQUENCY CRYSTAL
CALIBRATOR.

This instrument generates 1000 kc. harmonics up to 56 Mc. and 100 kc. harmonics up to 20 Mc., the latter with a high degree of accuracy. On the front of the chassis is the output control; the slotted shaft projecting out of the top of the chassis is a shunt trimmer across the crystal for adjusting the low frequency oscillations precisely to 100 kc.

frequencies where it is sometimes difficult to determine the order of a particular 100 kc. harmonic. The only disadvantage is that the 100 kc. points are twice as far apart as the points given by the "Band Edge Spotter" previously described, and the strength of harmonics above 14 Mc. is not quite as great with the crystal calibrator, due to the lack of a separate harmonic amplifier.

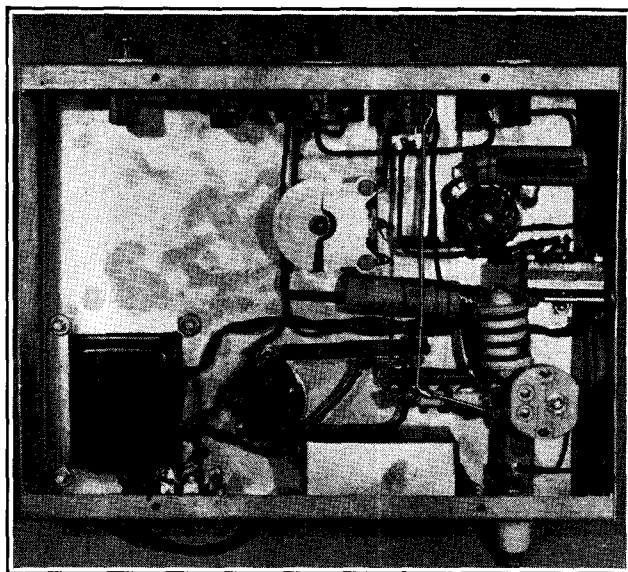

Figure 7.
UNDER-CHASSIS VIEW OF THE
CRYSTAL CALIBRATOR.
The crystal unit is mounted close to
the 6F6 sockets. Power supply components
are to the lower left.

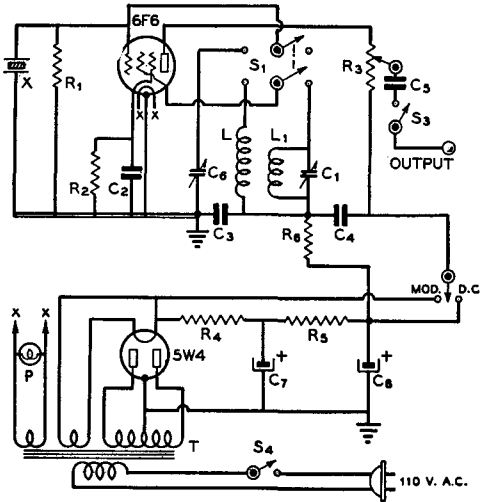

Figure 8.

WIRING DIAGRAM OF CRYSTAL CALIBRATOR. (as recommended by Bliley Electric Co.)

X—100 and 1000 kc. crystal calibrator unit	C ₇ , C ₈ —Dual 4- μ fd. 450-volt electrolytic
R ₁ —5 meg., 1/2 watt	T—320 v. each side of c.t., 40 ma. and fil. windings
R ₂ —500 ohms, 1 watt	S ₁ —D.p.d.t. toggle switch
R ₃ —0.5 meg. potentiometer	S ₂ —S.p.d.t. toggle switch
R ₄ —10,000 ohms, 1 watt	S ₃ —S.p.s.t. toggle switch
R ₅ —20,000 ohms, 1 watt	L—R.F.C., exactly 8 mh.
C ₁ —25-100 μ fd. mica trimmer	L ₁ —Pie wound 2.1 or 2.5 mh. 125 ma. r.f. choke with all sections except one removed
C ₂ , C ₃ , C ₄ —0.1- μ fd. tubular	
C ₅ —0.01- μ fd. mica	
C ₆ —25- μ fd. midget variable	

It should be borne in mind that the accuracy of the crystal when oscillating on 1000 kc. is not supposed to be sufficient for precision measurements; it is simply for convenience in identifying the highly accurate 100 kc. points.

Construction. The only precautions to be observed in construction are to place the crystal away from any components which radiate heat, and to make the leads from the tube to the crystal as short as possible. Mounting the crystal under the chassis close to the 6F6 socket as illustrated meets these requirements. The leads to condenser C₆ should also be kept as short as possible.

The coil L₁ is one pie of a midget 125 ma. 2.1 or 2.5 mh. r.f. choke. If the crystal will not oscillate with the switch on 1000 kc. position, it may be necessary to remove a few turns from the coil. A midget solenoid b.c.l. coil may be substituted if desired.

Adjustments and Use. First check for oscillation on both positions of S₁ to make sure the crystal will oscillate both on 1000 and 100 kc. If it does not oscillate on 1000 kc., then the mica trimmer C₁ should be varied. When this trimmer has once been adjusted so that the crystal "comes on" every time the switch is thrown, the trimmer need never be touched again.

The 100 kc. frequency should then be precisely adjusted by means of the 25- μ fd. air trimmer C₆ until harmonics of the 100 kc. oscillator zero beat *exactly* with broadcast stations on multiples of 100 kc. Zero beat can most accurately be determined if the receiver has a tuning eye or "R" meter. The trimmer is first adjusted as close as possible by ear and then further adjusted until the "flutter" of the indicator is reduced to as low a frequency as possible. The adjustment should preferably be checked against three or four broadcast stations and an average taken if there is any deviation for the different stations. No modulation should be applied to the oscillator during this adjustment.

The calibration when thus obtained will hold over a long period of time, and it is not necessary to check the frequency against broadcast stations before taking a measurement so long as the room temperature does not vary too much from the temperature at which the instrument was originally calibrated.

Modulation is accomplished by applying unfiltered r.a.c. to the output circuit of the oscillator, and can be cut in or out by means of the s.p.d.t. toggle switch indicated. The modulation facilitates spotting of the harmonics by making it easier to pick them out from among stray carriers.

Care should be taken with any 50 kc. or 100 kc. oscillator when making measurements on 14 Mc. or above if the receiver used does not have good image rejection. The appearance of images will result in spurious carriers and false readings.

Diode-Type Field-Strength Meter

The most practical method of tuning any antenna system, such as a half-wave antenna or a directional array, is by means of a field-strength meter. This instrument gives a direct indication of the actual field strength of a transmitted signal in the vicinity of the antenna. The device consists of a tuned circuit and a diode rectifier which is connected in series with a microammeter so that the meter will read the carrier signal strength.

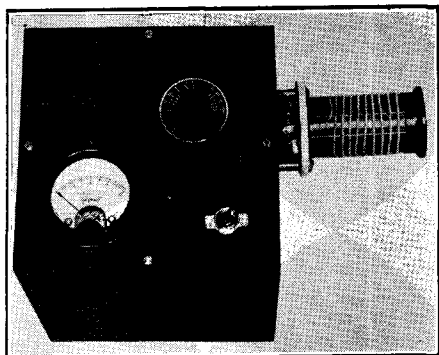

Figure 9.

SIMPLE FIELD STRENGTH METER.

This field strength meter uses a type 30 connected as a diode; a 0-100 or 0-200 microammeter provides good sensitivity. The unit can be used as an absorption wavemeter if calibrated. It can also be used as a neutralizing indicator.

A 0-200 microammeter as an indicator provides higher sensitivity than can be obtained with the more common 0-1 ma. meter ordinarily used for this purpose. A 0-100 microammeter will give still greater sensitivity.

The unit is inexpensive and requires but a single 1½-volt cell for power. Besides serving as a field-strength meter, it can be

Figure 10.
WIRING DIAGRAM OF THE SIMPLE FIELD STRENGTH METER.

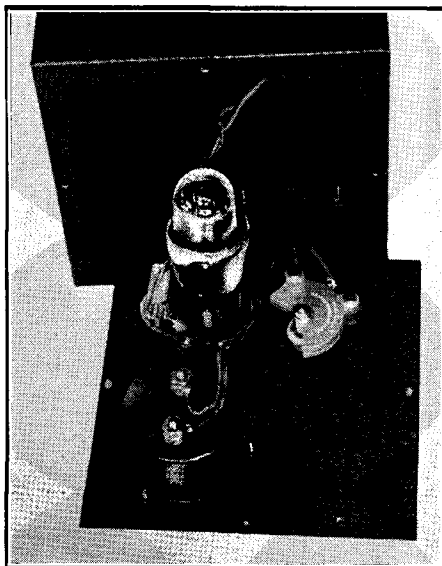
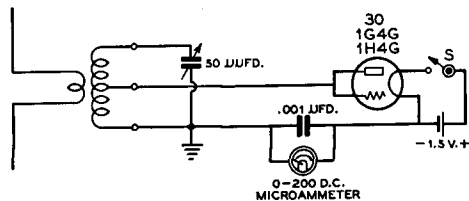

Figure 11.

INTERIOR VIEW.

Few components are inside the can housing the diode-type field strength meter. A single "little six" dry cell is strapped inside the cabinet and supplies 1½ volts to the filament of the type 30 tube, used as a diode rectifier.

used as a neutralizing indicator or calibrated for use as an absorption wavemeter. The entire unit, except coils and coil socket, is housed in a metal can 6" square. The externally mounted coil facilitates coil changing and better adapts the unit for use as a wavemeter, no antenna or pickup wire being necessary in this application.

For service as a field-strength meter, the coil can be coupled to a small doublet by means of two or three turns of insulated wire wound around the coil. The instrument will be most sensitive if the pickup doublet is

COIL TABLE.

160 λ	88 turns #26 d.c.c. 1½" diam. closewound center tap	20 λ	10 turns 22 d.c.c. 1½" diam. 1½" long center tap
80 λ	38 turns 22 d.c.c. 1½" diam. closewound center tap	10 λ	6 turns #22 d.c.c. 1⅜" diam. 1" long center tap
40 λ	24 turns #22 d.c.c. 1½" diam. 1½" long center tap	5 λ	2 turns #18 enam. 1⅜" diam. ¾" long center tap

made resonant; but such a resonant doublet may, if it is closer than two or three wavelengths, upset the operation of the antenna being adjusted.

The instrument (figure 9) was checked against a signal generator. With a type-30 tube, the following calibration in terms of decibels was obtained, using $12\frac{1}{2}$ μ a. as an arbitrary zero db reference level:

$12\frac{1}{2}$ μ a.—0 db	100 μ a.—15 db
25 μ a.—5 db	150 μ a.—18 db
50 μ a.—10 db	200 μ a.—20 db

High-Sensitivity Field-Strength Meter and Simple V.T. Voltmeter

When it is desired to make field strength readings some distance from the antenna, especially when a low-powered transmitter is used, the diode-type field meter just described does not have sufficient sensitivity. For this purpose a more sensitive device is required. The field strength meter illustrated is considerably more sensitive, but requires a plate battery and a more expensive tube than the diode type previously described.

A 1B4 tube, triode connected, is used as a detector. Two small batteries are required for the plate, filament and bias supplies. The plate voltage is $22\frac{1}{2}$ volts, the bias about 2 $\frac{1}{2}$ volts and the rated filament voltage, 2 volts.

The one tuned circuit in the meter is designed to cover any two consecutive amateur bands.

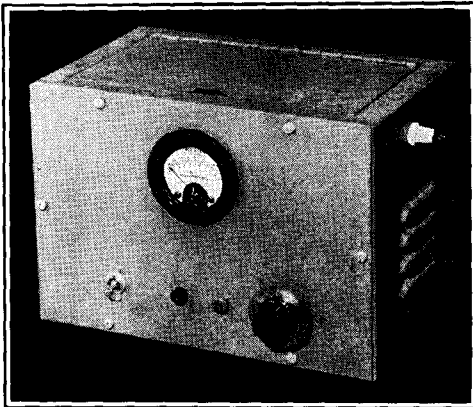

Figure 12.

SENSITIVE FIELD STRENGTH METER.

This device is more sensitive than the one illustrated in figures 9, 10 and 11, and also has the advantage of being usable as a simple vacuum tube voltmeter. However, it requires more batteries.

In the unit shown, one coil is used to cover 10 and 20, another to cover 40 and 80, and still another coil to cover the 160-meter band. All coils are wound on $1\frac{1}{2}$ "-diameter coil forms.

The 10-20-m. coil contains 4 turns spaced to about $\frac{3}{4}$ "; the 40-80-m. coil is of 15 turns closewound, and the 160-m. coil is of 50 turns, closewound. All coils are wound with no. 20 wire; the 10-20 one is wound with enamelled

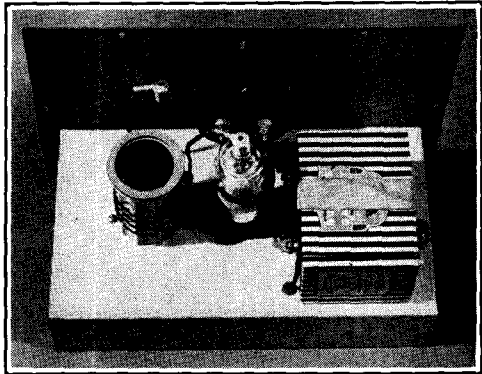

Figure 13.

REAR VIEW OF SENSITIVE FIELD STRENGTH METER.

The plate battery is mounted above the chassis, held firmly in position by means of a strap. Note the extra grid clip, which is brought out to a pin jack for v.t. voltmeter use.

and the other two with d.c.e. Both of the two-band coils (10-20 and 40-80) will hit the lower-frequency band with the condenser plates almost completely meshed, and the higher frequency band with them almost separated.

When the unit is first turned on, if the batteries and the tube are in good condition, the 0-1 d.c. milliammeter in the common plate and screen circuit of the 1B4 will indicate about 50 microamperes of plate current.

Now, to return the meter to the zero position, with this .05 ma. flow going through it, it is only necessary to turn the zero-adjustment screw until the needle points to zero with the meter in operation. Then, the fact that the meter will always point to zero when all components are in adjustment will serve as a check on the calibration and condition of the batteries. However, as soon as the meter is turned off, the pointer of the milliammeter will fall below the zero on the scale. (Actually it will rest upon the pin on the zero side of the meter.)

If a short length of wire is used for pickup, it may be connected directly to the antenna

post, which is a standoff insulator on the side of the cabinet, wired directly to the stator of the tuning condenser. If it is impossible to get a substantial deflection with a short length of wire, the case of the instrument should be grounded and a longer piece of wire connected to the antenna post through a 3-30 $\mu\mu$ fd. mica trimmer used as a pickup. If the trimmer is not used, a long pickup antenna will detune the meter.

The tuning condenser C_1 can be detuned from resonance if too great a deflection is obtained. It is not necessary that the tank be tuned to resonance for field-strength

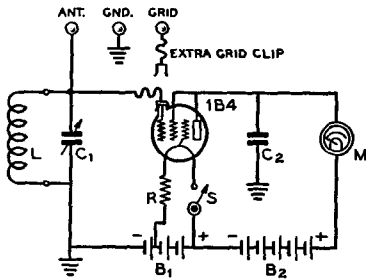

Figure 14.

WIRING DIAGRAM OF SENSITIVE FIELD STRENGTH METER.

- C_1 —140- $\mu\mu$ fd. midget variable
- C_2 —.002- μ fd. mica
- R—15-ohm resistor
- S—On-off switch, s.p.s.t. toggle
- M—0-1 d.c. milliammeter (2" size to use chart given)
- B_1 —4½-volt C battery. Filament leads connected to + and - 3, ground connected to - 4½
- B_2 —22½-volt C battery
- L—Coils—see text

measurements, though the meter will be most sensitive when C_1 is tuned to exact resonance.

For most work, calibration is not required, a relative indication being sufficient. However, the dial may be calibrated in decibels if desired. The decibel calibration may be marked directly on the meter scale, or a calibration chart may be made. To calibrate the instrument in decibels, simply reduce the input to a class C amplifier in given steps after adjusting the f.s. meter for full scale deflection. Cutting the plate voltage to the class C stage in half would be a power reduction of four times, or 6 db, and so on. The meter covers a useful range of approximately 20 db.

If the instrument is used as a wavemeter, the dial calibration should be made with a short, rigid piece of wire as a pickup. The same wire should then be used whenever subsequent wavelength measurements are made.

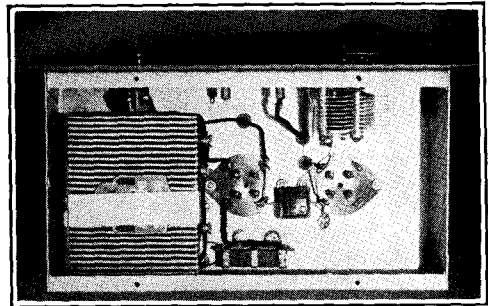

Figure 15.

UNDER-CHASSIS VIEW OF SENSITIVE F.S. METER.

The combined "A" and "C" battery is strapped under the chassis as shown here.

This wire or rod need not be over a few inches long, as it will receive sufficient pickup when brought near the tank circuit whose frequency is to be determined.

For simple vacuum tube voltmeter measurements it is only necessary to substitute the extra grid clip and make connections from the pin jacks to the device whose voltage is to be measured.

When used as a v.t. voltmeter the instrument should be calibrated by means of an adjustable a.c. voltage supply of 0-5 volts and a 5 volt a.c. voltmeter. If desired, the voltage calibration can be converted to decibels, thus making it unnecessary to calibrate it by the method previously described.

Grid Leak F.S. Meter

Slightly greater sensitivity and decibel range can be obtained with a grid leak type f.s. meter than with the power detector type just described. However, it requires a higher voltage plate battery and has the disadvantage that it cannot be used as an accurate v.t. voltmeter. But if the transmitter power is low or if readings must be taken at considerable distance, the grid leak type is to be preferred. It will give usable readings on approximately 10 db weaker signals than will the power detector type.

The instrument illustrated in figure 16 and diagrammed in figure 17 utilizes a type 19 dual triode for maximum power sensitivity, though any 1.5 volt or 2 volt triode having a μ between 20 and 50 will be satisfactory if the plate voltage is changed accordingly. The plate voltage should be just sufficient to make the tube draw very close to 1 ma. when no excitation is applied. The meter is then adjusted to exactly 1 ma. by means of

the zero adjuster screw. A signal will cause a *deflection* in plate current, the amount of *deflection* increasing with an increase in signal input voltage up to a saturation point corresponding to about 0.25 ma. scale. To make the meter pointer read forwards with increased signal strength, the meter is mounted upside down.

The instrument illustrated can be used from 10 to 160 meters. For 5 and 2½ meters, an HY-114 should be substituted for the 19 or 1J6-G, and a 15-μμfd. sub-midget variable should be substituted for C. The mechanical arrangement should be changed to allow shorter tank circuit leads for 5 and 2½ meters. The required plate voltage for a no signal plate current of 1 ma. will be about the same as for a 19, or about 50 volts.

The required voltage must be obtained by changing the plate battery voltage, adding in 1½ volt steps if necessary, to get the required voltage. A variable dropping resistor in the plate voltage lead is not satisfactory, as the voltage drop through this resistor will decrease as the plate current decreases, thus reducing the sensitivity of the instrument.

A fairly accurate calibration may be obtained by using the accompanying calibration chart, provided a type 19 or 1J6-G is used.

Assuming the meter has 50 scale divisions, start counting from zero signal or 1 ma. and mark the meter face in pencil to correspond to the calibration chart. (With 50 scale divisions, 1 division is equal to 20 ua. or .02 ma.)

If greater accuracy is required, the meter should be calibrated individually as described for the meter of figure 12.

Care should be taken with the 0-1 ma. meter when installing it to make sure the negative meter terminal isn't accidentally shorted to ground (by the pliers or screwdriver touching the cabinet, or other means). The meter will be blown instantly by the B voltage if this happens. It is best to disconnect the B plus lead to the plate battery when connecting or disconnecting leads to the meter. A

Scale Divisions	Db Calibration
3	0 db
5	3 db
8	6 db
12	9 db
17	12 db
22	15 db
27	18 db
31	21 db
34	24 db
36	27 db

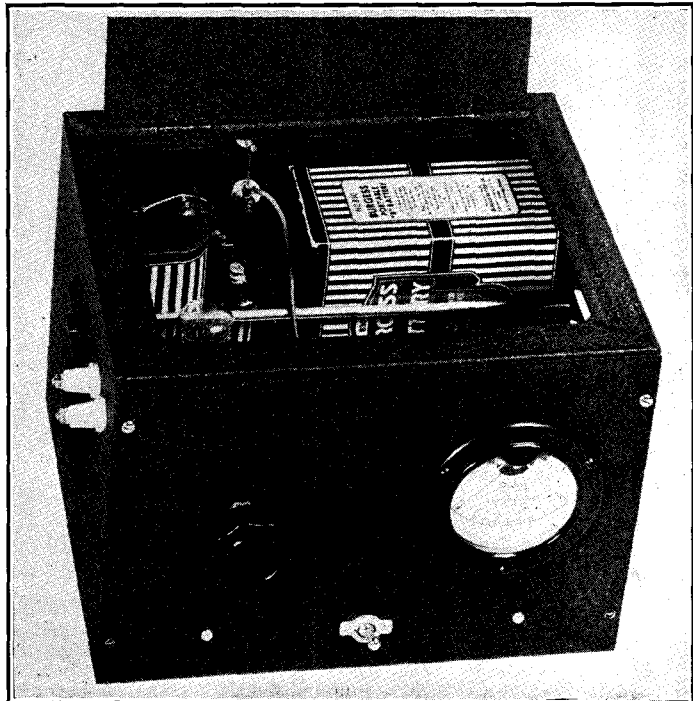

Figure 16.

HIGHLY SENSITIVE, GRID LEAK TYPE F.S. METER.

Note inverted method of mounting the 0-1 milliammeter and hand calibrated db scale. Doublet feeder terminals are on side of cabinet, antenna terminal on rear of cabinet to reduce body capacity.

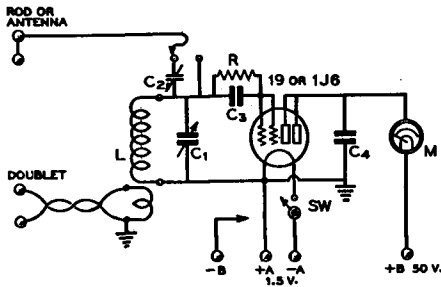

Figure 17.

GENERAL WIRING DIAGRAM OF THE F.S. METER.

The B minus is connected to that side of the A battery which gives a plate current reading closest to 1 ma. with the plate meter inverted. Be sure a positive is connected to chassis (ground).

- | | |
|---|---|
| L—See coil table | C ₄ —.001- μ fd. midget mica condenser |
| C ₁ —50- μ fd. midget condenser for 5-40 meters (25- μ fd. for 2½-20 meters) | M—0-1 ma. 3 in. round (bakelite) case milliammeter |
| C ₂ —3-30- μ fd. mica trimmer | R—Accurate 5-megohm ½-watt resistor |
| C ₃ —.0005- μ fd. midget mica condenser | |

small, instrument type fuse in series with the meter is desirable for protection.

It should be borne in mind that this f.s. meter has a "saturation point," beyond which the deflection flattens off and then actually decreases with further increase in signal strength. In taking a reading, care should be taken to make sure the signal is not so strong as to block the meter, as a deceptive indication then will be obtained. De-tuning the tank condenser from resonance should always result in less signal strength; if this does not occur, the signal is blocking the f.s. meter and it must be cut down before a reading can be taken.

Diode Peak Voltmeter

Few amateurs have need for a slide-back type vacuum tube voltmeter; hence none is shown here. If the reader should be interested in such a device, he is referred to the one described in the current RCA Receiving Tube Manual (technical series). For all ordinary purposes the simple, combined f.s. meter and v.t. voltmeter just described can be used for measuring a.f. and r.f. voltages of only a few volts, and the simple instrument to be described can be used for measuring voltages over 5 or 10 volts.

By using a 0-100 microammeter, it is possible to construct a rectifier-type voltmeter

of approximately 5000 ohms per volt (a.c. impedance). Such a meter subjects a circuit to so little loading that it can be used in place of a v.t. voltmeter for all ordinary measurements.

A schematic circuit of the voltmeter is shown in figure 19. The device consists of two parts: A measuring head, comprising a 6H6 diode with both plate leads brought out and a 0.01 microfarad by-pass condenser (preferably mica), connected by a three-wire shielded cable to the heater supply, microammeter, multiplying resistor and by-pass condenser. The 1.0 megohm resistance together with a 100 microampere meter will give a 10 to 100 volt range; addition of another 4 megohms, making a total of 5 megohms, will extend the range up to 500 volts, peak. The heater supply may be direct or alternating current, preferably a.c. from a separate filament transformer.

The shell of the 6H6 diode—to which is tied the cable shielding—forms the ground side of the voltmeter and must be connected to the grounded side of the radio-frequency potential under measurement, thus completing the d.c. path which is necessary in order to obtain an indication with the instrument. Both anodes of the 6H6 diodes are brought out, making possible the equal loading of balanced-to-ground circuits, provided these circuits have their center-point available and provided it is connected to the terminal "G" of the voltmeter. The voltmeter reads the



Figure 18.

DIODE PEAK VOLTMETER.

This voltmeter is accurate on frequencies up to 30 Mc. Its small size makes it possible to get into tight places. Its a.c. impedance is approximately 5000 ohms per volt.

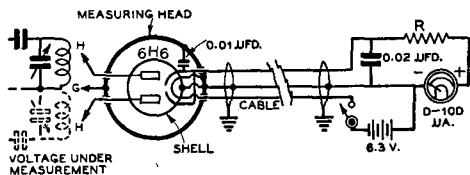

Figure 19.

DIODE PEAK VOLTMETER CIRCUIT.

The resistor R should be 1 megohm for 100 volt scale, and 5 megohms for 500 volts full scale (peak voltage). If direct reading is desired (instead of a calibration chart), the value of R should be reduced about 5 per cent, or until the meter reads exactly full scale at 100 and 500 volts peak.

same whether one or both anodes are used with such circuits; namely, the peak voltage between one anode and ground is indicated.

Voltage measurements, in most instances, are made across a tuned circuit, the inductance furnishing the required d.c. path. Even if there are supply voltages fed through the tuned circuit, this method of connection is feasible. Since the entire voltmeter circuit is then at the supply voltage above ground, due caution must be exercised.

Calibration. A 60 cycle per second calibration of the voltmeter will remain valid up to radio frequencies of the order of 30 megacycles per second. For this power-frequency calibration, the by-pass capacitance should temporarily be paralleled with a 10-microfarad paper condenser. Experiment shows that the relation between the microammeter deflection and the applied peak voltage is strictly linear. Thus, a one-point calibration is often sufficient; but for greater precision it is desirable to apply calibrating voltages of variable amplitude, such as obtained from the secondary of a power-pack transformer, measuring the voltage with a suitable 60 c.p.s. meter. The r.m.s. voltage times 1.41 gives the peak value, and this should be used as abscissa of the plot, with the microammeter deflection as ordinate. The small space current which exists without applied voltage, due to the initial electron velocity, should be subtracted from all readings; this can be done conveniently by setting the microammeter needle to zero with the heater energized, but without applied voltage.

If good quality, close tolerance multiplier resistors are used, and an extremely high degree of accuracy is not required, the meter need not be individually calibrated. The multiplier resistance \times the microammeter reading \times 0.95 gives the peak voltage under measurement. So in this case the value of R should be reduced 5% from that specified

(to make the meter direct reading). Then the meter will read full scale at 100 or 500 peak volts, instead of 0.95 full scale.

The input impedance of the voltmeter is approximately that of a 1.5-micromicrofarad capacitance paralleled with an effective a.c. resistance equal to one half the multiplier resistance.

A.C. Frequency Meter-Monitor

An accurate means for determining the frequency of a radio transmitter is essential when the circuit is of the self-excited oscillator type. The same device is useful for checking quartz crystal transmitters in order to make certain that the crystal is not oscillating on a spurious frequency.

The frequency meter consists of a very stable electron-coupled oscillator which is accurately calibrated. This same unit serves as a c.w. monitor. The oscillator covers the 80 meter amateur band, and harmonics of these frequencies are used for measurements in the higher frequency bands.

The oscillator has a small tuning condenser shunted by a larger, bandsetting condenser; the latter is adjusted only when the frequency meter is calibrated from standard frequency transmissions or broadcast station harmonics in conjunction with a calibration oscillator.

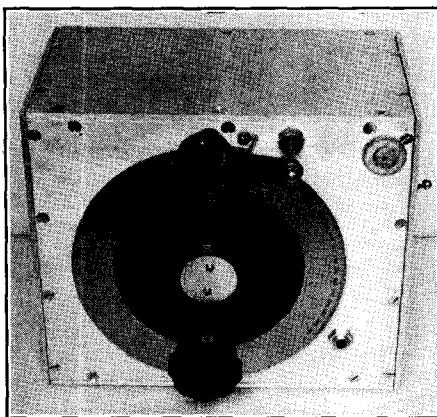

Figure 20.

HETERODYNE FREQUENCY METER.

Heterodyne frequency meter with an audio amplifier stage following the electron coupled oscillator so that it can be used as an effective c.w. monitor. A heavy, rigid cabinet and a large, vernier dial are necessary for accuracy when it is used as a frequency meter. The pin-jack at the upper right is wired to the output circuit of the oscillator and is used to connect an external "antenna" when sufficient pickup or radiation is not otherwise obtained.

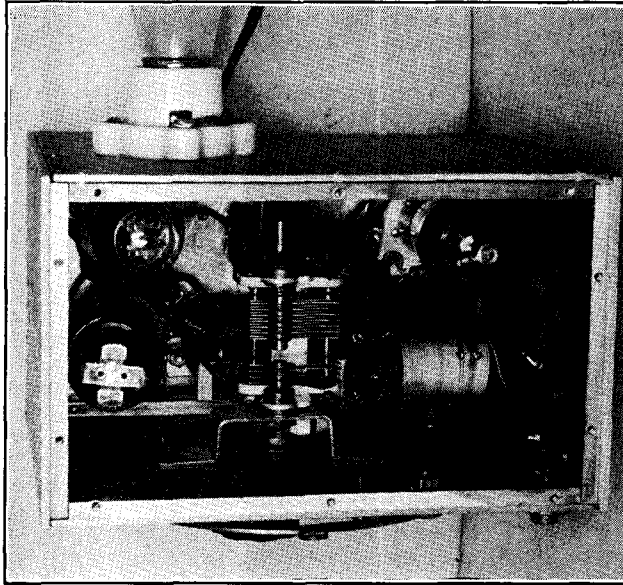

Figure 21.
INTERIOR VIEW OF THE
HETERODYNE FREQUENCY
METER.

A special bandspread condenser with lock nut on the bandset section is used. If desired, a line cord with built-in 320-ohm resistor, of the type used with a.c.-d.c. midgets, can be substituted for the Mazda lamp to drop the line voltage to a suitable value for the three series connected tube heaters.

The condenser used is one particularly designed for such use. It is in reality two condensers built in a single frame, each rotor being individually adjustable.

A good, finely-graduated vernier dial is essential for reading the setting of the smaller condenser for accurate determination of frequency. The instrument must be housed in a metal cabinet to prevent excessive pickup from the transmitter under test. The electron-coupled oscillator functions as a beat-note detector similar to the one in a short-wave regenerative receiver.

The metal cabinet in which the meter is housed *must* be rigid and well built. The one illustrated is of 1/8" sheet aluminum and measures 7" high x 8" long x 5" deep. It is held together by a generous number of angle brackets and screws.

Because only 90- or 100-volts plate supply is required for operation of the frequency meter, it is possible to dispense with a power transformer in the manner of the popular "a.c.-d.c." midgets. The three 0.3-ampere tube heaters and a 40-watt Mazda lamp are connected in series to work directly from

Figure 22.
WIRING DIAGRAM OF THE COMBINED FREQUENCY METER AND MONITOR.

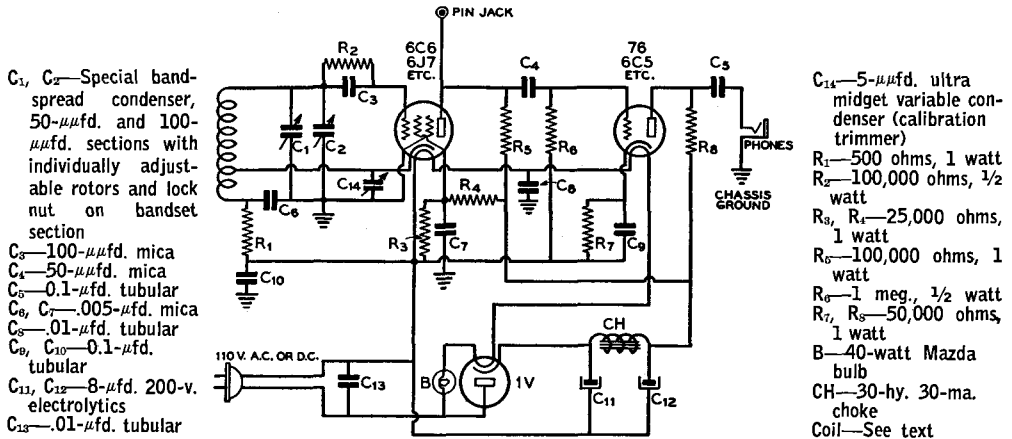

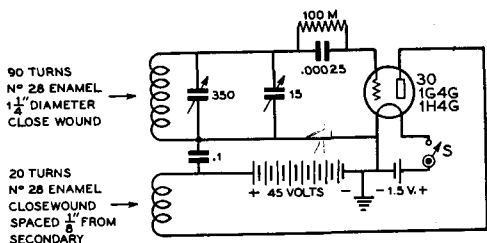

Figure 23.
BATTERY OPERATED CALIBRATION
OSCILLATOR.

This oscillator generates a very stable carrier over the broadcast range. Ticker polarity must be correct for oscillation.

either 110 volts a.c. or d.c. The lamp is mounted outside the cabinet to prevent heating of the components which would affect the calibration. The heat transmitted to the components inside the cabinet by the lamp is less than a power transformer mounted inside the cabinet would generate.

The oscillator coil consists of 37 turns of no. 22 d.c.e. spacewound on a 7/8"-diameter bakelite or ceramic form to cover 1 1/2" of winding space. It is tapped at the 9th turn (from the ground end) for the cathode connection. Duco cement should be applied to hold the turns firmly in place.

Calibration. The frequency meter may be calibrated in several ways. The simplest method is to calibrate it against signals of known frequency with the aid of a receiver. These signals can be tuned in on the short-wave receiver and the frequency meter tuned to the zero beat-note in the output of the radio receiver. External coupling can be provided from the frequency meter oscillator, if necessary for sufficient pickup, by connecting a short piece of wire to the pin-jack provided for the purpose on the front panel, and run-

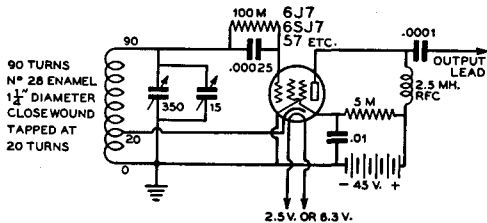

Figure 24.
CALIBRATION OSCILLATOR FOR A.C.
TUBES.

With heater type tubes, battery plate supply is still used with the calibration oscillator for reasons of stability.

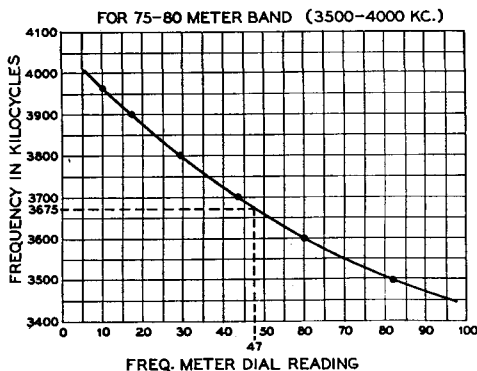

Figure 25.
TYPICAL FREQUENCY METER
CURVE.

For example—say freq. meter dial reading of signal was 47; project the vertical line "47" to calibration curve, then project this point horizontally to the kc. reading which, in this case, is 3675 kc.

ning it close to the receiver antenna lead-in in order to pick up r.f. energy from the frequency meter.

If a superheterodyne is used for calibration purposes, care must be taken that the frequency meter is *not tuned to the image frequency* of the radio receiver. A calibration chart can be plotted so that a frequency range of 3,500 to 4,000 kc. is obtained. Harmonics of the oscillator can be determined accurately by multiplying the frequency readings from the chart by the number of the harmonic.

A typical calibration chart is shown in figure 25. Here it is seen that the dial reading 60 indicates frequencies of 3600, 7200, 14,400 and 28,800 kc., the latter three being the second, fourth and eighth harmonics of the generated signal.

The device also can be used to measure frequencies in the 160 meter band, working on an "overtone." In this case the frequency as given on the calibration chart should be divided by 2 in order to ascertain the 160 meter band frequency.

The frequency meter can be calibrated by means of a calibration oscillator and a broadcast receiver. The calibration oscillator is tuned to zero beat in the broadcast receiver with carrier signals from broadcast stations of known frequency. The harmonics of the calibration oscillator are coupled into the frequency meter and the latter is tuned to zero beat, as heard through headphones in the output of the monitor. An example would be

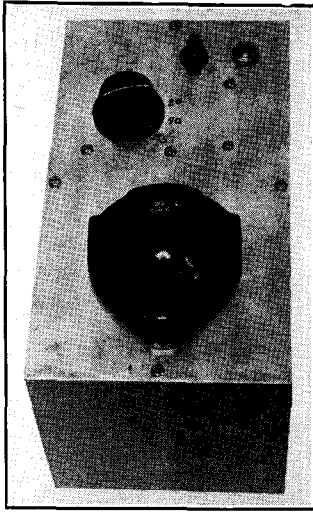

Figure 26.
BANDSWITCHING 20-40-80 METER
C.W. MONITOR.

This monitor is powered by self-contained batteries. Because the drain on the batteries is low, the cost of operation per hour is very slight.

where the local oscillator is tuned to zero beat with a broadcast station signal of 880 kc.; the fourth harmonic of the local oscillator would be four times 880 or 3520 kc. This value can be used to obtain a calibration point on the frequency meter. Zero-beating with broadcast stations is recommended as an accurate means of calibrating frequency meters and monitors, since these stations always operate well within the allowed frequency tolerance of plus or minus twenty cycles. Suggested circuits for calibration oscillators are shown in figures 23 and 24.

Before calibration is attempted, the band-setting condenser C_2 is adjusted so that the 75-85-meter band is "entered" on the dial. If the coil specifications are followed carefully, it will be possible to cover the 3500-4000-kc. range with a little overlap at either end. The lock nut on the bandset portion of the condenser should then be tightened to insure permanency of the adjustment. The shield cover (cabinet) should be bolted in place before calibration is attempted, as its presence has an appreciable effect upon the frequency.

The trimmer condenser C_4 is set so that the plates are about half meshed, and the instrument is allowed to warm up for several minutes. It is then ready to be calibrated.

When using the meter, first let it warm up a few minutes, then check one calibration

point on the calibration curve (preferably between 3700 and 3800 kc.). This can be done by means of the calibration oscillator working in conjunction with a broadcast receiver, or by checking the calibration against a crystal oscillator whose frequency is known exactly. It sometimes will be found that the calibration is off a small amount, due to temperature and other effects. When this is the case, the calibration can be restored by adjusting the trimmer C_4 until zero beat comes at the correct dial setting.

While this meter provides good accuracy, it should *not* be used as a means of placing your transmitter frequency right on the edge of a band.

Bandswitching C.W. Monitor

A c.w. monitor is a useful adjunct to a c.w. station as a means of checking the emitted signals for chirps, excessive ripple, key clicks, tails and other undesirable characteristics. A shielded monitor enables the operator to tell from within the station how the radiated signal sounds at a distance.

The c.w. monitor illustrated in figures 26 and 27 incorporates a battery-type dual triode, one-half of which acts as an oscillating detector and the other half as an audio amplifier. To make plug-in-coils unnecessary, band-switching is employed. Three coils and a selector switch allow choice of 20-, 40- or 80-meter operation at the flip of a switch.

A standard "Little Six" 1½-volt compact dry cell and a midget 45 volt B battery are used for power supply. The filament battery will give well over 100 hours operation before requiring replacement, and the plate battery will outlast several filament batteries. Both filament and plate batteries are enclosed in the cabinet, but are not fastened to the front panel as the other components are.

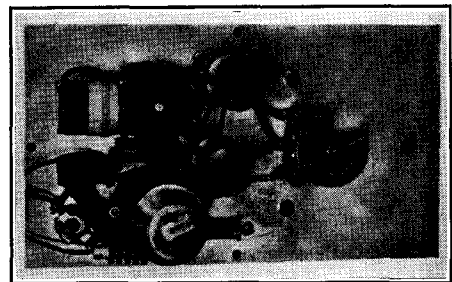

Figure 27.
BACK VIEW OF THE C.W. MONITOR.
All components except the batteries are supported
by the panel.

The shield can measures 5"x5"x9" and has just enough inherent leakage to allow pickup of a comfortable signal from a nearby transmitter. To prevent excessive pickup and blocking of the detector, the a.f. plate lead to the phones contains an r.f. choke to forestall pickup by way of the phone cords. If the transmitter is of low power, giving insufficient signal strength for monitoring purposes, the r.f. choke can be left out of the phone cord circuit. This will raise the signal strength noticeably.

All three coils are wound on 1½" lengths of 1-inch bakelite tubing as illustrated in figure 27. All windings are of no. 24 d.c.c. ex-

polarity of the tickler coils is correct, the detector will not oscillate.

General Purpose Phone Test Set

A phone test set is quite similar to a field-strength meter, yet it lends itself to making additional measurements. It can be used as an overmodulation indicator, phone monitor, field-strength meter, neutralizing indicator and wavemeter.

Such an instrument enables the operator to check for overmodulation of a phone transmitter. When the tuned circuit of the test set is coupled to the modulated amplifier or antenna system in such a manner as to obtain half-scale deflection of the milliammeter, any flicker of the meter reading will then be an indication of overmodulation. A change in meter reading during modulation is an indication of *carrier shift*; often this is a result of incorrect operating conditions, which may produce illegal interference in adjacent radiophone channels.

The phone test set consists of a diode rectifier connected across a tuned circuit, as shown in figure 31. A 0-1 d.c. milliammeter serves to check overmodulation, and is useful as an indicator in field-strength measure-

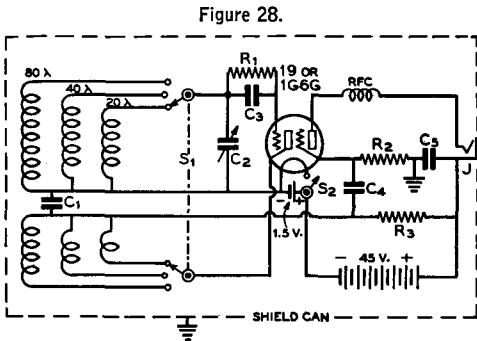

Figure 28.

WIRING DIAGRAM OF THE BANDSWITCHING C.W. MONITOR.

- | | |
|---|---|
| C ₁ —0.002-μfd. mica | watt |
| C ₂ —50-μμfd. midget variable | S ₁ —Two-pole three-position rotary switch |
| C ₃ —100-μμfd. mica | RFC—2½-mh. midget choke (omit if signal is not sufficiently strong with choke in circuit) |
| C ₄ , C ₅ —0.1-μfd. tubular | |
| R ₁ —0.5 meg., ½ watt | |
| R ₂ —1 meg., ½ watt | |
| R ₃ —20,000 ohms, ½ | |

cept the 80-meter grid coil, which is of no. 26 enamelled.

The 20-meter coil consists of 9 turns spaced ½" for the grid winding and 6 turns closewound for the tickler. The latter is wound at the ground end of the grid coil, with very little spacing between the windings.

The 40-meter coil consists of 22 turns spaced 1" for the grid winding and 7 turns closewound for the tickler which is wound at the ground end of the grid coil with very little spacing between the windings.

The 80-meter grid coil consists of 55 turns, closewound. The tickler is wound directly over the grid coil, near the grounded end of the latter, and is insulated from the grid winding by a layer of paper.

It should be borne in mind that unless the

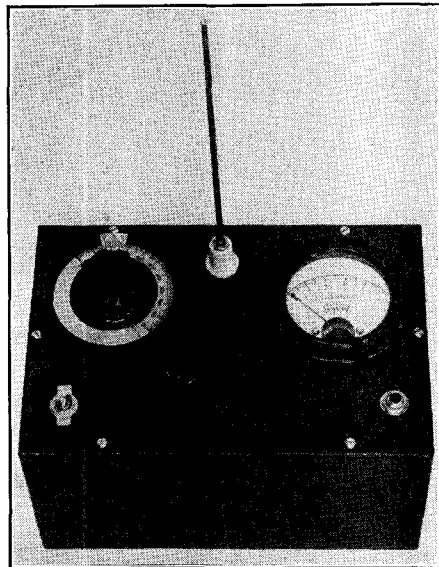

Figure 29. PHONE TEST SET.

This versatile instrument can be used as a phone monitor, an absorption wavemeter, field strength meter, overmodulation (carrier shift) indicator, or neutralizing indicator.

ments or neutralizing adjustments in a transmitter.

The audio volume with half to full scale meter indication is sufficient to give normal headphone response. A 5,000-ohm resistor is connected into the jack circuit for use when the test set functions as an overmodulation indicator. This resistor is in series with the diode and tends to produce a more linear rectification of the carrier wave.

For neutralizing or field-strength measurements, a short-circuiting plug or brass rod should be inserted into the phone jack to short-circuit the 5,000-ohm resistor and thereby increase the sensitivity of the meter. Neutralizing adjustments are made by coupling the test set's tuned circuit to the transmitter stage under test (without plate voltage applied to the stage). When the stage is completely neutralized, there will be either a minimum or zero deflection of the meter needle.

A short piece of brass rod, about 10 inches long, protrudes from the chassis as may be seen in figure 29; this rod acts as a pickup.

For most purposes the signal pickup with this rod will be sufficient, but when the instrument is used for measuring field strength and there is insufficient meter deflection for an accurate reading, an auxiliary antenna consisting of several feet of insulated wire may be coupled to the pickup rod by wrapping one end of the insulated wire around the pickup rod a few times. The small amount of capacity coupling provided will be sufficient to give a higher meter reading but will not be enough to disturb the frequency of the tank circuit appreciably.

When using the instrument in the neutralization of an r.f. amplifier, a short piece of flexible wire, about 18 inches long, is clipped directly to the pickup rod. The other end of the wire is brought closer and closer to the plate lead of the stage being neutralized until a substantial deflection is obtained.

Coil Data. The use of a 140- $\mu\mu\text{fd}$. tuning condenser permits use of one coil for 5 and 10 meters, another for 20 and 40 meters, and another for 80 and 160 meters.

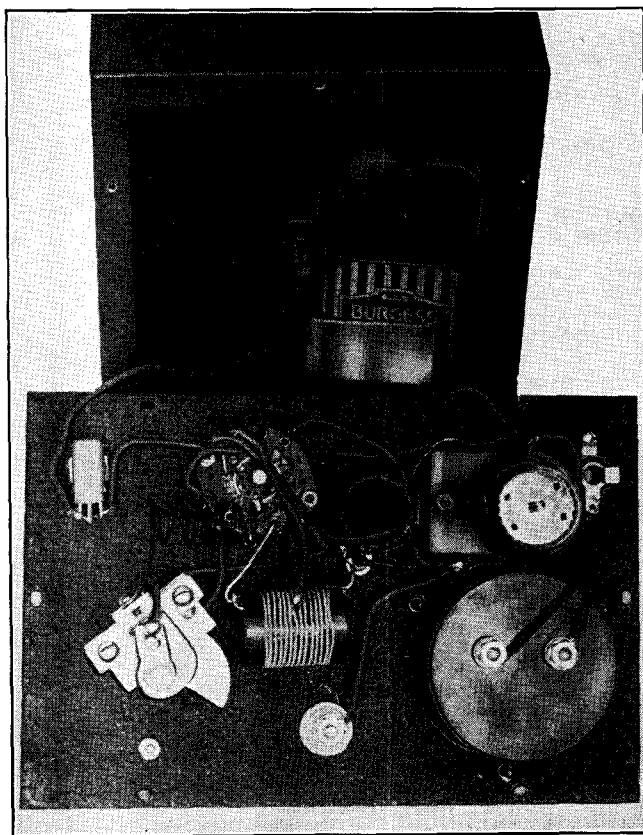

Figure 30.

INTERIOR CONSTRUCTION OF PHONE TEST SET.

All components of the general purpose phone test set are supported by the front panel; the single dry cell used for filament supply is strapped to the cabinet as illustrated.

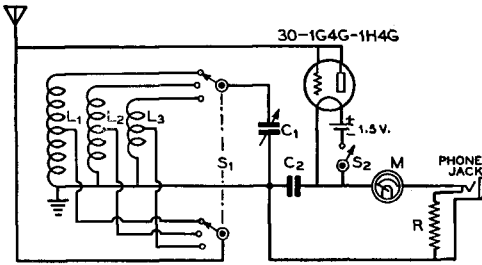

Figure 31.

WIRING DIAGRAM OF THE PHONE TEST SET.

- C₁—140- μ fd. midget
- C₂—.001- μ fd. mica
- L₁, L₂, L₃—See text
- R—5000 ohms, 1/2 watt
- S₁—Two-pole three-position rotary switch
- S₂—Toggle switch
- M—0-1 ma. d.c. 3" meter

For 5 and 10 meters the coil consists of 5 turns of no. 14 wire, 1/2" diameter and spaced to occupy a length of 1 inch. This coil is self-supporting and is soldered directly to the coil switch and tuning condenser rotor.

The 20-40-meter coil consists of 14 turns of no. 22 d.c.c. spaced to 1 inch on a 1 1/8"-diameter form.

The 80-160-meter coil has 55 turns of no. 26 enamelled, closewound on a 1 1/8"-diameter form.

Calibration. If the instrument illustrated is duplicated carefully, there will be no need for plotting a calibration curve or table for the individual meter in terms of decibels. The following table will be sufficiently accurate (arbitrary zero db reference level taken as .05 ma. deflection).

0.05 ma.—0 db	0.60 ma.—16 db
0.10 ma.—4 1/2 db	0.70 ma.—17 db
0.20 ma.—8 1/2 db	0.80 ma.—18 db
0.30 ma.—11 db	0.90 ma.—19 db
0.40 ma.—13 db	1.00 ma.—20 db
0.50 ma.—14 1/2 db	

An individual frequency calibration must be made to cover use of the instrument as an absorption wavemeter. As a wavemeter, the instrument should be used only for rough measurements, such as determining the order of a harmonic.

Keying Monitor and Code Practice Oscillator

The simple device illustrated in figure 32 has many uses. It may be used as a keying monitor, facilitating accurate sending of the code characters (especially useful with a "bug" key) and as a "watchdog" on the

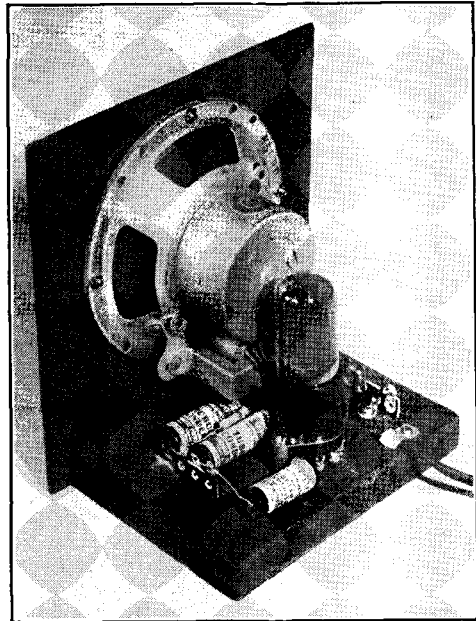

Figure 32.

KEYING MONITOR AND CODE PRACTICE OSCILLATOR.

This versatile unit may be used as a c.w. monitor, an audio "howler" for code practice, or as a test speaker requiring no field supply.

character of the note. Any ripple or keying chirp present in the carrier in sufficient degree as to be objectionable is readily apparent on the monitor. It also may be used as a code practice oscillator. The speaker itself, requiring no external field supply, will come in handy around the test bench for use as a test speaker. To give the device this wide utility, several connections are brought out to terminals.

The speaker is a 5 inch p.m. dynamic type complete with midget push pull output transformer. The output transformer acts as the oscillation transformer for the tetrode section of the 117L7GT, which is used as a conventional Hartley oscillator. For plate voltage, some r.f. carrier voltage is picked up from the final amplifier plate coil by a few turns of heavily insulated wire and fed to the monitor by means of a twisted pair or coaxial line. This carrier is rectified by the rectifier section of the 117L7GT and utilized as plate voltage. The plate by-pass condenser C₂ filters the rectified carrier into pure d.c. if the carrier itself is free from ripple. However, the time constant of this condenser is fast enough that any ripple in the carrier will show up as modulation of the signal gen-

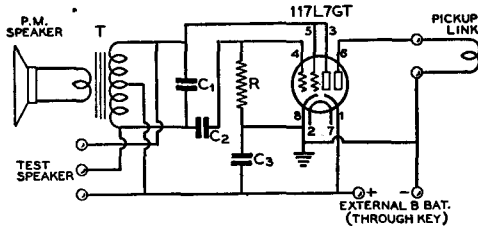

Figure 33.

WIRING DIAGRAM OF VERSATILE KEYING MONITOR.

The line voltage is applied directly to the heater of the 117L7GT, prongs 2 and 7 on the octal socket.

- T—Midget push-pull output transformer (on speaker)
- C₁—0.01- μ fd. (smaller capacity will give higher pitched note)
- C₂—0.05- μ fd. tubular
- C₃—0.1- μ fd. tubular
- R—25,000 ohms, 1/2 watt

erated by the keying monitor. Likewise any keying lag will be apparent, because the strength of the monitor signal is determined by the strength of the carrier.

The amount of r.f. picked up by the pickup coil is adjusted until the monitor signal is of the desired volume. The r.f. power required is quite small, less than a watt for full room volume. For keying monitor use the terminals marked "external B bat." should be shorted.

For use as a code practice oscillator, a small B or C battery is connected in series with a key and hooked to the terminals indicated. A 22½ volt battery will give good room volume, and a fair signal is obtained with as little as 4½ volts. The current drain is low and the battery will have long life.

The tone or pitch of the oscillator can be varied by changing the value of C₁. A smaller capacity will give a higher pitched note, and vice versa. If the condenser is made too large, however, the tube will no longer oscillate.

A "loose" speaker requiring no field supply is often useful for test purposes. By bringing out leads from the three primary wires to terminals as shown in the diagram, the speaker may be used for such purposes. For such work, the heater of the 117L7GT is not lit.

When used as a test speaker the highs will be somewhat attenuated in the manner of "tone control" because of the effect of the shunt condenser C₁. If suppression of the extremely high voice frequencies is undesirable, provision for opening one lead to C₁ can be made.

If the speaker transformer is of the variable ratio type, the voice coil tap should be

chosen to give 14,000 ohms across the full primary, though this adjustment is not especially critical. More volume can be obtained for a given plate voltage by adjusting the voice coil tap for a lower primary impedance, but if this is carried too far the tube will not oscillate at low plate voltage. To give a true replica of the monitored signal, the monitor should be capable of oscillating on as little as 3 volts.

The unit is constructed on a small wooden baseboard and a Masonite front panel. The unit may be enclosed in a small cabinet or wooden box if desired.

Volt-Ohmmeters

Perhaps the most useful single piece of test equipment is the *volt-ohmmeter*. The circuit of a typical volt-ohmmeter of the multiple range type is shown in figure 34. Tap 1 is used to permit use of the instrument as a 0-1 ma. milliammeter. Tap 2 permits accurate reading of resistors up to 100,000 ohms; Taps 3, 4, 5, and 6 are for making voltage measurements, the full scale voltages being 10, 50, 250, and 500 volts respectively.

The 1000-ohm potentiometer is used to bring the needle to zero ohms when the terminals are shorted; this adjustment should always be made before a resistance measurement is taken.

Higher voltages than 500 can be read if a higher value of multiplier resistor is added to an additional tap on the switch. The proper value for a given full scale reading can be determined from Ohm's law.

Resistances higher than 100,000 ohms cannot be measured accurately with the circuit constants shown; however, by increasing the

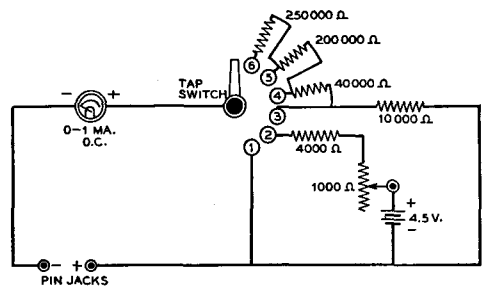

Figure 34.

VOLT-OHMMETER CIRCUIT.

- Position 1 of Switch 0-1 ma.
- Position 2 of Switch 0-100,000 ohms
- Position 3 of Switch 0-10 volts
- Position 4 of Switch 0-50 volts
- Position 5 of Switch 0-250 volts
- Position 6 of Switch 0-500 volts

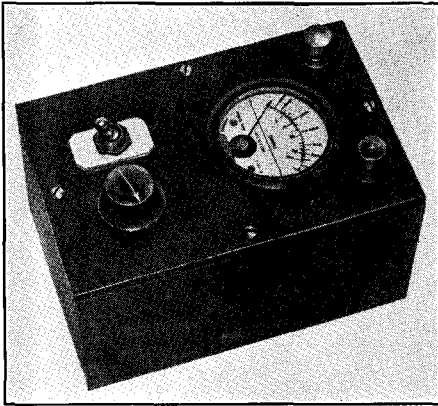

Figure 35.
LOW RANGE OHMMETER.

This ohmmeter is particularly useful for measuring resistances too low to be read accurately on an ohmmeter of the type illustrated in figure 34.

ohmmeter battery to 45 volts and multiplying the 4000-ohm resistor and 1000-ohm potentiometer by 10, the ohms scale also will be multiplied by 10. This would permit accurate measurements up to 1 megohm.

0-1 ma. meters are available with special volt-ohmmeter scales which make individual calibration unnecessary. Or, special scales can be purchased separately and substituted for the original scale on the milliammeter.

Obviously the accuracy of the instrument either as a voltmeter or as an ammeter can be no better than the accuracy of the milliammeter and the resistors.

Because volt-ohmmeters are so widely used and because the circuit is standardized to a considerable extent, it is possible to purchase a factory-built volt-ohmmeter for no more than the component parts would cost if purchased individually. For this reason no construction details are given. However, anyone already possessing a suitable milliammeter and desirous of incorporating it in a simple volt-ohmmeter should be able to build one from the schematic diagram and design data given here. Special, precision (accurately calibrated) multiplier resistors are available if extreme accuracy is desired.

Medium-and Low-Range Ohmmeter

Most ohmmeters, including the one just described, are not adapted for accurate measurement of low resistances—in the neighborhood of 100 ohms, for instance.

The ohmmeter illustrated in figure 35 was especially designed for the reasonably ac-

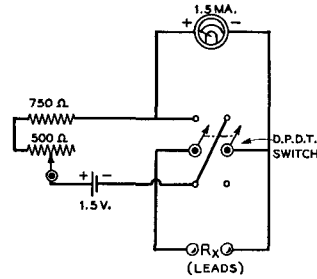

Figure 36.
Diagram of the low-range ohmmeter illustrated in figure 35.

curate reading of resistances all the way down to one ohm. Two scales are provided, one going in one direction and the other scale going in the other direction because of the different manner in which the milliammeter is used in each case. The low scale covers from 1 to 100 ohms and the high scale from 100 ohms to 10,000 ohms. The high scale is in reality a medium-range scale. For accurate reading of resistances over 10,000 ohms, an ohmmeter of the type previously described should be used.

The 1-100 ohm scale is useful for checking transformers, chokes, r.f. coils, etc., which often have a resistance of only a few ohms.

The calibration scale will depend upon the internal resistance of the particular make of 1.5-ma. meter used. The instrument can be calibrated by means of a Wheatstone bridge or a few resistors of known accuracy. The latter can be series-connected and parallel-connected to give sufficient calibration points. A hand-drawn scale can be pasted over the regular meter scale to give a direct reading in ohms.

Before calibrating the instrument or using it for measurement, the test prods should always be touched together and the zero adjuster set accurately.

A.F. and R.F. Power Measuring Device

For accurate measurement of a.f. and r.f. power a thermogalvanometer in series with a non-inductive resistor of known resistance can be used. The meter should have good accuracy, and the exact value of resistance should be known with accuracy. Suitable dummy load resistors of the "vacuum" type are available in various resistances in both 100 and 250 watt ratings. These are virtually non-inductive and may be considered as a pure resistance except at ultra high frequencies.

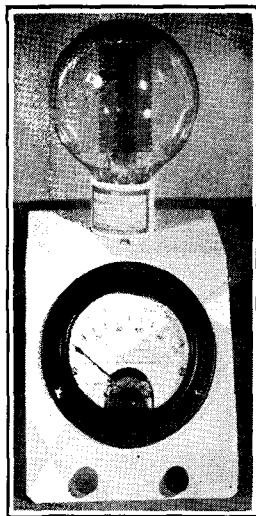

Figure 37.
R.F. AND A.F. POWER
MEASURING DEVICE.

A thermogalvanometer or thermoammeter is placed in series with a non-inductive dummy load resistor whose resistance is known accurately.

The resistance of these units is substantially constant for all values of current up to the maximum dissipation rating, but where extreme accuracy is required a correction chart of the dissipation coefficient of resistance (supplied by the manufacturer) may be employed. This chart shows the exact resistance for different values of current through the resistor.

If a current-squared r.f. galvanometer (commonly 115 ma. full scale deflection reading 0-100) is used, it will be necessary to use a conversion chart to determine the exact value of current from the scale reading. If a thermo ammeter is used, the current reading can be taken directly from the meter.

Bandswitching Signal Generator

A modulated test signal is required for lining up a superheterodyne receiver in order to simplify the procedure. The intermediate and tuned-radio-frequency circuits in the receiver must be properly aligned; a signal generator produces a signal similar to that of a weak radio signal, yet it is instantly available at any desired frequency.

The simple, one-tube modulated oscillator illustrated in figures 38 and 39 and diagrammed in figure 40 covers the range of 75 to 1500 kc. by means of bandswitching. Its harmonics can be used for work at still higher frequencies.

The oscillator circuit is a standard *Hartley*. A variable grid leak is controlled from the front panel; this gives a means for obtaining either unmodulated or self-modulated car-

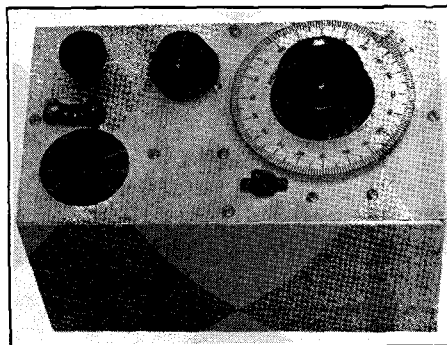

Figure 38.
TEST SIGNAL GENERATOR.

This test signal generator covers the range of from 75 kc. to 1500 kc. by means of bandswitching. It is important that the instrument be built in a metal can which shields it thoroughly.

rier signals. High values of grid leak cause a blocking grid action, and the result is a test r.f. signal modulated at an audio frequency of 500 to 1,000 cycles. This grid leak resistor at low resistance values produces an unmodulated signal which simulates that of a c.w. signal.

A signal 1.5-volt dry cell and a 22.5-v. C-battery furnish filament and plate potentials for the oscillator. The entire instrument, including the batteries, is contained in a metal can measuring 5"x5"x9". Any 350- or 375- $\mu\text{mfd.}$ b.c.l. type variable condenser and dial may be used. The one used in the model illustrated is an old Remler b.e. condenser.

Level Control. A small portion of the r.f. voltage across the plate side of the tuned circuit is applied across a condenser type voltage divider consisting of a 3-30- $\mu\text{mfd.}$ mica trimmer and a .0005- $\mu\text{mfd.}$ fixed mica condenser. The trimmer is set near maximum capacity to give the optimum capacity ratio, a compromise between stability and maximum available output signal voltage. A 200-ohm potentiometer is used as an attenuator to regulate the amplitude of the test signal. Variation in output level is obtained by this method without appreciably affecting the frequency of the oscillator. However, this reduces the amplitude of the maximum test signal voltage available.

The modulated wave emitted by the oscillator is rather broad but is suitable for most receiver alignment work.

Coil Data. All three coils are jumble-wound on $\frac{1}{2}$ " diameter porcelain insulator rods or wooden dowels, and are center-

Figure 39.
**INTERIOR OF THE BATTERY
 POWERED TEST SIGNAL
 GENERATOR.**

Either a pure unmodulated or a modulated carrier wave can be obtained from the instrument. A continuously variable attenuator is provided for adjusting the output signal voltage to the desired level.

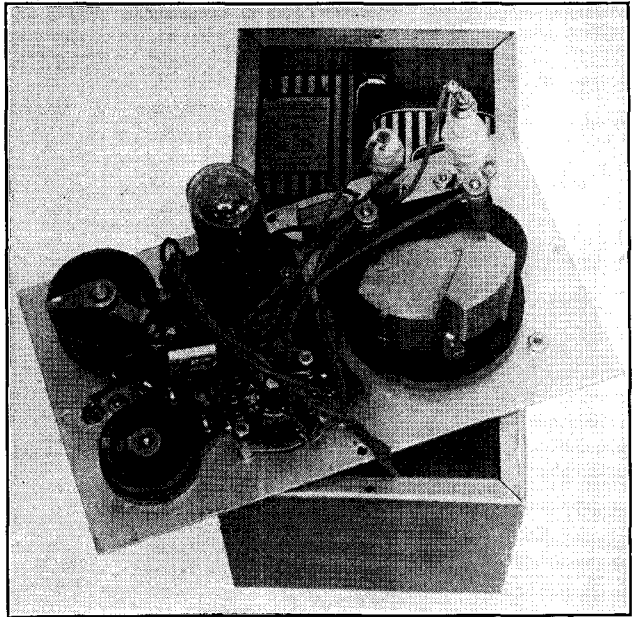

tapped. The number of turns for the various frequency ranges follow:

- 75-220 kc.—1100 turns no. 34 d.s.c. about $\frac{3}{4}$ " long.
- 200-500 kc.—450 turns no. 32 d.s.c. about $\frac{1}{2}$ " long.
- 500-1500 kc.—175 turns no. 26 d.c.c. about $\frac{1}{2}$ " long.

Calibration. The instrument is calibrated by coupling it into a radio receiver which can be tuned to broadcast stations in the fre-

quency range of from 550 to 1500 kc. The oscillator is tuned to zero beat with broadcast station signals of a known frequency.

The range of from 200 to 500 kc. can be calibrated in a similar manner by using the harmonics of the signal generator to produce zero beat.

Wide Range Audio Oscillator

For testing audio amplifiers and modulators, a source of variable frequency audio frequency power having negligible harmonic content is of great usefulness. Such an oscillator is shown in figures 41-44. It covers from 70 to over 20,000 cycles, over which range the output remains substantially constant except at the low frequency end of the range.

The unit is built upon a standard chassis and panel and is placed into a standard cabinet. Note carefully that the rotor and frame of the tuning condenser are above ground potential and connected directly to the grid of the first amplifier stage. Consequently it was found necessary to isolate the power supply components physically from this condenser, to saw the rotor shaft short and use an insulated bakelite coupling to a metal dial, and to insulate the frame of the condenser from the chassis by small ceramic pillar insulators.

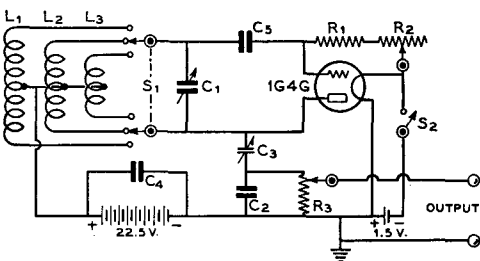

Figure 40.
**WIRING DIAGRAM OF THE TEST SIGNAL
 GENERATOR.**

- | | |
|--|--|
| C ₁ —0.0035 or .00037-
μfd. b.c. type con-
denser | C ₆ —0.02-μfd. mica |
| C ₂ —0.005-μfd. mica | R ₁ —5000 ohms, 1
watt |
| C ₃ —3-30 μμfd. mica
trimmer | R ₂ —5 meg. pot. |
| C ₄ —0.1-μfd. tubular | R ₃ —200-ohm pot. |
| | L ₁ , L ₂ , L ₃ —Refer to
text |

Aside from these precautions, and the one that the unit must be operated in its shielding box when in the vicinity of a high-power transmitter, the construction of the unit is quite conventional. It should be mentioned, however, that the exact components shown (especially resistor values) be used in the construction of the unit. The values shown are the result of considerable experimentation and variations greater than the normal tolerances of good-grade components are likely to disturb the balance between regenerative and degenerative feedback.

The waveform should be checked on an oscilloscope to see if it is a pure sine wave. If the tubes are normal, the resistors are not too far off, and the unit has been constructed and wired carefully, the waveform should be so perfect that it is impossible to detect any irregularities due to harmonic content.

Then check the wave form and output over the whole condenser dial and on all switch positions. The waveform should be perfect from about 100 cycles out to the upper frequency limit of the unit.

If the oscillations are too intense and the

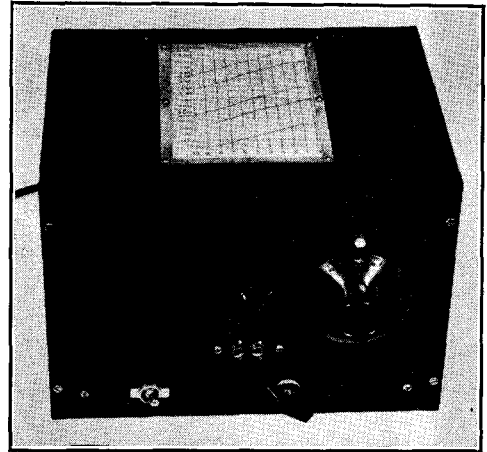

Figure 41.

WIDE RANGE AUDIO OSCILLATOR.

This unit delivers a.f. power from 75 to over 20,000 cycles, practically a pure sine wave at all frequencies above 100 cycles. It utilizes degenerative feedback to minimize distortion and output level variations.

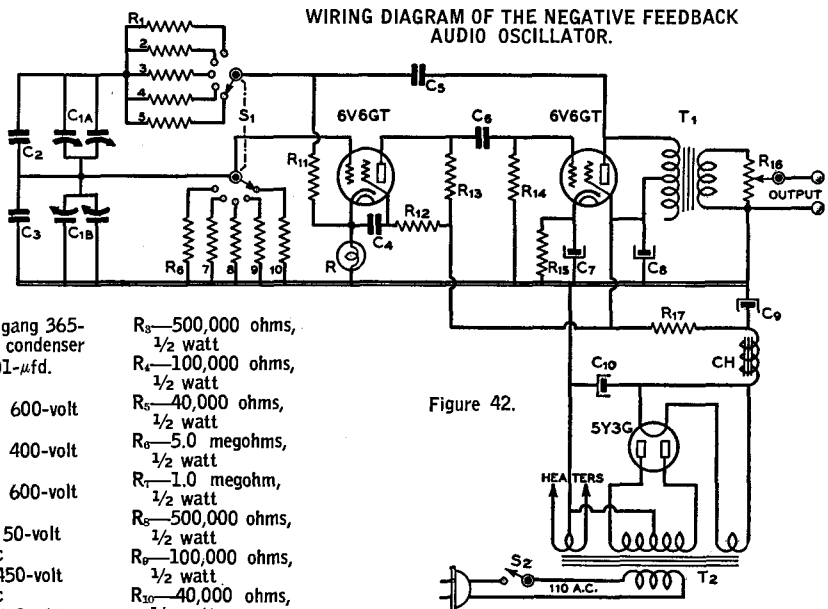

Figure 42.

- C_{1A}, C_{1B}—4-gang 365- μ fd. b.c. condenser
- C₂, C₃—0.001- μ fd. mica
- C₄—25- μ fd. 600-volt tubular
- C₅—0.5- μ fd. 400-volt tubular
- C₆—0.1- μ fd. 600-volt tubular
- C₇—10- μ fd. 50-volt electrolytic
- C₈—8- μ fd. 450-volt electrolytic
- C₉, C₁₀—Dual 8- μ fd. 450-volt electrolytic
- R—6-watt 120-volt tungsten lamp, Mazda S6
- R₁—5.0 megohms, 1/2 watt
- R₂—1.0 megohm, 1/2 watt
- R₃—500,000 ohms, 1/2 watt
- R₄—100,000 ohms, 1/2 watt
- R₅—40,000 ohms, 1/2 watt
- R₆—5.0 megohms, 1/2 watt
- R₇—1.0 megohm, 1/2 watt
- R₈—500,000 ohms, 1/2 watt
- R₉—100,000 ohms, 1/2 watt
- R₁₀—40,000 ohms, 1/2 watt
- R₁₁—2500 ohms, 1 watt
- R₁₂—10,000 ohms, 1 1/2 watts
- R₁₃—5000 ohms, 10 watts
- R₁₄—100,000 ohms, 1/2 watt
- R₁₅—400 ohms, 10 watts

- R₁₆—1000-ohm potentiometer (volume control)
- R₁₇—2000 ohms, 10 watts
- S₁—2-pole 6-position switch (only 5 positions used)

- S₂—A.c. line switch
- T₁—Universal output to voice coil transformer, Thordarson T-57501
- T₂—580 c.t., 50 ma.; 5 v., 3 a.; 6.3 v., 2 a.
- CH—10-hy. 65-ma. filter choke

Figure 43.
SHOWING CONSTRUCTION
OF THE WIDE RANGE AUDIO
OSCILLATOR.

The four gang b.c. condenser must be insulated from the chassis. It is driven by means of an insulated shaft extension.

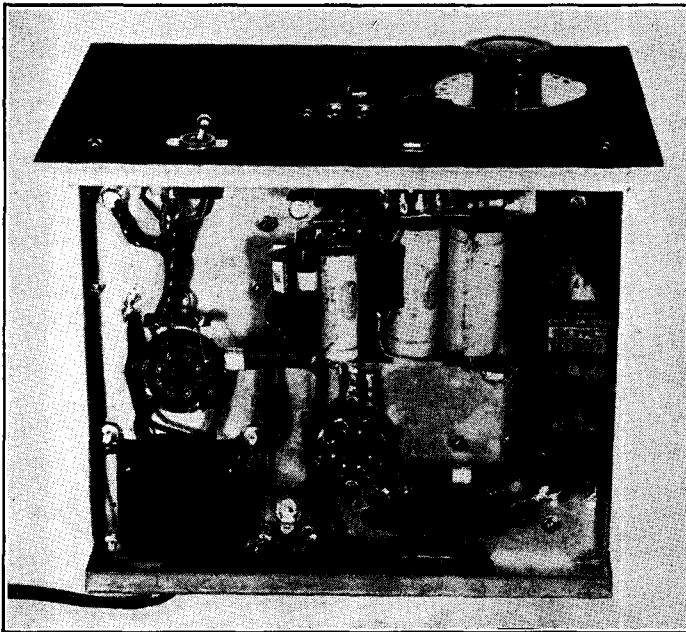
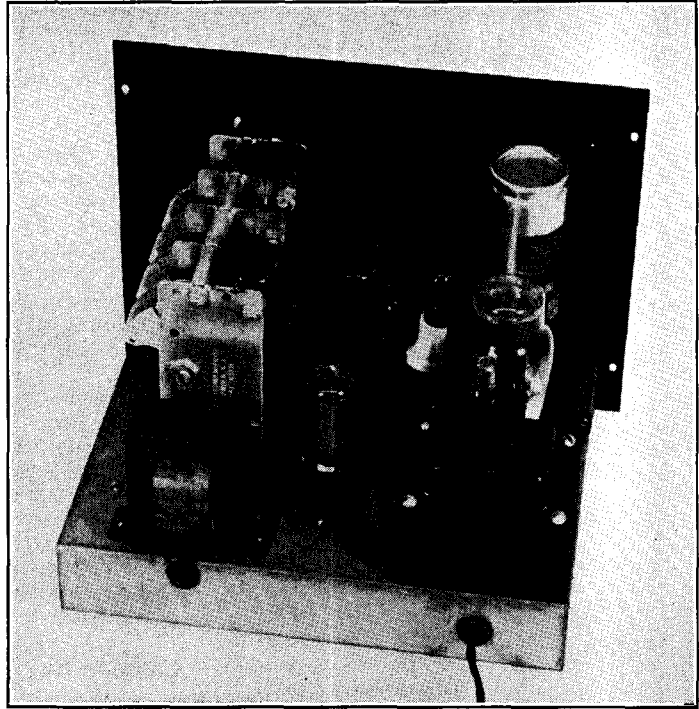

Figure 44.
UNDER-CHASSIS VIEW OF
THE A. F. OSCILLATOR.

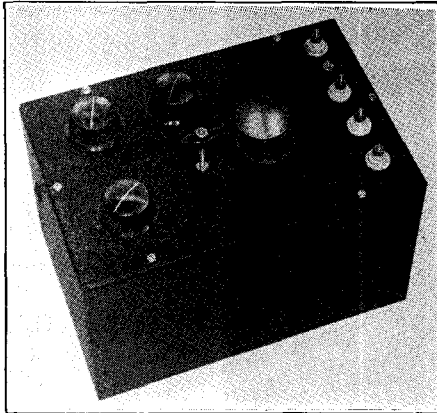

Figure 45.

CATHODE RAY MODULATION CHECKER.

This inexpensive oscilloscope is useful for obtaining trapezoidal modulation patterns. A cheap magnifying glass and tubular shade to keep out external light give a pattern comparable to that obtained with a 2-inch c.r. tube.

waveform is distorted, it will be necessary to decrease the resistance of R_{11} . This will increase the amount of degenerative feedback and reduce the oscillation amplitude. Conversely, if the amplitude is too low or if the unit quits oscillating at some point on some range, the value of the degeneration resistor R_{11} should be increased. If the values shown in the wiring diagram have been followed carefully the unit should operate properly immediately but if it does not it should only be necessary to make a slight change in the value of R_{11} to correct the difficulty.

Calibration. The approximate frequency ranges covered by the various taps are as follows: 75—220 cycles; 220—900 cycles; 450—2000 cycles; 2000—9000 cycles; and 4500—12,500 cycles.

The most satisfactory and least difficult method of calibration would be to check the unit by the zero-beat method against another audio oscillator which was already accurately calibrated. The unit also can be calibrated by means of an oscilloscope (one having a linear sweep) by utilizing the power line frequency as a base from which to start. This method of calibration requires that the operator be familiar with the interpretation of Lissajou's figures.

A piano or electric organ also can be used, because while it is easy to make an error of exactly one octave in a listening test when one or both tones are not pure sine waves, an error of a full octave would be quite obvious when the approximate frequency coverage (within a few percent) is known for each range of the instrument. This assumes that the instrument is an exact duplicate of the one illustrated in so far as circuit constants go.

Cathode-Ray Oscilloscopes

Measurements of r.f. and a.f. voltage and wave form can easily be made with the aid of a cathode-ray oscilloscope. Such a device includes a vacuum tube which has two sets of deflecting plates for controlling a beam of electrons; this beam strikes a fluorescent screen on the face of the tube and traces a pattern of the signal applied to the control grid or deflection plates. The fluorescent screen in the tube produces a visual indication

Figure 46.
WIRING DIAGRAM OF THE CATHODE RAY MODULATION CHECKER.

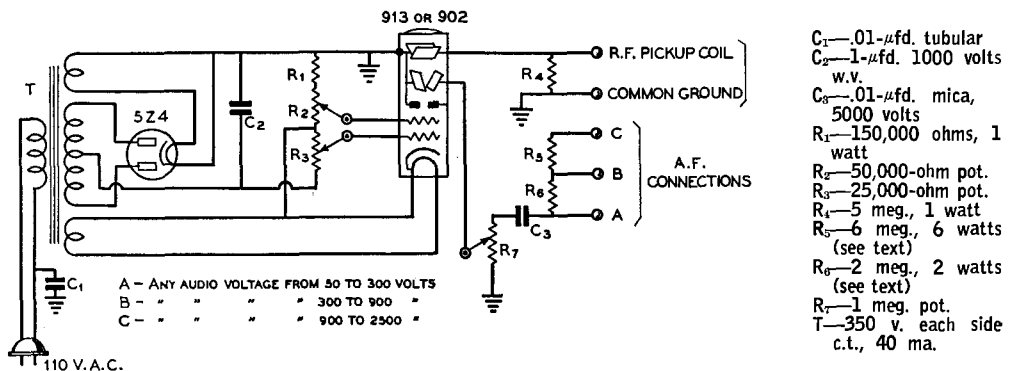

of the pattern of r.f. or audio voltages.
 Some of the many uses of the cathode ray oscilloscope in its various forms are as follows:
 Measurement of d.c. voltage or current.
 Measurement of peak a.c. and r.f. voltage.
 Trouble-shooting in receivers.
 Adjustment of i.f. stages (including band-pass).
 Measurement of audio amplifier distortion, overload and gain.
 Adjustment phase-inversion circuits.

Checking of power supplies.
 Checking of harmonic content.
 Measurement of phase angle and phase distortion.
 Measurements for dynamic tube characteristic curves.
 Checking of phone signals and per cent modulation by:
 Modulation envelope
 Trapezoidal pattern
 Cat's eye pattern
 Making condenser power factor tests.

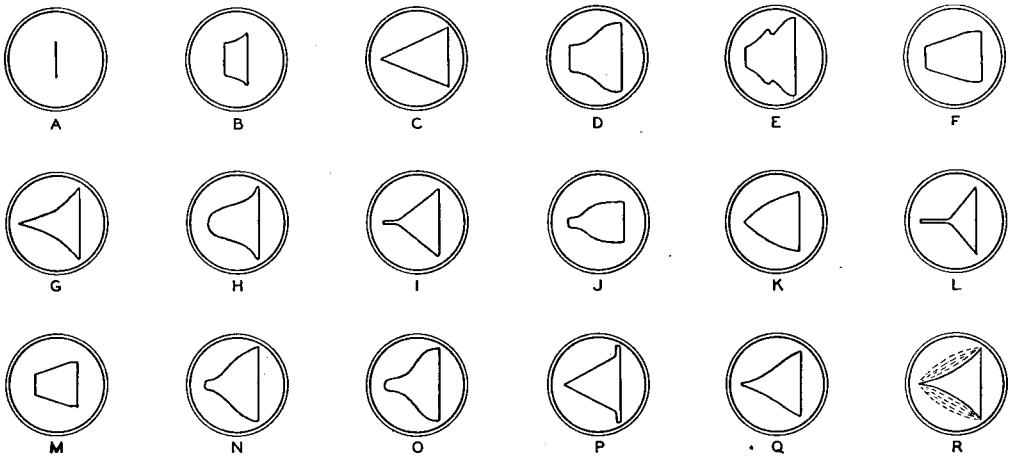

Figure 47.
 TYPICAL OSCILLOGRAPHIC MODULATION PATTERNS.

It is assumed that there is negligible distortion in the a.f. voltage fed to the horizontal deflecting plates. (This voltage usually is taken from the last stage in the speech amplifier.) Also, except in the case of figure R, it is assumed that there is negligible phase shift between the a.f. voltage applied to the horizontal deflecting plates and the a.f. voltage modulating the r.f. amplifier. Often an imperfect trapezoid at 100% modulation is a result of several factors, making it difficult to interpret the pattern and diagnose the trouble.

- A: Unmodulated carrier signal.
- B: Undistorted plate, grid, or cathode modulation, less than 100%.
- C: Undistorted 100% plate modulation.
- D: Plate modulation with inadequate or mismatched modulator.
- E: Same as D with regeneration in modulated stage.
- F: Plate modulated, insufficient grid excitation and/or bias to allow over 50% undistorted modulation. Grid modulated, too much excitation to allow over 50% modulation in upward direction.
- G: Plate modulated, imperfect neutralization permitting regeneration.
- H: Grid modulated phone with improper neutralization and reactive load.
- I: Overmodulation of well designed, plate modulated transmitter. Too much audio input.
- J: Grid modulation, excessive excitation or poor regulation of r.f. driver.
- K: Insufficient excitation and bias on plate modulated zero bias (very high μ) triode.
- L: Very bad overmodulation of plate modulated transmitter, resulting in serious clipping of negative peaks and bad splatter.
- M: Maximum plate modulation of screen grid tube without screen modulation (screen bypassed for a.f.).
- N: Suppressor modulated phone using separate r.f. driver, modulated approximately 100%.
- O: Suppressor modulated 802 or 804 with crystal in grid circuit.
- P: Parasitics in modulated amplifier, not present except on positive modulation peaks.
- Q: Grid or cathode modulation, properly adjusted, approximately 100% modulation. Very little distortion.
- R: Phase shift in speech system between point at which voltage is taken for horizontal deflection and the modulator output. No distortion.

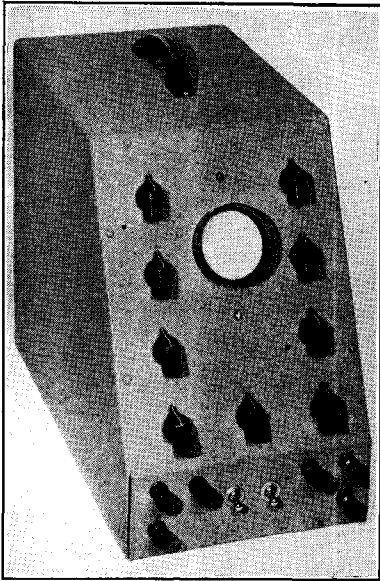

Figure 48.
DE LUXE CATHODE RAY
OSCILLOSCOPE.

With amplifiers and linear sweep, this oscilloscope can be built at a reasonable price yet will do most anything a larger model will do. The cathode ray tube is a 2 inch RCA-902.

Making overall frequency response tests.
Determining unknown frequencies.
Adjusting auto vibrators.
Studying surges and transients.

Cathode-ray oscilloscopes are extremely useful for measuring percentage modulation and analyzing distortion in a radiophone transmitter.

While constructional data is given for two oscilloscopes, one a simple instrument for checking modulation in a radiophone transmitter and the other a more elaborate instrument possessing greater versatility, anyone contemplating construction of an oscilloscope should invest in one of the many excellent books on the subject, available very reasonably from *Rider, RCA Manufacturing Co., Dumont* and others. Because of space limitation, a comprehensive treatise on the theory, construction and use of oscilloscopes is not within the scope of this book. This will be appreciated when it is realized that there appear books on oscilloscopes which contain over 100 pages devoted to applications of the instrument alone.

The accelerating anode potentials used in many oscilloscopes, particularly the larger sizes, are high enough to be very dangerous.

C. R. Modulation Checker

A very simple oscilloscope, such as the one shown in figures 45 and 46, is entirely satisfactory for modulation checking. It consists of an RCA-913 cathode-ray tube which has a fluorescent screen approximately one inch in diameter. This tube, and a suitable power supply, are built into a small metal cabinet measuring 5"x6"x9".

A dime magnifying glass obtainable at any five-and-ten-cent store gives a trapezoidal figure comparable in size to that of a 2" cathode-ray tube. The magnifying glass is held about 2 inches from the screen of the 913 by a piece of bakelite tubing which is slipped over the 913 and allowed to project slightly beyond the magnifying glass in order to keep out external light. If desired, a 902 (two inch screen) may be substituted for the 913; no circuit changes will be required.

Three a.f. binding posts allow connection of the scope to the modulator of any phone transmitter with 5-to 1000-watts carrier power. No external coupling condenser is required; a lead may be connected directly to the class C amplifier plate return circuit at the modulation transformer terminals. *Beware of the high voltage.* Connections for a grid-modulated transmitter are similar, except that the modulation transformer connection is in the grid-return instead of the plate return circuit of the r.f. amplifier. The resistor network adapts the instrument for use on any transmitter at a moment's notice; no trouble will be experienced in getting just the right amount of audio deflecting voltage.

The network resistors R_1 and R_2 are not standard items; each is made up of 1-megohm 1-watt carbon resistors in series, R_1 requiring six such resistors and R_2 two. The 1-watt resistors are mounted on terminal strips.

When a voltage is applied to only one set of plates, a thin straight line is obtained on the face of the cathode-ray tube when the 25,000- and 50,000-ohm potentiometers are correctly adjusted.

When a modulated carrier voltage is applied to one set of plates, and the audio modulating voltage applied to the other, a *trapezoidal figure* will be produced during modulation. With 100 per cent modulation this pattern should be a straight-sided triangle, sharply pointed. Typical patterns are shown for plate and grid modulation in the accompanying sketches, figure 47.

The audio- or radio-frequency voltage should have an amplitude of at least 50 volts in order to cause good deflection on the screen. The amplitude should be sufficient to give a

Figure 49.
VERSATILE CATHODE RAY OSCILLOSCOPE INCORPORATION DEFLECTION PLATE AMPLIFIERS, LINEAR SWEEP, AND RCA-902 TWO INCH C.R. TUBE.

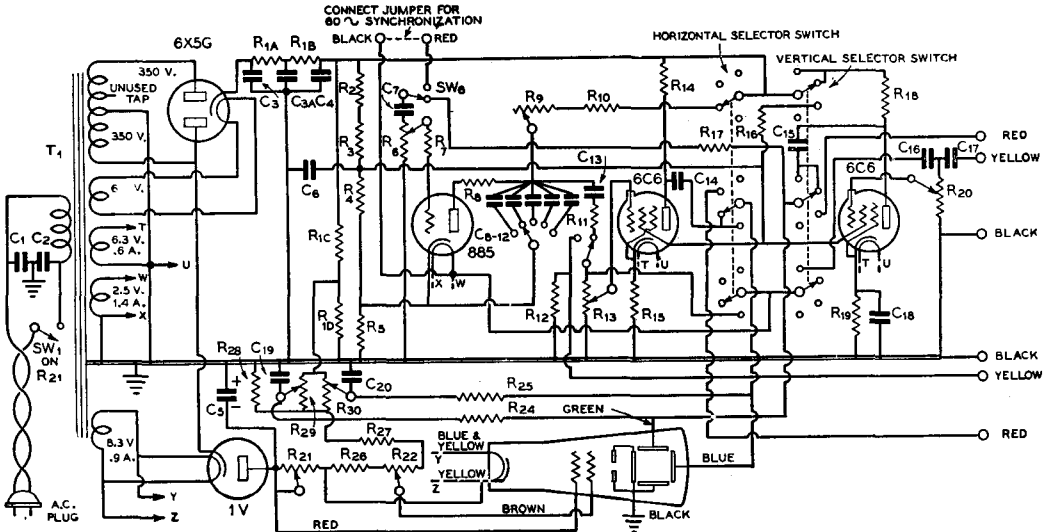

- R₁—5000 ohms, 1 watt
- R_{1A}, R_{1B}—2500 ohms, 1 watt
- R_{1C}—250,000 ohms, 1 watt
- R_{1D}—50,000 ohms, 1/2 watt
- R₂, R₃, R₄—40,000 ohms, 1 watt
- R₅—1500 ohms, 1/2 watt
- R₆—50,000-ohm potentiometer
- R₇—25,000 ohms, 1/2 watt
- R₈—200 ohms, 1/2 watt
- R₉—5-megohm potentiometer
- R₁₀—750,000 ohms, 1/2 watt
- R₁₁, R₁₂—1 megohm, 1/2 watt
- R₁₃—3-megohm potentiometer

- R₁₄—100,000 ohms, 1 watt
- R₁₅—1000 ohms, 1/2 watt
- R₁₆—200,000 ohms, 1 watt
- R₁₇—2 megohms, 1/2 watt
- R₁₈—100,000 ohms, 1 watt
- R₁₉—1000 ohms, 1/2 watt
- R₂₀—500,000-ohm potentiometer
- R₂₁—25,000-ohm potentiometer with a.c. line switch
- R₂₂—50,000 ohm pot.
- R₂₃—150,000 ohms, 1 watt
- R₂₄—2 megohms, 1/2 watt
- R₂₅—4 megohms, 1/2 watt
- R₂₆—25,000 ohms, 1/2 watt

- R₂₇—100,000 ohms, 1 watt
- R₂₈—100,000 ohms, 1 watt
- R₂₉, R₃₀—100,000-ohm potentiometers
- C₁, C₂—0.1- μ fd. 400-volt tubular
- C₃, C₄, C₅—8- μ fd. 450-volt electrolytics
- C_{6A}—8- μ fd. 450-volt electrolytic
- C₆—2- μ fd. 200-volt electrolytic
- C₇—0.1- μ fd. 400-volt tubular
- C₈—0.5- μ fd. 400-volt tubular
- C₉—0.1- μ fd. 400-volt tubular
- C₁₀—0.2- μ fd. 400-volt tubular
- C₁₁—0.05- μ fd. mica
- C₁₂—0.001- μ fd. mica
- C₁₃, C₁₄, C₁₅, C₁₆, C₁₇—0.1- μ fd. 400-volt tubular

- C₁₈—0.5- μ fd. 400-volt tubular
 - C₁₉, C₂₀—0.1- μ fd. 400-volt tubular
 - T₁—Cathode ray oscilloscope transformer
 - SW₁—Line switch on R₂₁
 - SW₂—5-position single-pole switch
 - SW₃—D.p.d.t. toggle switch
 - SW₄, SW₅—3-circuit 4-position, non-shorting switch
 - SW₆—S.p.d.t. toggle switch
 - C.r. tube—RCA-902
 - C.r. tube mounting—Amphenol 913 plug and bracket assembly.
- Note: Either 6C6's or 6J7's may be used with equally good results, the 6J7's requiring less space.

large pattern on the face of the tube. The 25,000- and 50,000-ohm potentiometers are adjusted to give sharp definition and a reasonable amount of illumination on the screen. The r.f. voltage can be secured by coupling a few turns of wire to the center of the modulated amplifier tank coil or to the antenna coupler.

The tube should not be allowed to run for more than an instant with no deflecting voltages applied, as a burned spot will appear on

the screen of the tube if the electron stream is allowed to converge for long on a single small spot.

C.R. 'Scope with Sweep Circuit

Most audio-frequency measurements require a variable frequency sweep oscillator circuit which can be synchronized with the frequency of the audio voltage being tested. For this purpose, a saw-tooth wave form is

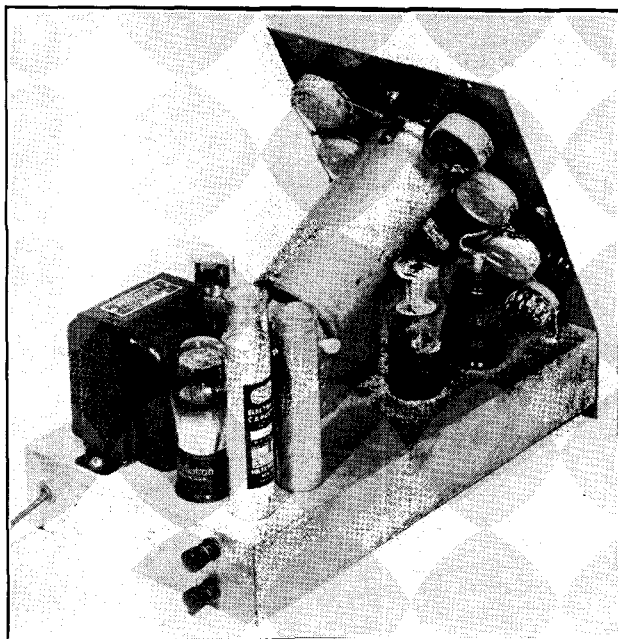

Figure 50.
 INTERIOR CONSTRUCTION OF
 THE C.R. OSCILLOSCOPE.

The piece of heavy iron pipe shields the cathode ray tube both inductively and electrostatically. The pipe is supported from the panel by angle brackets. Sufficient space should be allowed to rotate the power transformer to eliminate any inductive coupling remaining after the pipe shield has been installed.

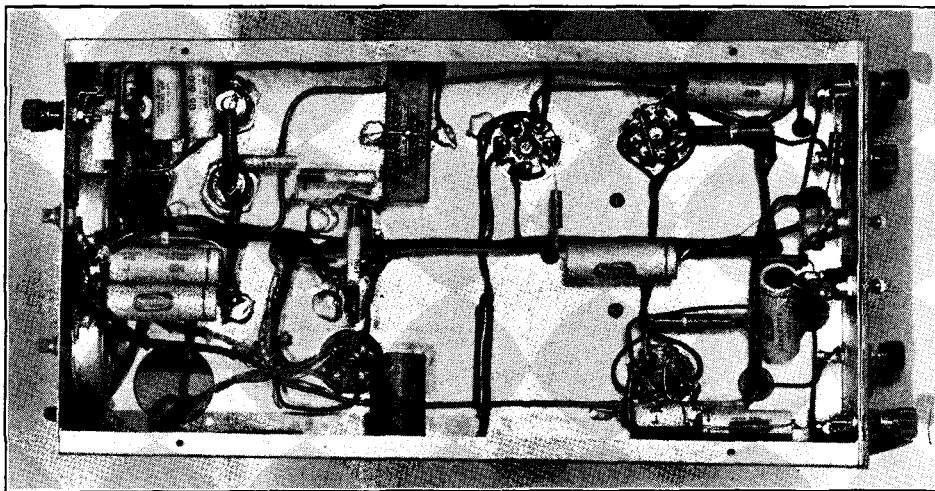

Figure 51.

SHOWING LAYOUT OF COMPONENTS MOUNTED BELOW THE CHASSIS.

The leads going to the various selector switches and potentiometers should not be cabled, though the heater and power supply leads may be cabled without harm.

desirable; it can be obtained from a condenser-charge-and-discharge-circuit. The condenser is slowly charged, then rapidly discharged by means of a gas-filled type 885 triode which ionizes at a certain peak voltage and short-circuits the condenser in the plate circuit.

The sweep circuit oscillation can be synchronized with that of the audio-frequency signal by applying a small portion of the latter to the grid circuit of the type 885 tube. The approximate frequency of the saw-tooth oscillator is adjusted by means of the capacity in the plate circuit of the tube and the value of the resistance in series with the B-plus lead from this tube. The output of this oscillator must be amplified by a high-gain audio stage in order to provide sufficient voltage to produce a sweep across the screen of the cathode-ray tube.

The oscilloscope diagrammed in figure 49 contains vertical and horizontal deflection plate amplifiers, linear sweep and most of the adjuncts found in the most expensive oscilloscopes. The only difference is the use of a small 902 two-inch c.r. tube for the sake of economy.

In order to minimize both the inductive and electrostatic pickup of a.c. ripple by the c.r. tube, the tube is shielded by placing it inside a piece of galvanized iron pipe just sufficiently large to take the tube, and the power transformer is rotated slightly until the sharpest line is obtained. The method of housing the tube in the piece of iron pipe may be seen in figure 50.

It is important that the various leads to the potentiometers and switches *not* be cabled together for the sake of appearance.

CHAPTER TWENTY-THREE

Workshop Practice

With a few possible exceptions such as fixed air condensers and wirewound transmitting coils, it hardly pays one to attempt to build the components required for the construction of an amateur transmitter. This is especially true when the parts are of the type used in construction and replacement work on b.c.l. receivers, as mass production has made these parts very inexpensive.

Transmitters. Those who have and wish to spend the necessary time can effect considerable monetary saving in their transmitters by building them from the component parts. The necessary data are given in the construction chapter of this handbook.

To many builders, the construction is as fascinating as the operation of the finished transmitter; in fact, many amateurs get so much satisfaction out of building a well-performing piece of equipment that they spend more time constructing and rebuilding equipment than they do operating the equipment on the air.

Those who are not mechanically minded and are more interested in the pleasures of working dx and rag chewing than in experimentation and construction will find on the market many excellent transmitters which require only line voltage and an antenna. If you are one of those amateurs, you will find little to interest you in this chapter.

Receivers. There is room for argument as to whether one can save money by constructing his own communications receiver. The combined demand for these receivers by the government, amateurs, airways, short-wave listeners and others has become so great that it may be argued that there is no more point in building such a receiver than in building a regular broadcast set. Yet, many amateurs still prefer to construct their own receivers—in spite of the fact that it costs almost as much to build a receiver as to purchase an equivalent factory made job—either because they enjoy construction work and take pride in the fruits of their efforts, or because the receiver must

meet certain specifications and yet cost as little as possible.

The only factory produced receiver that is sure to meet the requirements of every amateur or short-wave listener is the rather expensive de luxe type having every possible refinement. An amateur of limited means who is interested only in c.w. operation on two or three bands, for instance, can build himself at a fraction of the cost of a de luxe job a receiver that will serve his particular purpose just as well. In the receiver construction chapter are illustrated several relatively inexpensive receivers which, for the particular purpose for which they were designed, will perform as well as the costliest factory built receiver.

Types of Construction

Breadboard. The simplest method of constructing equipment is to lay it out in breadboard fashion, which consists of screwing the various components to a board of suitable size, arranging parts so the important leads will be as short as possible.

While this type of construction is also adaptable to receivers and measuring and monitoring equipment, it is used principally for transmitter construction and remains a favorite of the c.w. amateurs using high power.

Breadboard construction requires a minimum of tools; apparatus can be constructed in this fashion with the aid of only a rule, screwdriver, ice pick, saw and soldering iron. A hand drill will also be required if it is desired to run part of the wiring underneath the breadboard. Ordinary carpenter's tools will be quite satisfactory.

Danger from accidental electrical shock usually is greatest with this type construction because of the exposed components.

Metal Chassis. Though quite a few more tools and considerably more time will be required for its construction, much neater equipment can be built by mounting the parts on

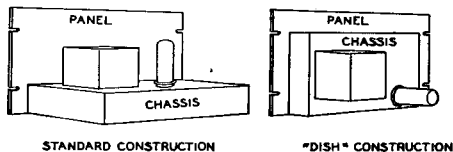

Figure 1.

TWO TYPES OF RACK-AND-PANEL CONSTRUCTION.

sheet metal chassis instead of breadboards. This type of construction is advisable when shielding of the apparatus is necessary, as breadboard construction does not particularly lend itself to shielding. The appearance of the apparatus may be further enhanced by incorporating a front panel upon which the various controls are placed. A front panel minimizes the danger of shock.

If sufficient pains are taken with the construction and a front panel is used in conjunction with either a dust cover (cabinet) or enclosed relay rack, the apparatus can be made to resemble or even to rival factory built equipment in appearance.

Dish type construction is practically the same as metal chassis construction, the main difference lying in the manner in which the chassis is fastened to the panel. Examples of both types are shown in figure 1.

Special Frameworks. For high powered r.f. stages, many amateur constructors prefer to discard the more conventional types of construction and employ instead special metal frameworks and brackets which they design specially for the parts which they intend to use. These are usually arranged to give the shortest possible r.f. leads and to fasten directly behind a relay rack panel by means of a few bolts, with the control shafts projecting through corresponding holes in the panel.

Tools

Beautiful work can be done with metal chassis and panels with the help of only a few inexpensive tools. However, the time required for construction will be greatly reduced if a fairly complete assortment of metal working tools is available. Thus, it can be seen that while an array of tools will speed up the work, excellent results may be accomplished with but few tools, if one has the time and patience.

The investment one is justified in making in tools is dependent upon several factors. If you like to tinker, there are many tools useful in radio construction that you would probably buy anyway, or perhaps already have, such

as screwdrivers, hammer, saws, square, vise, files, etc. This means that the money taken for tools from your radio budget can be used to buy the more specialized tools, such as socket punches or hole saws, taps and dies, etc.

The amount of construction work one does determines whether buying a large assortment of tools is an economical move. It also determines if one should buy the less expensive type offered at surprisingly low prices by the familiar mail order houses, "five and ten" stores and chain auto-supply stores, or whether one should spend more money and get first-grade tools. The latter cost considerably more and work but little better when new, but will outlast several sets of the cheaper tools. Therefore they are a wise investment for the experimenter who does lots of construction work (if he can afford the initial cash outlay). The amateur who constructs only an occasional piece of apparatus need not be so concerned with tool life, as even the cheaper grade tools will last him several years, if they are given proper care.

The hand tools and materials in the accompanying lists will be found very useful around the home workshop. Materials not listed but ordinarily used, such as paint, can best be purchased as required for each individual job.

ESSENTIAL HAND TOOLS AND MATERIALS

- 1 Good electric soldering iron, about 100 watts, with "radio" tip
- 1 Spool rosin-core wire solder
- 1 Jar soldering paste (non-corrosive)
- 1 Ea. large, medium, small and midjet screwdrivers
- 1 Good handdrill (eggbeater type), preferably two speed
- 1 Pr. regular pliers, 6 inch
- 1 Pr. long nose pliers, 6 inch
- 1 Pr. cutting pliers (diagonals), 5 inch or 6 inch
- 1 1½ inch tube-socket punch
- 1 "Boy Scout" knife
- 1 Combination square and steel rule, 1 ft.
- 1 Yardstick or steel pushrule
- 1 Scratch awl or ice pick scribe
- 1 Center punch
- 1 Doz. or more assorted round shank drills (as many as you can afford between no. 50 and ¼ or ⅜ inch, depending upon size of hand drill chuck)
- 1 Combination oil stone
- Light machine oil (in squirt can)
- Friction tape

HIGHLY DESIRABLE HAND TOOLS AND MATERIALS

- 1 Good ball peen hammer, ¾ or 1 lb.
- 1 Hacksaw with coarse and fine blades, 10 or 12 inch.

- 1 Bench vise (jaws at least 3½ inch)
- 1 Spool plain wire solder
- 1 Carpenter's brace, ratchet type
- 1 Square-shank countersink bit
- 1 Square-shank countersink
- 1 Square-shank taper reamer, small
- 1 Square-shank taper reamer, large (the two reamers should overlap; ½ inch and ⅞ inch size will usually be suitable.)
- 1 ⅞ inch tube-socket punch (for electrolytic condensers)
- 1 Square-shank adjustable circle cutter for holes to 3 inch
- 1 Set small, inexpensive, open-end wrenches
- 1 Pr. tin shears, 10 or 12 inch
- 1 Cold chisel (½ inch tip)
- 1 Wood chisel (½ inch tip)
- 1 Pr. wing dividers
- 1 Coarse mill file, flat, 12 inch
- 1 Coarse bastard file, round, ½ or ¾ inch dia.
- 6 or 8 assorted small files: round, halfround, triangular, flat, square, rat-tail, etc.
- 4 Small "C" clamps
- Steel wool, coarse and fine
- Sandpaper and emery cloth, coarse, medium and fine
- Rubber cement
- File card or stiff brush

USEFUL BUT NOT ESSENTIAL TOOLS AND MATERIALS

- 1 Cheap carpenter's claw hammer
- 1 Jig or scroll saw (small) with metal-cutting blades
- 1 Small wood saw (crosscut teeth)
- 1 Ea. square-shank drills: ⅜ ⅞ and ½ inch
- 1 Tap and die outfit for 6-32 and 8-32 machine screw threads. (A complete set is not necessary as other sizes will be seldom needed.)
- 4 Medium size "C" clamps
- Lard oil (in squirt can)
- Kerosene
- Duco or polystyrene cement (coil dope)
- Empire cloth
- Alcohol
- Clear lacquer ("industrial" grade)
- Lacquer thinner
- Dusting brush
- Paint brushes
- Sheet celluloid, Lucite, or Polystyrene
- Acetone
- 1 Carpenter's plane, 8 inch or larger
- 1 Metal punch
- 1 Ea. "Spintite" wrenches, ¼ and ⅝ inch to fit standard 6-32 and 8-32 nuts used in radio work and two common sizes of Parker Kalon metal screws

The foregoing assortment assumes that the constructor does not want to invest in the more expensive power tools, such as drill press, grinding head, etc. If power equipment is

purchased, obviously some of the hand tools and accessories listed will be superfluous. A drill press greatly facilitates construction work, and it is unfortunate that a good one costs as much as a small transmitter. A booklet* available from the Delta Manufacturing Co. will be of considerable aid to those who have access to a drill press.

Not listed in the table are several special-purpose radio tools which are somewhat of a luxury but are nevertheless quite handy, such as various around-the-corner screwdrivers and wrenches, special soldering iron tips, etc. These can be found in the larger radio parts stores and are usually listed in their mail order catalogs. It is not uncommon to find amateurs who have had sufficient experience as machinists to design and produce tools for special purposes.

Tool Hints

Of equal importance in maintaining one's supply of necessary tools and assorted materials is the assignment of each tool to one particular location. The greatest loss of time in any shop is usually incurred by searching for tools which are not in their proper place

Amateurs in or near the larger cities will often find it profitable to visit that section of the city where may be found many large stores that deal in used machinery and tools. It is quite commonplace to find used tools of high quality in good condition at a low price.

Soldering Irons. A prerequisite to a good soldering job is a good iron. If one can afford two irons, a 150-watt size for heavy work and a smaller 75-watt size for light work and getting into tight places are highly desirable. However, a single 100-watt iron will do nicely for most purposes.

Do not get a high wattage iron that is relatively small physically. Such an iron must be used continuously to keep it from becoming too hot. When such an iron is left plugged in and is not used for several minutes, the iron will become so hot that it will curdle the solder adhering to the tip, making frequent filing and retinning necessary. An aluminum rest which presents considerable surface to the air and to the iron will prevent an iron from becoming overheated when not in actual use. Such a heat-dissipating rest for the iron can be made from an old aluminum automobile piston by sawing it off diametrically at the center of the wrist pin hole.

* "Getting the Most Out of Your Drill Press," James Tate, Delta Manufacturing Company, Milwaukee, Wisconsin.

For occasional extremely heavy work, a ten-cent store, gas-heated iron will be found very useful. This type of iron is merely a heavy copper tip fastened to a steel rod which has a wooden handle. Since the mass of the tip is great, it will hold heat for a long time, and is just the thing for working on large, heavy gauge subpanels, and on antennas where no current is available for an electric iron nearby. If heated sufficiently they can be carried for considerable distance before becoming too cold for satisfactory soldering work.

An alternative for soldering joints at a distance from an a.c. power source is a small alcohol torch, obtainable for about 75 cents.

Wood Saws. There are many types of wood saws on the market, but for amateur construction work those listed in the tool tables are usually sufficient. Saws will work much better and last much longer if properly cared for. Keep the blades in good shape by smearing them with a thin film of vaseline after they are used. A rusty saw will not do good work. When it becomes necessary, as it does from time to time, to have them sharpened, let a good joiner do the work; it is a job for an expert, usually available in local hardware stores.

Metal Saws. The hacksaw has become an almost universally standardized tool for the amateur workshop. The replaceable blades are obtainable with varying numbers of teeth. The coarse blades, having 14 or 18 teeth per inch, can be used for bakelite or ebonite; for most metals, a medium tooth blade with about 22 teeth per inch is desirable; and for very thin sheets a blade having 32 teeth per inch is best. Ordinarily, the harder the metal, the finer the blade that should be used.

When replacing saw blades, keep in mind that hacksaw blades should be put in place with the teeth pointing *towards the tip* of the saw, while jig or scroll saw blades should have the teeth *towards the handle*, in order to keep the work pressed on the cutting bench.

Files. When using a file the handle should be grasped firmly in the right hand, with the thumb on top, and the left hand should rest on the tip to guide it. The pressure should be eased off the left hand and transferred on to the right hand as the file proceeds across the work. The return stroke should be made with a minimum amount of pressure, or better, with the file raised from the work. The file should be cleaned often, both during and after work, in order to remove the filings which stick to the teeth. These may scratch the work if allowed to remain. A "file card" is inexpensive and will remove the burrs quickly.

To Resharpen Old Files. Wash the files in warm potash water to remove the grease and dirt, then wash in warm water and dry by heat. Put one and one-half pints warm water in a wooden vessel, put in the files, add three ounces blue vitriol finely powdered, and three ounces borax. Mix well and turn the files so that every one may come in contact with the mixture. Add ten and one-half ounces sulphuric acid and one-half ounce cider vinegar. Remove the files after a short time, dry, rub with olive oil, wrap in porous paper. Coarse files should be kept in the mixture for a longer time than fine ones.

File Lubricant. When filing aluminum, dural, etc., the file should be oiled or rubbed in chalk, but will cut slower than with no lubricant. However, the file will last much longer.

Screwdrivers. Screwdrivers call for little comment. The tips are important if the screw heads are to remain undamaged, however. They should fit the heads properly, not too loose, not too tight. They can be sharpened with a fine file, taking care that tip is parallel and the end square. If filed too thin, they will be weak; if filed at an angle, they will tend to jump out of the sawcut and damage the screw.

Screw Lubricant. Put hard soap on lag screws, wood screws or any screw for wood. It will surprise you how much easier they will turn in. The soap also will prevent or at least reduce splitting.

Power Drills and Drilling. Although most of us do not so consider it, a twist drill is nothing more than a modified jackknife. It has a cutting edge, an angle of clearance and an angle of rake, just as has a jackknife (or a lathe tool). The technique to be followed in drilling is, therefore, a function of the type of material worked on, as well as the speed and accuracy desired. As the drill proceeds, a chip cut out is about the cutting edge. This has the effect of pushing the drill farther into the material. This is determined by the "angle of rake" and the hardness of the material. If the material is hard at the point of cutting, the resistance to downward motion here is great enough to overcome that generated by the angle of rake.

For steel or iron, the shavings which come out of the hole around the drill should be spiral and continuous. For softer metals, especially brass, the drill should have no angle of rake (or lip, as the forward projecting cutting edge is called). The shavings for this drill will be small chips. If this shape drill is not used, the drill will feed into the metal very rapidly and will usually jam.

As the tip of a drill is not a point, but a straight line perpendicular to its major axis, a

drill will usually waltz all over before it starts to drill unless a guide hole is punched at the point you wish to drill. The maximum diameter of this hole should be at least equal to the width of the drill tip. A center punch impression will suffice for small holes. With drills of over $\frac{1}{4}$ -inch diameter, this method of starting the drill is usually impractical as the diameter of the center-punch hole is prohibitively large. This difficulty is avoided by first drilling a smaller guide hole which can be started with a center-punch hole.

A great deal could be said about drilling speeds and feeds, but it would be of little value to the average person. Just remember that in drilling steel or iron, the drill point should be well lubricated with lard oil or a medium grade of machine oil. The weight of oil commonly used in oiling lawn mowers is about correct. This serves a double function for most machinists. The first, of course, is lubrication. The second is to keep the work cool. The oil flows from hot points to cold ones more quickly than heat flows from the hot points of the drill to the cooler ones. But, for amateur use, the oil assumes a third role, that of a temperature indicator. The oil should never evaporate visibly to form a cloud around the work (this vapor looks like steam).

Another indicator is that you should be able to hold the end of the drill in your hand with no discomfort immediately after you have finished the hole. These considerations are based on the assumption that most hams use the average carbon drill, and not one of the more expensive type designed to operate at high temperatures. Most tool steel will start to lose its hardness at a little over 100 degrees C. At 600 degrees, it is as soft as mild steel, and must be heat treated and tempered again. That means that most hams would have to grind the softened portion off and then attempt to regrind the cutting edges.

Brass should always be drilled with no lubricant. For one thing, the brass slides readily against steel. Bronze is in the same class. Witness the large number of bronze bearings in current use. Almost all of the zinc alloys may so be treated. If a lubricant is used, it usually only makes the particles cling together and thus clog up the drill point. Aluminum and its alloys are sometimes lubricated with kerosene or milk.

The drill speed (number of revolutions per minute of the drill) and the drilling feed (rate at which the drill is pushed into the work) are interdependent. The safe, simple way to determine them is to watch the temperature. If the drill is running too hot, decrease the feed. If it still runs too hot, decrease the

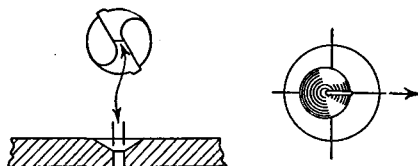

Figure 2.
STARTING THE DRILL.

A drill should always be started with a center punch impression or small hole that is at least as large as the flat portion of the drill tip. If the guide hole is a little off, the drill can be "fudged over" by means of a chisel mark as shown to the right.

speed. In drilling, it is a safe practice never to feed the drill in a distance greater than the diameter of the drill without backing it off until the work is clear. This permits you to examine the point and permits the drill to clear itself of particles which may be clogging it at the point of cutting. This looks like a waste of time, but actually will be a time saver. You won't have to stop to replace broken and softened drills.

The desired speed for drilling depends on size of hole, kind of stock, rate of feed, etc. A typical job for a ham would be a lot of No. 27 or No. 19 holes in a steel chassis. The second speed on most drills, or about 1200 r.p.m., is about right. For electrical alloy or aluminum a step faster might be used. The 2400 r.p.m. pulley can be used for drills like No. 36 and smaller. First speed, usually about 600 r.p.m., will make those $\frac{3}{8}$ " and $\frac{1}{2}$ " holes. There are tables available about cutting speeds in feet per minute, etc., but experience can best tell you if the speed is right. The speed must match the feed—cut a continuous chip—and the drill should not run hot.

Plastics. One can get excellent r.f. insulation in various forms and prepare it with only a little more trouble than our old standby, bakelite. There are two kinds of Mycalex. The kind on Cardwell condensers is known as G.E.1364; then there is a softer kind called leadless, which drills easier, but is more apt to chip and crack. The G.E.1364 kind can be bought in strips of various sizes, and the strips cut up with a hack saw. Sawing a wide piece would be laborious.

Drilling a piece of Mycalex is like drilling a piece of stone, and drills are bound to dull rapidly. There are special drills known as Fosdick drills that can be used to advantage if any great amount is to be drilled. Ordinary twist drills will do if they are sharpened after every hole or two. The powder which results

from drilling must be removed by blowing, as fast as it forms. Another way to remove the powder is to drill the piece submerged in water. The powder will float to the top and not clog the drill. Just to lubricate the drill with water or oil in the usual way will make things worse however. Then the powder will form a paste around the drill. Better to drill dry, with slow speed and frequent stops

for cleaning the drill and hole. When the drill point starts to break through, the work should be turned over and finished on the reverse side to prevent chipping.

Lucite and polystyrene products like "Victron," "912-B" etc., drill and tap as easily as bakelite except for their notorious susceptibility to heat. Drilling speeds can be about the same as for brass or bakelite; slower if heating results. When drilling through a thick piece of the transparent kind you can see the side wall of the hole turn white and flaky if the point warms up. A little of this roughness isn't objectionable, but keep the point cool. Drills must be sharp, and the flutes kept clear of chips. Frequent sharpening is not necessary as these plastics are very easy on tools. If any quantity is to be worked, special "bakelite drills" with coarse flutes can be used. Some of these materials are more flexible than others; but it isn't wise to hit the center punch too hard. Use soap and water to wash the work after handling.

Danger. Most drill presses are equipped with some means of clamping the work. It is always wise to use these, unless the piece is large and the holes are small. A piece, especially of sheet steel, which gets jammed on the drill and tears out of the operator's hands, is a dangerous weapon. With small pieces, it is always best to clamp them in a tool maker's vise.

When working with sheet steel (as you usually are on chassis construction), if the piece is large, you may hold it safely by hand. Wear gloves and hold the work *firmly* with both hands. The drill feed may be easily arranged to operate by foot for these operations.

Steel parallels are indispensable when the piece to be drilled is irregular. Under a panel or chassis parallels have advantages over a block. First, they are more accurate. Then, as the work progresses, they can be moved about so as to miss the burrs that accumulate on the under side. Work that is laid flat on a block or table often gets tilted because of such burrs. Real parallels are expensive, but there are cheaper substitutes: pieces of cold-rolled steel bar and printers' "iron furniture" make excellent parallels.

Construction Practice

Chassis Layout. The chassis should first be covered with a layer of wrapping paper, which is drawn tightly down on all sides and fastened with scotch tape. This allows any number of measurement lines and hole cen-

NUMBERED DRILL SIZES

DRILL NUMBER	Di- ameter (in.)	Clears Screw	Correct for Tapping Steel or Brass †
1	.228	—	—
2	.221	12-24	—
3	.213	—	14-24
4	.209	12-20	—
5	.205	—	—
6	.204	—	—
7	.201	—	—
8	.199	—	—
9	.196	—	—
10*	.193	10-32	—
11	.191	10-24	—
12*	.189	—	—
13	.185	—	—
14	.182	—	—
15	.180	—	—
16	.177	—	12-24
17	.173	—	—
18*	.169	8-32	—
19	.166	—	12-20
20	.161	—	—
21*	.159	—	10-32
22	.157	—	—
23	.154	—	—
24	.152	—	—
25*	.149	—	10-24
26	.147	—	—
27	.144	—	—
28*	.140	6-32	—
29*	.136	—	8-32
30	.128	—	—
31	.120	—	—
32	.116	—	—
33*	.113	4-36 4-40	—
34	.111	—	—
35*	.110	—	6-32
36	.106	—	—
37	.104	—	—
38	.102	—	—
39*	.100	3-48	—
40	.098	—	—
41	.096	—	—
42*	.093	—	4-36 4-40
43	.089	2-56	—
44	.086	—	—
45*	.082	—	3-48

† Use next size larger drill for tapping bakelite and similar composition materials (plastics, etc.).

* Sizes most commonly used in radio construction.

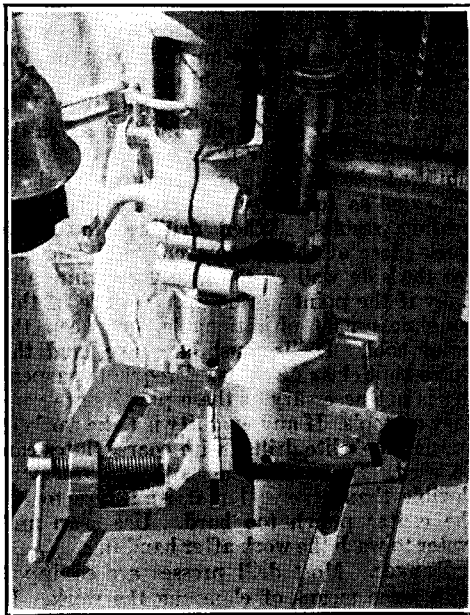

Figure 3.

DRILL PRESS VISE.

Small objects are best handled on a drill press by means of a drill press vise.

ters to be spotted in the correct positions without making any marks on the chassis itself. Place on it the parts to be mounted and play a game of chess with them, trying different arrangements until all the grid and plate leads are made as short as possible, tubes are clear of coil fields, r.f. chokes are in safe positions, etc. Remember, especially if you are going to use a panel, that a good mechanical layout can often accompany sound electrical design, but that the electrical design should be given first consideration.

All too often parts are grouped to give a symmetrical panel irrespective of the arrangement behind. When a satisfactory arrangement has been reached, the mounting holes may be marked. The same procedure must now be followed for the underside, always being careful to see that there are no clashes between the two (that no top mounting screws come down into the middle of a paper condenser on the underside, that the variable condenser rotors do not hit anything when turned, etc.).

When all the holes have been spotted, they should be center-punched *through* the paper into the chassis. Don't forget to spot holes for leads which must also come through the

chassis. For transformers which have lugs on the bottoms, the clearance holes may be spotted by dressing the transformer on a piece of paper to obtain impressions, which may then be transferred to the chassis.

Punching. In cutting socket holes, one can use either a fly-cutter or socket punches. These punches are easy to operate and only a few precautions are necessary. The guide pin should fit snugly in the guide hole. This increases the accuracy of location of the socket. If this is not of great importance, one may well use a drill of $1/32$ " larger diameter than the guide pin. Some of the punches will operate without guide holes, but the latter always make the punching operation simpler and easier. The only other precaution is to be sure the work is properly lined up before applying the hammer. If this is not done, the punch may slide sideways when you strike and thus not only shear the chassis but also take off part of the die. This is easily avoided by always making sure that the piece is parallel to the faces of the punch, the die and the base. The latter should be an anvil or other solid base of heavy material.

A punch by *Greenlee* forces socket holes through the chassis by means of a screw turned with a wrench. It is noiseless, and works much more easily and accurately than most others. It requires the use of a $3/8$ -inch center hole to accommodate the screw.

Transformer Cutouts. Cutouts for transformers and chokes are not so simply handled. After marking off the part to be cut, drill about a $1/4$ " hole on each of the inside corners and tangential to the edges. After burring the holes, clamp the piece and a block of cast iron or steel in the vise. Then, take your burring chisel and insert it in one of the corner holes. Cut out the metal by hitting the chisel with a hammer. The blows should be light and numerous. The chisel acts against the block in the same way that the two blades of a pair of scissors work against each other. This same process is repeated for the other sides. A file is used to trim up the completed cutout.

Another method is to drill the four corner holes large enough to take a hack saw blade, then saw instead of chisel. The four holes permit nice looking corners.

Removing Burrs. In both drilling and punching, a burr is usually left on the work. There are three simple ways of removing these. Perhaps the best is to take a chisel (be sure it is one for use on metal) and set it so that its bottom face is parallel to the piece. Then gently tap it with a hammer. This usually will make a clean job with a

little practice. If one has access to a counter-bore, this will also do a nice job. A counter-sink will work, although it bevels the edges. A drill of several sizes larger is a much used arrangement. The third method is by filing off the burr, which does a good job but scratches the adjacent metal surfaces badly.

Mounting Components. There are two methods in general use for the fastening of transformers, chokes, and similar pieces of apparatus to chassis or breadboards. The first, using nuts and screws, is slow, and the commercial manufacturing practice of using self-tapping screws is gaining favor. For the mounting of small parts such as resistors and condensers, tie strips are very useful to gain rigidity. They also contribute materially to the appearance of finished apparatus.

Grommets of the proper size placed in all chassis holes through which wires are to be passed will give a neater appearing job and will also reduce the possibility of short circuits.

Soldering. Making a strong, low-resistance solder joint does not mean just dropping a blob of solder on the two parts to be joined and then hoping that they'll stick. There are several definite rules that *must* be observed.

All parts to be soldered must be absolutely clean. To clean a wire, lug, or whatever it may be, take your pocket knife and scrape it thoroughly, until fresh metal is laid bare. It is not enough to make a few streaks; scrape until the part to be soldered is bright.

Make a good mechanical joint before applying any solder. Solder is intended primarily to make a good electrical connection; mechanical rigidity should be obtained by bending the wire into a small hook at the end and nipping it firmly around the other part, so that it will hold well even before the solder is applied.

Keep your iron properly tinned. It is impossible to get the work hot enough to take the solder properly if the iron is dirty. To tin your iron, file it, while hot, on one side until a full surface of clean metal is exposed. Immediately apply rosin core solder until a thin layer flows completely over the exposed surface. Repeat for the other faces. Then take a clean rag and wipe off all excess solder and rosin. The iron should also be wiped frequently while the actual construction is going on; it helps prevent pitting the tip.

Apply the solder to the work, not to the iron. The iron should be held against parts to be joined until they are thoroughly heated. The solder should then be applied against the

parts, and the iron should be held in place until the solder flows smoothly and envelopes the work. If it acts like water on a greasy plate, and forms a ball, the work is not sufficiently clean.

The completed joint must be held perfectly still until the solder has had time to solidify. If the work is moved before the solder has become completely solid, a "cold" joint will result. This can be identified immediately, because the solder will have a dull "white" appearance rather than one of shiny "silver." Such joints tend to be of high resistance, and will very likely have a bad effect upon a circuit. The cure is simple: Merely reheat the joint and do the job correctly.

Wipe away all surplus flux when the joint has cooled if you are using a paste type flux. Be sure it is non-corrosive, and use it with plain (not rosin core) solder.

Finishes. If the apparatus is constructed on a painted chassis (commonly available in black crackle and gray crackle), there is no need for application of a protective coating when the gear is finished, assuming that you are careful not to scratch or mar the finish while drilling holes and mounting parts. However, many amateurs prefer to use unpainted (zinc or cadmium plated) chassis, because it is much simpler to make a chassis ground connection with this type of chassis. A thin coat of clear "linoleum" lacquer may be applied to the whole chassis after the wiring is completed to retard rusting. In localities near the sea coast it is a good idea to lacquer the various chassis cut-outs even on a painted chassis, as rust will get a good start at these points unless the metal is protected where the drill or saw has exposed it. If too thick a coat is applied, the lacquer will tend to peel. It may be thinned with lacquer thinner to permit application of a light coat. A thin coat will adhere to any clean metal surface that is not too shiny.

An attractive dull gloss finish, almost velvety, can be put on aluminum by sand-blasting it with a very weak blast and fine particles and then lacquering it. Soaking the aluminum in a solution of lye produces somewhat the same effect as a fine grain sand blast.

There are also several brands of dull gloss black enamels on the market which adhere well to metals and make a nice appearance. Air-drying crackle finishes are sometimes successful, but a baked job is usually far better. Crackle finishes, properly applied, are very durable and are pleasing to the eye. If you live in a large community, there is probably an enamelling concern which can crackle your

work for you at a reasonable cost. A very attractive finish for panels especially is to spray a crackle finish with aluminum paint. In any painting operation (or plating, either, for that matter), the work should be very thoroughly cleaned of all greases and oils.

To protect brass from tarnish, thoroughly cleanse and remove the last trace of grease by the use of potash and water. The brass must be carefully rinsed with water and dried; but in doing it, care must be taken not to handle any portion with the bare hands nor anything else that is greasy. Then lacquer.

Drilling Glass. This is done very readily with a common drill by using a mixture of turpentine and camphor. When the point of the drill has come through, it should be taken out and the hole worked through with the point of a three-cornered file, having the edges ground sharp. Use the corners of the file, scraping the glass rather than using the file as a reamer. Great care must be taken not to crack the glass or flake off parts of it in finishing the hole after the point of the drill has come through. Use the mixture freely during the drilling and scraping. The above mixture will be found very useful in drilling hard cast iron.

Etching Solution. Add three parts nitric acid to one part muriatic acid. Cover the piece to be etched with beeswax. This can be done

by heating the piece in a gas or alcohol flame and rubbing the wax over the surface. Use a sharp steel point or hard lead pencil point as a stylus. A pointed glass dropper can be used to put the solution at the place needed. After the solution foams for two or three minutes, remove with blotting paper and put oil on the piece and then heat and remove the wax.

Chromium Polish. So much chromium is now used in radio sets and on panels that it is well to know that this finish may be polished. The only materials required are absorbent cotton or soft cloth, alcohol and ordinary lampblack.

A wad of cotton or the cloth is moistened in the alcohol and pressed into the lampblack. The chromium is then polished by rubbing the lampblack adhering to the cotton briskly over its surface. The mixture dries almost instantly and may be wiped off with another wad of cotton.

The alcohol serves merely to moisten the lampblack to a paste and make it stick to the cotton. The mixture cleans and polishes very quickly and cannot scratch the chromium surface. It polishes nickel-work just as effectively as it does chromium. Care should be taken to see that the lampblack does not contain any hard, gritty particles which might produce scratches during the polishing.

CHAPTER TWENTY-FOUR

Broadcast Interference

Amateur signals which intrude upon a broadcast program constitute a nuisance to which disturbed listeners are bound to object vigorously.

Broadcast interference is a matter of grave importance to all amateurs. Indeed, an amateur station license is placed in considerable jeopardy by repeated citations of interference with broadcast or other commercial stations. The FCC regulations are particularly severe in this respect, and they require that the offending amateur correct the trouble or keep off the air during specified hours of the day or night.

In general, signals from a transmitter operating properly are not picked up by receivers tuned to other frequencies unless the receivers are of inferior design, or are in a decidedly poor state of alignment. Therefore, if the receiver is of good design and is in good repair, the burden of rectifying the trouble rests with the operator of the interfering station.

Phone and c.w. stations both are capable of causing broadcast interference, key-click annoyance from code transmitters being particularly objectionable. The elimination of key clicks is fully covered in *Chapter Seven*.

A knowledge of each of the several types of broadcast interference, their cause and methods of eliminating them is necessary to the successful disposition of this trouble. An effective method of combatting one variety of interference is often of no value whatever in the correction of another type. Broadcast interference seldom can be cured by "rule of thumb" procedure.

Interference Classifications

Depending upon whether it is traceable directly to causes within the *station* or within the *receiver*, broadcast interference may be divided into two main classes. For example, that type of interference due to

transmitter overmodulation is at once listed as being caused by improper operation, while an interfering signal that tunes in and out with a broadcast station is probably an indication of cross-talk in the receiver, and the poorly-designed input stage of the receiver is held liable. The various types of interference and recommended cures will be discussed separately.

Blanketing. This is not a tunable effect, but a total blocking of the receiver. A more or less complete "washout" covers the entire receiver range when the carrier is switched on. This produces either a complete blotting out of all broadcast stations, or else knocks down their volume several decibels—depending upon the severity of the interference. Voice modulation of the carrier causing the blanketing will be highly distorted or even unintelligible. Keying of the carrier which produces the blanketing will cause an annoying fluctuation in the volume of the broadcast signals.

Blanketing generally occurs in the immediate neighborhood (inductive field) of a powerful transmitter, the affected area being directly proportional to the power of the transmitter. This type of interference occurs most frequently where the receiver uses an outside antenna which happens to resonate at a frequency close to that of the offending transmitter. Also it is more prevalent with transmitters which operate in the 80- and 160-meter bands, than with those on the higher frequencies.

The remedies are to (1) shorten the receiving antenna, and thereby shift its resonant frequency, or (2) remove it to the interior of the building, (3) change the direction of either the receiving or transmitting antenna to minimize their mutual coupling, or (4) keep the interfering signal from entering the receiver input circuit by installing a wave-trap tuned to the signal frequency (see figure 1).

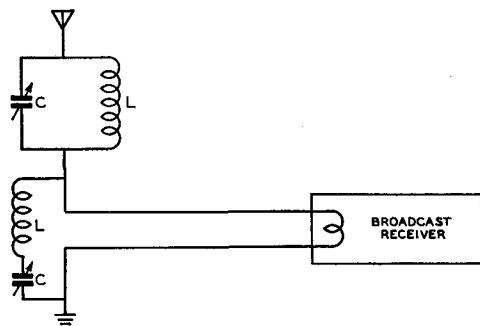

Figure 1.
EFFECTIVE WAVE TRAP CIRCUIT
FOR HIGH ATTENUATION OF INTERFERING SIGNAL REACHING RECEIVER VIA ANTENNA.

This type of trap works at full efficiency over but a small range in frequency, and therefore is not effective when several interfering signals of widely different frequencies are present. When only moderate attenuation is required, a single tank (either series or shunt) will often suffice. For coil and condenser values refer to figure 3.

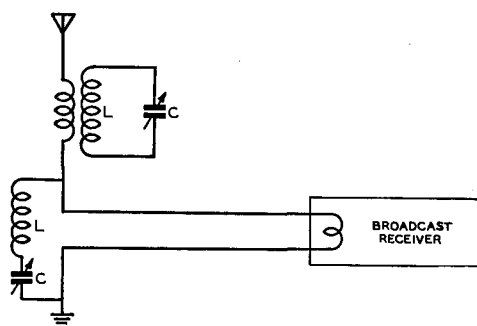

Figure 2.
MODIFICATION OF CIRCUIT SHOWN
IN FIGURE 1.

In this case the parallel resonant tank is coupled to the antenna with 3 to 6 turns of wire instead of being placed in series with the antenna lead. It gives slightly better performance than the circuit of figure 1 with certain antennas.

A suitable wave-trap is quite simple in construction, consisting only of a coil and midget variable condenser. When the trap circuit is tuned to the frequency of the interfering signal, little of the interfering voltage reaches the grid of the first tube.

The wave-trap must be installed as close to the receiver antenna terminal as practicable, hence it should be as small in size as possible. The variable condenser may be a midget air-tuned trimmer type and the coil may be wound on a 1-inch dia. form. The table of figure 3 gives winding data for wave-traps built around a 50- $\mu\text{mfd.}$ variable condenser. For best results both a shunt and a series trap should be employed as shown.

Figure 2 shows a two-circuit coupled wave-trap that is somewhat sharper in tuning and more efficacious. The specifications for the coil L_2 may be obtained from the table in figure 3. The primary, L_1 , consists of three to five closewound turns of the same size wire wound in the same direction on the same form as L_2 and separated from the latter by one-eighth of an inch.

Overmodulation. A carrier modulated in excess of 100 per cent acquires sharp cut-off periods (figure 4) which give rise to high damping. This creates a broad signal and often generates spurious frequencies at odd places on the dial. High damping of a radiotelephone signal may at the same time bring about impact or shock excitation of

nearby receiving antenna and power lines, transmitting interfering voltages in that manner.

Broadcast interference due to overmodulation is generally common to 160- and 75-meter operation. The remedy is to reduce the modulation percentage.

Cross Modulation. Cross modulation or "cross talk" is characterized by the amateur signal "riding in" on top of strong local broadcasts. There is usually no heterodyne note, the amateur signal being tuned in and out with the program carriers.

Figure 3.
R. F. WAVE TRAP COIL AND CONDENSER TABLE

BAND	COIL L	CONDENSER C
160	41 turns No. 28 enameled close wound 1-inch form	50- $\mu\text{mfd.}$ variable shunted by 200- $\mu\text{mfd.}$ fixed mica.
80	41 turns No. 28 enameled close wound 1-inch form	50- $\mu\text{mfd.}$ variable
40	21 turns No. 24 enameled 11/16-inch long 1-inch form	50- $\mu\text{mfd.}$ variable
20	7 turns No. 24 enameled 5/16-inch long 1-inch form	50- $\mu\text{mfd.}$ variable
10	4 turns No. 24 enameled 5/16-inch long 1-inch form	50- $\mu\text{mfd.}$ variable

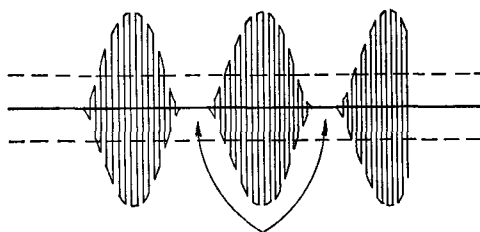

PRODUCES SAME EFFECT
AS RAPID KEY CLICKS

Figure 4.
ILLUSTRATING HIGH DAMPING
CHARACTERISTIC OF BADLY OVER-
MODULATED SIGNAL.

The resulting interference seldom can be cured by wave traps or line filters; it must be corrected at the transmitter.

This effect is due entirely to a faulty input stage in the affected receiver. Modulation of the interfering carrier will swing the operating point of the input tube. This type of trouble is seldom experienced when a variable- μ tube is used in the input stage.

Where the receiver is too ancient to incorporate such a tube, and is probably poorly shielded at the same time, it will be better to attach a wave-trap of the type shown in figure 1 than to attempt rebuilding of the receiver. The addition of a good ground and a shield can over the input tube often adds to the effectiveness of the wave-trap.

Transmission via Capacity Coupling.

A small amount of capacity coupling is now widely used in receiver r.f. and detector transformers as a gain booster at the high-frequency end of the tuning range. The coupling capacity is obtained by means of a small loop of wire cemented close to the grid end of the secondary winding, and with one end directly connected to the plate or antenna end of the primary winding (see figure 5).

From the relations of capacitive reactance, it is easily seen that a small condenser will favor the higher frequencies, and it is evident that capacity coupling in the receiver coils will tend to pass amateur short-wave signals into a receiver tuned to broadcast frequencies.

The amount of capacity coupling may be reduced to eliminate interference by moving the coupling turn farther away from the secondary coil. However, a simple wave-trap of the type shown in figures 1 and 2, inserted at the antenna input terminal, will generally accomplish the same result and is

more to be recommended than changing the capacity coupling (which lowers the receiver gain at the high frequency end of the broadcast band). Should the wave-trap alone not suffice, it will be necessary to resort to a reduction in capacity coupling.

In some simple broadcast receivers, capacity coupling is unintentionally obtained by too closely coupled primary and secondary coils or as a result of running a long primary or antenna lead close to the secondary coil of an unshielded antenna coupler.

Phantoms. When two strong local carriers are separated by a certain number of kilocycles, the beat note resulting between them may fall on some frequency within the broadcast band and, if rectified by any means, be audible at that point. If such a phantom signal falls on a local broadcast frequency, there will be heterodyne interference as well. This is a common occurrence with broadcast receivers in the neighborhood of two amateur stations, or an amateur and a police station. It also sometimes occurs when only one of the stations is located in the immediate vicinity.

As examples: the beat note between amateur carriers on 2000 kc. and 3500 kc. falls on 1500 kc., and an 1812-kc. amateur signal might beat with a local 1712-kc. police carrier to produce a 100-kc. phantom. And, if the latter two carriers are strong enough, harmonics will be encountered every 100 kilocycles throughout the broadcast band, that is, if rectification of the signals takes place anywhere in the vicinity. A poor contact between two oxidized wires can produce rectification.

Two stations must be transmitting simultaneously to produce a phantom signal; when either station goes off the air the phantom disappears. Hence, this type of interference is apt to be reported as highly intermittent and might be difficult to duplicate unless a test oscillator is used "on location" to simulate the missing station. Such interference cannot be remedied at the transmitter, and often the rectification takes place some distance from the receivers. In such occurrences it is most difficult to locate the source of the trouble.

It will also be apparent that a phantom might fall on the intermediate frequency of a simple superhet receiver and cause interference of the untunable variety if the manufacturer has not provided an i.f. wave-trap in the antenna circuit. Examples of this occurrence are the 175-kc. beat between 1887 (amateur) and 1712 kc. (police) or between amateur signals on 1820 kc. and 1995 kc.

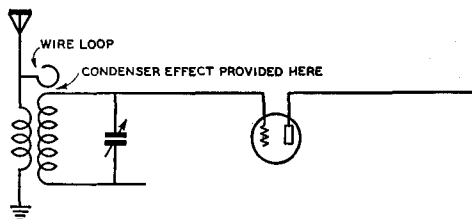

Figure 5.
TYPICAL AUXILIARY CAPACITY
COUPLING CIRCUIT USED IN B.C.
SETS TO BOOST GAIN AT 1500 KC.
END OF BAND.

Even though the coupling capacity may be small, it will have a fairly low reactance at high frequencies, and will aggravate interference from amateur stations, particularly those working on 14 and 28 Mc.

This particular type of phantom may, in addition to causing i.f. interference, generate harmonics which may be tuned in and out with heterodyne whistles from one end of the receiver dial to the other. It is in this manner that "birdies" often result from the operation of nearby amateur stations.

When one component of a phantom is a steady, unmodulated carrier, only the intelligence present on the other carrier is conveyed to the broadcast receiver.

Phantom signals almost always may be identified by the suddenness with which they are interrupted, signaling withdrawal of one party to the union. This is especially baffling to the inexperienced interference-locator who observes that the interference suddenly disappears, even though his own transmitter remains in operation.

If the mixing or rectification is taking place in the receiver itself, a phantom signal may be eliminated by removing either one of the contributing signals from the receiver input circuit. A wave-trap of the types shown in figures 1 and 2, tuned to either signal, will do the trick. If the rectification is taking place outside the receiver, the wave-trap should be tuned to the frequency of the phantom instead of to one of its components. I.f. wave-traps may be built around a 2.5-millihenry r.f. choke as the inductor and a compression-type mica padding condenser. The condenser should have a capacity range of 17-80 $\mu\text{mfd.}$ for the 175 and 206-ke. intermediate frequencies; 65-175 $\mu\text{mfd.}$ for 260 ke. and other intermediates lying between 250 and 400 ke.; and 250-525 $\mu\text{mfd.}$ for 456, 465, 495, and 500-ke. Slightly more capacity will be required for resonance with a 2.1 millihenry choke.

Spurious Emissions. This sort of interference arises from the transmitter itself. The radiation of any signal (other than the intended carrier frequency) by an amateur station is prohibited by FCC regulations. Spurious radiation may be traced to imperfect neutralization, parasitic oscillations in the r.f. or modulator stages, or to "broadcast-band" v.f.o.s.

Low-frequency parasitics may actually occur on broadcast frequencies or their near subharmonics, causing direct interference to programs. An all-wave monitor operated in the vicinity of the transmitter will detect these spurious signals.

The remedy will be obvious in individual cases. Elsewhere in this book are discussed methods of complete neutralization and the suppression of parasitic oscillations in r.f. and audio stages.

Stray Receiver Rectification. A receiver in the immediate neighborhood of a strong transmitter is subject to stray rectification within the receiver. It is due to the interfering signal being rectified by the second detector in a superhet (detector in a tuned r.f. set) or an audio stage of the receiver if poorly shielded or containing an excessively long grid lead.

This type of interference is most commonly caused by ultra-high-frequency transmitters, doubtless because at those frequencies lengthy connections in the receiver can easily become fractions of the transmitter wavelength. The interfering signal is not tunable, and generally covers the entire dial.

If the receiver is not a series-filament set, the trouble may be localized by removing the tubes, starting with the input stage and working toward the audio output stage. The interfering signal will cease when the tube rectifying it is removed from its socket.

Signal rectification in an audio stage may be cured by connecting a 2.5-millihenry pi-wound r.f. choke in series with the control-grid lead and input terminal and a .0001 $\mu\text{fd.}$ condenser from grid to ground. But the task is not so simple when rectification occurs in one of the other stages. Here, complete shielding of the set, tubes, and exposed r.f. leads (such as top-cap grid leads) will have to be provided. In addition, it may be necessary to lower the bias of the offending stage.

"Floating" Volume Control Shafts. Several sets have been encountered where there was only a slightly interfering signal; but, upon placing one's hand up to the volume control, the signal would greatly increase. Investigation revealed that the volume con-

BAND	COIL L	CONDENSER C
160	26 turns No. 14 enameled 4-inch diameter 3-inch length	100- μ fd. variable
80	17 turns No. 14 enameled 3-inch diameter 2 $\frac{1}{4}$ -inch length	100- μ fd. variable
40	11 turns No. 14 enameled 2 $\frac{1}{2}$ -inch diameter 1 $\frac{1}{2}$ -inch length	100- μ fd. variable
20	4 turns No. 10 enameled 3-inch diameter 1 $\frac{1}{8}$ -inch length	100- μ fd. variable
10	3 turns $\frac{1}{4}$ -inch o.d. copper tubing 2-inch diameter 1-inch length	100- μ fd. variable

Figure 6.

POWER-LINE WAVE TRAP COIL AND CONDENSER TABLE

trol was installed with its shaft insulated from ground. The control itself was connected to a critical part of a circuit, in many instances to the grid of a high-gain audio stage. The cure is to install a volume control with *all* the terminals insulated from the shaft, and then to ground the shaft.

Spray-Shield Tubes. Although they are no longer made, there are yet quite a few sets in use which employ spray-shield tubes. These are used in both r.f. and in audio circuits. In some audio applications of this type of tube, the cathode and the spray-shield (to which the cathode is connected) are not at ground potential, but are bypassed to ground with an electrolytic condenser of large capacity. This type of condenser is a very poor r.f. filter and, in a strong r.f. field, some detection will take place, producing interference. The best cure is to install a standard glass tube with a glove shield which is then actually grounded and also to shield the grid leads to these tubes. As an alternative, bypassing the electrolytic cathode condenser with a .05 μ fd. tubular paper condenser may be tried.

Power-Line Pickup. When radio-frequency energy from an amateur station enters a broadcast receiver through the a.c. power lines, it has either been fed back into the lighting system by the offending transmitter or picked up from the air by overhead power lines. Underground lines are seldom responsible for spreading this form of interference.

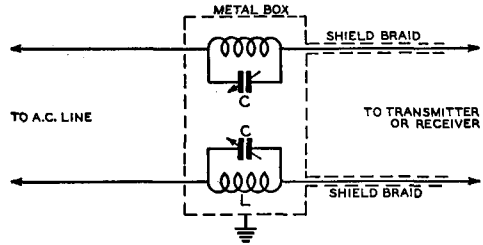

Figure 7.

METHOD OF CONNECTING POWER LINE WAVE TRAP.

A parallel resonant circuit is more effective than an r.f. choke in keeping r.f. from getting from a transmitter into the power line or from the power line into a receiver. A .05 μ fd. tubular condenser connected from each 110 volt wire to ground often will increase the effectiveness of the traps. They may be connected on either side of the line traps.

To check the path whereby the interfering signals reach the lines, it is only necessary to replace the transmitting antenna with a dummy antenna and adjust the transmitter for maximum output. If the interference then ceases, overhead lines have been picking up the energy. The trouble can be cleared up only by installing wave-traps in the power lines at the receiver. These are then tuned to the interfering signal frequency. If the receiver is reasonably close to the transmitter, it is very doubtful that changing the direction of the transmitting antenna to right angles with the overhead lines will completely eliminate the trouble.

If, on the contrary, the interference continues when the transmitter is connected to the dummy antenna, radio-frequency energy is being fed directly into the power line by the transmitter, and the station must be inspected to determine the cause.

One of the following reasons for the trouble will usually be found: (1) the r.f. stages are not sufficiently bypassed and/or choked, (2) the antenna coupling system is not performing efficiently, (3) the power transformers have no electrostatic shields; or, if shields are present, they are ungrounded, (4) power lines are running too close to an antenna or r.f. circuits carrying high currents. If none of these causes apply, wave-traps must be installed in the power lines at the transmitter to remove r.f. energy passing back into the lighting system.

The wave-traps used in the power lines at transmitter or receiver must be capable of passing relatively high amperage. The coils

are accordingly wound with heavy wire. Figure 6 lists the specifications for power-line wave-trap coils, while figure 7 illustrates the method of connecting these wave-traps. Observe that these traps are enclosed in a shield box of heavy iron or steel, well grounded.

All-Wave Receivers. Each complete-coverage home receiver is a potential source of annoyance to the transmitting amateur. The novice short-wave broadcast-listener who tunes in an amateur station often considers it to be an interfering signal, and complains accordingly.

Neither selectivity nor image rejection in most of these sets is in any wise comparable to those properties in a communication receiver. The result is that an amateur signal will occupy too much dial space and appear at more than one point, giving rise to interference on adjacent channels and removed channels as well.

If carrier-frequency harmonics are present in the amateur transmission, serious interference will result at the all-wave receiver. The harmonics will, if the carrier frequency has been so unfortunately chosen, fall directly upon a favorite short-wave broadcast station and arouse warranted objection.

The amateur is apt to be blamed, too, for transmissions for which he is not responsible, so great is the public ignorance of short-wave allocations and signals. Owners of all-wave receivers have been quick to ascribe to amateur stations all signals they hear from tape machines and V-wheels, as well as stray tones and heterodyne flutters they hear.

The amateur cannot be held responsible when his carrier is deliberately tuned in on an all-wave receiver. Neither is he accountable for the width of his signal on the receiver dial or for the strength of image repeat points, if it can be proven that the receiver design does not afford good selectivity and image rejection.

If he so desires, the amateur (or the owner of the receiver) might sharpen up the received signal somewhat by shortening the receiving antenna. Set retailers often supply quite a sizable antenna with all-wave receivers, but most of the time these sets perform almost as well with a few feet of inside antenna.

The amateur is accountable for harmonics of his carrier frequency. Such emissions are unlawful in the first place and he must take all steps necessary to their suppression. Practical suggestions for the elimination of harmonics will be found elsewhere in this book (see *Index*).

Superheterodyne Interference

In addition to those types of interference already discussed, there are two more which are common to superhet receivers. The prevalence of these types is of great concern to the amateur, although the responsibility for their existence more properly rests with the broadcast receiver.

The first is the production of broadcast-band images by 160-meter amateur stations. This is possible since the separation between the broadcast band and the 160-meter region is small enough to establish image-frequency relationships.

The mechanism whereby image production is accomplished may be explained in the following manner: When the first detector is set to the frequency of an incoming signal, the high-frequency oscillator is operating on another frequency which differs from the signal by the number of kilocycles in the intermediate frequency. Now, with the setting of these two stages undisturbed, there is another signal which will beat with the high-frequency oscillator to produce an i.f. voltage. This other signal is the so-called image, which is separated from the desired signal by twice the intermediate frequency.

Thus, in a receiver with 175-ke. i.f., tuned to 1000 ke.: the h.f. oscillator is operating on 1175 ke., and a signal on 1350 ke. (1000 ke. plus 2×175 ke.) will beat with this 1175 ke. oscillator frequency to produce the 175-ke. i.f. signal. Similarly, when the same receiver is tuned to 1400 ke., an amateur signal on 1750 ke. can come through. The dial point where any 160-meter signal will produce an image can be determined from the equation:

$$F_{bo} = (F_{am} - 2 \text{ i.f.})$$

Where F_{bo} = receiver dial frequency,
 F_{am} = amateur transmitter frequency, and
 i.f. = receiver intermediate frequency.

If the image appears only a few cycles or kilocycles from a broadcast carrier, heterodyne interference will be present as well. Otherwise, it will be tuned in and out in the manner of a station operating in the broadcast band. Sharpness of tuning will be comparable to that of broadcast stations of the "same power."

The second variety of superhet interference is the result of harmonics of the receiver h.f. oscillator beating with amateur carriers to produce the intermediate frequency of the receiver. The amateur transmitter will always be on a frequency equal to some har-

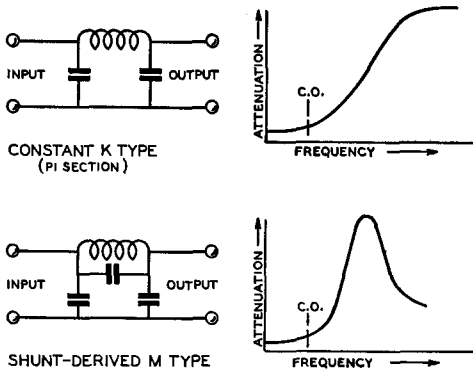

Figure 8.

**TWO TYPES OF LOW PASS FILTERS
AND THE KIND OF ATTENUATION
CURVE OBTAINED WITH EACH.**

The M-derived type has sharper cut-off but not as great attenuation at frequencies two or more octaves above the cut-off frequency.

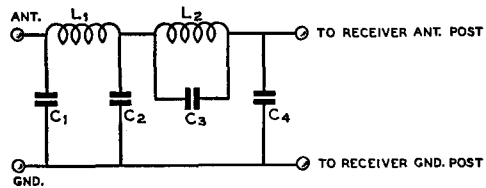

Figure 9.

**COMPOSITE LOW PASS FILTER
POSSESSING ADVANTAGES OF
BOTH K SECTION AND M DERIVED
FILTER.**

This filter is highly effective in reducing broadcast interference from all high frequency stations, and requires no tuning. Constants for 400 ohm terminal impedance and 1600 kc. cut-off are as follows: L_1 , 65 turns no. 22 d.c.c. close wound on 1½ in. dia. form. L_2 , 44 turns ditto, not coupled to L_1 . C_1 , 250 μ fd. fixed mica condenser. C_2 , 400 μ fd. fixed mica condenser. C_3 and C_4 , 150 μ fd. fixed mica condensers. With some receivers better results will be obtained with a 200 ohm carbon resistor inserted between the filter and antenna post on the receiver. With other receivers the effectiveness will be improved with a 600 ohm carbon resistor placed from the antenna post to the ground post on the receiver. The filter should be placed as close to the receiver terminals as possible.

monic of the receiver h.f. oscillator, plus or minus the intermediate frequency.

As an example: When a broadcast superhet with 456-ke. i.f. is tuned to 1000 kc., its high-frequency oscillator operates on 1456 kc. The third harmonic of this oscillator frequency is 4368 kc., which will beat with an amateur phone signal on 3912 kc. to send a signal through the i.f. amplifier. The 3912 kc. signal would be tuned in at the 1000-ke. point on the dial.

Some oscillator harmonics are so related to amateur frequencies that more than one point of interference will occur on the receiver dial. Thus, a 3500-ke. signal may be tuned in at six points on the dial of a 175-ke. broadcast superhet.

Insofar as remedies for image and harmonic superhet interference are concerned, it is well to remember that if the amateur signal did not in the first place reach the input stage of the receiver, the annoyance would not have been created. It is therefore good policy to try to eliminate it by means of a wave-trap. Broadcast superhets are not always the acme of good shielding, however, and the amateur signal is apt to enter the circuit through channels other than the input circuit. If a wave-trap or filter will not cure the trouble, the only alternative will be to attempt to select a transmitter frequency such that neither image nor harmonic interference will be set up on favorite stations in the susceptible receivers. The equation given earlier may be used to determine the proper frequencies.

Low Pass Filters. The greatest drawback of the wave-trap is the fact that it is a single-frequency device; i.e.—it may be set to reject at one time only one frequency (or, at best, an extremely narrow band of frequencies). Each time the frequency of the interfering transmitter is changed, every wave-trap tuned to it must be retuned.

A much more satisfactory device is the *wave filter* which requires no tending. One type, the low pass filter, passes all frequencies below one critical frequency and rejects all higher frequencies. It is this property that makes the device ideal for the task of removing amateur frequencies from broadcast receivers.

A good low pass filter designed for maximum attenuation at some frequency slightly outside the lower edge of the 160-meter band will pass all broadcast carriers, but will reject signals originating in any amateur band. Naturally such a device should be installed only in standard broadcast receivers, never in all-wave sets.

Two types of low pass filters are shown in figure 8. A composite arrangement comprising a section of each type is more effective than either type operating alone. A composite filter composed of one K-section and one shunt-derived M-section ($M=0.6$) is shown in figure 9, and is *highly* recommended.

CHAPTER TWENTY-FIVE

Radio Therapy

Radio-frequency energy can be applied to various parts of the human anatomy in order to produce a localized fever. The increase in temperature is effective for increasing circulation and for stimulating the action of the white corpuscles. The radio frequencies involved in radio therapy normally range from 6 to 16 meters in wavelength, although there has not yet been an accepted standard of frequencies for the treatment of any particular ailment.

The muscular cartilage, fatty and bone tissues all respond differently to applied radio waves. Some of these tissues are dielectrics while others are conductors, yet most of them have an intermediate characteristic, that of leaky dielectric shunted by a capacitance. The radio energy is dissipated in the form of a dielectric loss which increases the temperature of that portion of the body under treatment. This form of treatment is known as *radio therapy*, and the apparatus used for administering the radio-frequency current is called a *diathermy machine*.

A diathermy machine ordinarily consists of an oscillator with a maximum output of from 100 to 400 watts. The load impedance connected across the oscillator varies greatly; this requires special design of the oscillator circuit.

Treatment. The correct application of radio therapy depends upon the ailment and should, therefore, *be under the supervision of a skilled physician*. The diathermy machine usually has a means of controlling the power output. Often it has provision for frequency change in the form of plug-in coils. The radio energy is normally applied by means of a pair of rubber-covered metal electrodes which are placed on opposite sides of the portion of the body under treatment.

Radio therapy is used to kill certain bacteria in the body, much in the same manner as artificially-induced typhoid fever. Be-

cause careless use of radio therapy can and has caused extremely serious damage, self-treatment or the treatment of others by means of a home-built diathermy machine should *never* be attempted except under the supervision of a competent practitioner.

A circuit for an excellent portable diathermy machine is shown in figure 3. This circuit has certain features not found in most commercially-made portable machines. The oscillator circuit proper is a push-pull *Hartley* system in which the grid excitation is more constant than in most u.h.f.

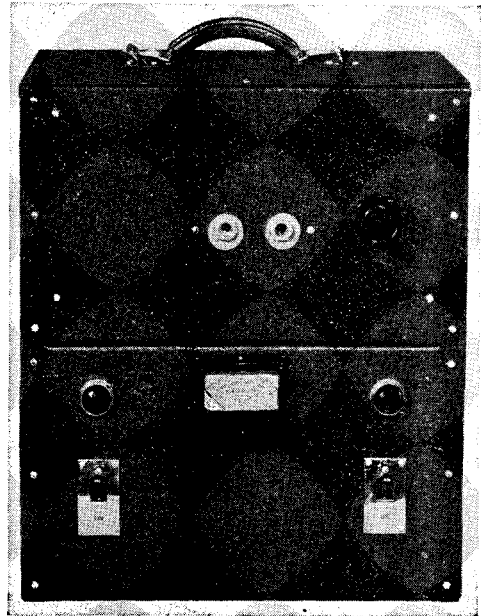

Figure 1.
FRONT VIEW OF 200-WATT PORTABLE
DIATHERMY MACHINE.

This machine is of the type used for home treatment of diseases by radio therapy. It works on 15 meters, has sufficient output for most purposes, and produces a minimum of radio interference.

oscillator circuits for various load impedances.

This machine, illustrated in figures 1 and 2, is similar to the portable machines used by doctors for treating a patient in his own home. Such machines are ordinarily used only with standard type heating pads, no provision being made for electric cautery or "inductotherm" treatment. The latter calls for an insulated conductor to be coiled around the afflicted member or part of the body. The more common method of treatment with applicator pads is just as effective in most cases and usually is more convenient.

Construction. The oscillator and pad circuit are placed on the upper deck and the power supply on the lower deck of a two-deck metal chassis which is fitted with a ventilated cover having a handle. The latter item puts the machine in the category of "portable," as the machine is light enough to be carried by one person.

The oscillator is fixed-tuned to a wavelength of approximately 15 meters by the two plates which constitute C_1 . The pads are resonated by the series condenser C_2 , adjustment of this condenser providing a simple but entirely satisfactory method of regulating the output.

The layout of the power supply components is not critical; they may be arranged in any way which will permit inclusion of all of them on the lower deck. The r.f. components should be laid out approximately as illustrated in figure 2. Both the oscillator coil and the two plates constituting the tank condenser C_1 are supported on two ceramic pillars spaced $4\frac{1}{2}$ inches. These plates, measuring $4\frac{1}{4}$ by $3\frac{1}{2}$ inches high, overlap approximately $3\frac{3}{4}$ inches of their length, and are separated by approximately $\frac{3}{16}$ inch, the exact spacing being finally adjusted until the wavelength of the machine is approximately 15 meters. In no case, however, should the plates be spaced closer than $\frac{1}{8}$ inch; otherwise arcing may occur between them when there is no load on the machine.

The pads are coupled by means of a 3 or 4 turn coil which can be "folded" into the center of the oscillator coil, the latter being wound in two sections separated sufficiently to make room for the coupling coil. The coupling coil is covered with "spaghetti" to prevent shorted turns and prevent high voltage being impressed upon the coupling coil by contact with the oscillator coil.

The oscillator coil consists of 8 turns, with a gap of approximately 1 inch in the cen-

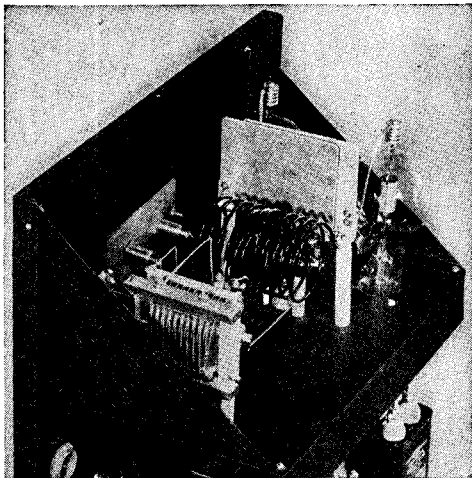

Figure 2.
BACK VIEW OF 200-WATT DIATHERMY
WITH COVER REMOVED.

All power supply components including overload relay are mounted on the lower deck. All r.f. components are mounted on the upper deck.

ter and the whole coil spaced to approximately $3\frac{1}{4}$ inches. Both the oscillator coil and coupling coil are $2\frac{1}{2}$ inches in diameter and wound with no. 10 or no. 8 enamelled wire. The coupling coil is supported from two ceramic pillars, the position of the coil with respect to the oscillator coil being adjusted by bending the wire until the desired degree of loading is obtained. The coupling is increased until the plate current to the oscillator measures approximately 350 ma. when the pads are applied to the body and C_2 is tuned to exact resonance. The coupling need not be touched after this adjustment is once made, all further adjustment of the output being made by means of C_2 .

The condenser C_3 is merely a blocking condenser and has no effect upon the circuit except to protect the patient in the event of structural failure of the pillars supporting the coils or a flash-over between coils. As direct current cannot pass through either C_1 or C_2 , the patient is thus protected from the high voltage plate supply under all contingencies, the rubber insulation on the pads affording further protection.

The grid taps on each tank coil are made exactly the same distance from each side of center. If one tube heats more than the other, the taps have not been made symmetrically. To adjust the taps to their proper position, disconnect the pads from

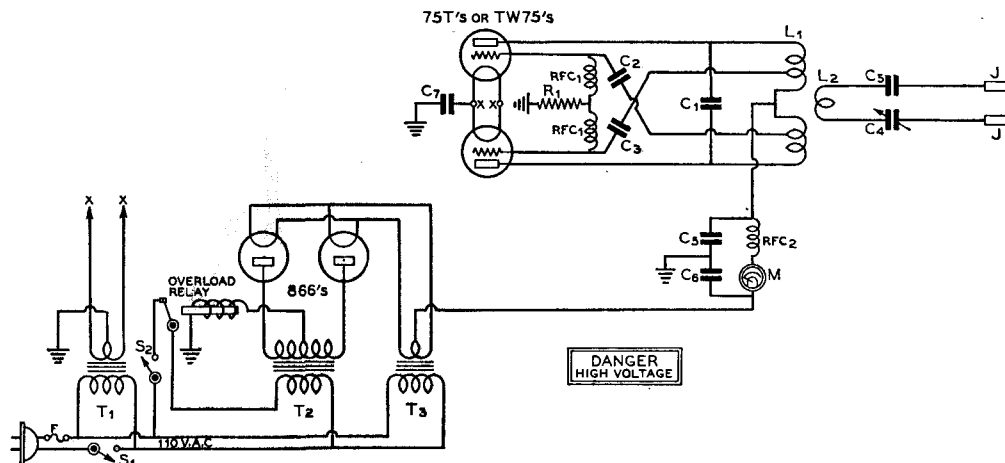

Figure 3.

WIRING DIAGRAM OF THE 200-WATT PORTABLE DIATHERMY.

- | | | | |
|---|---|---|--|
| C ₁ —Two aluminum plates mounted on ceramic pillars (see text) | oil condenser | T ₁ —5¼ v., 13 amp. | 2½" dia., wound with 2 halves spaced 1" and coil spaced to ¾" |
| C ₂ , C ₃ —0.005-μfd. 5000 v. mica | C ₇ —0.01 μfd. 1000 v. mica | T ₂ —1200 v. each side c.t., 350 ma. | L ₂ —3 or 4 turns same wire same dia. inserted between 2 halves of L ₁ . Slip "spaghetti" over wire for insulation |
| C ₄ —100 μμfd., 3000 v. spacing | R ₁ —7500 ohms, 50 watts for 75-T's; 2500 ohms, 50 watts for TW-75's | T ₃ —2½ v. 10 amp., 7500 v. insulation | |
| C ₅ —0.01 μfd. 2500 v. mica | RFC ₁ —High frequency r.f. chokes (see text) | M—0-500 ma. d.c. | |
| C ₆ —0.5 μfd. 2000 v. | RFC ₂ —1 or 2.5 mh. 500 ma. r.f. choke | Overload Relay—Adjustable 300-500 ma. type | |
| | | L ₁ —8 turns no. 8 or no. 10 enameled | |

their circuit, place a 0-150 ma. milliammeter in series with the grounded end of the grid leak R₁, and move the taps out towards the ends of the coil in one inch steps until the grid current reads approximately 65 ma. for 75-T's or 125 ma. for TW-75's. This should be done with the pads removed from the machine (entirely disconnected) and the overload relay shorted out. The correct points will be approximately 1/3 to 1/2 the distance from the center to the ends of the coil. The taps may first be placed approximately 1/4 the distance from the center to the ends and then moved outwardly from there until the specified grid current is obtained.

When the pads are connected and applied to a patient, the grid current will fall off considerably; hence it is necessary to adjust the excitation taps (with the tubes unloaded) for as much grid current as the tubes will stand safely.

A grid meter can be permanently incorporated in this diathermy machine, if desired. It is absolutely necessary, however, only for the initial adjustment.

The grid condensers C₂ and C₃ should be spaced at least one inch from the chassis

and each other. The bakelite in which these condensers are encased is not an especially good dielectric at 15 meters, and the condensers will overheat if they have appreciable capacity to each other or to ground.

The high r.f. voltage at these points also necessitates extra good r.f. chokes for RFC₁. The usual 2½-mh. 125-ma. chokes ordinarily used for grid chokes are not particularly effective, and will usually burn up after a short time. Most any "all-band" choke is none too effective at 15 meters when high r.f. voltages are involved. Hence it is desirable to use at RFC₁ chokes which are especially designed for work at frequencies of this order. Either National R-154-U chokes or Ohmite Z-2 chokes will prove satisfactory, most other chokes having a tendency to burn out the "pie" at the hot end of the choke. The latter effect can be avoided to an extent by using "tapered pie" chokes, with the smaller pies connected to the grids. Use of the grid chokes specified, however, will eliminate all possibility of trouble from burned chokes. Very little r.f. voltage is impressed upon the plate choke RFC₂; hence any type choke will be satisfactory here.

The jacks on the front panel (for the pad cords) should have at least a half inch clearance, and be mounted on Vietron, hard rubber, Mycalex, or Lucite. Ordinary bakelite will break down, as it has a poor power factor at this frequency.

A red ink "warning" marker should be drawn on the scale of the plate meter at the point of 300 ma., to make certain that this value of plate current will not be exceeded. The plate meter is the only essential meter in the machine, although some physicians insist upon an r.f. meter in the pad circuit. Neither plate current nor r.f. output is more than an approximate index of the degree of heating; they are not relied upon except as a relative check when the pads are in any *given position* on a *certain patient*. The actual temperature of that portion of the patient's body under treatment is the only safe barometer of the amount of heating effect being supplied.

The small filter condenser (0.5 μ d.) provides sufficient filtration to prevent the oscillator tubes from going out of oscillation instantaneously 120 times per second. "Hash" on the lower frequencies including the broadcast band will result from such momentary cessation of oscillation. The ripple voltage will still be quite high, with the small filter, but interference on frequencies other than the operating frequency will be eliminated.

It is not advisable to use higher capacity; otherwise the plate voltage will rise to excessive values when the pads are not loaded and the plate current is relatively low. This, in turn, results in excessive grid current. The grid current normally tends to rise anyway when an oscillator is not loaded.

Overload Relay. The overload relay is of the type that can be adjusted to trip anywhere from 300 to 500 ma. After the excitation taps are fixed and the position of the coupling coil is tentatively adjusted, the overload relay can then be set to trip at 325 ma. This will protect the tubes from excessive plate current, and from severe damage that would otherwise result should the tubes go out of oscillation.

If during treatment the relay is continually "kicking out" when adjusted to trip at 325 ma., it indicates that the loading is too heavy, and that the coupling should be backed off a bit.

High-Frequency Interference. If this diathermy machine causes interference to nearby amateurs on the 5-, 10- and 20-meter bands, the cure lies in the installation of a heavy duty *choke-input filter*, consisting of a

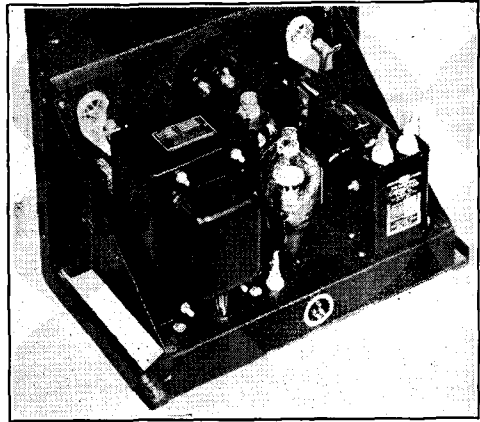

Figure 4.
ILLUSTRATIVE ARRANGEMENTS OF
POWER SUPPLY COMPONENTS.

All power supply components are mounted on the lower deck. In this view, the top deck has been removed in order to show the power supply components.

30-henry 350-ma. swinging choke and a 4- μ d. 2000-volt condenser. This permits a high degree of filtering without sacrificing voltage regulation. The interference will then be confined to a very narrow range of frequencies. If a choke input filter is used, a higher voltage plate transformer will be required (1500 v.).

Rectifier Time Delay. In order to prolong the life of rectifier and oscillator tubes, it is important that they be permitted to warm up for a period of 20 or 30 seconds before plate voltage is applied. Switch SW₂ should never be thrown *on* until switch SW₁ has first been turned on.

If desired, a time delay relay may be used to automatically protect the rectifiers.

Heating Pads. The applicator pads are a standard item, available from most medical supply houses and some electrical and radio supply houses. In ordering pads it is necessary to specify the approximate frequency on which the machine is to operate; otherwise the length of the cords may be too short to permit resonance even with the series condenser entirely meshed. If the cord pads are too *long* they can be cut off 6 inches at a time until they resonate satisfactorily; but if they are too short nothing can be done about it.

Information as to the availability of the heating pads may be obtained by writing the publishers and enclosing a stamped, self-addressed envelope.

CHAPTER TWENTY-SIX

Radio Mathematics and Calculations

Into this chapter have been grouped various charts and methods of computation for types of calculation which will be found useful in radio work. The decibel, logarithms, calculation of gain and loss, calculation of inductance, and determination of frequency of resonance will be discussed.

The Decibel

The decibel unit as used in radio engineering and virtually universal in all power and energy measurements is actually a unit of amplification expressed as a common logarithm of a power or energy ratio. One decibel is 1/10th of a bel. One bel or 10 decibels indicate an amplification by 10, the common logarithm of 10 being 1. Similarly, 2 bels or 20 db mean amplification by 100; 30 db mean amplification by 1,000, and so on. The power ratio for one decibel is expressed as

$$\frac{P_1}{P_2} = 10^{0.1} \quad (1)$$

where P_1 is the power input; P_2 , the power output. The number of decibels represents a power gain or loss, depending upon whether the relation P_1/P_2 is greater or less than 1.

Expressions for various power ratios are now commonly employed in communication engineering at audio and at radio frequencies. To express a ratio between any two amounts of power, it is convenient to use a logarithmic scale. A table of logarithms facilitates making conversions in positive or negative directions between the number of decibels and the corresponding power, voltage and current ratios.

Logarithmic Table. The table of logarithms presented here does not differ essentially from any other similar table except

that no proportional parts are given and the figures are stated to only three decimal places; this arrangement does not permit great accuracy but has been found to be satisfactory for all practical radio purposes. A complete exposition on logarithms is outside the scope of this HANDBOOK; however, the very essentials together with the practical use of the tables and their application to decibels are given herewith. The following discussion is not concerned with the study of logarithms other than their direct employment to decibels.

The logarithm of a number usually consists of two parts: a whole number called the *characteristic* and a decimal called the *mantissa*. The characteristic is the integral portion to the *left* of the decimal point (see examples below), and the mantissa is the value placed to the *right*. The mantissa is all that appears in the table of logarithms.

In the logarithm, the mantissa is independent of the position of the decimal point, while the characteristic is dependent only on the position of the number with the relation to the decimal point. Thus, in the following examples:

	Number	Logarithm
(a)	4021.	= 3.604
(b)	402.1	= 2.604
(c)	40.21	= 1.604
(d)	4.021	= 0.604
(e)	.4021	= -1.604
(f)	.04021	= -2.604

it will be seen that the characteristic is equal, algebraically, to the number of digits *minus one* to the left of the decimal point.

In (a) the characteristic is 3, in (b) 2, in (d) 0, in (e) -1, in (f) -2. The following should be remembered: (1) that for a number greater than 1, the characteristic

is *one less* than the number of digits to the left of the decimal point; (2) that for a number wholly a decimal, the characteristic is *negative* and is numerically *one greater* than the number of ciphers immediately following the decimal point. Notice (e) and (f) in the above examples.

To find a common logarithm of any number, proceed as directed herewith. Suppose the number to be 5576. First, determine the characteristic. An inspection will show that this number will be three. The figure is placed to the *left* of a decimal point. The mantissa is now found by referring to the logarithm table. Proceed selecting the first two numbers which are 55, then glance down the N column until coming to these figures.

Advance to the right until coming in line with the column headed 7; the number will be 746. (Note that the column headed 7 corresponds to the *third* figure in the number 5576). Place the mantissa 746 to the *right* of the decimal point making the number now read 3.746. This is the logarithm of 5576. *Important*: do not consider the last figure, 6, in the number 5576 when looking for the mantissa in the accompanying three-place tables; in fact, disregard all digits beyond the first three when determining the mantissa. (*Interpolation*, to find the true log of 5576, cannot be accurately done from 3-place values.) However, be doubly sure to include *all* figures when ascertaining the magnitude of the *characteristic*.

THREE-PLACE LOGARITHMS										
N	0	1	2	3	4	5	6	7	8	9
00	000	000	000	000	000	000	000	000	000	000
01	000	004	008	012	017	021	025	029	033	037
11	041	045	049	053	056	060	064	068	071	075
12	079	082	086	089	093	096	100	103	107	110
13	113	117	120	123	127	130	133	136	139	143
14	146	149	152	155	158	161	164	167	170	173
15	176	179	181	184	187	190	193	195	198	201
16	204	206	209	212	214	217	220	222	225	227
17	230	233	235	238	240	243	245	248	250	252
18	255	257	260	262	264	267	269	271	274	276
19	278	281	283	285	287	290	292	294	296	298
20	301	303	305	307	309	311	313	316	318	320
21	322	324	326	328	330	332	334	336	338	340
22	342	344	346	348	350	352	354	356	358	359
23	361	363	365	367	368	371	372	374	376	378
24	380	382	383	385	387	389	390	392	394	396
25	397	399	401	403	404	406	408	409	411	413
26	415	416	418	420	421	423	424	426	428	429
27	431	433	434	436	437	439	440	442	444	445
28	447	448	450	451	453	454	456	457	459	460
29	462	463	465	466	468	469	471	472	474	475
30	477	478	480	481	482	484	485	487	488	490
31	491	492	494	495	496	498	499	501	502	503
32	505	506	507	509	510	511	513	514	515	517
33	518	519	521	522	523	525	526	527	528	530
34	531	532	534	535	536	537	539	540	541	542
35	544	545	546	547	549	550	551	552	553	555
36	556	557	558	559	561	562	563	564	565	567
37	568	569	570	571	572	574	575	576	577	578
38	579	580	582	583	584	585	586	587	588	589
39	591	592	593	594	595	596	597	598	599	601
40	502	603	604	605	606	607	608	609	610	611
41	612	613	614	616	617	618	619	620	621	622
42	623	624	625	626	627	628	629	630	631	632
43	633	634	635	636	637	638	639	640	641	642
44	643	644	645	646	647	648	649	650	651	652
45	653	654	655	656	657	658	659	659	660	661
46	662	663	664	665	666	667	668	669	670	671
47	672	673	673	674	675	676	677	678	679	680
48	681	682	683	683	684	685	686	686	687	688
49	690	691	692	692	693	694	695	696	697	698
50	699	699	700	701	702	703	704	705	705	706
51	707	708	709	710	711	712	713	713	715	715
52	716	716	717	718	719	720	721	722	722	723
53	724	725	725	726	727	728	729	730	730	731
54	732	733	734	734	735	736	737	738	738	739
N	0	1	2	3	4	5	6	7	8	9

THREE-PLACE LOGARITHMS										
N	0	1	2	3	4	5	6	7	8	9
55	740	741	741	742	743	744	745	746	747	747
56	748	749	749	750	751	752	752	753	754	755
57	755	756	757	758	758	759	760	761	761	762
58	763	764	764	765	766	767	767	768	769	770
59	770	771	772	773	773	774	775	776	776	777
60	778	778	779	780	781	781	782	783	783	784
61	785	786	786	787	788	788	789	790	791	791
62	792	793	793	794	795	795	796	797	798	798
63	799	800	800	801	802	802	803	804	804	805
64	806	806	807	808	809	810	810	811	811	812
65	813	813	814	814	815	816	816	817	818	818
66	819	820	820	821	822	822	823	824	824	825
67	826	826	827	828	828	829	829	830	831	831
68	832	833	833	834	835	835	836	837	837	838
69	838	839	840	840	841	842	842	843	843	844
70	845	845	846	847	848	848	849	849	850	850
71	851	851	852	853	853	854	854	855	856	856
72	857	857	858	859	859	860	860	861	861	862
73	863	863	864	865	865	866	866	867	868	868
74	869	869	870	871	872	872	873	873	874	874
75	875	875	876	876	877	877	878	879	879	880
76	880	881	882	882	883	883	884	884	885	885
77	886	887	887	888	888	889	889	890	891	891
78	892	892	893	893	894	894	895	896	896	897
79	897	898	898	899	899	900	900	901	902	902
80	903	903	904	904	905	905	906	906	907	907
81	908	909	909	910	910	911	911	912	912	913
82	913	914	914	915	915	916	917	917	918	918
83	919	919	920	920	921	921	922	922	923	923
84	924	924	925	925	926	926	927	927	928	928
85	929	929	930	930	931	932	932	933	933	934
86	934	935	935	936	936	937	937	938	938	939
87	939	940	940	941	941	942	942	943	943	944
88	944	945	945	946	946	947	947	948	948	948
89	949	949	950	950	951	951	952	952	953	953
90	954	954	955	955	956	956	957	957	958	958
91	959	959	960	960	960	961	961	962	962	963
92	963	964	964	965	965	966	966	967	967	968
93	968	968	969	969	970	970	971	971	972	972
94	973	973	974	974	975	975	976	976	977	977
95	977	978	978	979	979	980	980	980	981	981
96	982	982	983	983	984	984	985	985	985	986
97	986	987	987	988	988	989	989	989	990	990
98	991	991	992	992	993	993	993	994	994	995
99	995	996	996	996	997	997	998	998	999	999
N	0	1	2	3	4	5	6	7	8	9

DB	POWER RATIO
0	1.00
1	1.26
2	1.58
3	2.00
4	2.51
5	3.16
6	3.98
7	5.01
8	6.31
9	7.94
10	10.00
20	100
30	1,000
40	10,000
50	100,000
60	1,000,000
70	10,000,000
80	100,000,000

Practical application of logarithms to decibels will follow. Other methods of using logarithms will be discussed as the subject develops.

Power Levels. In the design of radio devices and amplifying equipment, the standard power level of six milliwatts (.006 w.) is the arbitrary reference level of zero decibels. All power levels above the reference level are designated as plus quantities, and below as minus. The figure is always prefixed by a plus (+) or minus (-) sign indicating the direction in which the quantity is to be read.

Power to Decibels. The power output (watts) of any amplifier may be converted into decibels by the following formula, assuming that the input and output impedances are equal:

$$N_{db} = 10 \text{ Log}_{10} \frac{P_1}{P_2} \quad (2)$$

where N_{db} is the desired power level in decibels; P_1 , the output of the amplifier, and P_2 , the reference level of 6 milliwatts. The subnumeral, 10, affixed to the logarithm indicates that the log is to be extracted from a log table using 10 as the base, such as the one given here.

Substitute values for the letters in the above formula as in the following:

An amplifier using 2A5 tube should be able to deliver an undistorted output of three watts. How much is this in decibels?

Solution by formula (2)

$$\frac{P_1}{P_2} = \frac{3}{.006} = 500$$

$10 \times \text{Log } 500 = 10 \times 2.69$
therefore $10 \times 2.69 = 26.9$ decibels.

Substituting other values for those shown allows any output power to be converted into decibels *provided* that the decibel equivalent is *above* the zero reference level or the power is *not less* than 6 milliwatts.

To solve almost all problems to which the solution will be given in minus decibels, an understanding of *algebraic addition is required*. To add algebraically, it is necessary to observe the plus and minus signs of expressions. (Do not confuse these signs with decibels.) In the succeeding illustrations notice that the result is obtained sometimes by addition and at other times by subtraction.

(a)	(b)	(c)	(d)
+2	-4	+4	+4
-4	-2	-2	+2
—	—	—	—
-2	-6	+2	+6

The terms used in (c) are those that apply to decibel calculations.

When the solution to a problem involving logarithms will be in minus decibels (when the power level under consideration is less than 6 milliwatts), note particularly that the characteristic of this logarithm will be prefixed by a minus sign (-). Note also that this sign affects *only* the characteristic; the mantissa remains positive. The mantissa *always* remains positive, regardless of whether the solution of the problem results in a positive or a negative characteristic.

A prefix -1 to a logarithm means that the first significant figure of the number which it represents will be the *first* place to the *right* of the decimal point; -2 means that it will occupy the second place to the right while the first will be filled by a cipher; -3, the third place with two ciphers filling the first and second, and so on.

To multiply a logarithm with a *minus* characteristic and a positive mantissa by another number, each part must be considered separately, multiplied by the number (10 or 20 for decibel calculations), and then the products added algebraically. Thus, in the following illustration:

A preamplifier for a microphone is feeding 1.5 milliwatts into the line going to the regular speech amplifier. What is this power level expressed in decibels? Solution by formula (2):

$$\frac{P_1}{P_2} = \frac{.0015}{.006} = .25$$

Log .25 = -1.397 (from table). Therefore, $10 \times -1.397 = (10 \times -1 = -10) + (10 \times .397 = 3.97)$; adding the products *algebraically* gives -6.03 db.

By substituting other values for those in the above example, any output power *below* 6 milliwatts (zero reference level) can be converted into decibels.

Determining Db Gain or Loss. In using amplifiers, it is a prime requisite to be able to indicate gain or loss in *decibels*. To determine the gain or loss in db employ the following formula:

$$(\text{gain}) N_{db} = 10 \text{ Log } \frac{P_o}{P_i} \quad (3)$$

$$(\text{loss}) N_{db} = 10 \text{ Log } \frac{P_i}{P_o} \quad (4)$$

where N_{db} is the number of db gained or lost; P_i , the input power, and P_o , the output power.

Applying, for example, formula (3): Suppose that an intermediate amplifier is being driven by an input power of 0.2 watt and after amplification, the output is found to be 6 watts.

$$\frac{P_o}{P_i} = \frac{6}{.2} = 30$$

$$\text{Log } 30 = 1.48$$

Therefore $10 \times 1.48 = 14.8$ db power gain.

Amplifier Ratings. The technical specifications or rating on power amplifiers should contain the following information: the overall gain in decibels, the power output in watts, the value of the input and output impedances, the input signal level in db, the input signal voltage and the power output level in decibels.

If the specifications on an amplifier include only the input and output signal levels in db, it then is necessary to calculate how much these values represent in power. The methods employed to determine power levels are not similar to those used in previous calculations. Caution should, therefore, be taken in reading the following explanations, with particular care and attention being paid to the minor arithmetical operations.

The Antilogarithm. To determine a power level from some given decibel value, it is necessary to invert the logarithmic process formerly employed in converting power to decibels. Here, instead of looking for the log of a number, it is now necessary to find

the *antilogarithm* or number corresponding to a given logarithm.

In deriving a number corresponding to a logarithm, it is important that these simple rules be committed to memory: (1) that the figures that form the original number from a corresponding logarithm depend entirely upon the mantissa or decimal part of the log (2) that the characteristic serves only to indicate where to place the decimal point of the original number, (3) that, if the original number was a whole number, the decimal point would be placed to the extreme right.

The procedure of finding the number corresponding to a logarithm is explained by the following: Suppose the logarithm to be 3.574. First search in the table under any column from 0 to 9 for the numbers of the mantissa 574. If the exact number cannot be found, look for the next *lowest* figure which is nearest to, but less than, the given mantissa. After the mantissa has been located, simply glance immediately to the left to the N column and there will be read the number, 37. This number comprises the first two figures of the number corresponding to the antilog. The third figure of the number will appear at the head of the column in which the mantissa was found. In this instance the number heading the column will be 5. If the figures have been arranged as they have been found, the number will now be 375.

Now, since the characteristic is 3, there must be four figures to the *left* of the decimal point; therefore by annexing a cipher, the number becomes 3750; this is the number that corresponds to the logarithm 3.574. If the characteristic were 2 instead of 3, the number would be 375. If the logarithm were -3.574 or -1.574, the antilogs or corresponding numbers would be .00375 and .375 respectively. After a little experience, a person can obtain the number corresponding to a logarithm in a very few seconds.

Converting Decibels to Power. It is always convenient to be able to convert a decibel value to a power equivalent. The formula used for converting decibels into watts is similar in many respects to equation (2), the only difference being that the factor P_i corresponding to the power level is not known. Usually the formula for converting decibels into power is written as:

$$N_{db} = 10 \text{ Log } \frac{P_i}{.006} \quad (5)$$

It is difficult to derive the solution to the above equation because of the expression be-

CONVERSION CHART: POWER TO DECIBELS

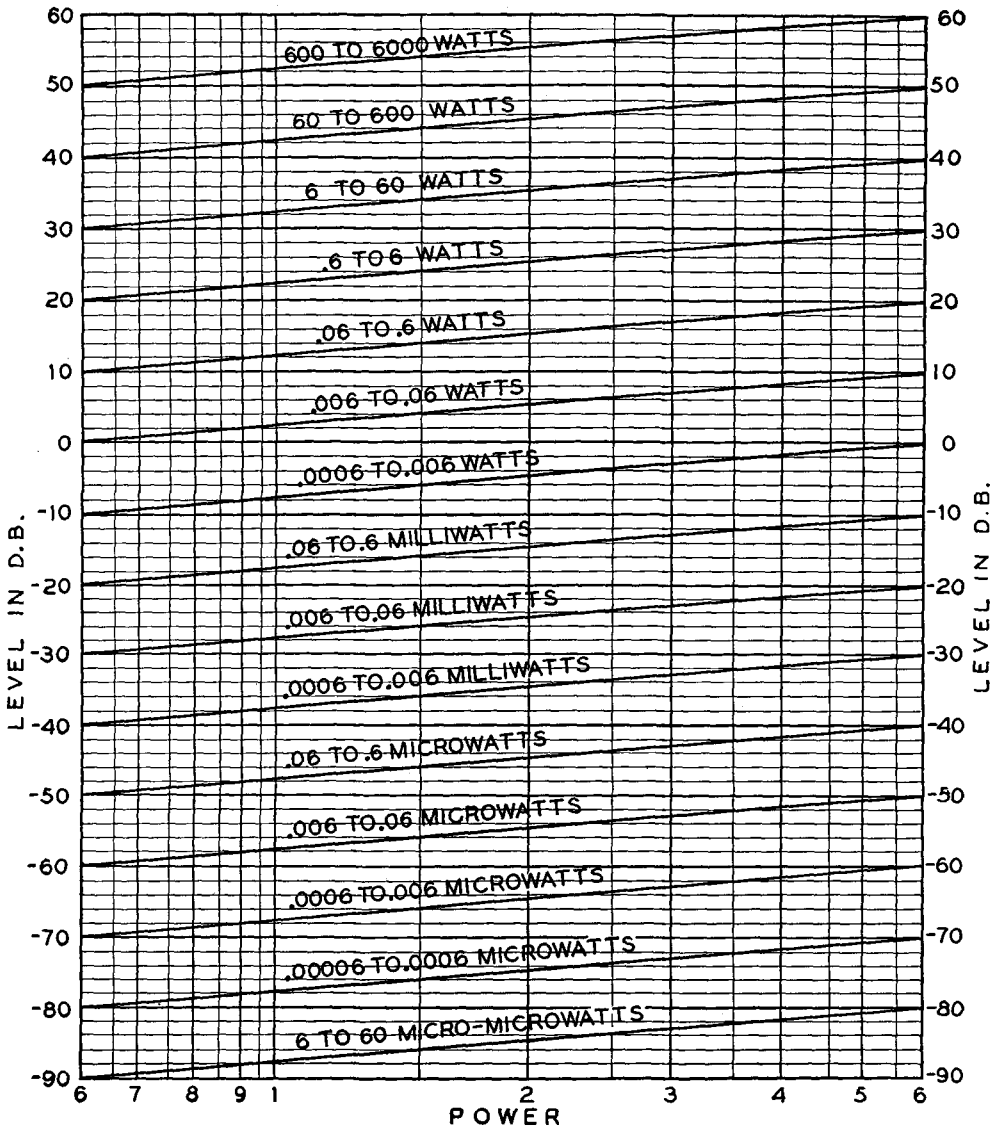

Power levels between 6 micromicrowatts and 6000 watts may be referred to corresponding decibel levels between -90 and 60 db, and vice versa, by means of the above chart. Fifteen ranges are provided. Each curve begins at the same point where the preceding one ends, enabling uninterrupted coverage of the wide db and power ranges with condensed chart. For example; the lowermost curve ends at -80 db or 60 micromicrowatts and the next range starts at the same level. Zero db is taken as 6 milliwatts (.006 watt).

ing written in the reverse. However, by re-arranging the various factors, the expression can be simplified to permit easy visualization; thus:

$$P = .006 \times \text{antilog} \frac{N_{db}}{10} \quad (6)$$

where P is the desired power level; .006, the reference level in milliwatts; N_{db} , the decibels to be converted, and 10, the divisor.

To determine the power level, P, from a decibel equivalent, simply divide the decibel value by 10, then take the number comprising the antilog and multiply it by .006; the product gives the power level of the decibel value.

NOTE: In all problems dealing with the conversion of *minus* decibels to power, it often happens that the decibel value $-N_{db}$, is not always equally divisible by 10. When this is the case, the numerator in the factor $-N_{db}/10$ must be made evenly divisible by the denominator in order to derive the proper power ratio. Note that the value $-N_{db}$ is negative; hence, when dividing by 10, the negative signs must be observed and the quotient labeled accordingly.

To make the numerator in the value $-N_{db}$ equally divisible by 10, proceed as follows: Assume $-N_{db}$ to be the value -38; hence, to make this figure equally divisible by 10, we must add a -2 to it, and, since we have added a negative 2 to it, we must also add a positive 2 to make the net result the same.

Our decibel value now stands, $-40+2$. Dividing both of these figures by 10 (as in equation 6), we have -4 and a plus 0.2. Putting the two of them together, we have -4.2 as our resulting logarithm, with the negative characteristic and positive mantissa required to indicate a number smaller than one.

While the above discussion applies strictly to negative values, the following examples will clearly show the technique to be followed for almost all practical problems.

(a) The output level of a popular velocity ribbon microphone is rated at -74 db. What is the equivalent in milliwatts?

Solution by equation (6)

$$\frac{-N_{db}}{10} = \frac{-74}{10} \quad (\text{not equally divisible by } 10)$$

Routine:

$$\begin{array}{r} -74 \\ - 6 \\ \hline -80 \end{array} \qquad \begin{array}{r} \\ \\ +6 \\ +6 \end{array}$$

$$\frac{-N_{db}}{10} = \frac{-80 + 6}{10} = -8.6$$

Antilog $-8.6 = .00000004$
 $.006 \times .00000004 = .0000000024$ watt or 240 micro-microwatts.

(b) This example differs somewhat from that of the foregoing one in that the mantissas are added differently. A low-powered amplifier has an input signal level of -17.3 db. How many milliwatts does this value represent?

Solution by equation (6)

Routine:

$$\begin{array}{r} -17.3 \\ - 2.7 \\ \hline -20.0 \\ -N_{db} \end{array} \qquad \begin{array}{r} +2.7 \\ +2.7 \\ +2.7 \end{array}$$

$$\frac{-N_{db}}{10} = \frac{-20 + 2.7}{10} = -2.27$$

Antilog $-2.27 = .0186$
 $.006 \times .0186 = .0001116$ watt or .1116 milliwatts.

Voltage Amplifiers. When plans are being drafted contemplating the design of power amplifiers, it is essential that the following data be determined: first, the input and output signal levels to be used; second, the size of the power tubes that will adequately deliver sufficient undistorted output; third, the input signal voltage that must be applied to the amplifier to deliver the desired output. This last requirement is the most important in the design of voltage amplifiers.

The voltage step-up in a transformer-coupled amplifier depends chiefly upon the μ of the tubes and the turns ratio of the interstage coupling transformers. The step-up value in any amplifier is calculated by multiplying the step-up factor of each voltage amplifying or step-up device. Thus, for example, if an amplifier were designed having an output transformer with a ratio of 3:1 coupled to a tube having a μ of 7, the voltage step-up would be approximately 3 times 7 or 21. It is seldom that the total product will be exactly the figure derived because it is not possible to realize amplification equal to the full μ of the tube.

Decibel-Voltage Ratios. From the voltage gain in an amplifier, it is possible to calculate the input and output signal levels and at the same time be able to determine at what level the input signal must be in order to obtain the desired output. By converting voltage ratios into decibels, power levels can

REACTANCE-FREQUENCY CHART.

See text for applications and instructions for use.

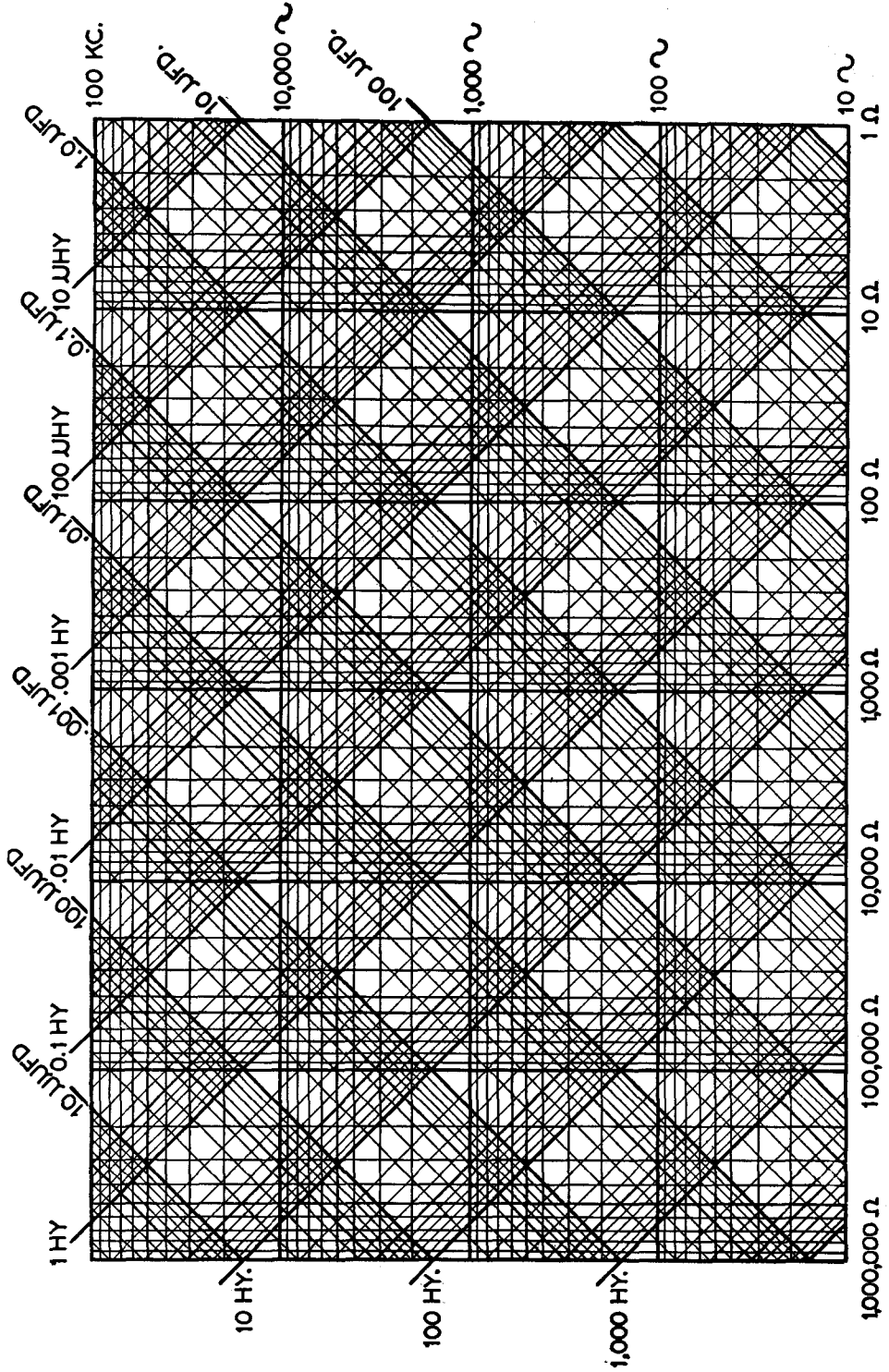

be determined. Hence, to find the gain in db when the input and output voltages are known, the following expression is used:

$$(\text{gain}) N_{ab} = 20 \text{ Log } \frac{E_1}{E_2} \quad (7)$$

where E_1 , is the output voltage, and E_2 , the input voltage.

Employing the above equation in a practical problem, note the logarithm is multiplied by 20 instead of by 10 as in previous examples. For instance:

A certain one-stage amplifier consists of the following parts: 1 input transformer, ratio 2:1, and 1 output tube having a μ of 95. Determine the gain in decibels with an input voltage of 1 volt.

Solution by equation (7)

$$2 \times 95 = 190 \text{ voltage gain}$$

$$\text{therefore, } \frac{E_1}{E_2} = \frac{190}{1} = 190$$

$$\text{Log } 190 = 2.278$$

$$20 \times 2.278 = 45.56 \text{ decibels gain.}$$

To reverse the above and convert decibels to voltage ratios, use the following expression:

$$E (\text{gain}) = \text{antilog } \frac{N_{ab}}{20} \quad (8)$$

where E is the voltage gain (power ratio); N_{ab} , the decibels, and 20, the divisor.

To find the gain, simply divide the decibels by 20, then extract the antilog from the quotient; the result gives the voltage ratio.

Input Voltages. In designing power amplifiers, it is paramount to have *exact* knowledge of the magnitude of the input signal voltage necessary to drive the output power tubes to maximum undistorted output.

To determine the required input voltage, take the *peak voltage* necessary to drive the grid of the last class-A amplifier tube to maximum output and divide this figure by the total overall gain *preceding this stage*.

Computing Specifications. From the preceding explanations the following data can be computed with a very high degree of accuracy:

- (1) Voltage amplification
- (2) Overall gain in db
- (3) Output signal level in db
- (4) Input signal level in db
- (5) Input signal level in watts
- (6) Input signal voltage.

Push-Pull Amplifiers. To double the output of any cascade amplifier, it is only necessary to connect in push-pull the last amplifying stage and replace the interstage and output transformers with push-pull types.

To determine the voltage gain (voltage ratio) of a push-pull amplifier, take the ratio of one *half* of the secondary winding of the push-pull transformer and multiply it by the μ of one of the output tubes in the push-pull stage; the product, *when doubled*, will be the voltage amplification or step-up.

Acoustically (that is, from the loudspeaker standpoint) it takes approximately three db before any change in the volume of sound is noted. This is because the intensity of sound as heard by the ear varies logarithmically with the acoustic power. For practical purposes it is only necessary to remember that if two sounds differ in physical intensity by less than three db, they sound practically alike.

Preamplifiers. Preamplifiers are employed to raise low input signal levels up to some required input level of another intermediate or succeeding amplifier. For example: if an amplifier was designed to operate at an input level of -30 db and instead a considerably lower input level were used, a preamplifier would then have to be designed to bring the low input signal up to the rated input-signal level of -30 db to obtain the full undistorted output from the power tubes in the main amplifier. The amount of gain necessary to raise a low input-signal level up to another level may be determined by the following equation:

$$E (\text{gain}) = \text{antilog } \frac{N_{ab1} - N_{ab2}}{20} \quad (9)$$

where E is the voltage step-up or gain; N_{ab1} , the input signal level of the preamplifier or the new input signal level; N_{ab2} , the input signal level to the intermediate amplifier, and 20, the divisor.

Reactance Calculations

In audio frequency calculations an accuracy to better than a few per cent is seldom required, and when dealing with calculations involving inductance, capacitance, resonant frequency, etc., it is much simpler to make use of a reactance-frequency chart such as that on page 508 rather than to wrestle with a combination of unwieldy formulas. From this chart it is possible to determine the reactance of a condenser or coil if the capacitance or inductance is known, and vice versa.

COIL CALCULATOR NOMOGRAPH.

For single layer solenoid coils, any wire size. See text for instructions.

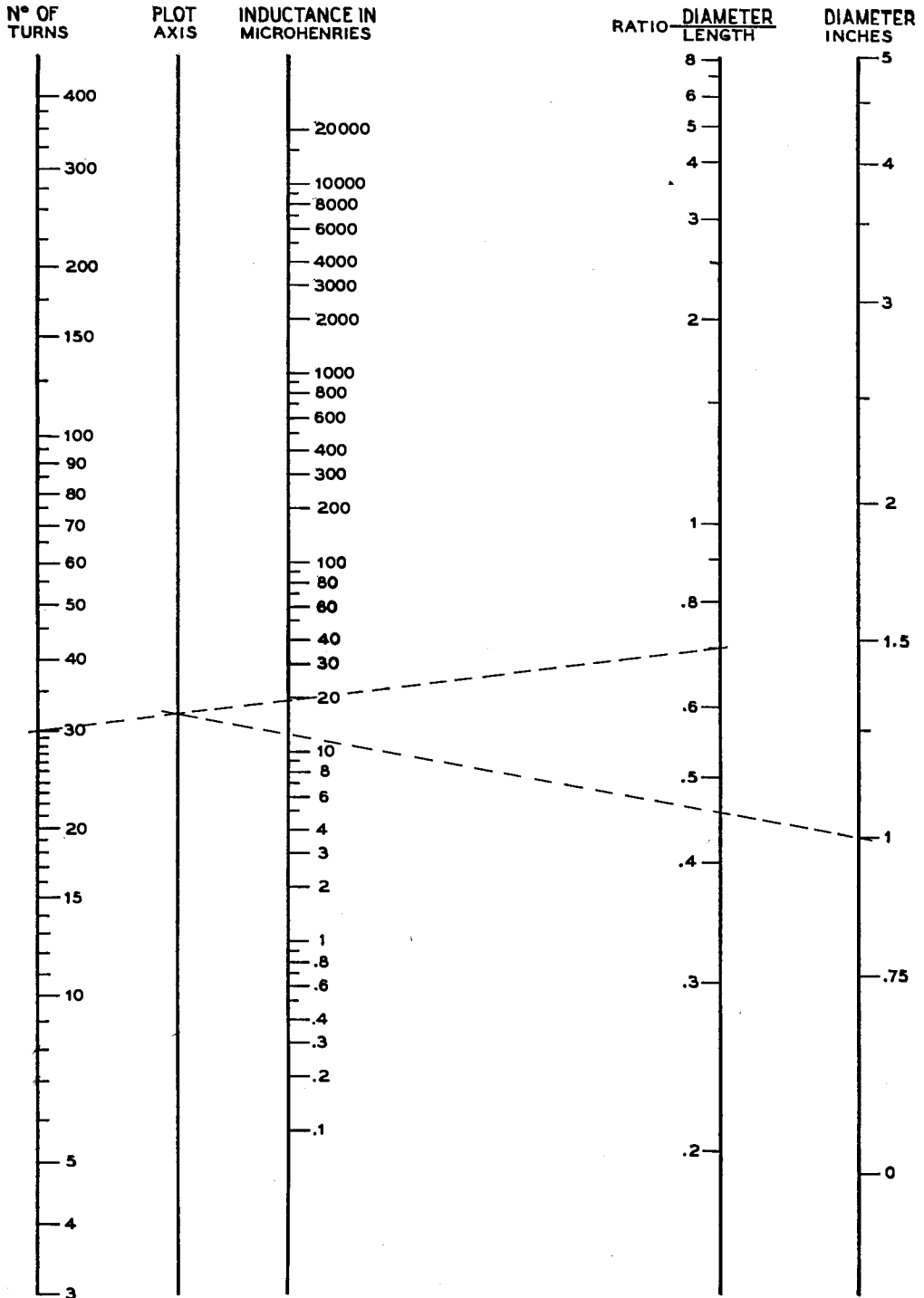

REACTANCE-FREQUENCY CHART FOR R. F.

This chart is used in conjunction with the nomograph on opposite page for radio frequency tank coil computations.

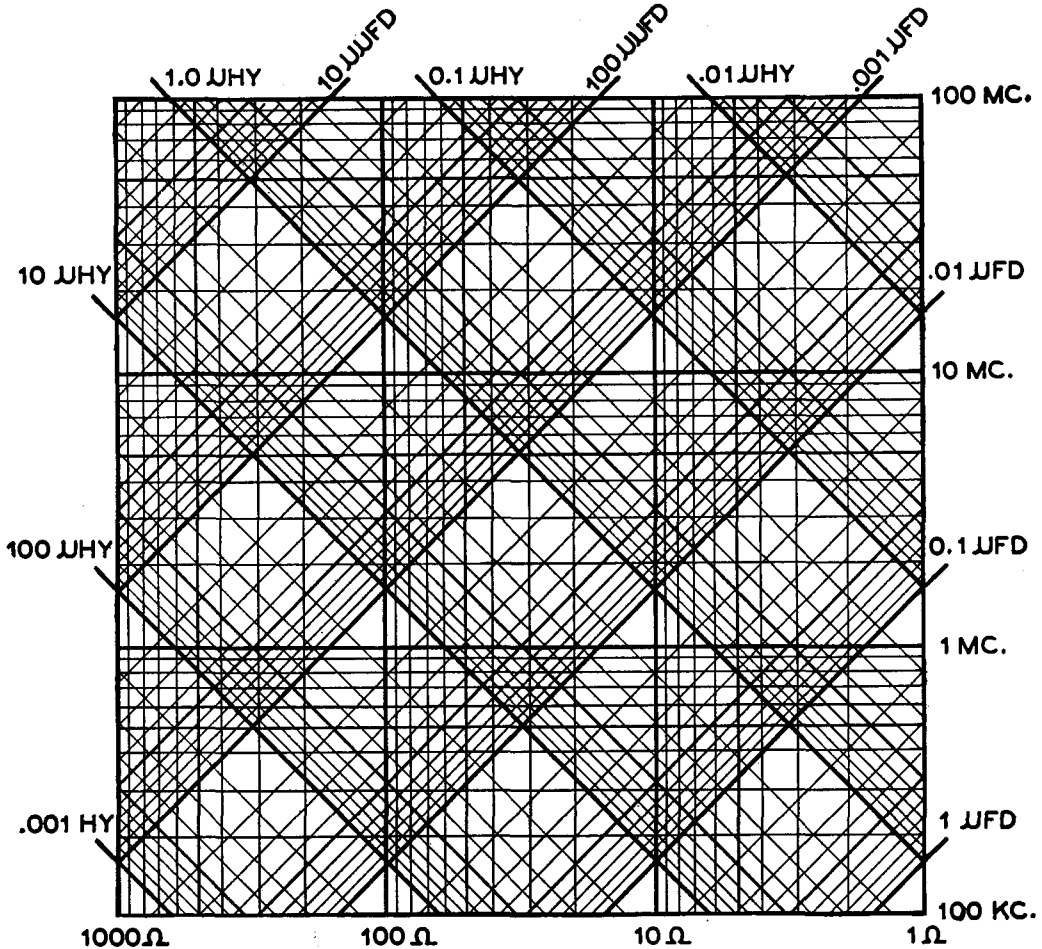

It follows from this that resonance calculations can be made directly from the chart, because resonance simply means that the inductive and capacitive reactances are equal. The capacity required to resonate with a given inductance, or the inductance required to resonate with a given capacity can be taken directly from the chart.

While the chart may look somewhat formidable to one not familiar with charts of this type, its application is really quite simple, and can be learned in a few seconds. The following example should clarify its interpretation.

For instance, following the lines to their intersection we see that 0.1 hy. and 0.1 μ fd.

intersect at approximately 1,500 cycles and 1000 ohms. Thus the reactance of either the coil or condenser taken alone is about 1000 ohms, and the resonant frequency about 1,500 cycles.

To find the reactance of 0.1 hy. at say 10,000 cycles, simply follow the inductance line diagonally up towards the upper left till it intersects the horizontal 10,000 kc. line. Following vertically downward from the point of intersection we see that the reactance at this frequency is about 6000 ohms.

To facilitate use of the chart and to avoid errors, simply keep the following in mind: The vertical lines indicate reactance in ohms, the horizontal lines always indicate the fre-

quency, the diagonal lines sloping to the lower right represent inductance, and the diagonal lines sloping toward the lower left indicate capacitance. Also remember that the scale is *logarithmic*. For instance, the next horizontal line above 1000 cycles is 2000 cycles. Note that there are 9, not 10, divisions between the heavy lines. This also should be kept in mind when interpolating between lines when best possible accuracy is desired; halfway between the line representing 200 cycles and the line representing 300 cycles is *not* 250 cycles, but approximately 230 cycles. The 250 cycle point is approximately 0.7 of the way between the 200 cycle line and the 300 cycle line, rather than halfway between.

Use of the chart need not be limited by the physical boundaries of the chart. For instance, the 10 $\mu\mu\text{fd.}$ line can be extended to find where it intersects the 100 hy. line, the resonant frequency being determined by projecting the intersection horizontally back on to the chart. To determine the reactance, the logarithmic ohms scale must be extended.

R. F. Tank Circuit Calculations. When winding coils for use in radio receivers and transmitters it is desirable to be able to determine in advance the full coil specifications for a given frequency. Likewise it often is desired to determine how much capacity is required to resonate a given coil so that a suitable condenser can be used.

Fortunately, extreme accuracy is not required except where fixed capacitors are used across the tank coil with no provision for trimming the tank to resonance. Thus, even though it may be necessary to estimate the stray circuit capacity present in shunt with the tank capacity and to take for granted the likelihood of a small error when using a chart instead of the formula upon which the chart was based, the results will be sufficiently accurate in most cases, and in any case give a reasonably close point from which to start "pruning."

The inductance required to resonate with a certain capacitance is given in the chart on

page 511. The data previously given on using the audio frequency reactance chart also apply to the r.f. chart. By means of the r.f. chart the inductance of the coil can be determined, or the capacitance determined if the inductance is known. When making calculations, be sure to allow for stray circuit capacity, such as tube interelectrode capacity, wiring, sockets, etc. This will normally run from 5 to 25 $\mu\mu\text{fd.}$, depending upon the components and circuit.

To convert the inductance in microhenries to physical dimensions of the coil, or vice versa, the nomograph chart on page 510 is used. A pin and a straightedge are required. The inductance of a coil is found as follows:

The straightedge is placed from the correct point on the turns column to the correct point on the diameter-to-length ratio column, the latter simply being the diameter divided by the length. Place the pin at the point on the plot axis column where the straightedge crosses it. From this point lay the straightedge to the correct point on the diameter column. The point where the straightedge intersects the inductance column will give the inductance of the coil.

From the chart we see that a 30 turn coil having a diameter-to-length ratio of 0.7 and a diameter of 1 inch has an inductance of approximately 12 microhenries. Likewise any one of the four factors may be determined if the other three are known. For instance, to determine the number of turns when the desired inductance, the D/L ratio, and the diameter are known, simply work backwards from the example given. In all cases remember that the straightedge reads either turns and D/L ratio *or* it reads inductance and diameter. It can read no other combination.

The actual wire size has negligible effect upon the calculations for commonly used wire sizes (no. 10 to no. 30). The number of turns of insulated wire that can be wound per inch (solid) will be found in the wire table on page 306.

APPENDIX

Radio Laws

Pertinent Extracts from the Communications Act of 1934, as Amended; International Radiotelegraph Conference, Madrid, 1932; International Radio Regulations (Cairo Revision, 1938).

Extracts of the Communications Act of 1934, as amended.

Section 1. For the purpose of regulating interstate and foreign commerce in communication by wire and radio so as to make available, so far as possible, to all the people of the United States a rapid, efficient, Nationwide, and world-wide wire and radio communication service with adequate facilities at reasonable charges, for the purpose of the national defense, for the purpose of promoting safety of life and property through the use of wire and radio communication, and for the purpose of securing a more effective execution of this policy by centralizing authority heretofore granted by law to several agencies and by granting additional authority with respect to interstate and foreign commerce in wire and radio communication, there is hereby created a Commission to be known as the "Federal Communications Commission," which shall be constituted as hereinafter provided and which shall execute and enforce the provisions of this act.

Sec. 301. It is the purpose of this Act, among other things, to maintain the control of the United States over all the channels of interstate and foreign radio transmission; and to provide for the use of such channels, but not the ownership thereof, by persons for limited periods of time, under licenses granted by Federal authority, and no such license shall be construed to create any right, beyond the terms, conditions, and periods of the license. No person shall use or operate any apparatus for the transmission of energy or communications or signals by radio (a) from one place in any Territory or possession of the United States or in the District of Columbia to another place in the same Territory, possession, or district; or (b) from any State, Territory, or possession of the United States, or from the District of Columbia to any other State, Territory, or possession of the United States; or (c) from any place in any State, Territory, or possession of the United States, or in the District of Columbia, to any place in any foreign country or to any vessel; or (d) within any State when the effects of such use extend beyond the borders of said State, or when interference is caused by such use or operation with the transmission of such energy, communications, or signals from within said State to any place beyond its borders, or from any

AMATEUR REGULATIONS

The regulations governing amateur radio in the United States are contained in a booklet "Federal Communications Commission Rules and Regulations, Part 12, Rules governing Amateur Radio Stations and Operators" obtainable for 5c (stamps not accepted) from the Government Printing Office, Washington, D. C. The current edition of this booklet contains only those rules intended to be permanent; for additional emergency and (probably) temporary rules in effect as we go to press see page 540; it is probable that copies of any later additions or amendments will be available in mimeographed form from the F.C.C.

place beyond its borders to any place within said State, or with the transmission or reception of such energy, communications, or signals from and/or to places beyond the borders of said State; or (e) upon any vessel or aircraft of the United States; or (f) upon any other mobile stations within the jurisdiction of the United States, except under and in accordance with this Act and with a license in that behalf granted under the provisions of this Act.

Sec. 303. Except as otherwise provided in this Act, the Commission from time to time, as public convenience, interest, or necessity requires, shall—

(1) Have authority to prescribe the qualifications of station operators, to classify them according to the duties to be performed, to fix the forms of such licenses, and to issue them to such citizens of the United States as the Commission finds qualified;

(m) (1) Have authority to suspend the license of any operator upon proof sufficient to satisfy the Commission that the licensee—

(A) Has violated any provision of any Act, treaty, or convention binding on the United States which the Commission is authorized to administer, or any regulation made by the Commission under any such Act, treaty, or convention; or

(B) Has failed to carry out a lawful order of the master or person lawfully in charge of the ship or aircraft on which he is employed; or

(C) Has willfully damaged or permitted radio apparatus or installations to be damaged; or

(D) Has transmitted superfluous radio communications or signals or communications containing profane or obscene words, language, or meaning, or has knowingly transmitted—

(1) False or deceptive signals or communications, or

(2) A call signal or letter which has not been assigned by proper authority to the station he is operating; or

(E) Has willfully or maliciously interfered with any other radio communications or signals; or

(F) Has obtained or attempted to obtain, or has assisted another to obtain or attempt to obtain, an operator's license by fraudulent means.

(2) No order of suspension of any operator's license shall take effect until fifteen days' notice in writing thereof, stating the cause for the proposed suspension, has been given to the operator licensee who may make

written application to the Commission at any time within said fifteen days for a hearing upon such order. The notice to the operator licensee shall not be effective until actually received by him, and from that time he shall have fifteen days in which to mail the said application. In the event that physical conditions prevent mailing of the application at the expiration of the fifteen-day period, the application shall then be mailed as soon as possible thereafter, accompanied by a satisfactory explanation of the delay. Upon receipt by the Commission of such application for hearing, said order of suspension shall be held in abeyance until the conclusion of the hearing which shall be conducted under such rules as the Commission may prescribe. Upon the conclusion of said hearing the Commission may affirm, modify, or revoke said order of suspension.

(n) Have authority to inspect all radio installations associated with stations required to be licensed by any Act or which are subject to the provisions of any Act, treaty, or convention binding on the United States, to ascertain whether in construction, installation, and operation they conform to the requirements of the rules and regulations of the Commission, the provisions of any Act, the terms of any treaty or convention binding on the United States, and the conditions of the license or other instrument of authorization under which they are constructed, installed, or operated.

(r) Make such rules and regulations and prescribe such restrictions and conditions, not inconsistent with law, as may be necessary to carry out the provisions of this Act, or any international radio or wire communications treaty or convention, or regulations annexed thereto, including any treaty or convention insofar as it relates to the use of radio, to which the United States is or may hereafter become a party.

Sec. 318. The actual operation of all transmitting apparatus in any radio station for which a station license is required by this Act shall be carried on only by a person holding an operator's license issued hereunder, and no person shall operate any such apparatus in such station except under and in accordance with an operator's license issued to him by the Commission: *Provided, however,* That the Commission if it shall find that the public interest, convenience, or necessity will be served thereby may waive or modify the foregoing provisions of this section for the operation of any station except (1) stations for which licensed operators are required by international agreement, (2) stations for which licensed operators are required for safety pur-

poses, (3) stations engaged in broadcasting and (4) stations operated as common carriers on frequencies below thirty thousand kilocycles: *Provided further*, That the Commission shall have power to make special regulations governing the granting of licenses for the use of automatic radio devices and for the operation of such devices.

Sec. 321. (a) The transmitting set in a radio station on shipboard may be adjusted in such a manner as to produce a maximum of radiation, irrespective of the amount of interference which may thus be caused, when such station is sending radio communications or signals of distress and radio communication relating thereto.

(b) All radio stations, including Government stations and stations on board foreign vessels when within the territorial waters of the United States, shall give absolute priority to radio communications or signals relating to ships in distress; shall cease all sending on frequencies which will interfere with hearing a radio communication or signal of distress, and, except when engaged in answering or aiding the ship in distress, shall refrain from sending any radio communications or signals until there is assurance that no interference will be caused with the radio communications or signals relating thereto, and shall assist the vessel in distress, so far as possible, by complying with its instructions.

Sec. 322. Every land station open to general public service between the coast and vessels or aircraft at sea shall, within the scope of its normal operations, be bound to exchange radio communications or signals with any ship or aircraft station at sea; and each station on shipboard or aircraft at sea shall, within the scope of its normal operations, be bound to exchange radio communications or signals with any other station on shipboard or aircraft at sea or with any land station open to general public service between the coast and vessels or aircraft at sea: *Provided*, That such exchange of radio communication shall be without distinction as to radio systems or instruments adopted by each station.

Sec. 325. (a) No person within the jurisdiction of the United States shall knowingly utter or transmit, or cause to be uttered or transmitted, any false or fraudulent signal of distress, or communication relating thereto, nor shall any broadcasting station rebroadcast the program or any part thereof of another broadcasting station without the express authority of the originating station.

Sec. 326. Nothing in this Act shall be understood or construed to give the Commission the power of censorship over the radio

communications or signals transmitted by any radio station, and no regulation or condition shall be promulgated or fixed by the Commission which shall interfere with the right of free speech by means of radio communication. No person within the jurisdiction of the United States shall utter any obscene, indecent, or profane language by means of radio communication.

Sec. 358. The radio installation, the operators, the regulation of their watches, the transmission and receipt of messages, and the radio service of the ship except as they may be regulated by law or international agreement, or by rules and regulations made in pursuance thereof, shall in the case of a ship of the United States be under the supreme control of the master.

Sec. 501. Any person who willfully and knowingly does or causes or suffers to be done any act, matter, or thing, in this Act prohibited or declared to be unlawful, or who willfully and knowingly omits or fails to do any act, matter, or thing in this Act required to be done, or willfully and knowingly causes or suffers such omission or failure, shall, upon conviction thereof, be punished for such offense, for which no penalty (other than a forfeiture) is provided herein, by a fine of not more than \$10,000 or by imprisonment for a term of not more than two years, or both.

Sec. 502. Any person who willfully and knowingly violates any rule, regulation, restriction, or condition made or imposed by the Commission under authority of this Act, or any rule, regulation, restriction, or condition made or imposed by any international radio or wire communications treaty or convention, or regulations annexed thereto, to which the United States is or may hereafter become a party, shall, in addition to any other penalties provided by law, be punished, upon conviction thereof, by a fine of not more than \$500 for each and every day during which such offense occurs.

Sec. 605. No person receiving or assisting in receiving, or transmitting, or assisting in transmitting, any interstate or foreign communication by wire or radio shall divulge or publish the existence, contents, substance, purport, effect, or meaning thereof, except through authorized channels of transmission or reception, to any person other than the addressee, his agent, or attorney, or to a person employed or authorized to forward such communication to its destination, or to proper accounting or distributing officers of the various communicating centers over which the communication may be passed, or to the master of a ship under whom he is serving,

ance!

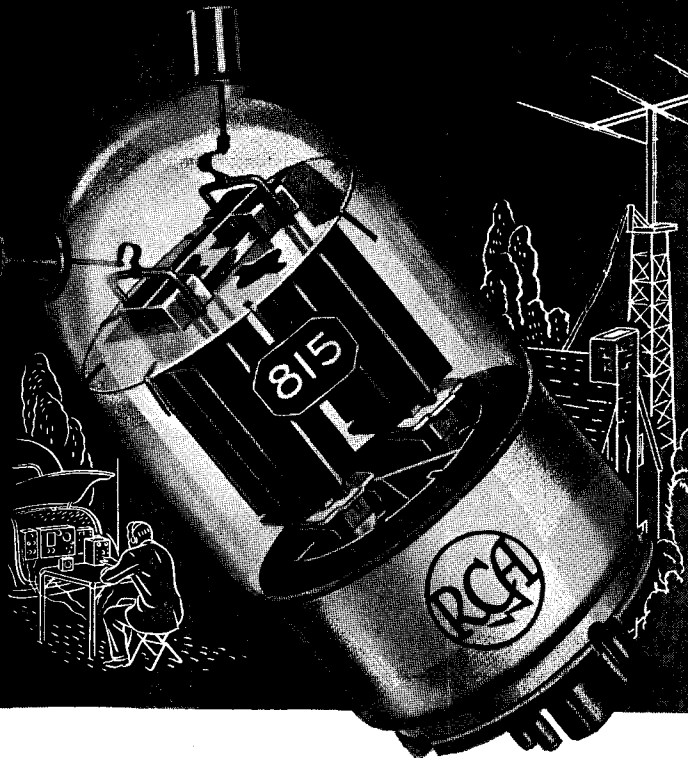

TRANSMITTING TUBES

Type	Max. Input	Amateur Net Price
Triode	42 Watts	\$ 1.45
Pentode	33 Watts	1.50
Pentode	350 Watts	28.50
Pentode	150 Watts	15.00
Triode	314 Watts	28.50
Triode	1000 Watts	28.50
Triode	75 Watts	1.50
Triode	200 Watts	1.50
Triode	100 Watts	1.50
Triode	480 Watts	9.00
Triode	225 Watts	1.50
Triode	225 Watts	1.50
Triode	260 Watts	1.50
Triode Beam	75 Watts	1.50
Triode Curv. Amp.	100 Watts	14.50
Triode	270 Watts	17.50
UHF Triode	125 Watts	18.50
Triode	75 Watts	1.50
Triode	24 Watts	1.50

In CCS, tube is operated at continuous duty.

MERCURY-VAPOR TUBES

Type	Max. Input	Amateur Net Price
866-A	10,000 Volts, 0.25 a.	1.50
872	7,500 Volts, 1.25 a.	9.00
872-A	10,000 Volts, 1.25 a.	11.00

TELEVISION TUBES

No.	Description	Amateur Net Price
3AP4/906P4	3" Kinescope	\$13.75
5AP4/1805P4	5" Kinescope (Short Bulb)	22.00
5BP4/1802P4	5" Kinescope	22.00
1847	Amateur Iconoscope	24.50

CATHODE-RAY TUBES

No.	Screen	Amateur Net Price
3AP1/906P1	3" Green Phosphor	\$13.50
902	2" Green Phosphor	7.50
913	1" Green Phosphor	4.00

UHF ACORN TUBES

No.	Description	Amateur Net Price
954	Pentode Amplifier, Detector	\$5.00
955	Triode Detector, Oscillator	3.00
956	Pentode, Super-Control Amp.	5.00
957	Triode, 1.25-v., 0.05-a. filament	3.00
958	Triode, 1.25-v., 0.1-a. filament	3.00
959	Pentode, 1.25-v., 0.05-a. filament	5.00

RCA Tubes have always been noted for their big, extra measure of dependability. For years, however, amateurs have told us that RCA Ratings based on the most exacting commercial use were too conservative for intermittent amateur use. So now, two sets of ratings are given for popular amateur tube types—the old CCS (Continuous Commercial Service) and the new ICAS (Intermittent Commercial and Amateur Service) Ratings. You take your choice, based on your own individual requirements. You eliminate guesswork, and, as an amateur, you get higher power output at lower cost plus long tube life, plus the utmost in economy of weight and space.

PRACTICAL HELP . . . FREE!



Do you get your free copy of *RCA Ham Tips*, the helpful little publication for amateurs, by amateurs? If not, see your RCA Transmitting Tube Distributor.



NEW

for

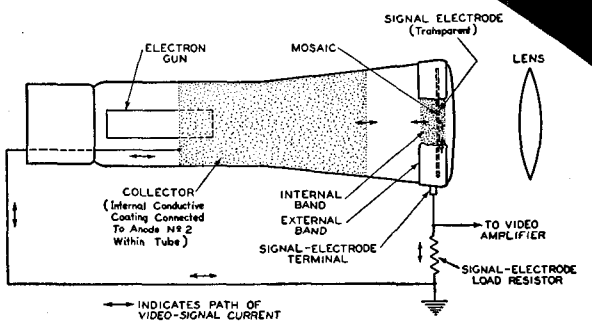
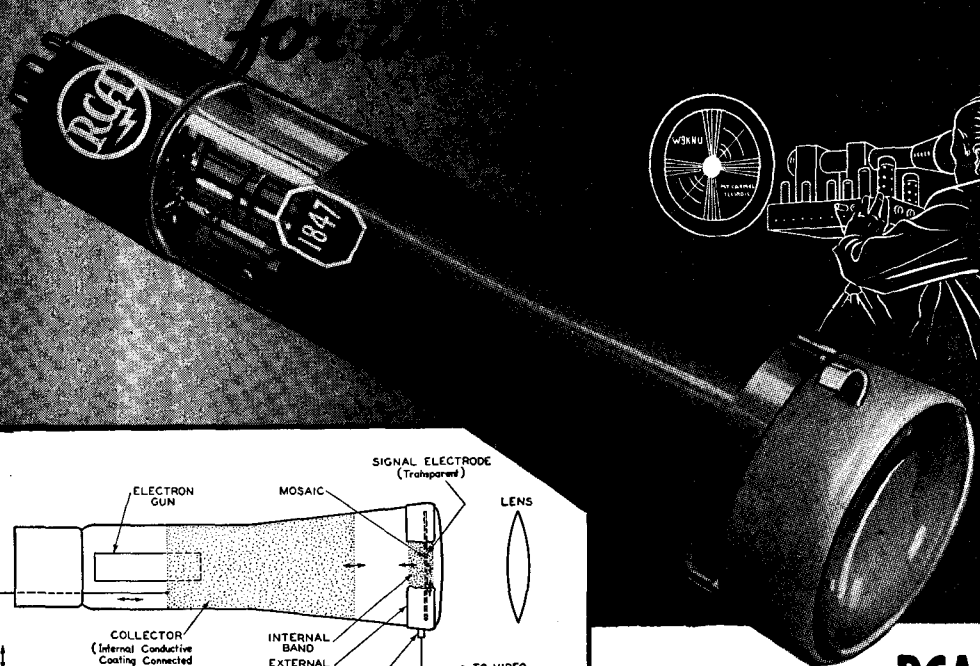

RCA-1847

AMATEUR ICONOSCOPE

"Mini-Ike" is the little brother of the big studio-type Iconoscopes. It is capable of producing clear pictures suitable for transmission in the 2½- or 1¼-meter bands, operates at relatively low voltage, employs inexpensive deflection circuits, and can utilize low-cost, short-focal-length lenses. *Amateur net \$24.50*

New fields to conquer—interesting new experiments to be tried—new thrills of achievement! That is the story of Amateur Television, the most fascinating development in amateur radio today!

An experimental amateur outfit produced under supervision of the same RCA engineers who have led the way in Television proves the practicability of good quality Amateur Television communication with simplified, economical apparatus that many a ham can build for himself. Even skeptics are frankly amazed at the faithful reproduction and stability of the pictures and with the simplicity of the complete equipment.

Based on a series of articles published in QST, this equipment utilizing the RCA 1847 "Mini-Ike" Iconoscope is described in detail in a booklet—free on request—or which may be obtained from your RCA Amateur Equipment Distributor. It tells you what to build and how to build it. And you'll be surprised to learn how much of your present equipment can be used—how little there is to buy.

RCA Ham Guide

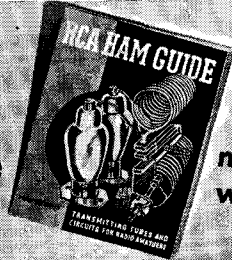

The Booklet no Amateur will want to miss

Just the booklet you've been waiting for! New circuits, new outfits, new diagrams for beginners as well as advanced amateurs. PLUS easy-to-use information on the complete line-up of RCA Transmitting Tubes for amateur needs. 48 pages. *Amateur net 15¢*

or in response to a subpoena issued by a court of competent jurisdiction, or on demand of other lawful authority; and no person not being authorized by the sender shall intercept any communication and divulge or publish the existence, contents, substance, purport, effect, or meaning of such intercepted communication to any person; and no person not being entitled thereto shall receive or assist in receiving any interstate or foreign communication by wire or radio and use the same or any information therein contained for his own benefit or for the benefit of another not entitled thereto; and no person having received such intercepted communication or having become acquainted with the contents, substance, purport, effect, or meaning of the same or any part thereof, knowing that such information was so obtained, shall divulge or publish the existence, contents, substance, purport, effect, or meaning of the same or any part thereof, or use the same or any information therein contained for his own benefit or for the benefit of another not entitled thereto: *Provided*, That this section shall not apply to the receiving, divulging, publishing, or utilizing the contents of any radio communication broadcast, or transmitted by amateurs or others for the use of the general public, or relating to ships in distress.

INTERNATIONAL TELECOMMUNICATION CONVENTION, MADRID, 1932

Article 24

§ 1. The contracting governments agree to take all the measures possible, compatible with the system of telecommunication used, with a view to insuring the secrecy of international correspondence.

* * * *

Article 34

§ 1. Stations carrying on radio communications in the mobile service shall be bound, within the scope of their normal operation, to exchange radio communications with one another irrespective of the radio system they have adopted.

Article 35

§ 1. All stations, regardless of their purpose, must, so far as possible, be established and operated in such a manner as not to interfere with the radio services or communications of either the other contracting governments,

or the private operating agencies recognized by these contracting governments and of other duly authorized operating agencies which carry on radio-communication service.

Article 36

Stations participating in the mobile service shall be obliged to accept, with absolute priority, distress calls and messages regardless of their origin, to reply in the same manner to such messages, and immediately to take such action in regard thereto as they may require.

Article 37

The contracting governments agree to take the steps required to prevent the transmission or the putting into circulation of false or deceptive distress signals or distress calls, and the use, by a station, of call signals which have not been regularly assigned to it.

GENERAL RADIO REGULATIONS (CAIRO REVISION, 1938)

ANNEXED TO THE INTERNATIONAL TELECOMMUNICATIONS CONVENTION (MADRID 1932)

Article 2

44 The administrations agree to take the necessary measures to prohibit and prevent:

45 (a) the unauthorized interception of radio communications not intended for the general use of the public;

46 (b) the divulging of the contents or of the mere existence, the publication or any use whatever, without authorization, of the radio communication mentioned in No. 45.

Article 3

47 § 1. (1) No transmitting station may be established or operated by any person or by any enterprise whatever without a special license issued by the government of the country to which the station in question is subject.

* * * *

Article 6

69 § 1. The waves emitted by a station must be kept on the authorized frequency as exactly as the state of the art permits, and their radiation must be as free as practically

possible from all emissions not essential to the type of communication carried on.

71 § 2. (1) The state of the art in the various cases of operation is defined in appendixes 1, 2, and 3, concerning the exactitude of the frequency, the level of harmonics, and the width of the frequency band occupied.

* * * *

76 § 3. (1) The administrations shall frequently check the waves emitted by the stations under their jurisdiction to determine whether or not they comply with the provisions of the present Regulations.

* * * *

Article 9

203 § 2. The frequency of emission of mobile stations shall be verified as often as possible by the inspection service to which they are subject.

* * * *

Article 11

276 § 1. The radio service of a mobile station shall be placed under the supreme authority of the master or the person responsible for the ship, aircraft, or any other vehicle carrying the mobile station.

* * * *

278 § 3. The master or responsible person as well as any persons who may have knowledge of the text or simply the existence of radiotelegrams, or of any information acquired by means of the radio service, shall be bound by the obligation to observe and insure the secrecy of the correspondence.

Article 12

279 § 1. (1) The competent governments or administrations of countries where a mobile station calls, may demand the production of the license. The operator of the mobile station or the person responsible for the station must submit to this verification. The license must be kept in such a way that it may be furnished without delay. However, the production of the license may be replaced by a permanent posting in the station, of a copy of the license certified by the authority which has granted it.

* * * *

Article 17

374 § 2. (1) Before transmitting, any station must keep watch over a sufficient interval to assure itself that it will cause no harmful

interference with the transmissions being made within its range; if such interference is likely, the station shall await the first stop in the transmission which it may disturb.

* * * *

Article 22

525 § 1. (1) The transmission of unnecessary or unidentified signals or correspondence shall be forbidden to all stations.

527 (2) Tests and experiments shall be permitted in mobile stations if they do not interfere with the service of other stations. As for stations other than mobile stations, each administration shall judge, before authorizing them, whether or not the proposed tests or experiments are likely to interfere with the service of other stations.

* * * *

Article 24

542 1. No provision of these Regulations shall prevent a mobile station in distress from using any means available to it for drawing attention, signalling its position, and obtaining help.

* * * *

548 3. (2) Aircraft. Any aircraft in distress must transmit the distress call on the watching-wave of the land or mobile stations capable of helping it; when the call is addressed to stations of the maritime service, the waves to be used are the distress-wave or watching-wave of these stations.

549 § 4. (1) In radiotelegraphy, the distress signal shall consist of the group . . . — — — . . . transmitted as one signal, in which the dashes must be emphasized so as to be distinguished clearly from the dots.

550 In radiotelephony, the distress signal shall consist of the spoken expression Mayday (corresponding to the French pronunciation of the expression "m'aider").

551 (2) These distress signals shall announce that the ship, aircraft, or any other vehicle which sends the distress signal is threatened by serious and imminent danger and requests immediate assistance.

* * * *

555 § 5. (4) This call shall have absolute priority over other transmissions. All stations hearing it must immediately cease all transmission capable of interfering with the distress traffic and must listen on the wave used for the distress call. This call must not be sent to any particular station and shall not require an acknowledgment of receipt.



PYRANOL CAPACITORS

Cost Less because They Last Longer

PYRANOL is a non-inflammable, non-explosive dielectric developed and patented by General Electric. Its extraordinary insulating and dielectric properties make possible the unusual compactness of G-E capacitors. Thousands of them are in service all over the world. Quality-controlled materials, carefully supervised manufacture, and years of tested application experience all combine to give hams an unexcelled product.

Hermetical sealing assures permanence of the characteristics of Pyranol capacitors; contamination from air and moisture is impossible. G-E Pyranol capacitors are noted for their long life. Write for bulletin GEA-2021B.

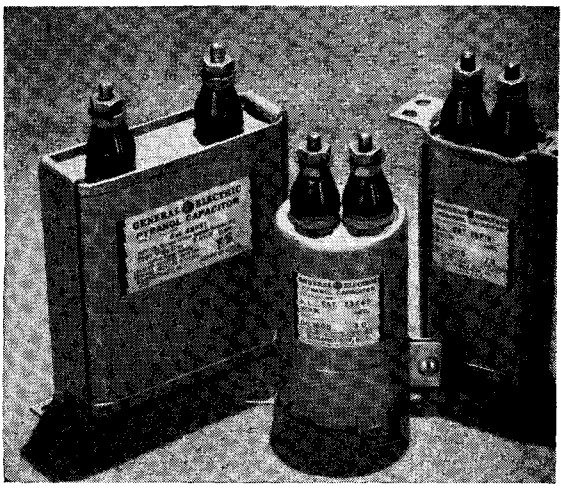

RATINGS AND PRICES

Cylindrical Cases

Volts D.C	Mfd	Catalog No.	Net Price*
600	2	23F60	\$1.95
	3	23F61	2.25
	4	23F62	2.70
1000	1	23F63	1.65
	2	23F64	2.25
	3	23F65	2.55
	4	23F66	2.85
1500	0.5	23F67	1.80
	1.0	23F68	2.10
	2.0	23F69	2.85
2000	1.0	23F70	2.70
	2.0	23F71	3.00

RATINGS AND PRICES

Rectangular Cases

Volts D.C	Mfd	Base Mounting		Inverted Mounting	
		Cat. No.	Net Price*	Cat. No.	Net Price*
600	1	23F1	\$2.10	26F172	\$2.10
	2	23F2	2.55	26F167	2.55
	4	23F4	3.30	26F106	3.30
1000	1	23F10	2.25	26F156	2.25
	2	23F11	3.00	26F157	3.00
	4	23F13	3.75	26F93	3.75
	5	23F14	4.50	26F176	4.50
1500	1	23F20	2.70	26F181	2.70
	2	23F21	3.75	26F182	3.75
	4	23F23	5.10	26F184	5.10
	5	23F24	5.40	26F185	5.40
2000	1	23F30	3.30	26F190	3.30
	2	23F31	3.90	26F191	3.90
	4	23F33	5.40	26F193	5.40
	5	23F34	6.00	26F194	6.00
2500	1	23F39	4.80	26F199	4.80
	2	23F40	7.80	26F200	7.80
	4	23F41	10.80	26F201	10.80
3000	1	23F42	7.20	26F202	7.20
	2	23F43	9.00	26F203	9.00
	4	23F44	13.20	26F204	13.20
4000	0.5	23F45	10.80	26F205	10.80
	1	23F46	13.20	26F206	13.20
	2	23F47	16.80	26F207	16.80
5000	0.5	23F48	12.00	26F208	12.00
	1	23F49	15.00	26F209	15.00
	2	23F50	19.20	26F210	19.20

LOW CAPACITY, SMALL SIZE UNITS

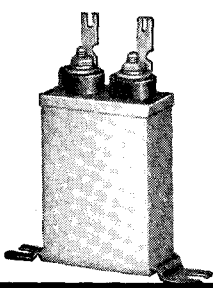

Volts D.C	Mfd	Catalog No.	Net Price*
500	1.0	23F54	\$1.80
1000	0.01	23F55	1.20
1000	0.05	23F56	1.35
1000	0.1	23F57	1.50
1000	0.25	23F58	1.65
1000	0.5	23F59	1.80

* Represents 40% off list price.

GE TRANSMITTING TUBES

Priced Low . . . Unsurpassed in Value

GENERAL ELECTRIC has designed and built tubes to meet the most exacting requirements on land and sea and in the air for more than 27 years. G.E. on a transmitting tube assures you of long, dependable service

at low cost. Bulletin GEA-3315 lists the complete G-E transmitting-tube line, together with technical data and prices. Ask your dealer for a copy or write to General Electric, Schenectady, N. Y.

G-E BEAM POWER TUBES

for More Power with Less Equipment
Low Driving Power
Quick Band Change

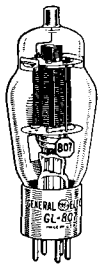

GL-807 NET \$3.50

The G-E beam tube for your low-power requirements. Oscillator, amplifier, frequency multiplier or modulator—you can't buy a more versatile performer for \$3.50! Less than half a watt drives two 807's; ICAS cw output: 100 watts!

GL-814 NET \$17.50

The G-E beam power tube for any medium-power r-f application up to 30 mc. 160 watt cw, 130 watts plate-modulated phone (ICAS) with 1.5 or 3.2 watts driving power respectively. A fb frequency multiplier, too. \$17.50 puts one in your rig.



GL-813 NET \$22.00

The G-E beam tube for high power. It will produce 150 watts cw as a crystal oscillator, 260 watts cw with only 0.5 watt driving power. An excellent frequency multiplier. Makes quick band change at high power easy.

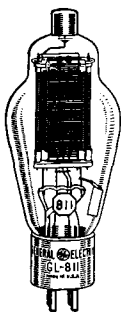

FOR ECONOMICAL MEDIUM POWER

GL-811 . . . High Mu Triode
ICAS* Class B Modulator Rating (2 tubes)
Max. Plate Volts 1500
Max. Plate Current 200 mls
Driving Power 10.5 watts
Output Power 225 watts

NET \$3.50

GL-812 Low Mu Triode
ICAS* Class C Telegraph Rating
Max. Plate Volts 1500
Max. Plate Current 150 mls
Driving Power 6.5 watts
Power Output 170 watts
Max. Frequency 100 mc.

NET \$3.50

*Intermittent Commercial and Amateur Service

G-E MERCURY-VAPOR RECTIFIERS

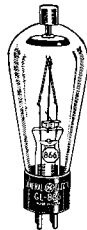

GL-866 NET \$1.50

Max. Peak Inverse Volts 7500
Peak Plate Current 1 amp
Average Plate Current 0.25 amp

GL-866A NET \$2.50

Max. Peak Inverse Volts 10,000
Peak Plate Current 1 amp
Average Plate Current 0.25 amp

FOR HEAVY DUTY

GL-872 NET \$9.00

Max. Peak Inverse Volts 7500
Peak Plate Current 5 amp
Average Plate Current 1.25 amp

GL-872A NET \$11.00

Max. Peak Inverse Volts . . . 10,000
Peak Plate Current 5 amp
Average Plate Current . . . 1.25 amp



TOPS IN "50-WATTERS"

GL-838

Class B Audio 260 watts output (2 tubes)
Class C Telephony 100 watts output
Class C Telegraph 130 watts output
Max. Frequency 30 mc at full input, 120 mc at reduced ratings

NET \$11.00

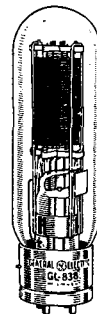

NET PRICES	
GL-203A	\$10.00
GL-211	10.00
GL-800	10.00
GL-801	3.45
GL-802	3.50
GL-803	3.50
GL-805	28.50
GL-806	13.50
GL-807	22.00
GL-809	3.50
GL-809	2.50
GL-810	2.50
GL-811	13.50
GL-812	3.50
GL-813	3.50
GL-813	22.00
GL-814	17.50
GL-833	85.00
GL-837	7.50
GL-838	11.00
GL-845	10.00
GL-860	32.50
GL-866	1.50
GL-866A	2.50
GL-872	9.00
GL-872A	11.00
GL-1623	2.50

556 § 6. (1) The distress call must be followed as soon as possible by the distress message. This message shall include the distress call followed by the name of the ship, aircraft, or the vehicle in distress, information regarding the position of the latter, the nature of the distress and the nature of the help requested, and any other further information which might facilitate this assistance.

557 (2) When, in its distress message, an aircraft is unable to signal its position, it shall endeavor after the transmission of the incomplete message to send its call signal long enough so that the radio direction-finding stations may determine its position.

558 § 7. (1) As a general rule, a ship or aircraft at sea shall signal its position in latitude and longitude (Greenwich) using figures, for the degrees and minutes, accompanied by one of the words North or South and one of the words East or West. A period shall separate the degrees from the minutes. In some cases, the true bearings and the distance in nautical miles from some known geographical point may be given.

* * * *

560 (3) As a general rule, an aircraft flying over land shall signal its position by the name of the nearest locality, its approximate distance from this point, accompanied, according to the case, by one of the words North, South, East, or West, or, in some cases, words indicating intermediate directions.

561 § 8. The distress call and message shall be sent only by order of the master or person responsible for the ship, aircraft, or other vehicle carrying the mobile station.

* * * *

569 § 11. (1) Stations of the mobile service which receive a distress message from a mobile station which is unquestionably in their vicinity, must acknowledge receipt thereof at once (see Nos. 587, 588, and 589). If the distress call has not been preceded by an auto-alarm signal, these stations may transmit this auto-alarm signal with the authorization of the authority responsible for the station (for mobile stations, see No. 276), taking care not to interfere with the transmission of the acknowledgment of the receipt of said message by other stations.

570 (2) Stations of the mobile service which receive a distress message from a mobile station which unquestionably is not in their vicinity, must wait a short period of time before acknowledging receipt thereof, in order to make it possible for stations nearer to the

mobile station in distress to answer and acknowledge receipt without interference.

* * * *

573 § 14. The control of distress traffic shall devolve upon the mobile station in distress or upon the mobile station which, by application of the provisions of No. 567, has sent the distress call. These stations may delegate the control of the distress traffic to another station.

* * * *

604 § 22. (2) In radiotelephony the urgent signal shall consist of three transmissions of the expression PAN (corresponding to the French pronunciation of the word "panne"); it shall be transmitted before the call.

605 (3) The urgent signal shall indicate that the calling station has a very urgent message to transmit concerning the safety of a ship, an aircraft, or another vehicle, or concerning the safety of some person on board or sighted from on board.

606 (4) In the aeronautical service, the urgent signal PAN shall be used in radiotelegraphy and in radiotelephony to indicate that the aircraft transmitting it is in trouble and is forced to land, but that it is not in need of immediate help. This signal should, so far as possible, be followed by a message giving additional information.

607 (5) The urgent signal shall have priority over all other communications, except distress communications, and all mobile or land stations hearing it must take care not to interfere with the transmission of the message which follows the urgent signal.

608 (6) In case the urgent signal is used by a mobile station, this signal must, as a general rule, subject to the provisions of No. 606, be addressed to a definite station.

* * * *

612 § 25. (1) The urgent signal may be transmitted only with the authorization of the master or of the person responsible for the ship, aircraft, or any other vehicle carrying the mobile station.

613 (2) In the case of a land station, the urgent signal may be transmitted only with the approval of the responsible authority.

* * * *

615 § 26. (1) In radiotelegraphy, the safety signal shall consist of the group TTT, transmitted three times, with the letters of each group, as well as the consecutive groups, well separated. This signal shall be followed by the word DE and three transmissions of the

call signal of the station sending it. It announces that this station is about to transmit a message concerning the safety of navigation or giving important meteorological warnings.

616 (2) In radiotelephony, the word Security (corresponding to the French pronunciation of the word "sécurité") repeated three times, shall be used as the safety signal.

* * * *

619 § 28. (2) All stations hearing the safety signal must continue listening on the wave on which the safety signal has been sent until the message so announced has been completed; they must moreover keep silence on all waves likely to interfere with the message.

Rules Governing Amateur Radio: Stations and Operators

DEFINITIONS

12.1. **Amateur service.**—The term "amateur service" means a radio service carried on by amateur stations.

12.2. **Amateur station.**—The term "amateur station" means a station used by an "amateur," that is, a duly authorized person interested in radio technique solely with a personal aim and without pecuniary interest. It embraces all radio transmitting apparatus at a particular location used for amateur service and operated under a single instrument of authorization.

12.3. **Amateur portable station.**—The term "amateur portable station" means an amateur station that is portable in fact, that is so constructed that it may conveniently be moved about from place to place for communication, and that is in fact so moved from time to time, but which is not operated while in motion.

12.4. **Amateur portable-mobile station.**—The term "amateur portable-mobile station" means an amateur station that is portable in fact, that is so constructed that it may conveniently be transferred to or from a mobile unit or from one such unit to another, and that is in fact so transferred from time to time and is ordinarily used while such mobile unit is in motion.

12.5. **Amateur radio communication.**—The term "amateur radio communication" means radio communication between amateur stations solely with a personal aim and without pecuniary interest.

12.6. **Amateur operator.**—The term "am-

Article 26

Order of Priority of Communications in the Mobile Service

653 The order of priority of radio communications in the mobile service shall be as follows:

1. Distress calls, distress messages, and distress traffic;
2. Communications preceded by an urgent signal;
3. Communications preceded by a safety signal;
4. Communications relative to radio direction-finding bearings;
5. Government radiotelegrams for which priority right has not been waived;
6. All other communications.

ateur operator" means a person holding a valid license issued by the Federal Communications Commission authorizing him to operate licensed amateur stations.

AMATEUR OPERATORS

Licenses—Privileges

12.21. **Eligibility for license.**—The following are eligible to apply for amateur operator license and privileges:

Class A—A United States citizen who has within 5 years of receipt of application held license as an amateur operator for a year or who in lieu thereof qualified under section 12.46.

Class B—Any United States citizen.

Class C—A United States citizen whose actual residence, address, and station are more than 125 miles airline from the nearest point where examination is given at least quarterly for class B; or is shown by physician's certificate to be unable to appear for examination due to protracted disability; or is shown by certificate of the commanding officer to be in a camp of the Civilian Conservation Corps or in the regular military or naval service of the United States at a military post or naval station and unable to appear for class B examination.

Be Right with OHMITE

DUMMY ANTENNA RESISTOR To Check R.F. Power and Tune Up

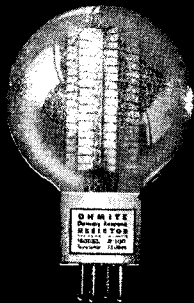

Check your R.F. Power and tune up to peak efficiency — determine transmission line losses—check line to antenna impedance match — all through the use of this new Ohmite Dummy Antenna. Non-inductive, non-capacitive, constant in resistance. Mounts in standard tube socket.

Model D-100, 100 watts, in popular 73 ohm and 600 ohm resistance values. Also in 13, 18, 34, 64, 100, 146, 219, 300, 400, 500 ohm values.

List Price \$5.50

Model D-250, 250 watts, in 73 ohm and 600 ohm values. **List Price** \$11

Send for Free Dummy Antenna Bulletin 111A

Patents Pending

PARASITIC SUPPRESSOR

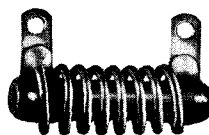

Ohmite P-300 Parasitic Suppressor—convenient, compact, efficient . . . designed to prevent ultra-high-frequency parasitic oscillations which occur in the plate and grid leads of push-pull and parallel tube circuits. Non-inductive, vitreous-enamelled resistor combined with a choke into one small integral unit. Only 1 1/4" long overall and 5/8" diameter.

List Price \$1.50

CENTER-TAPPED RESISTORS

Especially designed for use across tube filaments to provide an electrical center for the grid and plate returns. Center tap accurate to plus or minus 1%. Available in Wirewatt (1 watt) and Brown Devil (10 watt) units, in resistances from 10 to 200 ohms.

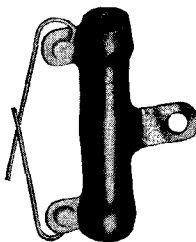

POPULAR BROWN DEVILS

There's good reason for the world-wide popularity of Ohmite "Brown Devil" Resistors. They're tough, extra-sturdy units — built right, sealed tight and permanently protected by Ohmite Vitreous Enamel. 10 and 20 watt sizes, in resistances from 1 to 100,000 ohms.

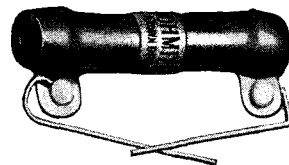

R. F. PLATE CHOKES

High frequency solenoid chokes designed to avoid either fundamental or harmonic resonance in the amateur bands. Single-layer wound on low power factor steatite cores with non-magnetic mounting brackets. Moisture-proof. Built to carry A THOUSAND MA. 4 stock sizes for 5 to 160 meter bands.

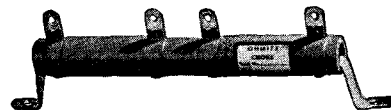

R. F. POWER LINE CHOKES

Just the thing to keep R. F. currents from going out over the power line, lessen interference with BCL receivers. Also to prevent high frequency and R. F. interference from coming in to the receiver. 3 stock sizes, rated at 5, 10, and 20 amperes. Consists of two chokes wound on a single core. Details in Bulletin 105.

SEND FOR YOUR FREE COPY OF NEW CATALOG 18

RHEOSTATS * RESISTORS * SWITCHES * CHOKES

** Ohmite Vitreous Enamel is well-known as a protective and bonding covering for power rheostats and resistors.*

Vitreous-Enameled RHEOSTATS

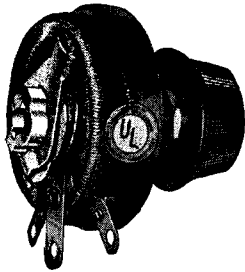

These are the rheostats used by amateurs and broadcast stations alike to keep power tube filaments at rated value all the time—**increase tube life—get peak efficiency.** Time-proved Ohmite all-porcelain vitreous-enamelled construction and metal-graphite contact assure permanent smooth, safe, exact control. Available in 25, 50, 75, 100, 150, 225, 300, 500, and 1,000 watt sizes, for all tubes and transmitters. (Underwriters' Laboratories Listed).

Available in 25, 50, 75, 100, 150, 225, 300, 500, and 1,000 watt sizes, for all tubes and transmitters. (Underwriters' Laboratories Listed).

OHMITE BAND-SWITCH

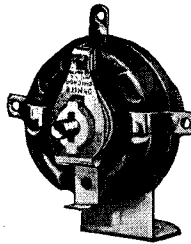

A flick-of-the-wrist on the knob of this popular Ohmite Band-Change-Switch gives you instant, easy change from one frequency to another, with really low-loss efficiency. Band changing may be provided in all stages of the transmitter, and "ganged" for complete front-of-panel control. Can be used in rigs up to 1 K.W. rating.



FIXED RESISTORS

These are the same dependable Ohmite vitreous-enamelled resistors that are almost universally used by eminent designers and manufacturers of amateur and commercial transmitters and receivers. Available in 25, 50, 100, 160, and 200 watt stock sizes, in resistances from 5 to 250,000 ohms.

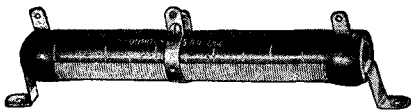

ADJUSTABLE DIVIDOHMS

Mighty handy resistors to have around when you need a change of resistor value or a replacement in a hurry. You can quickly adjust the Dividohms to the exact resistance you want and put on one or more taps wherever needed. Patented percentage of resistance scale. 7 ratings from 10 to 200 watts. Resistances up to 100,000 ohms.

Ask Your Jobber for the Ohmite parts you need, or Write today for Catalog 18.

All-Enclosed High-Current OHMITE TAP SWITCHES

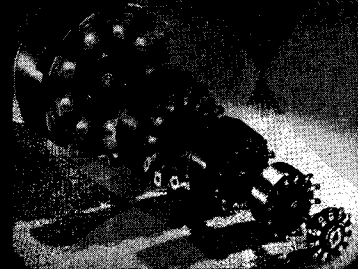

Multi-point, load-break, non-shorting, single-pole, rotary selector switches particularly designed for alternating current use. Ideal for high current circuit switching in transmitter power supply and many heavy duty industrial applications. All-enclosed, ceramic construction. Extremely compact yet perfectly insulated. Self-cleaning, silver-silver contacts. "Slow-break," quick-make action. Shafts electrically "dead"—insulated with steatite. Available in single or tandem units; in 10, 15, 25, 50 and 100 ampere models, 1 3/4" diam. to 6" diam.

Send for Tap Switch Bulletin

Patents Pending

OHMITE

OHMITE MANUFACTURING CO.
4857 FLOURNOY STREET
CHICAGO, U.S.A. • *Cable "Ohmiteco"*

12.22. Classification of operating privileges.

—Amateur operating privileges are as follows:

Class A—All amateur privileges.

Class B—Same as class A except specially limited as in section 12.116.

Class C—Same as class B.

12.23. Scope of operator authority.—Amateur operators' licenses are valid only for the operation of licensed amateur stations; *Provided, however,* Any person holding a valid radio operator's license of any class may operate stations in the experimental service licensed for, and operating on, frequencies above 300000 kilocycles.

12.24. Posting of license.—The original operator's license shall be posted in a conspicuous place in the room occupied by such operator while on duty or kept in his personal possession and available for inspection at all times while the operator is on duty, except when such license has been filed with application for modification or renewal, or has been mutilated, lost, or destroyed, and application has been made for a duplicate.

12.25. Duplicate license.—Any licensee applying for a duplicate license to replace an original which has been lost, mutilated, or destroyed, shall submit to the Commission such mutilated license or affidavit attesting to the facts regarding the manner in which the original was lost or destroyed. If the original is later found, it or the duplicate shall be returned to the Commission.

12.26. Renewal of amateur operator license.—An amateur operator license may be renewed upon proper application and a showing that within 3 months of receipt of the application by the Commission the licensee has lawfully operated an amateur station licensed by the Commission, and that he has communicated by radio with at least three other such amateur stations. Failure to meet the requirements of this section will make it necessary for the applicant to again qualify by examination.

12.27. Who may operate an amateur station.—An amateur station may be operated only by a person holding a valid amateur operator's license, and then only to the extent provided for by the class of privileges for which the operator's license is endorsed. When an amateur station uses radiotelephony (type A-3 emission) the licensee may permit any person to transmit by voice, provided a duly licensed amateur operator maintains control over the emissions by turning the carrier on and off when required and signs the station off after the transmission has been completed.

Examinations

12.41. When required.—Examination is required for a new license as an amateur operator or for change of class of privileges.

12.42. Elements of examination.—The examination for amateur operator privileges will

comprise the following elements:

1. Code test—ability to send and receive, in plain language, messages in the International Morse Code at a speed of not less than 13 words per minute, counting 5 characters to the word, each numeral or punctuation mark counting as 2 characters.
2. Amateur radio operation and apparatus, both telephone and telegraph.
3. Provisions of treaty, statute, and regulations affecting amateurs.
4. Advanced amateur radiotelephony.

12.43. Elements required for various privileges.—Examinations for class A privileges will include all four examination elements as specified in section 12.42.

Examinations for classes B and C privileges will include elements 1, 2, and 3 as set forth in section 12.42.

12.44. Manner of conducting examination.—Examinations for class A and class B privileges will be conducted by an authorized Commission employee or representative at points specified by the Commission.

Examinations for class C privileges will be given by volunteer examiner(s), whom the Commission may designate or permit the applicant to select; in the latter event the examiner giving the code test shall be a holder of an amateur license with class A or B privileges, or have held within 5 years a license as a professional radiotelegraph operator or have within that time been employed as a radiotelegraph operator in the service of the United States; and the examiner for the written test, if not the same individual, shall be a person of legal age.

12.45. Additional examination for holders of class C privileges.—The Commission may require a licensee holding class C privileges to appear at an examining point for a class B examination. If such licensee fails to appear for examination when directed to do so, or fails to pass the supervisory examination, the license held will be canceled and the holder thereof will not be issued another license for the class C privileges.

Whenever the holder of class C amateur operator privileges changes his actual residence or station location to a point where he would not be eligible to apply for class C privileges in the first instance, or whenever a new examining point is established in a region from which applicants were previously eligible for class C privileges, such holders of class C privileges shall within 4 months thereafter appear at an examining point and be examined for class B privileges. The license will be canceled if such licensee fails to appear, or fails to pass the examination.

12.46. Examination abridgment.—An applicant for class A privileges, who holds a license with class B privileges, will be required to pass only the added examination element No. 4. (See Sec. 12.42.)

A holder of class C privileges will not be accorded an abridged examination for either class B or class A privileges.

An applicant who has held a license for the class of privileges specified below, within 5 years prior to receipt of application, will be credited with examination elements as follows:

Class of license or privileges: <i>Credits</i>	
Commercial extra	
first	Elements 1, 2, and 4.
Radiotelegraph	
first, second, or	
third	Elements 1 and 2.
Radiotelephone	
first or second...	Elements 2 and 4.
Class A	Elements 2 and 4.

No examination credit is given on account of license of radiotelephone third class, nor for other class of license or privileges not above listed.

12.47. Examination procedure.—Applicants shall write examinations in longhand—code tests and diagrams in ink or pencil, written tests in ink—except that applicants unable to do so because of physical disability may typewrite or dictate their examinations and, if unable to draw required diagrams, may make instead a detailed description essentially equivalent. The examiner shall certify the nature of the applicant's disability and, if the examination is dictated, the name and address of the person(s) taking and transcribing the applicant's dictation.

12.48. Grading.—Code tests are graded as passed or failed, separately for sending and receiving tests. A code test is failed unless free of omission or other error for a continuous period of at least 1 minute at required speed. Failure to pass the required code test will terminate the examination. (See section 12.49.)

A passing grade of 75 percent is required separately for class B and class A written examinations.

12.49. Eligibility for reexamination.—An applicant who fails examination for amateur privileges may not take another examination for such privileges within 2 months, except that this rule shall not apply to an examination for class B following one for class C.

AMATEUR RADIO STATIONS

Licenses

12.61. Eligibility for amateur station license.—License for an amateur station will be issued only to a licensed amateur operator who has made a satisfactory showing of control of proper transmitting apparatus and control of the premises upon which such apparatus is to be located: *Provided, however,* that in the case of an amateur station of the military or Naval Reserve of the United States located in approved public quarters and

established for training purposes, but not operated by the United States Government, a station license may be issued to a person in charge of such a station although not a licensed amateur operator.

12.62. Eligibility of corporations or organizations to hold license.—An amateur station license will not be issued to a school, company, corporation, association, or other organization; nor for their use: *Provided, however,* That in the case of a bona-fide amateur radio society a station license may be issued in accordance with section 12.61 to a licensed amateur operator as trustee for such society.

12.63. Location of station.—An amateur radio station, and the control point thereof when remote control is authorized, shall not be located on premises controlled by an alien.

12.64. License period.—License for an amateur station will normally be for a period of 3 years from the date of issuance of a new, renewed, or modified license.

12.65. Authorized operation.—An amateur station license authorizes the operation of all transmitting apparatus used by the licensee at the location specified in the station license and in addition the operation of portable and portable-mobile stations at other locations under the same instrument of authorization.

12.66. Renewal of amateur station license.—An amateur station license may be renewed upon proper application and a showing that, within 3 months of receipt of the application by the Commission, the licensee thereof has lawfully operated such station in communication by radio with at least three other amateur stations licensed by the Commission, except that in the case of an application for renewal of station license issued for an amateur society or reserve group, the required operation may be by any licensed amateur operator. Upon failure to comply with the above requirements, a successor license will not be granted until 2 months after expiration of the old license.

12.67. Posting of station license.—The original of each station license or a facsimile thereof shall be posted by the licensee in a conspicuous place in the room in which the transmitter is located or kept in the personal possession of the operator on duty, except when such license has been filed with application for modification or renewal, or has been mutilated, lost, or destroyed, and application has been made for a duplicate.

Call Signals

12.81. Assignment of call letters.—Amateur station calls will be assigned in regular order and special requests will not be considered except that a call may be reassigned to the latest holder, or if not under license during the past 5 years to any previous holder, or to an amateur organization in memoriam to a deceased member and former holder, and particular calls may be temporarily assigned

They may

Type BR — "Blue Beavers"

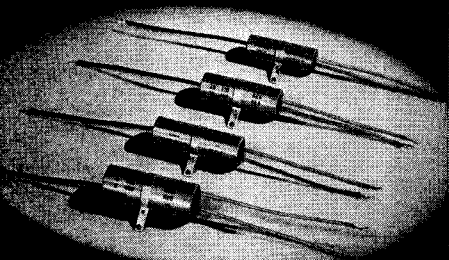

Type BRL — dual "Beavers"

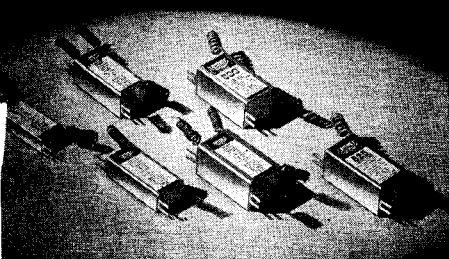

Type JR, JRC and JRX

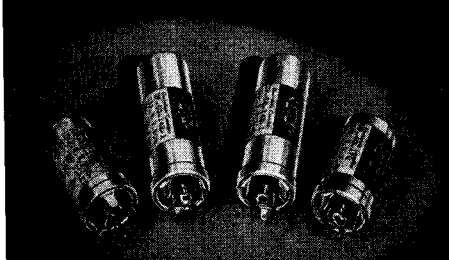

Type UP — Electrolytics



Type EX and EY

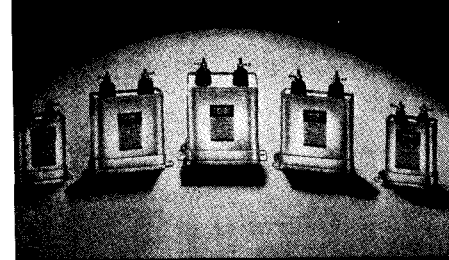

Type TJU Dykanol Capacitors

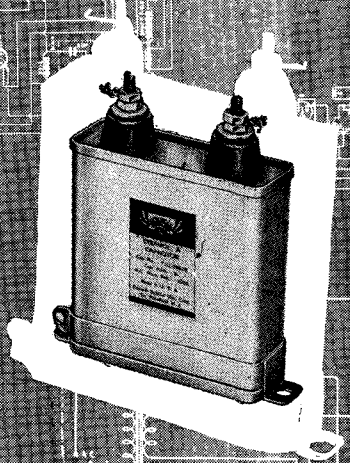

but

... put to the test, all capacitors are not alike. They differ in life span, in number of advanced features, in dependability. Unfortunately the eye cannot see these important differences. There is a way however that you can be sure you're getting

demand **CORNELL - DUBILIER**

MICA CAPACITORS

Widely imitated, copied but never duplicated, patented C-D micas are serving in thousands of homes the world over.

DYKANOL TRANSMITTING CAPACITORS

Carefully designed, compact, light-weight, safety-rated, furnished with universal mounting clamps, well insulated terminals. Fire-proof, these units are without a doubt the most dependable capacitors offered the radio amateur.

PAPER CAPACITORS

C-D Tubular and Bypass Paper Capacitors have established an international reputation for outstanding dependability and economy. Available in all capacities of 400, 500 and 1000 V.D.C.

WET DRY ELECTROLYTIC CAPACITORS

Outstanding in the complete C-D line of electrolytics is the type BR "Blue Beaver"—world's smallest 500 V. electrolytic. Use "Blue Beavers"—save space, save time—get better all round performance.

look alike

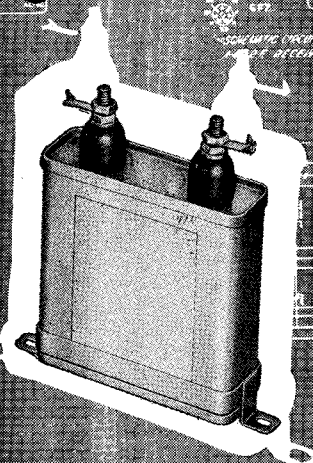

the all-around tops in capacitor value. Look for the name **CORNELL-DUBILIER** on the label. Only capacitors bearing this name are backed by laboratory life tests for performance, and the specialized experience of 30 manufacturing years—your guarantee of outstanding performance on the job.

CORNELL-DUBILIER

*the top name
in capacitors*

For the complete listing of all C-D Capacitors, Condensers for Test Instruments and Oscillators Interference Filters, ask your local C-D distributor for Cat. 135A. Or write to Cornell-Dubilier Electric Corp., So. Plainfield, N.J.

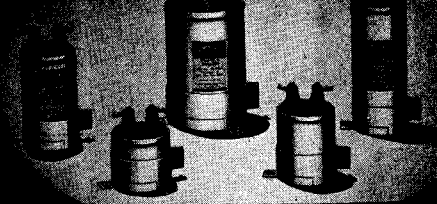

Type TQ Dykanol Capacitors

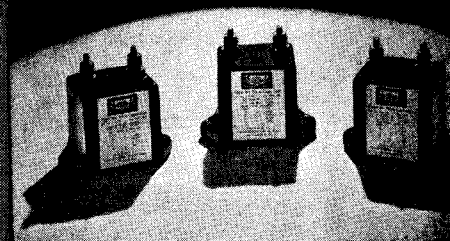

Type 86 Mica Capacitors



Types 4 and 9 Mica Capacitors

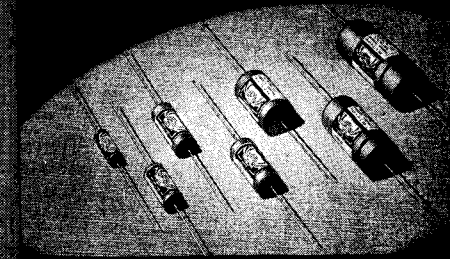

Type DT—"Dwarf Tigers"

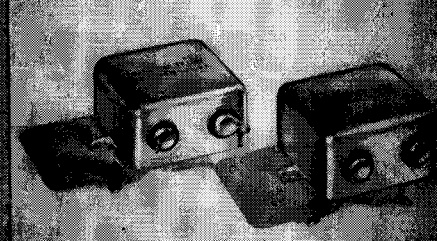

Type DYR Dykanol Bypass



BF-50 Capacitor Analyzer

to stations connected with events of general public interest.

12.82. Call signals for member of U. S. N. R.—In the case of an amateur licensee whose station is licensed to a regularly commissioned or enlisted member of the United States Naval Reserve, the Commandant of the naval district in which such station is located may authorize, in his discretion, the use of the call-letter prefix N in lieu of the prefix W or K, assigned in the license issued by the Commission, provided that such N prefix shall be used only when operating in the frequency bands 1750–2050 kilocycles, 3500–4000 kilocycles, 56000–60000 kilocycles, and 400000–401000 kilocycles in accordance with instructions to be issued by the Navy Department.

12.83. Transmission of call signals.—An operator of an amateur station shall transmit its assigned call at the end of each transmission and at least once every 10 minutes during transmission of more than 10 minutes' duration; *Provided, however,* That transmission of less than 1 minute duration from stations employing break-in operation need be identified only once every 10 minutes of operation and at the termination of the correspondence. In addition, an operator of an amateur portable or portable-mobile radiotelegraph station shall transmit immediately after the call of the station the fraction-bar character (\overline{DN}) followed by the number of the amateur call area in which the portable or portable-mobile amateur station is then operating, as for example:

Example 1.—Portable or portable-mobile amateur station operating in the third amateur call area calls a fixed amateur station: W1ABC W1ABC W1ABC DE W2DEF \overline{DN} 3 W2DEF \overline{DN} 3 W2DEF \overline{DN} 3 AR.

Example 2.—Fixed amateur station answers the portable or portable-mobile amateur station: W2DEF W2DEF W2DEF DE W1ABC W1ABC W1ABC \overline{K} .

Example 3.—Portable or portable-mobile amateur station calls a portable or portable-mobile amateur station: W3GHI W3GHI W3GHI DE W4JKL \overline{DN} 4 W4JKL \overline{DN} 4 W4JKL \overline{DN} 4 AR.

If telephony is used, the called sign of the station shall be followed by an announcement of the amateur call area in which the portable or portable-mobile station is operating.

Portable and Portable-Mobile Stations

(For emergency regulations temporarily prohibiting most portable and portable-mobile communication, see F.C.C. orders after Regulation 2.53.)

12.91. Requirements for portable and portable-mobile operation.—A licensee of an

amateur station may operate portable amateur stations (section 12.3) in accordance with the provisions of sections 12.82, 12.83 12.92, and 12.136. Such licensee may operate portable and portable-mobile amateur stations without regard to section 12.92, but in compliance with sections 12.82, 12.83, and 12.136, when such operation takes place on authorized amateur frequencies above 28000 kilocycles.

12.92. Special provisions for portable stations.—Advance notice in writing shall be given by the licensee to the inspector in charge of the district in which such portable station is to be operated. Such notices shall be given prior to any operation contemplated, and shall state the station call, name of licensee, the date of proposed operation, and the locations as specifically as possible. An amateur station operating under this section shall not be operated during any period exceeding 1 month without giving further notice to the inspector in charge of the radio-inspection district in which the station will be operated, nor more than four consecutive periods of 1 month at the same location. This section does not apply to the operation of portable or portable-mobile amateur stations on frequencies above 28000 kilocycles. (See section 12.91.)

12.93. Special provisions for nonportable stations.—The provisions for portable stations shall not be applied to any nonportable station except that—

(a) An amateur station that has been moved from one permanent location to another permanent location may be operated at the latter location in accordance with the provisions governing portable stations for a period not exceeding 60 days, but in no event beyond the expiration date of the license, provided an application for modification of license to change the permanent location has been made to the Commission.

(b) The licensee of an amateur station who is temporarily residing at a location other than the licensed location for a period not exceeding 4 months may for such period operate his amateur station at his temporary address in accordance with the provision governing portable stations.

Use of Amateur Stations

12.101. Points of communication.—An amateur station shall communicate only with other amateur stations, except that in emergencies or for testing purposes it may be used also for communication with commercial or Government radio stations. In addition, amateur stations may communicate with any mobile radio station which is licensed by the Commission to communicate with amateur stations, and with stations of expeditions which may also be authorized to communicate with amateur stations. They may also make transmissions to points equipped only with receiving apparatus for the measurement of emissions, observation of transmission phenomena,

radio control of remote objects, and similar purely experimental purposes.

(For emergency regulations temporarily prohibiting communication with foreign countries, see F.C.C. orders after Regulation 2.53.)

12.102. No remuneration for use of station.

—An amateur station shall not be used to transmit or receive messages for hire, nor for communication for material compensation, direct or indirect, paid or promised.

12.103. Broadcasting prohibited.—An amateur station shall not be used for broadcasting any form of entertainment, nor for the simultaneous retransmission by automatic means of programs or signals emanating from any class of station other than amateur.

12.104. Radiotelephone tests.—The transmission of music by an amateur station is forbidden. However, single audio-frequency tones may be transmitted by radiotelephony for test purposes of short duration in connection with the development of experimental radiotelephone equipment.

Allocation of Frequencies

12.111. Frequencies for exclusive use of amateur stations.—The following bands of frequencies are allocated exclusively for use by amateur stations:

1750 to 2050 kilocycles.
 3500 to 4000 kilocycles.
 7000 to 7300 kilocycles.
 14000 to 14400 kilocycles.
 28000 to 30000 kilocycles.
 56000 to 60000 kilocycles.
 112000 to 116000 kilocycles.
 224000 to 230000 kilocycles.
 400000 to 401000 kilocycles.

12.112. Use of frequencies above 300000 kilocycles.—The licensee of an amateur station may, subject to change upon further order, operate amateur stations, with any type of emission authorized for amateur stations, on any frequency above 300000 kilocycles without separate licenses therefor.

12.113. Individual frequency not specified.—Transmissions by an amateur station may be on any frequency within the bands assigned. Sideband frequencies resulting from keying or modulating a transmitter shall be confined within the frequency band used.

12.114. Types of emission.—All bands of frequencies allocated to the amateur service may be used without modulation (type A-1 emission).

12.115. Additional bands for types of emission using amplitude modulation.—The following bands of frequencies are allocated for use by amateur stations using additional types of emission as shown:

1750 to	2050 kilocycles	—	—	A-4	—
1800 to	2000 kilocycles	—	A-3	—	—
28500 to	30000 kilocycles	—	A-3	—	—
56000 to	60000 kilocycles	A-2	A-3	A-4	—
112000 to	116000 kilocycles	A-2	A-3	A-4	A-5

224000 to 230000 kilocycles A-2 A-3 A-4 A-5
 400000 to 401000 kilocycles A-2 A-3 A-4 A-5

12.116. Additional bands for radiotelephony.

—Amateur stations may use radiotelephony with amplitude modulation (type A-3 emission) in the frequency bands 3900 to 4000 kilocycles and 14150 to 14250 kilocycles, provided the station is licensed to a person who holds an amateur operator license endorsed with class A privileges, and actually is operated by an amateur operator holding class A privileges.

12.117. Frequency modulation.—The following bands of frequencies are allocated for use by amateur stations for radiotelephone frequency modulation transmissions:¹

58500 to 60000 kilocycles
 112000 to 116000 kilocycles
 224000 to 230000 kilocycles
 400000 to 401000 kilocycles

Equipment and Operation

12.131. Maximum power input.—The licensee of an amateur station is authorized to use a maximum power input of 1 kilowatt to the plate circuit of the final amplifier stage of an oscillator-amplifier transmitter or to the plate circuit of an oscillator transmitter. An amateur transmitter operating with a power input exceeding 900 watts to the plate circuit shall provide means for accurately measuring the plate power input to the vacuum tube, or tubes, supplying power to the antenna.

12.132. Power supply to transmitter.—The licensee of an amateur station using frequencies below 60000 kilocycles shall use adequately filtered direct-current plate power supply for the transmitting equipment to minimize frequency modulation and to prevent the emission of broad signals.

12.133. Requirements for prevention of interference.—Spurious radiations from an amateur transmitter operating on a frequency below 60000 kilocycles shall be reduced or eliminated in accordance with good engineering practice and shall not be of sufficient intensity to cause interference on receiving sets of modern design which are tuned outside the frequency band of emission normally required for the type of emission employed. In the case of A-3 emission, the transmitter shall not be modulated in excess of its modulation capability to the extent that interfering spurious radiations occur, and in no case shall the emitted carrier be amplitude-modulated in excess of 100 percent. Means shall be employed to insure that the transmitter is not modulated in excess of its modulation capability. A spurious radiation is any radiation from a transmitter which is outside the frequency band of emission normal for the type of transmission employed, including any com-

¹ When using frequency modulation no simultaneous amplitude modulation is permitted.

U. S. GOVERNMENT
AIRLINES
MANUFACTURERS
BROADCASTERS

rely on **JOHNSON**

- Antennas
- Insulators
- Condensers
- Inductors
- Tube Sockets
- Plugs & Jacks

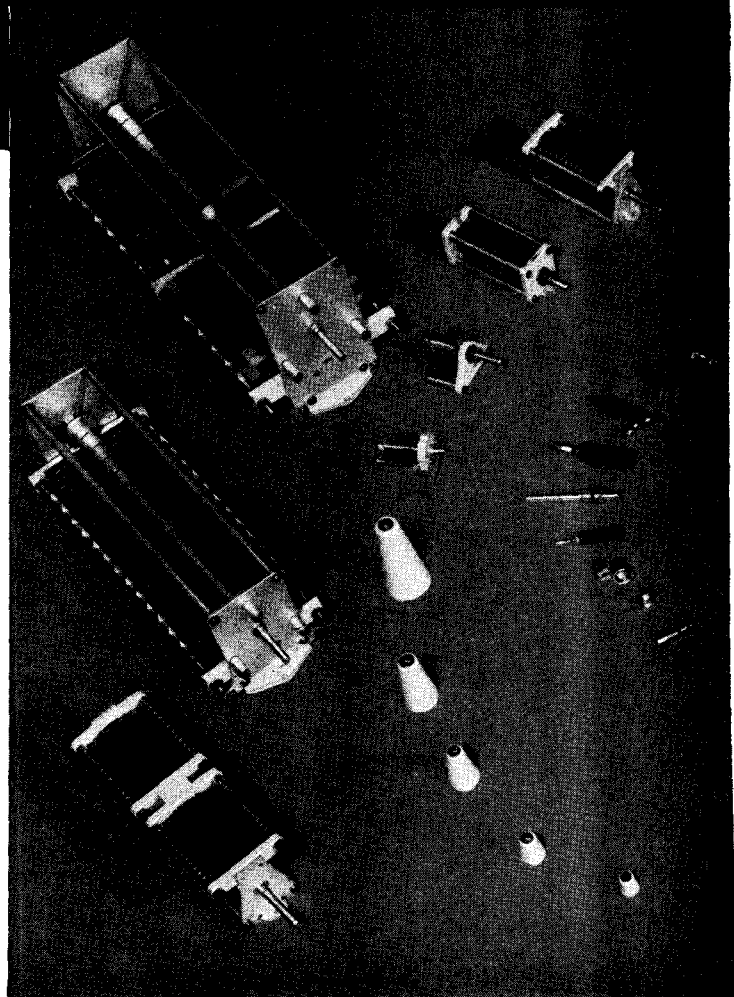

Famous Johnson products are being used by every big name manufacturer of diathermy and radio transmitting equipment. These same identical parts are available to you from your jobber. We could not crowd even a representative showing of the line into the above photograph but your jobber has a catalog for you including the Johnson-Bassett antenna and concentric feeder line. Don't use cheap inferior products when the best cost no more. Compare Johnson prices and you will be agreeably surprised. The answer? — quantity production.

it's also YOUR guarantee of dependability

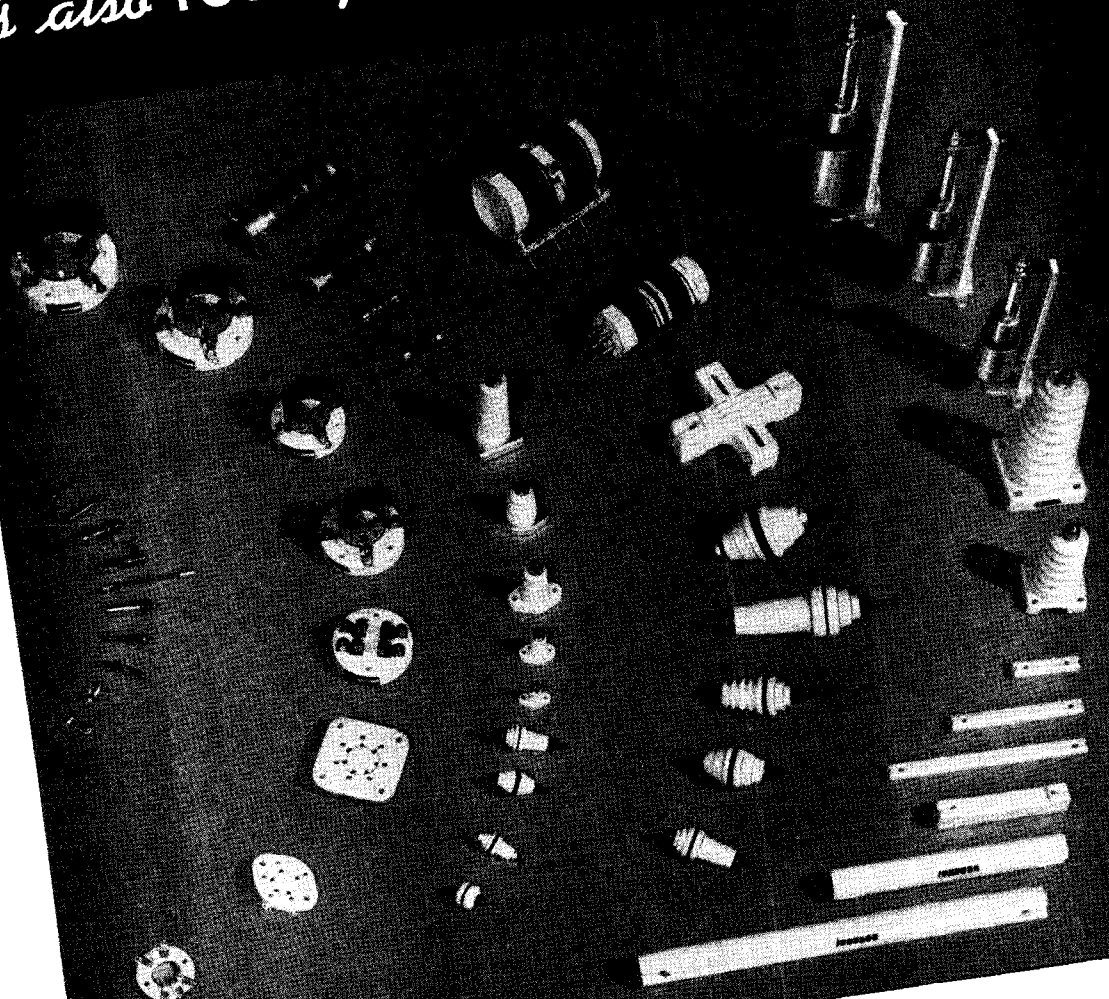

Ask for
CATALOG 966P

Consult your **PARTS JOBBER**

He values your business and will advise you on your problems. He employs amateurs to serve you—make use of their experience. And remember — all better Jobbers can supply Johnson and Johnson-Bassett products.



E. F. JOHNSON CO
WASECA, MINNESOTA

EXPORT: 25 WARREN ST., NEW YORK, N. Y.

MANUFACTURERS OF RADIO TRANSMITTING EQUIPMENT

ponent whose frequency is an integral multiple or submultiple of the carrier frequency (harmonics and subharmonics), spurious modulation products, key clicks, and other transient effects, and parasitic oscillations. The frequency of emission shall be as constant as the state of the art permits.

12.134. **Modulation of carrier wave.**—Except for brief tests or adjustments, an amateur radiotelephone station shall not emit a carrier wave on frequencies below 112000 kilocycles unless modulated for the purpose of communication.

12.135. **Frequency measurement and regular check.**—The licensee of an amateur station shall provide for measurement of the transmitter frequency and establish procedure for checking it regularly. The measurement of the transmitter frequency shall be made by means independent of the frequency control of the transmitter and shall be of sufficient accuracy to assure operation within the frequency band used.

12.136. **Logs.**—Each licensee of an amateur station shall keep an accurate log of station operation, including the following data:

(a) The date and time of each transmission. (The date need only be entered once for each day's operation. The expression "time of each transmission" means the time of making a call and need not be repeated during the sequence of communication which immediately follows; however, an entry shall be made in the log when "signing off" so as to show the period during which communication was carried on.)

(b) The signature of the person manipulating the transmitting key of the radiotelegraph transmitter or the signature of the person operating a transmitter of any other type (type A-3 or A-4 emission) with statement as to type of emission, and the signature of any other person who transmits by voice over a radiotelephone transmitter (type A-3 emission). (The signature need only be entered once in the log, provided the log contains a statement to the effect that all transmissions were made by the person named except where otherwise stated. The signature of any other person who operates the station shall be entered in the proper space for his transmissions.)

(c) Call letters of the station called. (This entry need not be repeated for calls made to the same station during any sequence of communication, provided the time of "signing off" is given.)

(d) The input power to the oscillator, or to the final amplifier stage where an oscillator-amplifier transmitter is employed. (This need be entered only once, provided the input power is not changed.)

(e) The frequency band used. (This information need be entered only once in the log for all transmissions until there is a change in frequency to another amateur band.)

(f) The location of a portable or portable-mobile station at the time of each transmission. (This need be entered only once provided the location of the station is not changed. However, suitable entry shall be made in the log upon changing location, showing the type of vehicle or mobile unit in which the station is operated and the approximate geographical location of the station at the time of operation.)

(g) The message traffic handled. (If record communications are handled in regular message form, a copy of each message sent and received shall be entered in the log or retained on file for at least 1 year.)

The log shall be preserved for a period of at least 1 year following the last date of entry. The copies of record communications and station log, as required under this section, shall be available for inspection upon request by an authorized Government representative.

Special Conditions

12.151. **Additional conditions to be observed by licensee.**—An amateur station license is granted subject to the conditions imposed in sections 12.152 to 12.155, inclusive, in addition to any others that may be imposed during the term of the license. Any licensee receiving due notice requiring the station licensee to observe such conditions shall immediately act in conformity therewith.

12.152. **Quiet hours.**—In the event that the operation of an amateur station causes general interference to the reception of broadcast programs with receivers of modern design, such amateur station shall not operate during the hours from 8 o'clock p. m. to 10:30 p. m., local time, and on Sunday for the additional period from 10:30 a. m. until 1 p. m., local time, upon such frequency or frequencies as cause such interference.

12.153. **Second notice of same violation.**—In every case where an amateur station licensee is cited a second time within a year for the same violation under section 12.111, 12.113, 12.116, 12.117, 12.132, or 12.133, the Commission will direct that the station remain silent from 6 p. m. to 10:30 p. m., local time, until written notice has been received authorizing full-time operations. The licensee shall arrange for tests at other hours with at least two amateur stations within 15 days of the date of notice, such tests to be made for the specific purpose of aiding the licensee in determining whether the emissions of his station are in accordance with the Commission's regulations. The licensee shall report under oath to the Commission at the conclusion of the tests as to the observations reported by amateur licensees in relation to the reported violation. Such reports shall include a statement as to the corrective measures taken to insure compliance with the regulations.

12.154. **Third notice of same violation.**—In

every case where an amateur station licensee is cited the third time within a year for the same violation as indicated in section 12.153, the Commission will direct that the station remain silent from 8 a. m. to 12 midnight, local time, except for the purpose of transmitting a prearranged test to be observed by a monitoring station of the Commission to be designated in each particular case. Upon completion of the test the station shall again remain silent during these hours until authorized by the Commission to resume full-time operation. The Commission will consider the results of the tests and the licensee's past record in determining the advisability of suspending the operator license and/or revoking the station license.

12.155. **Operation in emergencies.**—In the event of widespread emergency conditions affecting domestic communication facilities, the Commission may confer with representatives of the amateur service and others and, if deemed advisable, will declare that a state of general communications emergency exists, designating the licensing area or areas concerned (in general not exceeding 1,000 miles from center of the affected area), whereupon it shall be incumbent upon each amateur station in such area or areas to observe the following restrictions for the duration of such emergency:

(a) No transmissions except those relating to relief work or other emergency service such as amateur nets can afford, shall be made within the 1750-2050 kilocycle or 3500-4000 kilocycle amateur bands. Incidental calling, testing, or working, including casual conversation or remarks not pertinent or necessary to constructive handling of the general situation shall be prohibited.

(b) The frequencies 1975-2000, 3500-3525, and 3975-4000 kilocycles shall be reserved for emergency calling channels, for initial calls from isolated stations or first calls concerning very important emergency relief matters or arrangements. All stations having occasion to use such channels shall, as quickly as possible, shift to other frequencies for carrying on their communications.

(c) A 5-minute listening period for the first 5 minutes of each hour shall be observed for initial calls of major importance, both in the designated emergency calling channels and throughout the 1750-2050 and 3500-4000 kilocycle bands. Only stations isolated or engaged in handling official traffic of the highest priority may continue with transmissions in these listening periods, which must be accurately observed. No replies to calls or resumption of routine traffic shall be made in the 5-minute listening period.

(d) The Commission may designate certain amateur stations to assist in promulgation of its emergency announcement, and for policing the 1750-2050 and 3500-4000 kilocycle bands and warning noncomplying stations noted operating therein. The operators of these

observing stations shall report fully the identity of any stations failing, after due notice, to comply with any section of this regulation. Such designated stations will act in an advisory capacity when able to provide information on emergency circuits. Their policing authority is limited to the transmission of information from responsible official sources, and full reports of noncompliance which may serve as a basis for investigation and action under section 502 of the Communications Act. Policing authority extends only to 1750-2050 and 3500-4000 kilocycle bands. Individual policing transmissions shall refer to this section by number, shall specify the date of the Commission's declaration, the area and nature of the emergency, all briefly and concisely. Policing-observer stations shall not enter into discussions beyond essentials with the stations notified, or other stations.

(e) These special conditions imposed under this section will cease to apply only after the Commission shall have declared such emergency to be terminated.

GENERAL RULES APPLICABLE TO AMATEUR SERVICE

1.71. **Applications made on prescribed forms; exceptions.**—Each application * * * shall be made in writing, subscribed and verified as provided in section 1.121, on a form furnished by or in the manner prescribed by the Commission * * *. The required forms may be obtained from the Commission or from any of its field offices.

1.351. **Place of filing; number of copies.**—Each application * * * shall be submitted as follows:

Class of Station *Number of application forms required and method of filing*
 g. Amateur 1 copy to be sent as follows:
 * * * * *

- (a) To proper district office if it requires personal appearance for operator examination under direct supervision from that office.
- (b) Direct to Washington, D. C., in all other cases, including examinations for class C privileges.

1.360. **Renewal of license.**—Unless otherwise directed by the Commission, each application for renewal of license shall be filed at least 60 days prior to the expiration date of the license sought to be renewed. * * *

Answers to Notices of Violation

1.391. **Under title III of the act.**—Any licensee receiving official notice of a violation

BLILEY

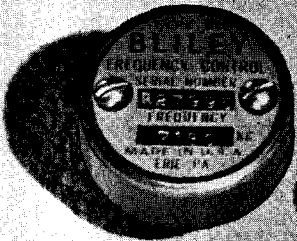

40 METERS
TYPE B5

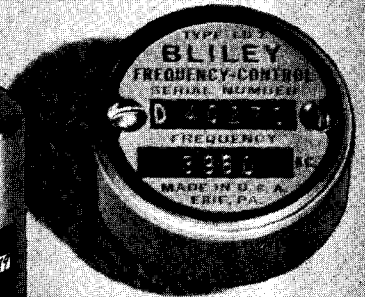

80-160 METERS
TYPE LD2



STANDARD FREQUENCY
108KC. CRYSTAL UNIT
TYPE SOC100

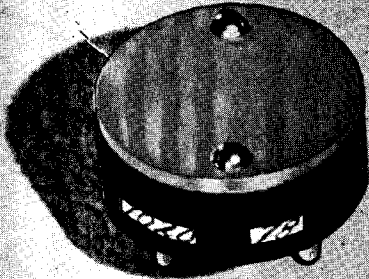

40-80-160 METERS
TYPE BC3

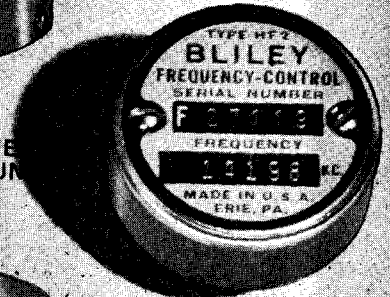

10-20 METERS
TYPE HF2

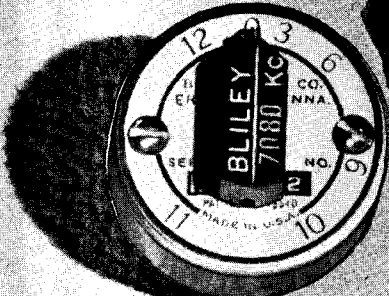

40-80, METERS
VARIABLE FREQUENCY
TYPE VF1



STANDARD FREQUENCY
100KC. CRYSTAL UNIT
TYPE SOC100X

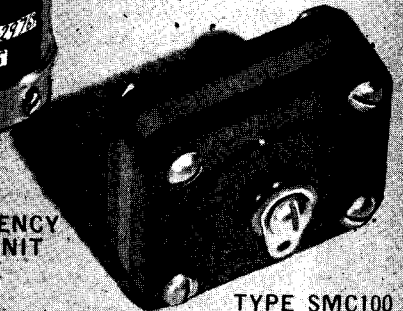

TYPE SMC100
CALIBRATOR CRYSTAL UNIT
100KC.—1000KC.

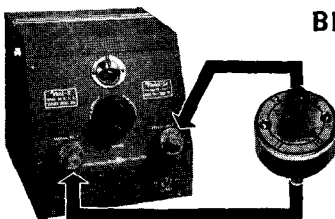

BLILEY VARI-X VARIABLE CRYSTAL OSCILLATOR WITH VF2 CRYSTAL UNIT

Frequency selection is easy with the Vari-X and wide range VF2 Variable Crystal Units. And, you can forget worries about frequency stability (so difficult to obtain with a self-excited oscillator) because the Vari-X is 100% crystal controlled. Circular D2, obtainable from your Bliley Distributor, gives complete information.

CRYSTALS

TYPE B5

Thoroughly engineered in every detail, this compact unit represents the best in a mounted, low-drift, high-frequency quartz crystal. Each crystal is manufactured under rigid standards and has a maximum temperature coefficient of ± 4 cycles/mc./°C.

Price—7.0 to 7.3mc., within
 ± 5 kc. of specified kc.* . \$4.80
 —at specified integral kc. . \$5.90

TYPE BC3

This popular, economically priced crystal unit is fully reliable in every respect. The accurately cut crystal has a high activity with a frequency drift of only 23 cycles/mc./°C. Heat, developed by the crystal, is dissipated by the stainless-steel holder cover-plate thereby reducing actual frequency drift.

Price—40 or 80-meter band,
 within ± 5 kc.* \$3.35
 —at specified integral kc. . \$4.95
 Price—160 meters, within ± 10 kc. \$3.35

TYPE VF1

Avoid QRM by frequency selection. The frequency of the VF1 Variable Frequency Crystal Unit is continuously variable up to 6kc. with the 80-meter unit, or 12kc. with the 40-meter unit. When multiplying, the range is proportionately increased. The specially finished crystal has a drift of less than ± 4 cycles/mc./°C. and an activity only somewhat less than that of high activity fixed-frequency crystals.

Price—40-meter band, minimum
 frequency within ± 15 kc.
 of specified \$6.60
 —within ± 5 kc. \$8.50
 Price—80-meter band, minimum
 frequency within ± 5 kc. . \$6.60
 Price—at specified integral kc. . \$8.50

TYPE LD2

The outstanding crystal unit for the 80 and 160-meter bands. It incorporates a powerful, highly active crystal with a frequency drift of less than ± 4 cycles/mc./°C. Correctly designed and carefully manufactured, this time-proven unit provides accurate, dependable frequency control.

Price—within ± 5 kc. of specified kc.* \$4.80
 Price—at specified integral kc. . \$5.90

TYPE HF2

Crystal control of 2½, 5, 10, and 20-meter transmitters is simplified by the use of the type HF2 High Frequency Crystal Unit. Frequency drift is ± 20 cycles/mc./°C. for the 20-meter unit and ± 43 cycles/mc./°C. for the 10-meter unit.

Price—14.0 to 14.4mc., within
 ± 15 kc. of specified kc.* . \$5.75
 Price—14.4 to 15.0mc., within
 ± 30 kc. of specified kc.* . \$5.75
 Price—28.0 to 30.0mc., ± 50 kc. of
 specified kc. (recommended
 for 2½ and 5 meters only) . \$5.75

TYPE SMC100

Frequency checking, calibrating receivers and signal generators, or performing general frequency measurements is easy with a 100kc. —1000kc. frequency standard. A few stock parts and an SMC100 Dual-Frequency Crystal Unit is all that's needed for construction.

Price \$7.75

TYPE CF1

The Bliley CF1 Crystal Filter Unit, with its high Q and freedom from spurious responses, assures maximum receiver selectivity and minimum signal loss.

Price—456kc., 465kc. or
 500kc. I-F. \$5.50
 Price—1600kc. I-F. \$9.50

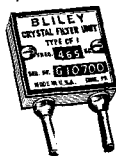

TYPE SOC100

This precision-manufactured, knife-edge mounted, 100kc. bar is designed for use in primary or secondary standards of frequency where high stability and accuracy is essential. The crystal has a maximum temperature coefficient of ± 3 cycles/mc./°C.

Price—calibrated at room temp. . \$15.50
 Price—at specified oven temp. . \$21.00

TYPE SOC100X

A knife-edge mounted 100kc. X-cut bar for applications not requiring the high accuracy and stability of the SOC100 Unit. Temperature coefficient is (—) 10 cycles/mc./°C.

Price—calibrated at room temp. . \$9.50
 Price—at specified oven temp. . \$15.00

Engineering Bulletin E-6, **FREQUENCY CONTROL WITH QUARTZ CRYSTALS**, is a handbook on crystal control. Price, 10¢ (Canada and foreign, 15¢). Descriptive catalogs of Bliley Crystal Units are available at no charge.

Quartz crystals for frequency control and special applications are manufactured for all frequencies from 20kc. to 30mc. Bliley Broadcast Frequency Crystals are approved by the F. C. C. Ask for Catalog G-12.

All prices shown are net in U. S. A.

*Or choice from dealer's stock

of the terms of the Communications Act of 1934, any legislative act, Executive order, treaty to which the United States is a party, or the Rules and Regulations of the Federal Communications Commission, shall, within 3 days from such receipt, send a written answer direct to the Federal Communications Commission at Washington, D. C., and a copy thereof to the office of the Commission originating the official notice when the originating office is other than the office of the Commission in Washington, D. C.: *Provided, however,* That if an answer cannot be sent nor an acknowledgement made within such 3-day period by reason of illness or other unavoidable circumstances, acknowledgment and answer shall be made at the earliest practicable date with a satisfactory explanation of the delay. The answer to each notice shall be complete in itself and shall not be abbreviated by reference to other communications or answers to other notices. If the notice relates to some violation that may be due to the physical or electrical characteristics of transmitting apparatus, the answer shall state fully what steps, if any, are taken to prevent future violations, and if any new apparatus is to be installed, the date such apparatus was ordered, the name of the manufacturer, and promised date of delivery.

* * * * *

If the notice of violation relates to some lack of attention or improper operation of the transmitter, the name * * * of the operator in charge shall be given.

Revocation and Modification of Station Licenses

1.401. **Revocation.**—Whenever the Commission shall institute a revocation proceeding against the holder of any radio station construction permit or license under section 312 (a), it shall initiate said proceeding by serving upon said licensee an order of revocation effective not less than 15 days after written notice thereof is given the licensee. The order of revocation shall contain a statement of the grounds and reasons for such proposed revocation and a notice of the licensee's right to be heard by filing with the Commission a written request for hearing within 15 days after receipt of said order. Upon the filing of such written request for hearing by said licensee the order of revocation shall stand suspended and the Commission will set a time and place for hearing and shall give the licensee and other interested parties notice thereof. If no request for hearing on any order of revocation is made by the licensee against whom such an order is directed within the time hereinabove set forth, the order of revocation shall become final and effective, without further action of the Commission.

* * * * *

Suspension of Operator Licenses

1.411. **Order of suspension.**—No order of suspension of any operator's license shall take effect until 15 days' notice in writing thereof, stating the cause for the proposed suspension, has been given to the operator licensee who may make written application to the Commission at any time within said 15 days for a hearing upon such order. The notice to the operator licensee shall not be effective until actually received by him, and from that time he shall have 15 days in which to mail the said application. In the event that physical conditions prevent mailing of the application at the expiration of the 15-day period, the application shall then be mailed as soon as possible thereafter, accompanied by a satisfactory explanation of the delay. Upon receipt by the Commission of such application for hearing, said order of suspension shall be held in abeyance until the conclusion of the hearing which shall be conducted under such rules as the Commission shall deem appropriate. Upon the conclusion of said hearing the Commission may affirm, modify, or revoke said order of suspension.

1.412. **Proceedings.**—Proceedings for the suspension of an operator's license shall in all cases be initiated by the entry of an order of suspension. Respondent will be given notice thereof together with notice of his right to be heard and to contest the proceeding. The effective date of the suspension will not be specified in the original order but will be fixed by subsequent motion of the Commission in accordance with the conditions specified above. Notice of the effective date of suspension will be given respondent, who shall send his operator license to the office of the Commission in Washington, D. C., on or before the said effective date, or, if the effective date has passed at the time notice is received, the license shall be sent to the Commission forthwith.

2.53. **Operators, place of duty.**—(a) Except as may be provided in the rules governing a particular class of station, one or more licensed operators of the grade specified by these rules and regulations shall be on duty at the place where the transmitting apparatus of each station is located and in actual charge thereof whenever it is being operated; *Provided, however,* That—

(1) Subject to the provisions of paragraph (b) of this section, in the case of a station licensed for service other than broadcast, where remote control is used, the Commission may modify the foregoing requirements upon proper application and showing being made so that such operator or operators may be on duty at the control station in lieu of the place where the transmitting apparatus is located.

(2) In the case of two or more stations, except amateur and broadcast, licensed in the name of the same person to use fre-

VACUUM TANK CONDENSERS



Only 6½ inches long with a diameter of 2¼ inches yet it carries a peak rf voltage rating of 32,000. May be used in a push pull 100% modulated transmitter operating at 4000 volts on the plate . . . higher voltages may be used with single ended transmitters where no modulation is required. Proper combinations of the standard units will produce any desired capacity for optimum circuit efficiencies on any frequency at any voltage. Rf current rating 20 to 50 amperes per unit depending upon frequency.

Capacity	6mmfd	12mmfd	25mmfd	50mmfd
Net price	\$7.50	\$8.50	\$10.50	\$12.50



MERCURY VAPOR RECTIFIERS

	RX21	GRID CONTROL KY21
Filament Voltage	2.5 volts	2.5 volts
Filament Current	10 amperes	10 amperes
Peak Inverse Voltage	11,000 volts	11,000 volts
Peak Plate Current	3 amperes	3 amperes
Average Plate Current	.75 amps.	.75 amps.
NET PRICE	\$7.50	\$10.00

Tube
Result
Released In-

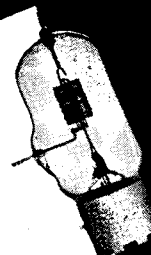

35TG

GIVING TUBES

	35T	35 TG	Twin 30	UH 50	75T	100T	100T	100T	100T	250 TL	250 TH	304 TL	450 T	450 TH	750 TL	1000 UHF T	1500 T	2000 T
Filament Voltage (volts)	5	5 to 5.1	6	7.5	7.5	7.5	7.5	7.5	7.5	5 or 10	5	5	5	7.5	7.5	7.5	7.5	10
Filament Current (amperes)	4	4	4	3.25	3.25	3.25	3.25	3.25	3.25	13 or 6.5	10.5	10.5	10.5	12	21	16	26	26
Amplification Factor	30	30	32	12	12	12	12	12	12	10	10	10	10	10	13.5	30	18.5	18.5
Grid-Plate Capacity (mmfds)	1.9	1.7	1.7	2.3	2.3	2.3	2.3	2.3	2.3	3	3	3	3	4	4.5	4	7	9
Grid-Filament Cap. (mmfds)	4.0	1.5	1.5	2.2	2.2	2.2	2.2	2.2	2.2	5	3.5	10	4	4	6.0	6	10	13
Plate-Filament Cap. (mmfds)	3	3	3	3	3	3	3	3	3	7.5	3	1.5	.6	.6	.8	.6	.9	1
Bulb	S21 Nonex	S21 Nonex	S21 Nonex	S21 Nonex	GT25 Nonex	GT25 Nonex	GT25 Nonex	GT25 Nonex	GT25 Nonex	GT30 Nonex	GT30 Nonex	GT30 Nonex	GT40 Nonex	GT40 Nonex	GT50 Nonex	GT40 Nonex	GT50 Nonex	GT50 Nonex
Base	9-pin	9-pin	9-pin	9-pin	9-pin	9-pin	9-pin	9-pin	9-pin	9-pin	9-pin	9-pin	9-pin	9-pin	9-pin	9-pin	9-pin	9-pin
Overall Height (inches)	5 1/2	5 1/2	4 3/4	7	7 1/2	7 1/2	7 1/2	7 1/2	7 1/2	9 3/4	9 3/4	9 3/4	7 3/4	12 1/2	12 1/2	16 1/2	12 1/2	17 1/2
Maximum Diameter (inches)	1 3/4	1 3/4	2 3/8	2 3/4	3 1/8	3 1/8	3 1/8	3 1/8	3 1/8	3 3/4	3 3/4	3 3/4	5	5	7	5	7	8
Max. Plate Voltage (volts)	2000	2000	2000	1250	3000	3000	3000	3000	3000	3000	3000	3000	6000	6000	6000	6000	6000	6000
Max. Plate Current (amperes)	15	15	85*	125	175	225	225	225	225	500	350	350	1000	500	500	1000	750	1250
Max. Grid Current (milliamperes)	30	30	30*	25	30	35	60	.030	75	50	100	150	75	125	125	125	175	225
Plate Dissipation (watts)	70	70	30*	50	75	100	100	125	150	250	250	300	450	450	750	1000	1500	2000
Power Output (watts)	240	240	175	125	300	400	400	375	600	800	800	1200	1800	1800	3000	3500	5000	7500
Power Output (watts) High Level	50	50	...	100	100	100	350	350	...	500	500	1000	1000	2500	2500
Power Output (watts) Linear Amplifier	25	50	50	125	125	...	125	125	350	350	500	1000
LIST PRICE (NET)	\$6.00	\$6.75	\$13.50	\$12.50	\$9.00	\$13.50	\$13.50	\$28.50	\$20.00	\$24.50	\$24.50	\$65.00	\$75.00	\$75.00	\$175	\$175	\$225	\$300

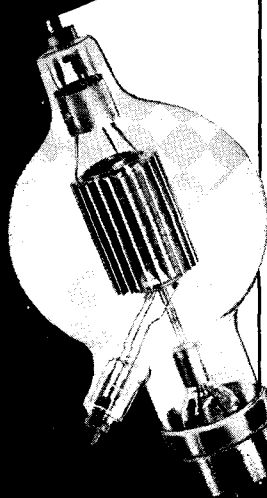

quencies above 30000 kilocycles only, a licensed radio operator of any class except amateur, radiotelephone third class, or holder of restricted operator permit who has the station within his effective control, may be on duty at any point within the communication range of such stations in lieu of the transmitter location or control point during the actual operation of the transmitting apparatus and shall supervise the emissions of all such stations so as to insure the proper operation in accordance with the station license.

(b) Authority to employ an operator at the control point in accordance with paragraph (a) (1) of this section shall be subject to the following conditions:

(1) The transmitter shall be so installed and protected that it is not accessible to other than duly authorized persons.

(2) The emissions of the transmitter shall be continuously monitored at the control point by a licensed operator of the grade specified for the class of station involved.

(3) Provision shall be made so that the transmitter can quickly and without delay be placed in an inoperative condition in the event there is a deviation from the terms of the station license.

(4) The radiation of the transmitter shall be suspended immediately when there is a deviation from the terms of the station license.

Temporary Emergency Orders

It is expected and believed that the following temporary emergency F.C.C. orders (which supersede the regulations in so far as they are in conflict therewith) will be repealed as soon as the international situation is again normal or nearly so.

On June 5, 1940 the F.C.C. issued an order prohibiting communication between amateur radio stations in the U. S. A. (including possessions) and all foreign countries; communication between the continental U. S. A. and U. S. A. possessions is, of course, still permissible, as is communication between the various possessions themselves. (For this purpose the Philippines and Canal Zone have a special status, communication being permissible with those areas only when the station to be contacted is operated by a United States citizen.)

On June 7, and 12, 1940, the F.C.C. issued orders prohibiting portable and portable-mobile operation of amateur radio stations on frequencies below 56 Mc. except (1) when furnishing or attempting to furnish communication service in the public interest in an emergency when normal facilities are inadequate or non-existent and (2) when actually testing self-powered equipment intended for emergency use between sunrise and sunset on Saturdays and Sundays, in which event notice of such intended operation must be given at least 48 hours in advance to the F.C.C. Inspector in charge of the district in which operation is to take place.

R-S-T REPORTING SYSTEM

Readability

1. Unreadable.
2. Barely Readable—Occasional Words Distinguishable.
3. Readable with Considerable Difficulty.
4. Readable with Practically No Difficulty.
5. Perfectly Readable.

Signal Strength

1. Faint—Signals Barely Perceptible.
2. Very Weak Signals.
3. Weak Signals.
4. Fair Signals.
5. Fairly Good Signals.
6. Good Signals.
7. Moderately Strong Signals.
8. Strong Signals.
9. Extremely Strong Signals.

Tone

1. Extremely Rough, Hissing Note.
2. Very Rough A.C. Note—No Trace of Musicality.
3. Rough, Low-Pitched A.C. Note—Slightly Musical.

4. Rather Rough A.C. Note—Moderately Musical.
5. Musically Modulated Note.
6. Modulated Note—Slight Trace of Whistle.
7. Near D.C. Note—Smooth Ripple.
8. Good D.C. Note—Just Trace of Ripple.
9. Purest D.C. Note.

If the Note Appears to Be Crystal Controlled, Simply Add an X after the Appropriate Number.

Fractional-Decimal Equivalentents

A time-saving table is given for fractional-decimal conversion. Many of the commonly used fractions and their decimal equivalentents are shown. Others can be calculated by dividing the numerator by the denominator.

1/64 = .0165	7/16 = .4375
1/32 = .0312	1/2 = .500
3/64 = .0468	9/16 = .5625
1/16 = .0625	5/8 = .625
3/32 = .0936	11/16 = .6825
1/8 = .125	3/4 = .750
3/16 = .1875	13/16 = .8125
1/4 = .250	7/8 = .875
5/16 = .3125	15/16 = .9375
3/8 = .3750	

For those who want the best

Ultra-high-frequency triodes

U-H-F oscillator, R.F. amplifier and detector having extremely low capacitances and short leads resulting in efficient operation up to 300 megacycles (1 meter).



HY615 \$2.00 net

Heater.....6.3 volts @ 0.15 ampere
Plate.....300 max. volts & 20 max. ma.
Plate dissipation.....3.5 max. watts
R.F. power output @ 240 mc.
4.0 approx. watts

HY114 \$2.00 net

Low-drain filament-type triode for portable and mobile uses powered from batteries.
Filament.....1.4 volts @ 0.12 ampere
Plate.....180 max. volts & 15 max. ma.

Medium-power triode with cylindrical graphite anode, helical filament, vertical-bar tantalum grid. Provides unusually-high power output with minimum input.

HY75 \$3.75 net

Filament.....6.3 volts @ 2.5 amperes
Plate.....450 max. volts & 100 max. ma.
Plate dissipation.....15 max. watts
Output Modulated Unmodulated
224 Mc.....14.....17.....watts
112 Mc.....19.....24.....watts
56 Mc.....24.....33.....watts



R.F. beam-power tetrodes

R.F. power amplifier, buffer, frequency multiplier, oscillator, Class AB2 modulator of exceptionally high power sensitivity. Fully shielded for R.F. — no neutralizing required.

HY61/807 \$3.50 net

Heater.....6.3 volts @ 0.9 ampere
Plate.....600 max. volts & 100 max. ma.
Plate dissipation.....25 max. watts
R.F. power output.....37.5 approx. watts

HY60 \$2.50 net

Low-power version of HY61 with reduced power drain — Ideal for mobile uses.
Heater.....6.3 volts @ 0.5 ampere
Plate.....425 max. volts & 60 max. ma.



Instant-heating tetrode

Instantaneous-heating filament type R.F. and audio tetrode for mobile and portable xmitters — no battery drain during stand-by. Shielded for R.F. Full plate input for phone and doubler operation. Also operates efficiently on AC.

HY69 \$3.50 net

Filament.....6.3 volts @ 1.5 amperes
Plate.....600 max. volts & 100 max. ma.
Plate dissipation.....40 max. watts
Nominal Class C output.....42 approx. watts



Graphite-anode triodes

High-efficiency SPEER graphite-anode triodes for R.F. Class B and C amplifier, buffer, doubler, oscillator, Class B modulator.



HY51A-HY51B \$4.50 net

HY51A filament.....7.5 volts @ 3.5 amperes
HY51B filament.....10 volts @ 2.25 amperes
Plate.....1000 max. volts & 175 max. ma.
Plate dissipation.....65 max. watts
Class C output at 75% efficiency.....131 watts

HY51Z \$4.50 net

Zero-bias version of HY51A for all applications
Filament.....7.5 volts @ 3.5 amperes
Class C output @ 75% efficiency.....131 watts

HY40 \$3.50 net

Filament.....7.5 volts @ 2.25 amperes
Plate.....1000 max. volts & 115 max. ma.
Plate dissipation.....40 max. watts
Class C output at 75% efficiency.....86 watts

HY40Z \$3.50 net

Zero-bias high-mu triode similar to HY40 in ratings — particularly desirable as modulator.
Filament.....7.5 volts @ 2.5 amperes
Class C output @ 75% efficiency.....86 watts



HY30Z \$2.50 net

A real 25-watt transmitting tube with over-size graphite-anode and lava insulators — definitely not an overgrown receiving tube.

Filament.....6.3 volts @ 2.25 amps.
Plate.....850 max. volts & 90 max. ma.
Plate dissipation.....30 max. watts
Class C output at 75% efficiency
58 watts



Hytron transmitting tubes are fully licensed for protection of the buyer or user.

Mercury-vapor rectifiers

Half-wave mercury-vapor rectifier with internal shield to prevent bombardment of elements.

866 \$1.50 net

Filament.....2.5 volts @ 5 amperes
AC plate voltage.....2650 max. volts
Two Hytron 866's will deliver up to 2385 volts DC at currents up to 500 milliamperes.
Junior rectifier for light-duty applications with plate connection to top cap.

866 Jr. \$1.05 net

Heater.....2.5 volts @ 3.0 amperes
AC plate voltage.....1250 max. volts
DC plate current.....250 max. ma. for two tubes

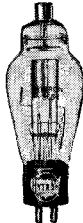

Twin triode

Instant-heating thoriated-tungsten zero-bias twin-triode for use as modulator in mobile transmitters — designed as a companion to the HY69.

HY31Z \$3.50 net

Filament.....6.3 volts @ 2.5 amperes
Plate.....500 max. volts & 150 max. ma.
Plate dissipation.....30 max. watts
Audio power output.....50 watts
Above ratings are for both sections of tube.



Ceramic-base Bantams and 6L6GX

6A8GTX converter.....\$.95 net
6J5GTX med. mu triode.....\$.95 net
6J7GTX r.f. pentode.....\$.95 net
6K7GTX r.f. pentode.....\$.95 net
6K8GTX converter.....\$1.30 net
6SA7GTX converter.....\$1.05 net
6S7GTX r.f. pentode.....\$1.05 net
6SK7GTX.....\$1.05 net
6L6GX.....\$1.25 net

Specially-selected tubes with low-loss ceramic base for use in high-frequency circuits. Interchangeable with metal and G types.



HYTRONIC

A DIVISION OF THE HYTRON CORP



LABORATORIES

70 Lafayette St., Salem, Mass.

THE "Q" SIGNALS

Abbreviation	Question	Answer
QRA	What is the name of your station?	The name of my station is
QRB	How far approximately are you from my station?	The approximate distance between our stations is nautical miles (or kilometers).
QRC	What company (or Government Administration) settles the accounts for your station?	The accounts for my station are settled by the company (or by the Government Administration of).
QRD	Where are you bound and where are you from?	I am bound for from
QRG	Will you tell me my exact frequency (wavelength) in kc/s (or m)?	Your exact frequency (wavelength) is kc/s (or m).
QRH	Does my frequency (wavelength) vary?	Your frequency (wavelength) varies.
QRI	Is my note good?	Your note varies.
QRJ	Do you receive me badly? Are my signals weak?	I cannot receive you. Your signals are too weak.
QRK	Do you receive me well? Are my signals good?	I receive you well. Your signals are good.
QRL	Are you busy?	I am busy (or I am busy with). Please do not interfere.
QRM	Are you being interfered with?	I am being interfered with.
QRN	Are you troubled by atmospherics?	I am troubled by atmospherics.
QRO	Shall I increase power?	Increase power.
QRP	Shall I decrease power?	Decrease power.
QRQ	Shall I send faster?	Send faster (..... words per minute).
QRR	<i>Amateur "SOS" or distress call (U.S.A.). Use only in serious emergency.</i>
QRS	Shall I send more slowly?	Send more slowly (..... words per minute).
QRT	Shall I stop sending?	Stop sending.
QRU	Have you anything for me?	I have nothing for you.
QRV	Are you ready?	I am ready.
QRW	Shall I tell that you are calling him on kc/s (or m)?	Please tell that I am calling him on kc/s (or m).
QRX	Shall I wait? When will you call me again?	Wait (or wait until I have finished communicating with) I will call you at o'clock (or immediately).
QRY	What is my turn?	Your turn is No. (or according to any other method of arranging it).
QRZ	Who is calling me?	You are being called by
QSA	What is the strength of my signals (1 to 5)?	The strength of your signals is (1 to 5).

Quality above all



TRANSMITTING CAPACITORS



SOLAREX — Super-value for Filters



TRANSOIL — for Permanent Filters

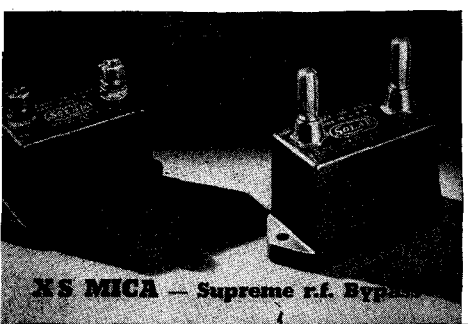

XS MICA — Supreme r.f. By



TRANSMICA — Current-carrying; High Q

SOLAR MFG. CORP. • Bayonne, New Jersey



XM MICA — High Voltage & Stability

Abbreviation	Question	Answer
QSB	Does the strength of my signals vary?	The strength of your signals varies.
QSD	Is my keying correct; are my signals distinct?	Your keying is incorrect; your signals are bad.
QSG	Shall I send telegrams (or one telegram) at a time?	Send telegrams (or one telegram) at a time.
QSJ	What is the charge per word including your internal telegraph charge?	The charge per word for is francs, including my internal telegraph charge.
QSK	Shall I continue with the transmission of all my traffic, I can hear you through my signals?	Continue with the transmission of all your traffic, I will interrupt you if necessary.
QSL	Can you give me acknowledgment of receipt?	I give you acknowledgment of receipt.
QSM	Shall I repeat the last telegram I sent you?	Repeat the last telegram you have sent me.
QSO	Can you communicate with direct (or through the medium of)?	I can communicate with direct (or through the medium of).
QSP	Will you retransmit to free of charge?	I will retransmit to free of charge.
QSR	Has the distress call received from been cleared?	The distress call received from has been cleared by
QSU	Shall I send (or reply) on kc/s (or m) and/or on waves of Type A1, A2, A3, or B?	Send (or reply) on kc/s (or m) and/or on waves of Type A1, A2, A3, or B.
QSV	Shall I send a series of VVV ?	Send a series of VVV
QSW	Will you send on kc/s (or m) and/or on waves of Type A1, A2, A3 or B?	I am going to send (or I will send) on kc/s (or m) and/or on waves of Type A1, A2, A3 or B.
QSX	Will you listen for (call sign) on kc/s (or m)?	I am listening for (call sign) on kc/s (or m).
QSY	Shall I change to transmission on kc/s (or m) without changing the type of wave? or Shall I change to transmission on another wave?	Change to transmission on kc/s (or m) without changing the type of wave.
QSZ	Shall I send each word or group twice?	Change to transmission on another wave.
QTA	Shall I cancel telegram No. as if it had not been sent?	Send each word or group twice.
QTB	Do you agree with my number of words?	Cancel telegram No. as if it had not been sent.
QTC	How many telegrams have you to send?	I do not agree with your number of words; I will repeat the first letter of each word and the first figure of each number.
QTC	How many telegrams have you to send?	I have telegrams for you (or for).

Abbreviation	Question	Answer
QTE	What is my true bearing in relation to you? or What is my true bearing in relation to (call sign)? or	Your true bearing in relation to me is degrees or Your true bearing in relation to (call sign) is degrees at (time) or
	What is the true bearing of (call sign) in relation to (call sign)?	The true bearing of (call sign) in relation to (call sign) is degrees at (time).
QTF	Will you give me the position of my station according to the bearings taken by the direction-finding stations which you control?	The position of your station according to the bearings taken by the direction-finding stations which I control is latitude longitude.
QTG	Will you send your call sign for fifty seconds followed by a dash of ten seconds on kc/s (or m) in order that I may take your bearing?	I will send my call sign for fifty seconds followed by a dash of ten seconds on kc/s (or m) in order that you may take my bearing.
QTH	What is your position in latitude and longitude (or by any other way of showing it)?	My position is latitude longitude (or by any other way of showing it).
QTI	What is your true course?	My true course is degrees.
QTJ	What is your speed?	My speed is knots (or kilometers) per hour.
QTM	Send radioelectric signals and submarine sound signals to enable me to fix my bearing and my distance.	I will send radioelectric signals and submarine sound signals to enable you to fix your bearing and your distance.
QTO	Have you left dock (or port)?	I have just left dock (or port).
QTP	Are you going to enter dock (or port)?	I am going to enter dock (or port).
QTQ	Can you communicate with my station by means of the International Code of Signals?	I am going to communicate with your station by means of the International Code of Signals.
QTR	What is the exact time?	The exact time is
QTU	What are the hours during which your station is open?	My station is open from to
QUA	Have you news of (call sign of the mobile station)?	Here is news of (call sign of the mobile station).
QUB	Can you give me in this order, information concerning: visibility, height of clouds, ground wind for (place of observation)?	Here is the information requested
QUC	What is the last message received by you from (call sign of the mobile station)?	The last message received by me from (call sign of the mobile station) is
QUD	Have you received the urgency signal sent by (call sign of the mobile station)?	I have received the urgency signal sent by (call sign of the mobile station) at (time).

The New 1941 SUPER SKYRIDER SX-28

The Communications receiver with outstanding performance. See the new 1941 Super Sky rider and you will know why Hallicrafters lead in communications equipment value. Contains two stages of preselection—high fidelity, push pull audio—band pass audio filter—calibrated bandsread—micrometer scale on main dial knob. Standard size relay rack panel—cabinet attractively designed.

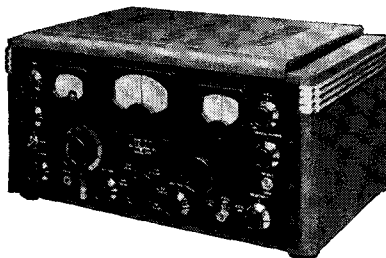

SPECIFICATIONS

Frequency range 540KC to 43MC in 6 bands—15 tubes—14 gauge steel chassis—AF and RF gain—6 position band switch—2 RF stages—80/40/20/10 meter amateur bands calibrated. Cabinet dimensions 20½" x 14½" x 9½". Prices start at \$159.50 Net.

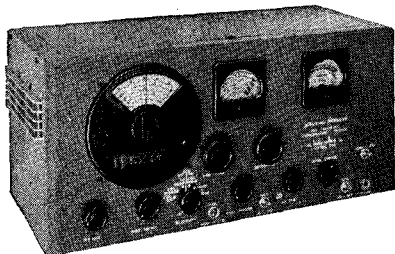

The SKYRIDER DEFIANT • SX-24

Offers performance that can be compared with most receivers at twice the price. All the advanced Hallicrafters' features are incorporated in this unit. Four bands covering from 545 kc. to 43.5 mc. Frequency meter tuning on 10, 20, 40, and 80 meter amateur bands. Controls include R.F. gain, selectivity switch, crystal phasing, audio gain, pitch control, main tuning control, bandsread tuning control, A.N.L. switch, Hi-Lo tone, send-receive switch and BFO switch.

SPECIFICATIONS

One stage preselection—9 tubes—accurately calibrated dial—efficient noise limiter circuit—meter calibrated in both S and DB units—six point variable selectivity from sharp CW crystal to high fidelity. Cabinet size 19½" x 9½" x 10½"—Prices \$69.50 Net.

HT-6. 25 WATT Phone and CW Transmitter

Here is a transmitter that lives up to the Hallicrafters tradition of high quality. Using an 807 in the final stage the power output is 25 watts on most bands. Frequency range is 1.7 mc. to 60 mc. Coils for any 3 bands may be plugged in, pretuned, and then switched at will by a front panel control connecting all circuits from crystal to antenna. It is necessary only to retune the final amplifier plate. Coils available for any amateur band, 5 to 160 meters with crystal control; or with ECO on the 160, 80, 40, 20 meter amateur bands.

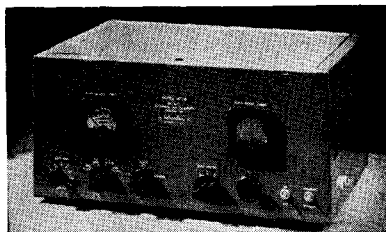

SPECIFICATIONS

8 tubes—Power drain about 120 watts CW and 225 watts phone. Dimensions 20" x 9" x 15". For operation on 110 volts 50-60 cycle AC. Price \$99.00 Net.

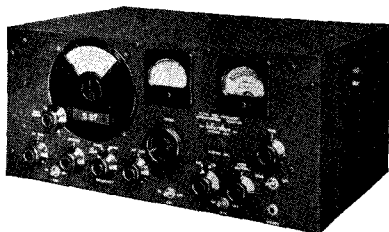

FM/AM 145 MC-27MC • S-27

The first general-coverage U.H.F. communications receiver to incorporate Frequency modulation reception. Covers 3 bands; Switch changing from FM to AM reception. IF selectivity automatically sharpened to receive amplitude modulated U.H.F. signals or broadened for wide band frequency modulated signals.

SPECIFICATIONS

15 tubes—Coverage 27 to 46 mc., 45 to 84 mc., 81 to 145 mc. on 3 bands—Acorn tubes in R.F. and converter system—High gain 1852 tubes in Iron Core I.F. stages—beam power tubes in A.F. Amplifier. Cabinet size 19" x 9" x 14". Price \$175.

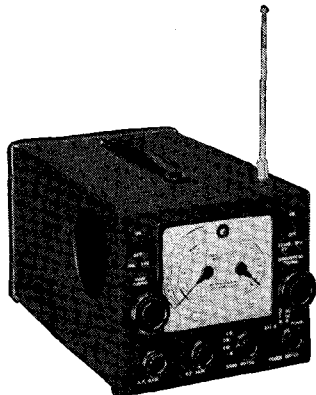

S-29 SKY TRAVELLER

For use at home or when traveling—truly a universal receiver. Operates on 110 Volt AC or DC or from self-contained batteries. Designed for the greatest rigidity consistent with the least weight. Self-contained antenna with high gain coupling circuit provides exceptional reception. One stage of preselection on all bands. Bandspreading is electrical. Automatic noise limiter.

The S-29 Sky Traveller portable is engineered to communication receiver tolerances. Mounted in an attractive black crackle finished aluminum cabinet with rounded corners. The Receiver covers from 542 kc. to 30.5 mc. (553 to 9.85 meters) on 4 bands. 1.4 volt tubes used throughout. Neon lamp indicates when tubes are lighted. Controls include, Main tuning, Bandspread, R.F. Gain, A.F. Gain, Band switch, AVC off-on switch, BFO off-on Switch, ANL off-on switch, Send-receive—Standby Switch. Connectors are Doublet antenna Socket, Long Antenna Socket, Phone Jack, AC/DC Cable with plugs.

SPECIFICATIONS

9 tubes—Automatic noise limiter—RF Stage used on all bands—Approx. battery life 100 hours—Permea-

bility tuned RF and IF circuits—cabinet size 7" x 8½" x 13¼". Price \$59.50.

The SKY CHAMPION S-20R

Offers a quality of performance never before equalled at this low price. A communications receiver with preselection and built-in speaker. Has all of the essential controls for good amateur reception as follows: FR gain, tone control, phone jack, AVC switch, BFO switch, send-receive switch, audio gain, pitch control and 4-position band switch. Easily adapted to 6 volt operation with a Model No. 301 Electronic Converter.

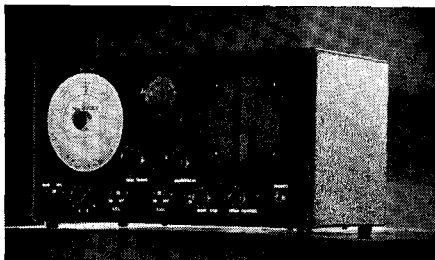

SPECIFICATIONS

9 tubes—Automatic noise limited—RF Stage used on ertia tuning. Separate electrical bandspread. Beat frequency oscillator. Battery-vibrapack DC oper-

ation socket. Cabinet size—18½" long, 8½" high, 9¾" deep. Price \$49.50 Net.

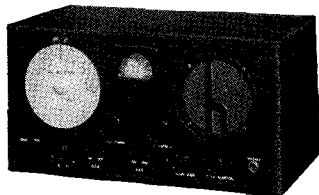

The SKY BUDDY · S-19R

The new 1941 SKY BUDDY is an amateur receiver in every respect, covering everything on the air from 44 mc. to 545 kc., including the 10, 20, 40, 80 and 160 meter amateur bands. It now employs the same electrical bandspread system used in higher priced Hallicrafters models. The more important features are: Electrical bandspread, broadcast Band, BFO, AVC switch, phone jack, pitch control, built-in speaker. For operation on 110 volts 50-60 cycles AC. For operation on 110 volt AC from 6 volt DC use No. 301 Electronic Converter.

SPECIFICATIONS

Six tubes. Tunes 10 meter band. Electrical band-spread. Coverage and bandspread from 545 kc. to

44 mc. DC operation socket—battery or vibrapack. Dimensions 17½" x 8½" x 8½".

The New SUPER DEFIANT · SX-25

Acclaimed by amateurs as the finest receiver ever developed at this moderate price. Outstanding advantages are extreme selectivity, more and better audio and effortless tuning. The general circuit is based on the proved efficiency of America's best selling receiver, the SKYRIDER DEFIANT.

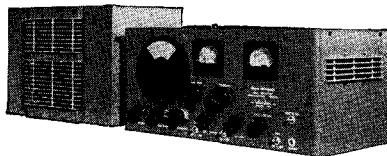

SPECIFICATIONS

12 tubes—2 stages preselection—Band coverage 540 kc. to 42 mc.—4 bands—10" heavy duty PM dynamic speaker—Automatic noise limiter—Push-pull output

stage furnishes 8 watts of audio—Dimensions 19½" x 9½" x 11½". Price \$99.50 Net.

**Abbr-
viation**

Question

Answer

QUF

Have you received the distress signal sent by (call sign of the mobile station)?

I have received the distress signal sent by (call sign of the mobile station) at (time).

QUG

Are you being forced to alight in the sea (or to land)?

I am forced to alight (or land) at (place).

QUH

Will you indicate the present barometric pressure at sea level?

The present barometric pressure at sea level is (units).

QUJ

Will you indicate the true course for me to follow, with no wind, to make for you?

The true course for you to follow, with no wind, to make for me is degrees at (time).

RADIO SYMBOLS USED IN CIRCUIT DIAGRAMS

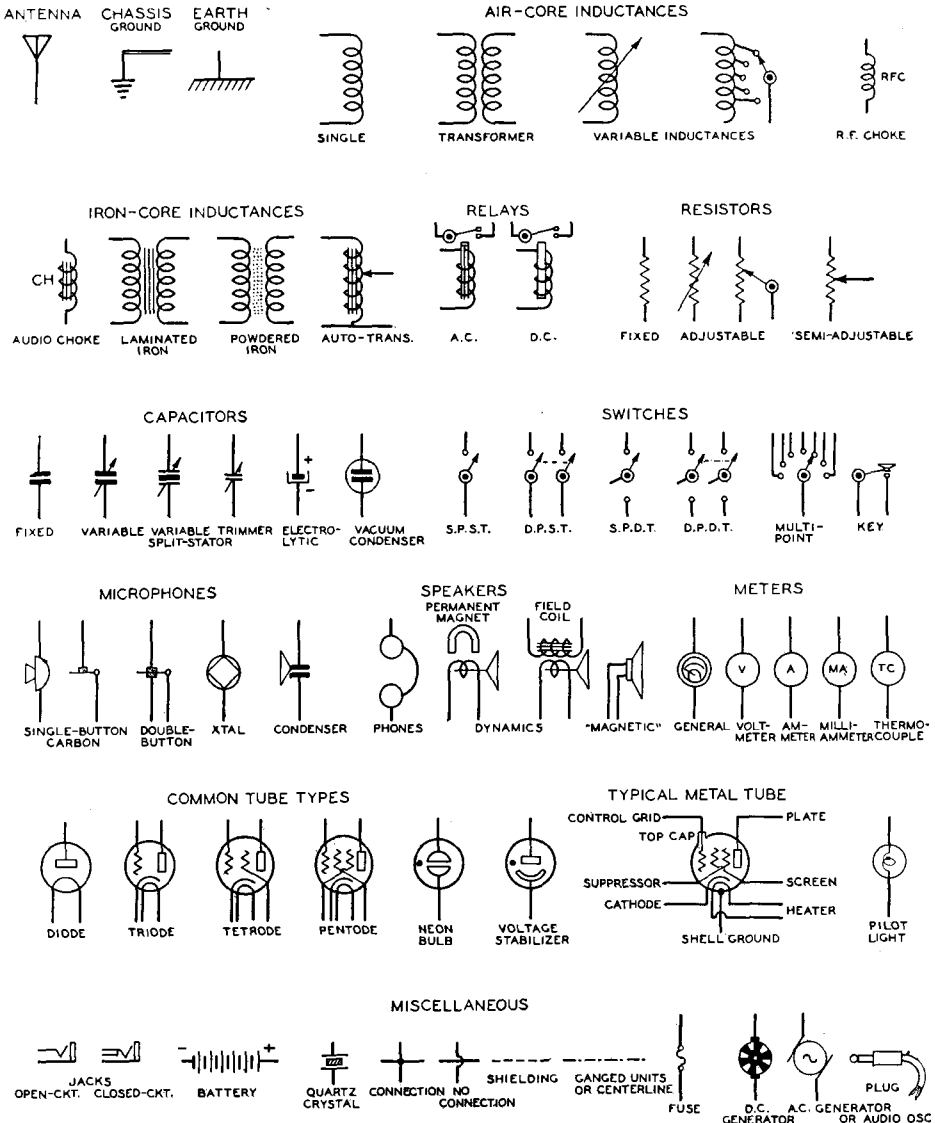

ARTIFICIAL RESPIRATION

By the Prone Pressure Method

(ILLUSTRATIONS COURTESY OF NATIONAL SAFETY COUNCIL, CHICAGO)

The following is the accepted, standardized technique of "How to Give Artificial Respiration by the Prone Pressure Method," agreed upon by a special committee of national organizations and persons appointed by the United States Public Health Service of the Treasury Department.

The Prone Pressure Method of artificial respiration described in these rules should be used in cases of suspended respiration from all causes—drowning, *electric shock*, carbon monoxide poisoning, injuries, etc. Delay of even one minute in the application of the method may lose a life. Follow the instructions even if the patient appears dead. Continue artificial respiration until natural breathing is restored or until a physician declares rigor mortis (stiffening of the body) has set in. Success has come after three and one half hours of effort.

Learn this method now. Don't wait for an accident. Practice on a friend. Let him practice on you.

1. Lay the patient on his belly, one arm extended directly overhead, the other arm bent at elbow and with the face turned outward and resting on hand or forearm so that the nose and mouth are free for breathing. (See figure 1.)

2. Kneel straddling the patient's thighs with your knees placed at such a distance from the hip bones as will allow you to assume the position shown in figure 1.

Place the palms of the hands on the small of the back with fingers resting on the ribs, the little finger just touching the lowest rib, with the thumb and fingers in a natural position, and the tips of the fingers just out of sight. (See figure 1.)

3. With arms held straight, swing forward slowly so that the weight of your body is gradually brought to bear upon the patient. The shoulder should be directly over the heel of the hand at the end of the forward swing. (See figure 2.) Do not bend your elbows. This operation should take about two seconds.

4. Now immediately swing backward so as to completely remove the pressure, thus returning to the position in figure 3.

5. After two seconds, swing forward again. Thus repeat deliberately twelve to fifteen times a minute the double movement of compression and release, a complete respiration in four or five seconds.

6. Continue artificial respiration without interruption until natural breathing is restored if necessary, four hours or longer, or until a physician declares the patient is dead.

7. As soon as this artificial respiration has been started and while it is being continued, an assistant should loosen any tight clothing about the patient's neck, chest, or waist. Keep the patient warm. Do not give any liquids whatever by mouth until the patient is fully conscious.

8. To avoid strain on the heart when the patient revives, he should be kept lying down and not allowed to stand or sit up. If the doctor has not arrived by the time the patient has revived, he should be given some stimulant, such as one teaspoonful of aromatic spirits of ammonia in a small glass of water or a hot drink of coffee or tea, etc. The patient should be kept warm.

9. Resuscitation should be carried on at the nearest possible point to where the patient received his injuries. He should not be moved from this point until he is breathing normally of his own volition and then moved only in a lying position. Should it be necessary, due to extreme weather conditions, etc., to move the patient before he is breathing normally, resuscitation should be carried on during the time he is being moved, if practicable.

10. A brief return of natural respiration is not a certain indication for stopping the resuscitation. Not infrequently the patient, after a temporary recovery of respiration, stops breathing again. The patient must be watched and if natural breathing stops, artificial respiration should be resumed at once.

11. In carrying out resuscitation it may be necessary to change the operator. This change must be made without losing the rhythm of respiration. By this procedure no confusion results at the time of change of operator and a regular rhythm is kept up.



FIGURE 1



FIGURE 2



FIGURE 3

RADIO TELEGRAPH APPARATUS *Manufactured by*

WORLD'S CHAMPION RADIO TELEGRAPHER



• The Amazing **OSCILLATONE**

More than 10,000 oscillators built for operators during the past four years and one improvement after another has finally culminated in a genuine masterpiece.

- Beautiful plastic cabinet developed by the same artist who designed the

Truly an outstanding piece of equipment that belongs on every operator's desk.

MODEL No. 5700 — NET TO THE OPERATOR **\$5.95**

MINUS TUBE
Uses 117N7GT

OSCILLAFONE MODEL No. CR-700 @ \$2.85 net to the operator. An exceptionally fine quality speaker designed expressly for key-clickless dots and dashes. Housed in this same pretty plastic cabinet.

"Super Stream-speed."

- AC-DC operation.
- Complete with built-in reproducer.
- Toggle switch gives choice of low or high volume.
- Choice of 600 or 1000 cycle note.

AC-DC AUDIO OSCILLATOR

MODEL No. A-700
Net to Operator **\$2.85**
Minus Tube
Uses 117N7GT

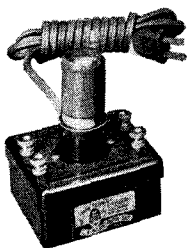

An oscillator fully as good as my amazingly good Oscillatone, except smaller housing because no speaker. Electronically keyed which means limitless speed and clean keying. Uses 110 to 120 volts, either AC or DC. Connect jumper wire across two rear terminals for speaker volume. Terminals: 2 right for key; 2 left for headphones.

Please don't be misled by this absurdly low price. You cannot buy a better audio oscillator for any amount of money.

Battery Powered AUDIO OSCILLATOR

MODEL No. B-700
Net to Operator **\$1.80**
Minus Tube & Batteries
Uses 1Q5GT

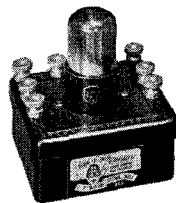

Same pretty plastic cabinet as Model A-700. A remarkably good audio oscillator giving a beautiful clear 1000 cycle note. Uses 1½ volt for A battery and 22½ volts or 45 volts B battery depending upon volume desired. Terminals: 2 right for key; 2 left for phones or speaker. Rear terminals, left to right: B plus, B minus; A plus, A minus. Here is really an exceptionally fine piece of battery operated equipment. No more headaches from squawky buzzers.

AUTOMATIC EQUIPMENT for TRANSMITTING and RECEIVING

Write for separate sheet describing Mac's astounding device which automatically keys local oscillator or another transmitter on the incoming signal. It is positively amazing! RETRANSMITTER, Model No. 1400 \$60.00 net to operator complete, nothing else to buy.

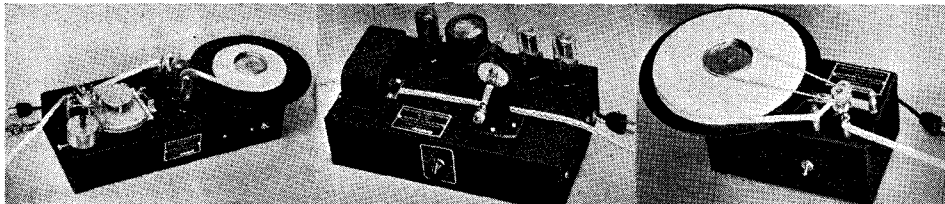

MAC RECORDER

A commercial quality radio telegraph signal recorder capable of speeds in excess of 200 wpm. Sold only as complete unit with RECORDER DRIVING UNIT which is a signal leveler, noise suppressor and static eliminator. Separate folder available.

MODEL No. R-900 **\$29.50**
Driver, RD-900 **\$29.50**

MAC AUTO

Four years of constantly building and improving automatic radio-telegraph transmitters, has resulted in this fine piece of commercial quality apparatus. Uses the new 117N7GT and 117Z6GT type tubes and the RCA 923 photo-tube. Good for 200 wpm. Uses ordinary commercial inked slip. Separate folder available.

MODEL No. PCT811A **\$29.50**

TAPE PULLER

Probably no one has devoted the time, energy and money that Mac has to develop a real high quality commercial type tape puller at a reasonable price. Powerful AC-DC motor with rheostat speed control. Built-in take up reel. Separate folder available.

MODEL No. CTP1300 **\$29.50**

T.R. McElroy



100 BROOKLINE AVENUE

BOSTON, MASS.

RADIO TELEGRAPH APPARATUS *Manufactured by*

WORLD'S CHAMPION RADIO TELEGRAPHER

NEW SUPER STREAM-SPEED

S-600-PC **\$11.85**
Platinum Contacts
 S-600-SC **9.50**
Silver Contacts

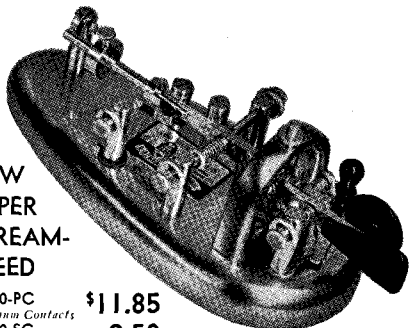

Into this gorgeous speed key has gone Mac's 30 years operating experience supplemented by the finest engineering ability in the radio-telegraph industry... with their combined efforts coordinated under the styling genius of one of America's outstanding design artists. See it! Handle it! You'll have to own it!

PROFESSIONAL MODEL, MAC KEY

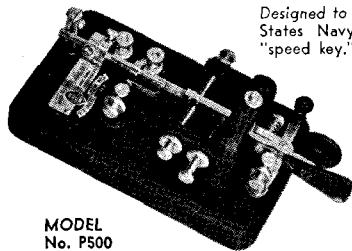

MODEL No. P500
\$7.50

NET TO THE OPERATOR

Designed to conform with United States Navy specifications for "speed key." It is just what its name implies: A fine Professional Operator's model Mac Key. Base $3\frac{3}{4}'' \times 6\frac{1}{2}'' \times \frac{3}{4}''$ thickness. Beautifully black wrinkled over Parkerized base casting. Carefully designed super-structure, similarly finished.

Chromed parts, circuit closer, bakelite insulation, $\frac{3}{16}''$ silver contacts. A key that will thrill any radio or telegraph operator.

AMATEUR MODEL, SPEED KEY

A speed key of this quality is available at this ridiculously low price only because Mac has written off all original production costs, such as patterns, jigs, dies, tools, etc., resulting from tremendous volume on the old style Standard and Deluxe Mac Key over the past five years. Nearly ten thousand of these excellent speed keys have been sold. Black wrinkled base, nickel-plated parts, no circuit closer. Here is a good speed key for the man who must watch costs, but wants a real operator's instrument.

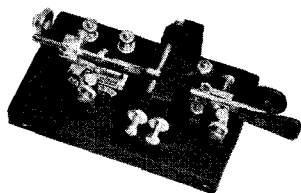

MODEL No. A400
\$5.95 NET TO THE OPERATOR

Combining beauty and utility in a most striking fashion, this radically new, semi-automatic key is the last word in operating ease. Fast, rhythmic Morse is a real pleasure with this key.

- Streamlined base of special dense alloy, Wt. 4 lbs.
- Tear-drop shaped base makes it immovable on table.
- Heavily chromed with bluish tinge to prevent glare.
- Stainless steel coil springs and bearings.
- Beryllium copper mainspring and U spring.
- Bronze bearing screws.
- Bronze alloy pigtail.
- Bakelite insulation throughout.
- Molded plastic dot paddle and dash button.

DELUXE MODEL, STREAMKEY

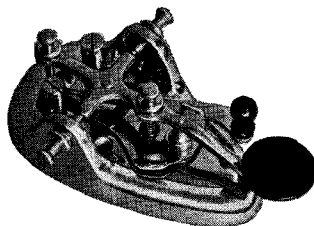

MODELS BB-300,
 or BS-300, price
\$2.85
 NET TO THE OPERATOR

Beautiful tear-drop streamlined base with same extra heavy, bluish tinged chrome finish used on the Super Stream-speed. All parts similarly chromed. Finely balanced and attractive key lever. Huge $\frac{3}{16}''$ contacts especially designed for these keys. There is a "feel" to these streamlined keys that'll thrill any operator! Choice of ball bearings balanced lever, model BB-300; or bronze bearing screws, model BS-300. Same price.

PROFESSIONAL MODEL, STREAMKEY

NET TO THE OPERATOR **\$1.80**

Same key as Deluxe Model, but with black wrinkled base. Choice of ball bearings balanced lever, Model BB-200; or bronze bearing screws, Model BS-200, same price.

AMATEUR STREAM KEY

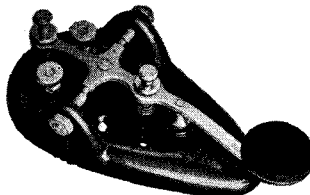

Price, net to Operator
 A-100 @ \$1.00
 S-100 @ \$1.35

Choice of either grey or black plastic. Cadmium parts. Here is a truly fine hand key at a ridiculously low price. A100 minus switch & speed key lip. S100 with switch & speed key lip.

T.R. McElroy



100 BROOKLINE AVENUE

BOSTON, MASS.

STUDY GUIDE

Class B and Class A Amateur License Examinations

The Federal Communications Commission has prepared a reservoir of some several hundred questions for the amateur examination. After you have successfully passed your code test, a group of these questions will be selected from the reservoir and you must make a grade of 75 per cent or higher; otherwise you must wait at least two months from the date of the examination and attempt the examination again.

The questions are changed from time to time to keep pace with revisions in the regulations and with technical progress. However, the applicant can be sure of receiving one question from each of the following ten general classes: Transmitter Theory; Transmitter Practice; Radiotelephony; Power Supplies; Frequency Measurement; Treaty and Laws; F.C.C. Regulations, Bands; F.C.C. Regulations, Part I; F.C.C. Regulations, Part II; Penalties.

The following paraphrased questions are representative of the scope of the questions contained in the amateur radio operators license examination and embrace radio theory, practice, laws and regulations with which the applicants for, and the holders of amateur radio operators licenses should be familiar.

The answers given here are not *necessarily* the *only* correct answers, especially as regards the technical questions. Neither do we guarantee that all of the answers given would command a "100% correct" grading from the Commission, because on some questions it may be a matter of opinion as to whether a certain answer is 100% correct or just "substantially correct." You may be assured, however, that if you can answer all of the questions given here and have a pretty good idea as to why each answer is correct, you need have no fear of failing to make a passing grade.

If you have difficulty in understanding why the answer to a particular technical question

is correct, more study of the theory applying to that question is indicated.

The actual questions as given in the examination will appear in the short answer form such as multiple choice or simple diagrams and computations, etc.

Class B Study Guide

1. Name the basic units of electrical resistance, inductance, capacitance, current, electromotive force or potential difference, power, energy, quantity, magnetomotive force, and frequency.

Basic Units: Resistance—ohms; Inductance—henry; Capacitance—farad; Current—ampere; Electromotive Force or Potential Difference—volt; Power—watt; Energy—joule; Quantity—coulomb; Magnetomotive Force—gilbert; Frequency—cycles per second.

2. Name the instruments normally used to measure:

- (a) electric current
- (b) potential difference
- (c) power
- (d) resistance
- (e) frequency
 - (a) Ammeter
 - (b) voltmeter
 - (c) Wattmeter
 - (d) ohmmeter
 - (e) frequency meter or wave meter.

3. How may plate power input of an amplifier be determined when the plate voltage and plate current are known?

Plate power input may be determined by applying the power formula, $P = EI$ (or $W = EI$), which means that the power equals the product of voltage in volts and the current in amperes.

4. Explain the purpose of using a center-tap return connection on the secondary of a transmitting tube's filament transformer.

The effective (average) potential of the filament of a filamentary type tube with respect to the grid and plate is the same as the potential at the exact center of the filament. When using alternating current to

The FCC cannot answer inquiries from candidates who have taken an examination as to what grade they made, or what was the matter with their answers if they did not pass. The large number of candidates makes this impossible.

THE RECEIVER BUY OF THE SEASON!

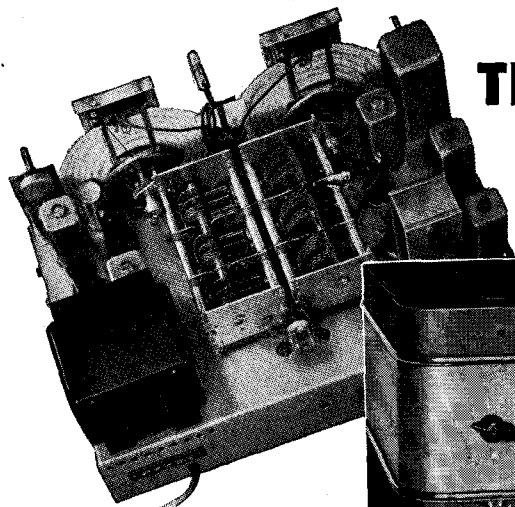

AR-77 COMMUNICATION RECEIVER

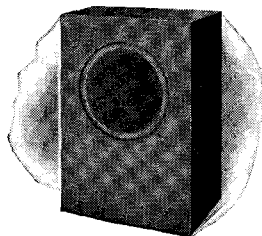

Double-Purpose Value

During off periods of "QSO-ing", when you are busy experimenting or just relaxing, you will want some good entertainment programs. To meet this extra requirement, we offer a new Extended Range Loudspeaker MI-8314-A for the AR-77. A combination hard to beat for faithful reproduction of all modulated signals. Dimensions of the MI-8314-A Speaker are: 28" high, 18 7/8" wide, 13" deep.

Amateurs' Net Price for both AR-77 Receiver and MI-8314-A Speaker \$154.50

"STAY-PUT" TUNING

Tests under average conditions show maximum drift at 30 Mc to be only 3.0 Kc on one hour run, thereby keeping signal audible.

ADJUSTABLE NOISE LIMITER

Can easily be regulated to meet local conditions. Easily understood signals obtained through noise peaks hundreds of times higher than signal level.

"BREAK-IN" OPERATION

Used on a separate antenna, receiver recovers instantly when transmitter key is up. Ideal for "traffic hounds" to move a hook full of messages promptly. (Receiving antenna should resonate in higher frequency band than transmitter frequency to prevent excessive voltage pick-up from transmitter.)

HIGHEST SIGNAL-TO-NOISE RATIO

A 2-to-1 ratio of signal-to-noise is obtained at an average sensitivity of 2 microvolts throughout range.

UNIFORM SENSITIVITY

Each r-f circuit has dual alignment with air-dielectric trimmers for high-frequency end and inductance adjustment of coils for low end.

BANDSPREAD TUNING

Calibrated bandspread for 10, 20, 40, and 80-meter bands extends to nearly full rotation of dial for "split-kilocycle" readings. Carrier level meter serves for both peak tuning and to measure signal strength in popular "S" scale.

6-STEP SELECTIVITY

Wide choice of selectivity assures operator control of signal interference.

IMPROVED IMAGE REJECTION

Image ratio of approximately 40-1 at 30 Mc is obtainable.

NEGATIVE FEEDBACK

Smooths out and extends the audio response curve.

Give it a Whirl! Other AR-77 features include Uniview dials; accurate signal reset; standby switch with relay terminals; temperature and voltage compensated oscillator; high-gain pre-selector stage and a popular tuning range of 540 to 31,000 Kc. Write for Bulletin. Amateurs' Net Price \$139.50. MI-8303 Table Speaker in matched cabinet \$8.00 extra. All prices f. o. b. factory.



for Performance Plus

RCA MANUFACTURING COMPANY, INC., Amateur Division, CAMDEN, N. J. • A Service of the Radio Corporation of America

heat the filament of the tube, there will be a small A.C. voltage impressed upon the grid unless the return is made to the exact center tap.

5. If the high-voltage secondary of a plate transformer was changed from a full-wave center-tapped to a bridge rectifier connection, what would be the relative voltage and current output ratings as compared to those for the full-wave center-tapped connection?

Changing from a full-wave center-tapped to a bridge rectifier would double the power supply output voltage and cut the permissible current in half.

6. Why is it advisable to use a plate power supply for the oscillator of a transmitter separate from the final amplifier plate power supply?

To prevent final amplifier power supply voltage variations, such as might be caused during keying or modulation, from being applied to the oscillator and causing undesired frequency modulation.

7. How does a swinging choke operate to improve the voltage regulation of a plate supply filter system?

Its inductance, and hence the voltage drop across it, decreases considerably with increasing load. The high inductance at low values of current prevents soaring of the output voltage at light loads.

8. Why is full-wave rectification generally preferable to half-wave rectification in a power supply?

A full-wave rectifier supplies twice as many pulses per second to the filter, for a given supply frequency, and therefore is easier to filter and provides better voltage regulation.

9. What are the relative advantages and disadvantages of mercury-vapor and high-vacuum rectifiers of equivalent filament ratings?

A mercury-vapor rectifier has lower internal resistance than the high-vacuum rectifier, and will therefore usually supply more voltage to the filter under load (for a given transformer voltage). Because of its lower internal resistance, the mercury-vapor rectifier is more likely to be damaged from accidental overload or short circuiting. Mercury-vapor rectifiers sometimes cause "hash" to be generated because of transient oscillations set up each time the mercury vapor becomes ionized.

10. What are the principal output voltage ripple frequencies with half-wave and full-wave single-phase rectifiers, in terms of the a.c. supply frequency?

With a half-wave rectifier the principle output ripple frequency is equal to the supply-voltage frequency; with a full-wave rectifier it is equal to twice the supply-voltage frequency.

11. What is the principal reason for using a filter in a plate power supply system?

The filter in a power supply is used to smooth out the irregularities or "ripple" in the rectified alternating current, thus delivering a pure, unvarying voltage to the load circuit.

12. What would be a suitable type and the approximate capacitance of the filter condensers in a typical 1000-volt transmitter plate supply system?

With a choke-input, two-section filter, the first condenser should be at least a 2- μ fd. unit and the second 4- μ fd., if the power supply is to be used on a plate-modulated stage. With a radiotelegraph transmitter, the second condenser could be reduced to 2- μ fd. The condensers preferably should be of the oil-filled paper type and rated at 1500 volts d.c. working voltage.

13. What would be the visible operating results of a short-circuited filter condenser in a plate power supply with an unfused primary circuit?

The first result would be a much more intense glow in mercury-vapor rectifiers or extremely high plate dissipation (as indicated by the plate becoming red hot) with high-vacuum type rectifier tubes.

14. Why should a fuse be used in the transformer primary circuit of a power supply system?

To prevent the damaging of power supply components in case of a short circuit in the power supply and to guard against the possibility of fire by preventing the power-supply components from becoming overheated in case of such a short circuit.

15. Why is a bleeder resistor connected across the output circuit of a high-voltage power supply system?

To improve the voltage regulation by keeping a small load on the power supply at all times when it is turned on and to provide a load which will discharge the filter condensers in cases where the power supply is turned off when no external load is connected.

16. What would happen if the primary of a 60-cycle power supply was connected to mains carrying continuous direct current?

The fuse would probably blow, if the primary were fused. Otherwise the primary or primaries of the transformers in the power supply would soon be burned out.

17. What is the principal advantage of a screen-grid type R.F. amplifier tube over a triode of equal output rating?

The screen-grid type tube required no neutralization when used in a properly designed r.f. amplifier stage.

18. What tube rating indicates the maximum safe heat radiation capability of the anode of a vacuum tube?

The plate dissipation rating.

19. In the classification of tubes according to the number of elements, how many grids

GAMMATRON

NOW IN ITS 13th YEAR

Heintz and Kaufman made the first Tantalum tube 13 years ago. Now every major vacuum tube manufacturer has followed the lead of GAMMATRON. Because Heintz and Kaufman engineers pioneered Tantalum tubes, they are today's leaders in this field. For maximum performance, reliability and life go GAMMATRON today! Condensed characteristics are shown in the table below.

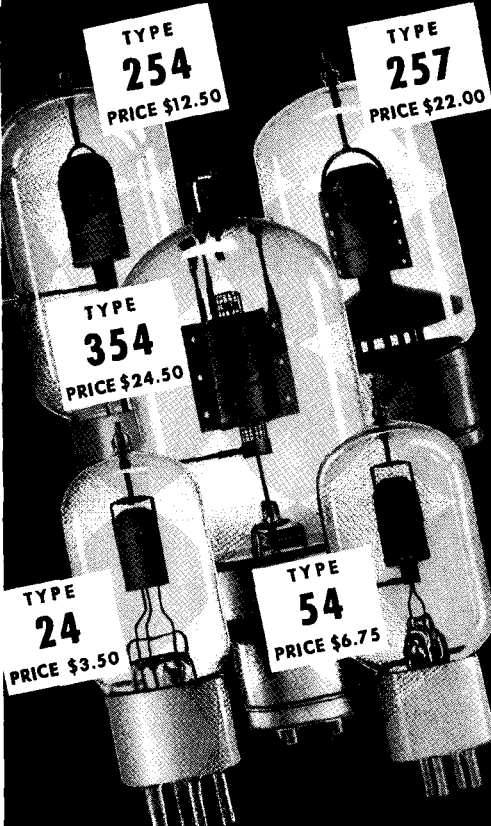

TUBE TYPE NO.	24	54	254	257	354A*	354C	354D	354E	354F	654	1054	1554	279-A 2054-A	3054
MAXIMUM POWER OUTPUT: Single Class Tube 'C' R.F.	89	210	450	230	700	750	700	700	700	1400	3000	4000	2000	5300
MAXIMUM POWER OUTPUT: Two Tubes Class 'B' Audio (2½% Harmonic Distortion)	125	200	450	...	630	650	690	690	725	1350	3500	4500	4000	7000
C.C. BROADCAST RATINGS: High Level Modulation	50	100	...	250	250	250	250	250	500	...	1000	750	2500
Low Level Modulation	50	50	50	50	50	125	...	250	500	500
Grid Modulation	50	50	100	...	250	...	500
NORMAL PLATE DIS.: Watts	25	50	100	75	150	150	150	150	150	300	750	1000	1000	1500
AVER. AMP. CONSTANT	25	27	25	...	9	14	22	35	50	22	13.5	14.5	10	20
MAXIMUM RATINGS: Plate Volts	2000	3000	4000	4000	4000	4000	4000	4000	4000	4000	6000	6000	3000	5000
Plate M.A.	75	150	200	150	300	300	300	300	300	600	1000	1300	800	2000
Grid M.A.	30	30	40	25	50	50	55	60	75	100	125	250	200	500
FILAMENT: Volts	6.3	5.0	5.0	5.0	5.0	5.0	5.0	5.0	5.0	7.5	7.5	11.0	10.0	14.0
Ampères	3.0	5	7.5	7.5	10	10	10	10	10	15	22	22	22	45
MAXIMUM FREQUENCY: Full Ratings, Mc.	100	100	50	50	30	30	30	30	30	20	15	15	15	15
INTERELECTRODE CAP.: C g-p u.u.f.	1.7	1.9	3.4	0.04	4	4	4	4	4	5.5	4.5	11	18	15
C g-f u.u.f.	2.5	1.9	3.3	13.8	9	9	9	9	9	6.2	6.0	15.5	15	25
C p-f u.u.f.	0.4	0.2	1.1	6.7	1	1	1	1	1	1.5	.8	1.2	7	2.5
PHYSICAL: Length, inches	4¾ 1½	5¾ 2	7¼ 2½	6¾ 2½	8¼ 3	8¼ 3	8¼ 3	8¼ 3	8¼ 3	10¾ 4	16½ 6	18 6	21½ 6	30¾ 9
Diameter, inches	Small UX 1¼	STD. UX 2½	50 Watt 6½	GIANT 7 PIN	50 Watt 9	50 Watt 9	50 Watt 9	50 Watt 9	50 Watt 9	50 Watt 14	Special 45	HK255 56	W.E.Co. 66	HK255 200
Base														
Weight, oz.														
NET PRICE	\$3.50	\$6.75	\$12.50	\$22.00	\$24.50	\$24.50	\$24.50	\$24.50	\$24.50	\$75.00	\$175.00	\$225.00	\$300.00	\$395.00

*Type 354 is supplied in either high frequency style (grid terminal on side of envelope) or standard style (grid terminal on base).

WRITE FOR FULL DATA ON GAMMATRON
ENGINEERED TANTALUM TUBES.....



has each of the following types:

- (a) diode
 - (b) triode
 - (c) tetrode
 - (d) pentode
 - (e) heptode?
- (a) none
 - (b) one
 - (c) two
 - (d) three
 - (e) five

20. Describe the adjustment procedure for proper neutralization in a radio-frequency power amplifier using an r.f. indicator coupled to the plate tank circuit.

First the plate voltage lead is disconnected. With excitation applied to the stage to be neutralized and the plate circuit tuned to resonance as shown by the indicator being used, the neutralizing adjustment should be varied until the neutralizing indicator shows zero output in the amplifier plate circuit. The plate and grid circuits should be kept tuned to resonance while the neutralizing adjustment is varied.

21. Why is it necessary to neutralize a triode radio-frequency power amplifier operating with input and output circuits tuned to the same frequency?

To prevent feedback of r.f. energy from the plate to grid through the plate-to-grid capacity of the tube. Feedback may cause the tube to self-oscillate.

22. What undesirable effects may result from operation of an unneutralized triode r.f. amplifier in a transmitter?

The stage may oscillate and thus cause spurious interfering signals to be generated. If the stage is modulated the spurious signals may change frequency and strength during modulation, thus causing interference over a wide band of frequencies. Improper neutralization of a modulated stage may also cause the signal to be badly distorted even though the stage does not self-oscillate at any time.

23. What undesirable effects result from frequency modulation of an amplitude-modulated carrier wave?

Spurious signals which occupy a wide band of frequencies and cause unnecessary interference may be transmitted.

24. What operating conditions would be favorable for harmonic generation in a radio-frequency doubler or frequency multiplying amplifier?

High bias, high excitation, and a sharply peaked exciting waveform are conducive to the generation of harmonics. A single-ended stage is a better generator of even harmonics than a push-pull stage. Likewise a high mu tube is a better frequency multiplier than a low mu tube, and a tetrode or pentode a better harmonic generator than a triode.

25. Where is link coupling applicable in an oscillator-amplifier type transmitter?

Between the plate tank of the oscillator and the grid tank of the amplifier (or between any two stages.) Between the amplifier plate tank and the antenna tuning or matching tank.

26. What is the purpose of a Faraday (electrostatic shield) between the output circuit of an r.f. power amplifier and antenna coupling system?

To minimize electrostatic coupling to the antenna and thus prevent harmonics from reaching the antenna by this means.

27. What are the output circuit conditions for obtaining optimum power output from a radio-frequency amplifier?

The output tank circuit should have sufficient "Q" that maximum output occurs at the point of minimum plate current. The output tank should be operated at exact resonance. The amplifier should work into the proper value of non-reactive load.

28. In which stage of a transmitter is an amplifier of high harmonic output least desirable?

In the stage that feeds the antenna.

29. What are the relative plate current indications for resonance and off-resonance running of the plate tank circuit of a radio-frequency power amplifier?

When the stage is properly designed and loaded, or is running unloaded, resonance occurs at the point of minimum plate current. Off resonance the current is quite high.

30. What are the advantages of a push-pull r.f. power amplifier output stage as compared to a single-ended stage of the same power?

The push-pull stage is easier to neutralize at high frequencies, requires less "Q" or tuning capacity in the plate tank circuit, and has much lower even harmonic output (2d, 4th, etc.).

31. In the circuit diagram (left) what is the value of the bias voltage? What is the value of the bleeder resistance, R_2 ?

Bias voltage equals 3 volts (10 ma. or 01. amp. through 300 ohms). R_2 is equal to the plate voltage E divided by .005 (amp).

32. A certain 1750-kc. Y-cut quartz crystal has a positive temperature coefficient of 125 cycles per degree Centigrade and is started in operation at 40 degrees Centigrade. If the temperature-frequency characteristic is linear, what will the oscillation frequency be at a temperature of 60 degrees Centigrade?

1752.5 kc.

Note: A positive temperature coefficient means that the crystal drifts higher in frequency with an increase in temperature.

33. A 2000-kc. low-drift crystal having a negative temperature coefficient of 5 cycles per megacycle per degree Centigrade is started in operation at 40 degrees Centigrade. If the temperature-frequency characteristic

STOP GUESSING! SPRAGUE PLAY SAFE!

1 Sizes
1 Shapes
1 Voltages

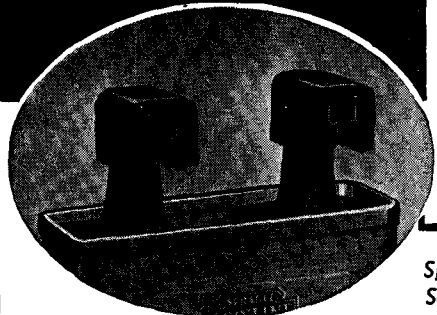
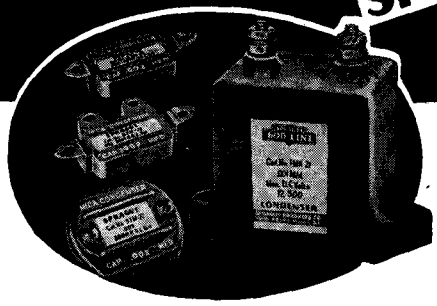

Sprague Lifeguard Safety Caps FREE.

NEW SPRAGUE HIGH VOLTAGE MICAS

You don't have to go looking with a microscope for voltage markings on Sprague High Voltage Mica Condensers! Each voltage has a different colored label for quick and positive identification—red for 5,000 volt condensers, blue for 2,500 volt and green for 1,000 volts. Condensers are molded in moisture-proof, low-loss bakelite, while the extremely high voltage units are sealed in non-hygroscopic porcelain.

You're sure the voltage is right. You know from past experience that Sprague quality cannot be surpassed.

Lifeguard Safety Caps for exposed condenser terminals are only one of four outstanding safety features that make Sprague Transmitting Condensers (round or rectangular types) tops for any amateur need. Terminals are perfectly insulated from the cans; cans are automatically grounded through the mounting clamps; and all condensers are oil-impregnated and oil-filled (not wax-filled) with SPRACOL, the 500° flash protection oil.

Lifeguards are supplied free with every Sprague Transmitting Condenser—or you can buy them for your old condensers at 15¢ per pair, amateur net.

SAVE MONEY! . . . with Type UC Transmitting Condensers

For either beginners or old timers who don't want to invest much money in a rig, we heartily recommend Sprague Type UC cardboard type "uncased" paper sections. They'll do a tip-top job on requirements up to 1,000 volts at about one-third the price of standard high voltage units. You can buy a UC-14 1 mfd. 400 volt condenser for only 45¢ amateur net; a UC-18 1 mfd. 800 volt for only 75¢; or a UC-11 1 mfd. 1,000 volt for only 90¢ net. Other capacities proportionately low. It should pay you to investigate!

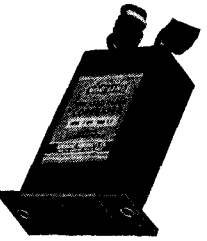

TRY TELEVISION!

Along with a lot of other amateurs, you'll probably soon be giving Television a whirl—and when you do, look to Sprague for the right condensers. For several years past, we have been working with leading equipment manufacturers and have developed a complete line of quality units specifically constructed for exacting Television requirements. See page 20 of the new Sprague Condenser Catalog for standard types now generally available.

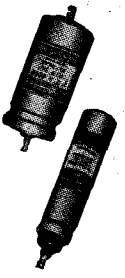

LOOK AT THESE RESISTOR VALUES!

Study the construction of Sprague Koolohm Resistors. See for yourself the tremendous plus-values you get every time you use one. Common sense will tell you the advantage of having every bit of wire insulated before it is wound with a special heat-proof, moisture-resistant material. Layer windings, larger wire sizes, more resistance in less space, 5% accuracy, no chance for shorted windings, cooler operation, inexpensive non-inductive windings . . . these are but a few of the resulting features that are unsurpassed in the resistor market today. Write for Koolohm Catalog.

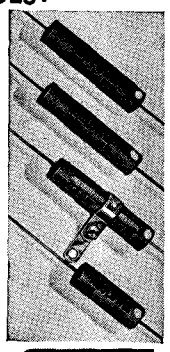

AVOID FAILURES!

Other condenser types come and go, but famous Sprague TC Tubulars go on forever. The reason? Well, it's simply that you can't beat them for any by-passing requirement. Test voltage 1200, working voltage 600. Made in a complete line.



"Not a Failure in a Million"

GET THIS CATALOG FREE!

The biggest most complete Condenser Catalog Sprague has ever issued. Ask your jobber or write to us. Ask for the 1941 Catalog.

SPRAGUE KOOLOHM RESISTORS



Cross Section—showing progressive interleaved windings for higher resistance values in less space.



Cross Section—Showing wire used in Koolohms with a section of the insulation removed.

SPRAGUE PRODUCTS CO.

North Adams, Mass.



is linear, what will the oscillation frequency be at a temperature of 60 degrees Centigrade?
1999.8 kc.

34. A low-drift crystal for the 3500-4000 kc. amateur band is guaranteed by a manufacturer to be calibrated to within 0.04% of its specified frequency. Desiring to operate as close to the lower band limit of 3500 kc. as safely as possible, for what whole-number kilocycle frequency should you order your crystal, allowing 1 kc. additional for variation from temperature and circuit constants?

3503 kc.

35. For what frequency should you order your crystal for operation as close as safely possible to the upper band limit of 4000 kc., with the same calibration accuracy and allowance given in Question 34?

3997 kc.

36. Draw a schematic diagram of a full-wave single-phase power supply using a center-tapped high-voltage secondary with a filter circuit for best regulation, showing a bleeder resistor providing two different output voltages and a method of suppressing "hash" interference from the mercury-

vapor rectifier tubes. Give the names of the component parts and approximate values of filter components suitable for either amateur radiotelephone or radiotelegraph operation.

See diagram A36.

37. Draw a simple schematic diagram of a plate-neutralized final r.f. stage using a triode tube coupled to a Hertzian antenna, showing the antenna system and a Faraday screen to reduce harmonic radiation.

See diagram A37.

38. Draw a simple schematic diagram of a half-wave rectifier with a filter which will furnish pure d.c. at highest voltage output, showing filter condensers of unequal capacitance connected in series with provision for equalizing the d.c. drop across the different condensers.

See diagram A38.

39. Draw a simple schematic diagram of a piezo-electric crystal-controlled oscillator using a pentode vacuum tube, indicating polarity of electrode supply voltages where externally connected.

See diagram A39.

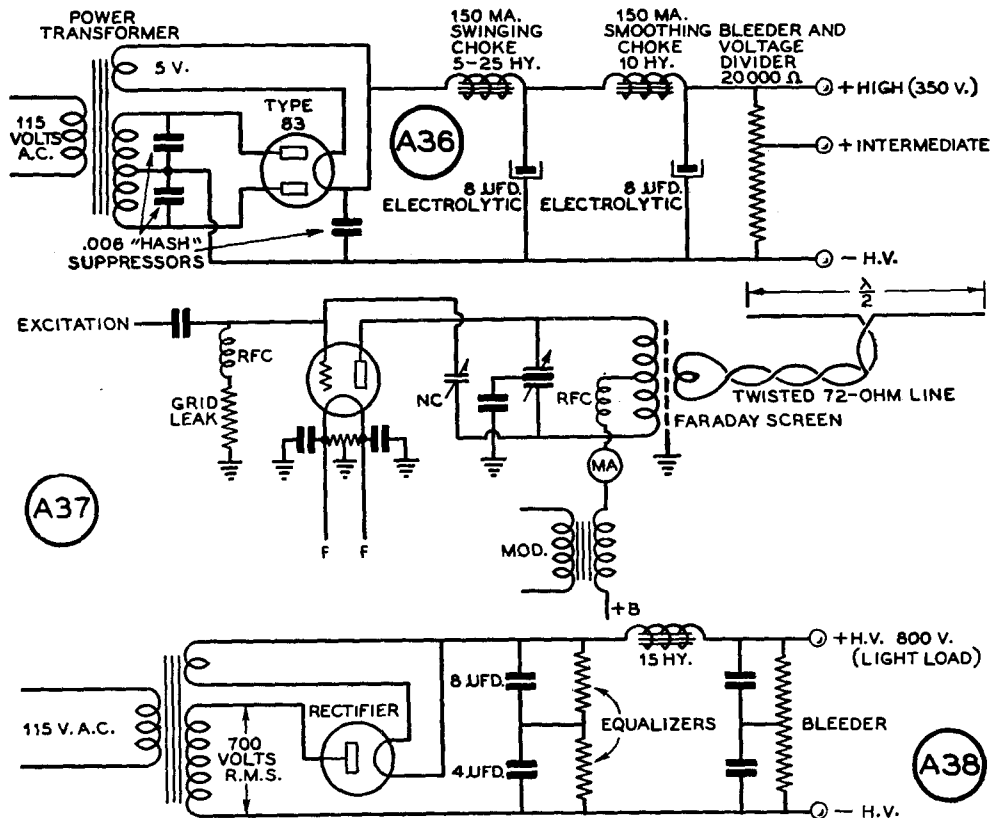

new "HFB" condenser with INSULATED ROTOR

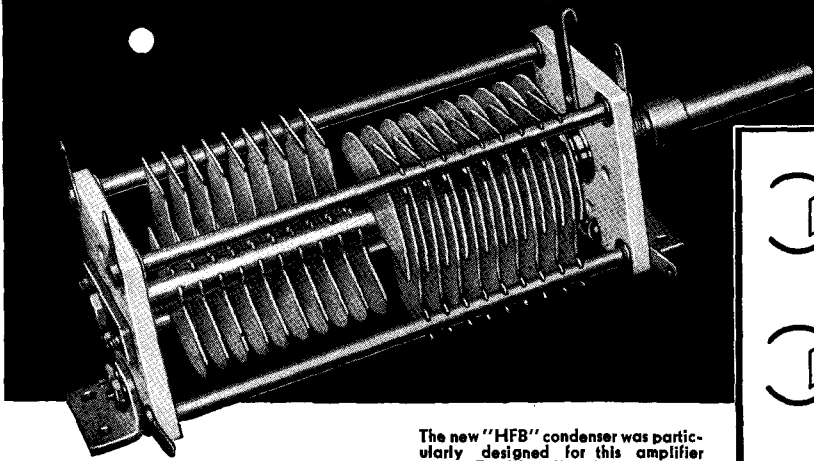

The new "HFB" condenser was particularly designed for this amplifier circuit. The "HFB" in this circuit permits the use of higher plate voltages for a given condenser plate spacing.

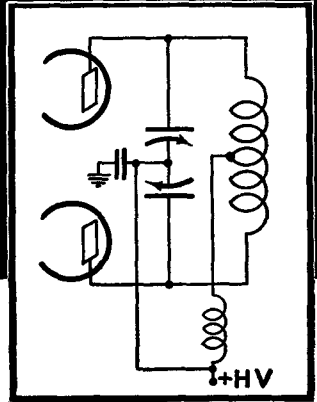

THE new Hammarlund "HFB" transmitting condenser offers the amateur a solution to many difficult problems. In design, the "HFB" is radically different from the usual transmitting condenser. The use of Isolantite end plates and an insulated control shaft permits the use of higher voltages for a given plate spacing, resulting in a more compact condenser with its associated increase in efficiency. Also, a greater measure of safety is offered the operator. The danger of shock is greatly reduced due to its full insulated feature. All superfluous metal framework has been eliminated. Greater high frequency stability and efficiency is thus obtained. Losses are reduced to a minimum through the use of soldered brass plates, cadmium plated. There

exists no staking, riveting, or clamping, to introduce the danger of high resistance contacts. Model illustrated is "HFBD-65-E" and is suitable for use with up to 3,000 V. applied to the tubes. This new condenser is made in all popular sizes. In addition, there is another line of "HFA" type condensers similar in design but smaller in size. They are ideal for low power stages and for portable use. Write for complete details.

MAIL COUPON TODAY!

HAMMARLUND MFG. CO., INC.
424-438 W. 33 St., N. Y. City
Please send latest catalog.

RH-41

Name.....

Address.....

City..... State.....

Canadian Office:
41 West Ave. No., Hamilton



HAMMARLUND

EXPORT DEPARTMENT, 100 VARICK ST., NEW YORK CITY

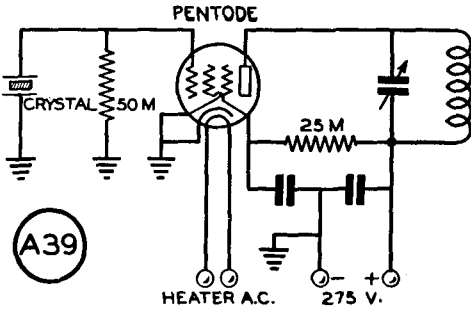

40. Draw a simple schematic diagram of two r.f. amplifier stages using triode tubes, showing the neutralizing circuits, link coupling between stages and between output and antenna system, and a keying connection in the negative high-voltage lead including a key-click filter.

See diagram A40.

41. Draw a schematic diagram of a filter for reducing amateur interference to broadcast reception consisting of a series-tuned circuit connected in shunt with the b.c. receiver input to bypass the interfering signal and a parallel-tuned (trap) circuit in series with the receiver input to reject the interfering signal.

See diagram A41.

42. Draw a schematic diagram of a pentode audio power amplifier stage with an output coupling transformer and load resistor, showing suitable instruments connected in the secondary for measurement of the audio-frequency voltage and current, and naming each component part.

See diagram A42.

43. What is the principal purpose of using door interlock switches on a transmitter?

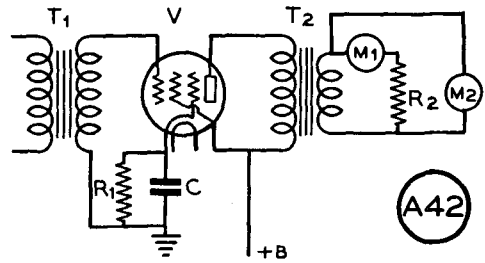
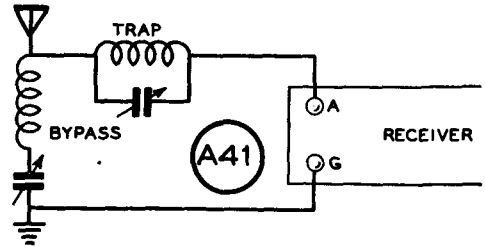

Door interlock switches are used to protect the operator by opening the a.c. line voltage when the door is opened.

44. What is the usual means for protecting amateur station equipment from damage by charges of atmospheric electricity on the antenna system?

By grounding the feeders or a voltage node on the antenna through an r.f. choke or a high resistance non-inductive resistor. When not in use the antenna is grounded directly through a grounding switch.

45. What is a safe procedure for removing an unconscious person from contact with a high voltage circuit?

Turn off the voltage, or if impossible, pull him free by loose folds of clothing (if dry).

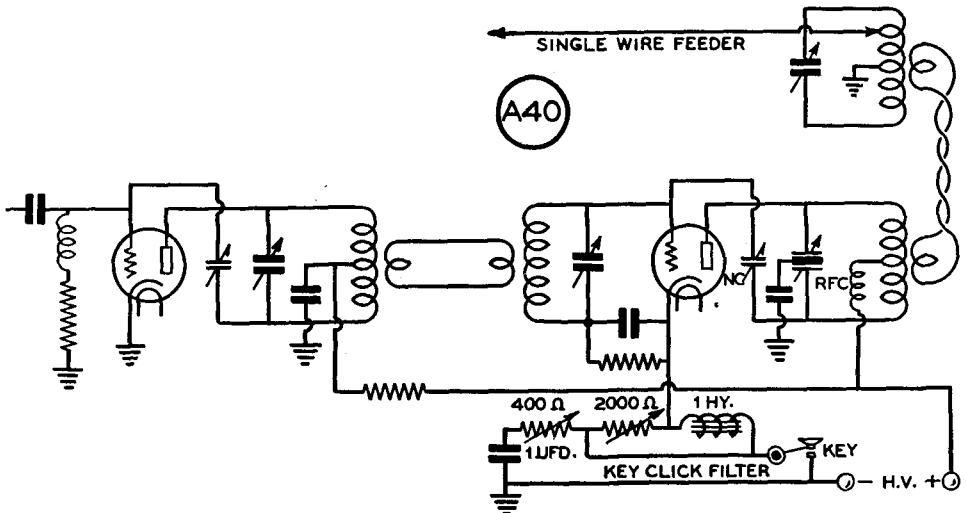

Taylor CUSTOM BUILT Tubes

"More Watts per Dollar"

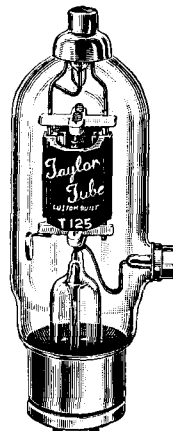
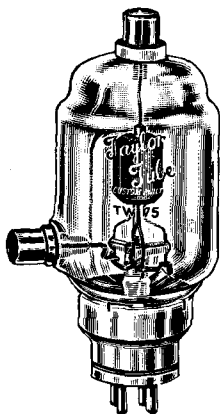
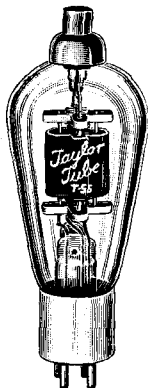

TRIODES

Class C Service

Type	Fil. Volt	Fil. Amp.	Amp. Factor	G-P mmf.	Pl. Volt	Pl. Ma.	Grid Ma	Pl. Diss. Watts	List Price
T-20	7.5	1.75	20	5.0	750	85	25	20	\$ 2.25
TZ-20	7.5	1.75	62	5.0	750	85	30	20	2.25
T-40	7.5	2.5	25	4.8	1500	150	40	40	3.50
TZ-40	7.5	2.5	62	5.0	1500	150	45	40	3.50
T-55	7.5	3.0	20	3.85	1500	165	40	55	6.00
TW-75	7.5	4.15	20	1.5	2000	175	60	75	8.00
T-125	10.0	4.5	25	6.0	2500	250	70	125	13.50
TW-150	(A)	(A)	35	2.0	3000	200	60	150	15.00
T-200	10.0	5.75	17	7.9	2500	350	75	200	21.50
203A	10.0	3.25	25	14.0	1250	175	60	100	10.00
203Z	10.0	3.25	85	—	1250	175	50	65	8.00
204A	11.0	3.85	25	15.0	2500	300	80	250	60.00
211	10.0	3.25	12	14.0	1250	175	60	100	10.00
211C	10.0	3.25	12	9.0	1250	175	60	100	12.50
HD203A	10.0	4.0	25	14.0	1750	250	60	150	14.50
HD211C	10.0	4.0	12	8.0	1750	250	60	150	14.50
303C	10.0	3.25	25	8.0	1500	175	60	125	14.50
805	10.0	3.25	45	7.7	1750	200	70	125	13.50
814	10.0	4.0	12	13.5	2500	300	70	200	18.50
822	10.0	4.0	30	13.5	2500	300	70	200	18.50
845	10.0	3.25	5	14.0	1250	150	60	100	10.00

(A) Available in large or small base with 10v.-4.1a. or 5v.-8.2a. fil

BEAM POWER TUBE

T-21	6.3	0.9	138	1.4	400	95	5	21	1.95
------	-----	-----	-----	-----	-----	----	---	----	------

TRIODES

Class B Audio Service

Type	Drive Power Watts	Output Watts	Pl. Volt	Pl. Ma.	Load Ohms
TZ-20	2.6	80	750	170	9000
TZ-40	6.0	250	1500	250	12000
203Z	6.75	300	1250	350	8000
805	10.0	510	1750	420	9350
822	8.0	1000	3000	450	16000

All Class B Ratings are for Two Tubes

RECTIFIERS

Half-Wave Mercury Vapor Tubes

Type	Fil. Volt	Fil. Amp.	Peak Inv. Volt	A. V. Pl. MA.	Peak Pl. Amp.	List Price
866	2.5	5.0	10,000	250	1.0	\$ 1.50
866 Jr.	2.5	2.5	5,000	125	0.5	1.00
249 B	2.5	7.5	10,000	375	1.5	5.00
258 B	2.5	7.5	10,000	375	1.5	6.00
872 A	5.0	6.75	10,000	1250	5.0	10.50
875 A	5.0	10.0	15,000	1500	6.0	30.00

SOLD THRUOUT THE WORLD
BY THE LEADING DISTRIBUTORS

Secure your copy of the famous Taylor Tubes Manual free of charge at your Distributor or send \$.05 direct to Factory. Complete data and curves on all Taylor Tubes and the latest Transmitter Circuits.

TAYLOR TUBES, INC. 2341 Wabansia, Chicago, Ill.

46. Using a frequency meter with a possible error of 0.75%, on what whole-number kilocycle frequency nearest the high-frequency end of the 3500-4000 kc. amateur band could a transmitter safely be set?

3970 kc.

47. Using a frequency meter with a possible error of 0.75%, on what whole-number kilocycle frequency nearest the low-frequency end of the 7000-7300 kc. amateur band could a transmitter safely be set?

7053 kc.

48. What radio messages have priority over all other communications?

Distress messages and communications relating thereto.

49. What is the penalty for willful or malicious interference with other radio communications?

Suspension of the license of the operator in the case of willful interference to ordinary communication; up to \$10,000 and 2 years in prison in case of a distress message.

50. What is the F.C.C. rule regarding emission of unmodulated carriers by amateur stations?

Except for brief tests or adjustments, an amateur radiotelephone station shall not emit a carrier wave except for the purpose of communication.

51*. On what amateur bands is portable operation permissible without prior notification to the inspector of the district in which such operation is contemplated?

On the amateur bands above 56,000 kilocycles.

52*. When may third-party messages be handled between amateur stations of different countries?

Amateur communication between the United States and foreign countries is not permitted.**

53. What period of each hour shall be used for making important initial calls when a state of communication emergency has been proclaimed by the F.C.C.?

The first five minutes of each hour.

54. When does a state of emergency affecting amateur communications become effective and when is it terminated?

The Commission shall declare that a state of general emergency exists, and the state of emergency shall be in effect until the Commission shall have declared such emergency to be terminated.

* IMPORTANT NOTE: Answers to questions 51, 52 and 60 are as of the time of writing, and are in compliance with emergency regulations. (See page 540).

** It should be borne in mind that United States possessions are not considered foreign, and contact with them is permitted.

55. What amateur bands are affected and what frequencies are reserved for emergency calling when a state of communications emergency has been proclaimed by the F.C.C.?

The 1715-2000 kc. and the 3500-4000 kc. amateur bands are affected. The frequencies 1975-2000, 3500-3525, and 3975-4000 shall be reserved for emergency calling channels.

56. On what frequencies may a licensee holding Class-B amateur privileges operate an amateur radiotelephone station.

1800-2000 kc. and on all amateur frequencies above 28,500 kc.

57. What is the F.C.C. regulation regarding transmission of music by an amateur radiotelephone station for testing purposes?

It is unlawful regardless of purpose.

58. What is the highest modulation percentage of an amateur radiotelephone transmitter permitted by F.C.C. regulations and under what condition may it be employed?

100 per cent when the transmitter is capable of 100 per cent modulation without distortion.

59. What power input should an amateur station use for a particular communication which the maximum legal input is 1 kw?

The minimum power which will permit satisfactory communication with the desired station.

60.* On what amateur bands is portable operation permitted only when prior notification has been given to the F.C.C. inspector in charge of the district in which such operation is contemplated?

Domestic testing and developing of self-powered portable and portable-mobile equipment intended for use in domestic communication emergencies, during the hours between sunrise and sunset, local time, on Saturdays and Sundays of each week, is permitted in frequencies below 30,000 kc. provided notice of such testing and development operation shall have been given at least 48 hours in advance to the F.C.C. inspector in charge of the district in which operation in a fixed location will not exceed four months; in this case portable operation is permitted provided the inspector in charge of the district in which operation is contemplated is notified in advance.

61. On what amateur bands is adequately filtered d.c. plate power supply *not* required for operation of an amateur transmitter?

On all amateur frequencies above 112,000 kc.

63. What is the maximum permissible plate power input to the final stage of an amateur transmitter and under what circumstances may it be used?

The maximum permissible plate power input to the final stage is 1000 watts, provided a means is available for measuring accu-

KENYON

QUALITY TRANSFORMERS

Behind the doors of some of America's finest radio transmitting equipment, Kenyon Transformers carry on —doing their work quietly, efficiently, dependably even under the most adverse conditions. Such a record of performance is truly a model for the entire industry.

KENYON PORTABLE BROADCAST UNITS

These excellent units are small yet extremely efficient. For both field and station operation.

LABORATORY STANDARD UNITS

"The Standard of the World." Used by the most discriminating for faithful reproduction.

MODULATION TRANSFORMERS

We manufacture all types up to and including the 10 K.W. units for commercial service.

SPECIAL UNITS

A large portion of the business done by Kenyon is on special units to fulfill special applications. Small or large quantities.

AUDIO TRANSFORMERS

- Shielded, Humbucking types.
- Lab. Standard units, uniform from 20 to 20,000 cycles.
- Plug in types for governmental, aircraft and other applications where space is at a premium.

FILAMENT TRANSFORMERS

Every conceivable type from the smallest to the great high reactance type for 50 KW final.

PLATE TRANSFORMERS

From the 75 volt bias type to the huge 3 phase air and oil cooled units for large plants, broadcast stations, etc.

AMATEUR TRANSFORMERS

Long a favorite with amateurs everywhere. On this page we list but a few of the many types we manufacture. Complete catalog FREE on request.

UNIVERSAL MODULATION TRANSFORMERS

Type No.	Audio Output	Net Price
T-489	Primary	\$2.70
T-493	15 watts	3.90
T-494	40 watts	5.85
T-495	75 watts	13.20
T-496	125 watts	19.80
T-496	300 watts	

PLATE TRANSFORMERS

Type No.	D.C. Volts	D.C.M.A.	Net Price
T-668	500/750	300	\$5.85
T-669	1000/1250	300	9.60
T-670	1500/1750/2000	300	12.90
T-671	1000/1250	500	12.90
T-672	1000/1250/1500	300	11.85

FILAMENT TRANSFORMERS

Type No.			Net Price
T-388	2.5, 5, 6.3 V-3A	1000 V. Test	\$1.65
T-352	2.5 V.-10 A. CT.	2000 V. Test	2.10
T-360	2.5 V.-10 A. CT.	5000 V. Test	3.00
T-389	2.5 V.-10 A. CT.	9000 V. Test	4.50
T-390	5 V.-20 A. CT.	10000 V. Test	8.40
T-391	5 V.-20 A. CT.	5000 V. Test	4.80
T-387	6.3, 6.45, 6.6 V.-8A	2000 V. Test	2.40

FILTER REACTORS

Type No.	Inductance Henries	Max. M. A.	Net Price
T-152	10	200	\$1.95
T-153	30	90	2.40
T-166	11	300	4.65

SWINGING REACTORS

Type No.	Inductance Henries	Max. M. A.	Net Price
T-506	5-20	200-30	\$1.95
T-510	6-19	300-30	2.40
T-517	15-45	90-20	4.65

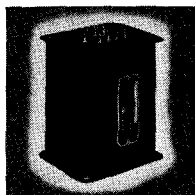

The one style, universal mounting case design of Kenyon Transformers adds eye appeal and beauty to the finished product.

Send for FREE CATALOG Showing hundreds of types not listed above.



KENYON TRANSFORMER CO., Inc.

840 BARRY STREET

NEW YORK, N. Y.

OFFICES IN PRINCIPAL CITIES

Cleveland 3292 Cedarbrook Rd. Seattle 2605 Second Ave. New Orleans 610 Girod St.
 Chicago 21 E. Van Buren St. Los Angeles 2412 7th St. W. Lutz Florida
 Kansas City, Mo. 2004 Grand Ave. Dallas P. O. Box 4116, Sta. A Richmond, Va. 3106 Edgewood Ave.

rately the power input to the stage, and provided that this amount of power input is necessary for communication with the desired station.

64. How would a short circuited turn of the coil affect the resonance frequency of a tuned circuit and why?

A shorted turn in the coil of a tuned circuit would raise the frequency of resonance since the inductance of the coil would be lowered.

65. What is meant by the harmonic of a fundamental frequency?

The harmonic of a frequency is an exact integral multiple of the fundamental frequency (2 times, 3 times, etc.)

66. What operating characteristics distinguish the electron-coupled type oscillator with regard to frequency stability?

The electron-coupled oscillator when properly designed has improved stability of frequency with respect to changes in supply voltages.

67. What circuit conditions will minimize the harmonic components in the output circuit of a given radio-frequency amplifier stage?

Operation of the stage as a push-pull amplifier, operation of the tubes into a circuit of high Q or C/L ratio, avoidance of unnecessarily large values of excitation and control grid bias.

68. Give the meanings of the following "Q" signals: QRK QRM QRT QRX QSA QSY QSZ.

QRK—The legibility of your signals is (1 to 5).

QRM—I am being interfered with.

QRT—Stop transmission.

QRX—Wait. I shall call you again at . . . (or immediately).

QSA—The strength of your signals is (1 to 5).

QSY—Shift to transmission on . . . kilocycles.

QSZ—Transmit each word or group twice.

CLASS A STUDY GUIDE

1. In diagram Q1-A: (a) What is the d.c. plate voltage? (b) What is the d.c. grid bias? (c) What is the supply voltage?

The d.c. plate voltage is 75 volts, the d.c. grid bias 7.5 volts, and the supply voltage 82.5 volts.

2. What undesirable effects may result from a self-oscillating buffer amplifier in a transmitter?

The frequency of the transmitted signal may be determined by the self-oscillating buffer, which might be oscillating outside the band. In other cases, the oscillating buffer may beat with the regular oscillator to produce several spurious frequencies in the output of the transmitter.

3. What type amplifier and class of operation is usually preferred for a frequency doubler?

A push-push type class C amplifier, using high bias and either pentode or beam tetrode tubes makes the best frequency doubler.

4. Why is it advisable to use a separate plate power supply for the oscillator of a multi-stage transmitter?

This form of isolation provides the best possible decoupling, and protects the oscil-

lator from plate voltage changes at an a.f. rate as a result of modulation of a succeeding amplifier stage.

5. What is the most useful operating characteristic of a "push-push" type of amplifier?

A push-push amplifier makes an excellent frequency doubler because it is self-neutralized; no fundamental frequency output can appear in the plate tank, and there is no flattening of the excitation waveform as a result of degeneration.

6. What are the operating characteristics of the electron-coupled type oscillator with regard to frequency stability?

If the screen of the oscillator is supplied from a voltage divider on the plate supply and carefully adjusted to the correct value of screen voltage (as determined by experiment), then supply voltage fluctuations have negligible effect upon the frequency of oscillation.

7. What circuit conditions will minimize the harmonic components in the output of an r.f. power amplifier?

The amplifier should be of the push pull type, have sufficient tank circuit "Q" when loaded, and use no more bias and excitation than is required for the class of operation desired. A split-stator tank condenser with the rotor of the condenser grounded will minimize harmonic content in a tank circuit.

8. What is the principal disadvantage of using a grid leak as the only source of bias in a class C radio frequency power amplifier?

Unless the amplifier tube(s) has a very high amplification factor, the tube may be damaged by excessive plate dissipation should the excitation voltage fail.

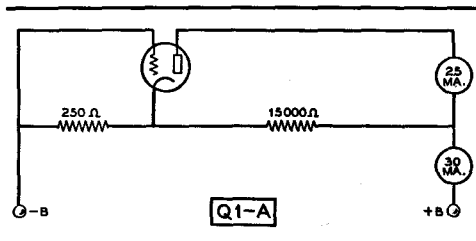

It's RME Every Time!

TAKE A LOOK AT THE NEW RME-99

Regardless whether your radio communications requirements lie in the commercial field for industrial application, or whether you have an amateur's interest in the ultra-highs or in message handling on 40 meters no matter what your requirements, **there is** an RME receiver or accessory unit designed exactly to meet your specifications.

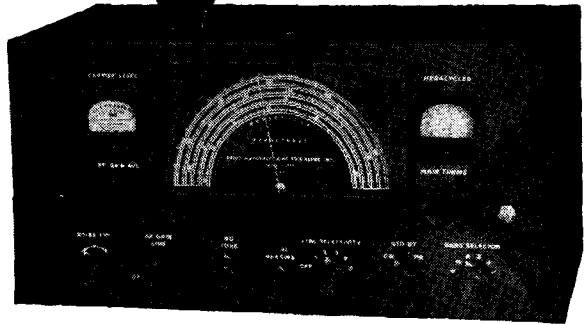

then

FOR STANDARD
COMMUNICATIONS
RECEPTION



FOR ULTRA-HIGH RECEPTION



FOR SPECIAL SERVICE
RECEPTION



RUN YOUR EYE DOWN THIS LIST OF FINELY CONSTRUCTED, PRECISION BUILT RECEIVING EQUIPMENT AND CHOOSE THE UNIT TO FIT YOUR NEED. The new RME-99 standard communications model pictured, is a fine example of the outstanding craftsmanship which will be found in all RME instruments. When you buy RME, you may rest assured that you have the finest equipment that money can buy!

Announced only a short time ago, the RME-99, 12 tube receiver, offers the professional and amateur operator the finest in communications reception. Here is a receiver, in which its custom-built, precision design, enables it to be changed, easily and readily to conform to individual specifications for commercial or amateur use. What are your requirements?

RME has long been acknowledged "tops" in the ultra-high frequency field. The DM-36 BAND EXPANDER and DM-30X units convert your present standard receiver to accurate and efficient reception of frequencies up to 60 megacycles; the HF series of COMPLETE RECEIVERS provide ultra-high frequency reception of a type comparable to ordinary receivers operating at frequencies of 6 megacycles or less. Scientific design, plus, thorough laboratory investigation is the reason for RME's superiority in this field.

Portable receivers, aircraft receivers, commercial crystal controlled tuners, preselectors, oscilloscope amplifiers, industrial communications apparatus, and almost anything you can think of in this field, will be found included in RME's long list of fine communications instruments.

WHY NOT WRITE US TODAY? STATE YOUR REQUIREMENTS, AND LET US SOLVE YOUR RECEIVING PROBLEMS FOR NOW AND ALL TIME. THE RADIO MANUFACTURING ENGINEERS HAVE BEEN DESIGN SPECIALISTS IN THE ELECTRONIC FIELD FOR ALMOST A DECADE!

RME
TIME WILL TELL
RME

RADIO MFG. ENGINEERS

INCORPORATED

111 HARRISON STREET

PEORIA

ILLINOIS

9. What are the relative merits of triodes and screen grid tubes as r.f. amplifiers?

Triodes are less expensive for a given power output, and generally permit slightly higher efficiency. However, they require neutralization except when used as frequency multipliers, and require appreciable excitation power when used as a class C amplifier or frequency doubler.

Screen grid tubes are more expensive, do not permit quite as high a maximum efficiency, and require special consideration when plate modulated. However, they do not require neutralization if designed for such use, and will permit good output and efficiency either as a straight amplifier or frequency multiplier with a comparatively low value of excitation power.

10. Show by a diagram the sinusoidal modulation envelope of an amplitude-modulated wave:

- (a). Modulated approximately 75 per cent.
- (b). Modulated approximately 100 per cent.
- (c). Modulated substantially more than 100 per cent.

Refer to diagram Q10-A.

11. Draw a diagram of a plate-neutralized triode r.f. amplifier stage.

Refer to diagram A11-A.

12. Draw a diagram of a coupling system between two audio frequency stages, employing resistance elements.

Refer to diagram A12-A.

13. What are the principal reasons for using a choke-input type filter in a power supply using mercury vapor rectifier tubes?

To minimize the peak current through the rectifier tubes (for a given load current). Also, a choke input filter will provide better regulation.

14. Would mercury vapor or high vacuum type rectifier tubes of equivalent ratings be preferable for a power supply in which filament and plate voltages must be applied

simultaneously? Give the reason for your choice.

Except when run at greatly reduced ratings, mercury vapor rectifiers will be permanently damaged if plate voltage is applied before the cathode has reached full operating temperature. Therefore, high vacuum type rectifiers would be preferable in this case.

15. What visible operating characteristic distinguishes mercury vapor rectifiers?

Mercury vapor rectifiers exhibit a characteristic bluish glow when operating normally under load.

16. Why are mercury vapor type rectifier tubes more critical as to observance of anode voltage rating than high vacuum type rectifiers?

Mercury vapor type rectifiers are subject to arc back and permanent damage when the inverse peak voltage exceeds a certain critical value.

17. What advantage has a push pull audio frequency amplifier over a single-tube class A amplifier of similar excitation requirement and equal power output?

A push pull amplifier has a lower value of even harmonic distortion. Also, the plate supply for the push pull stage need not be so well filtered.

18. What are the distinguishing operating characteristics of a class A type amplifier?

A class A amplifier is operated over the linear portion of the characteristic curve. The peak output and peak efficiency are both rather low. The average plate current remains constant. Usually the grid is operated entirely in the negative region, though sometimes in special circuits the grid is driven positive.

19. What improper operating conditions are indicated by upward or downward fluctuation of the plate current in a class A amplifier when signal voltage is applied to the grid? What correction should be made?

Assuming that the waveform of the exciting voltage is symmetrical, an upward shift in plate current indicates excessive negative grid bias and a downward shift in plate current indicates insufficient negative grid bias. The bias should be adjusted until the plate current does not fluctuate even when excessive audio input is applied to the grid, unless the plate dissipation is exceeded. In the latter case, the bias should be adjusted until

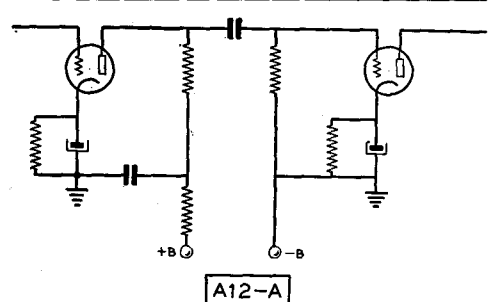
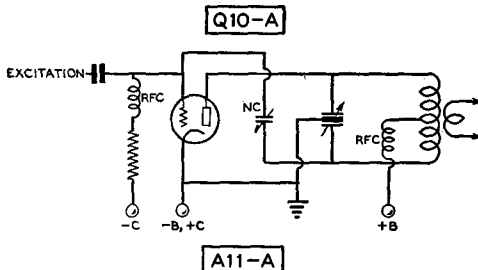
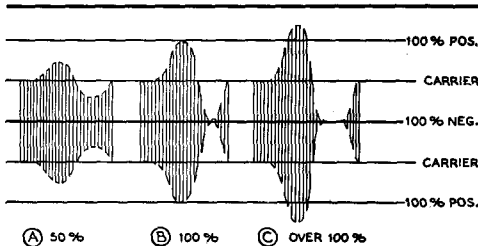

Centralab

The Quality Line

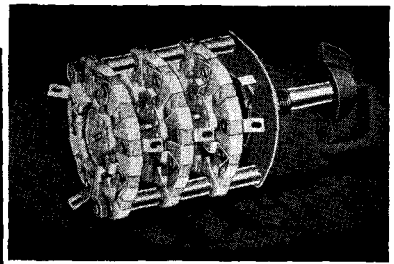

SELECTOR SWITCH

Available in an almost infinite variety of combinations . . . in bakelite or isolantite . . . in single or multiple gang . . . from two to eleven positions on any one switch . . . also available for use in amateur transmitters.

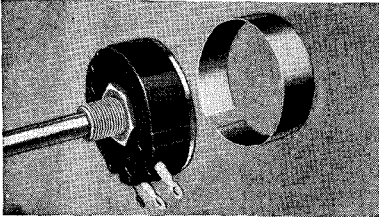

STANDARD RADIOHM

Featuring maximum resistor length to case diameter . . . accurate tapers . . . low noise level . . . longer life . . . better power dissipation and better all 'round performance.

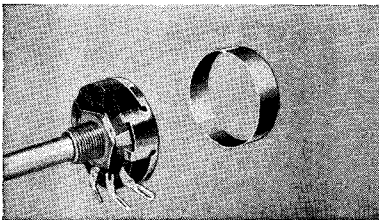

MIDGET RADIOHM

In compact sets space is at a premium; the MIDGET fills the bill . . . bakelite case 1 1/8" diameter . . . 1/4" aluminum shaft . . . 3 3/8" long milled for standard push-on or set-screw knob.

ATTACHABLE SWITCH COVERS

For standard and wire wound resistors (Radiohms) as well as Midget Radiohms . . . S.P.S.T. . . . S.P.D.T. . . . D.P.S.T. . . . four point . . . S.P.D.T. (operates at clockwise position) and S.P.S.T. with Dummy Lug.



Hams, Servicemen, Experimenters and Manufacturers appreciate the utter dependability of Centralab products. Since 1922 more than a hundred million radio parts bespeak the universal acceptance accorded Centralab products. Send for catalog if your jobber cannot supply you.

CENTRALAB
Div. of Globe-Union Inc.
MILWAUKEE

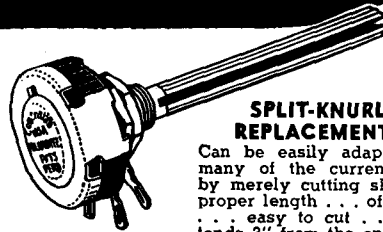

SPLIT-KNURL REPLACEMENTS

Can be easily adapted to many of the current sets by merely cutting shaft to proper length . . . of brass . . . easy to cut . . . extends 3" from the end of a 3/8" bushing.

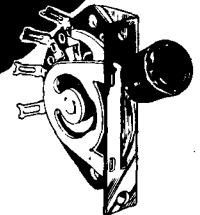

LEVER ACTION SWITCH

Used singly or in groups . . . for broadcasting, receiving, public address, test instruments and industrial uses. Available in any one of ten different combinations including positive and spring return action.

WIRE WOUND RADIOHMS

In values from 2 to 10,000 ohms . . . insulated construction . . . 3 watts . . . universal shaft for all replacements . . . regular Radiohm switch covers may be attached . . . in linear curve only . . .

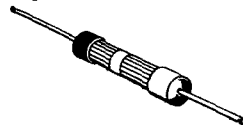

AXIAL LEAD RESISTORS

Body is insulated by inert ceramic jacket . . . proof against vibration and humidity . . . will withstand five times rated load without permanent change. In two sizes . . . RMA coded . . . 1/2 watt at 1/8" x 5/8" and 1 watt at 1/4" x 1".

ADASHAFT MIDGET RADIOHM

Will handle more than 400 different makes (several thousand different models) as far as values and tapers are concerned. A valuable and ideal emergency kit.

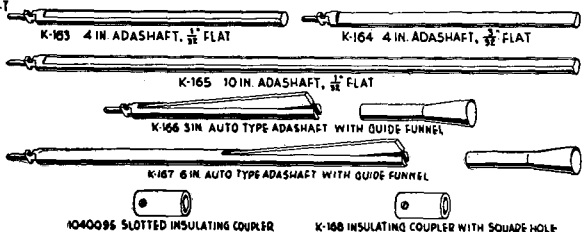
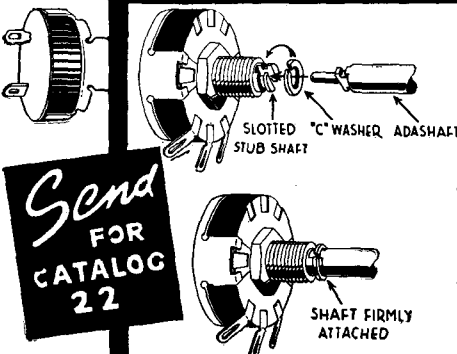

Send
FOR
CATALOG
22

YOU CAN BECOME A MONEY-MAKING RADIO EXPERT with the NEW SPRAYBERRY

Personalized Home Training IN

RADIO and TELEVISION



You Learn Easily in Your Spare Hours. . . By Doing Many Experiments with Up-to-Date Equipment

No matter if you desire to BE YOUR OWN BOSS in your own business, or hold down a good job in Radio, my Personalized Training will quickly give you the useful knowledge to win success. I make it EASY for you to get started.

I Supply



Training Prepares You for Good Radio Jobs . . . at Excellent Pay

My training starts right at the beginning of Radio . . . unfolds each subject in a simplified, logical, understandable style. You easily learn Television, Electronics, Facsimile Radio, Radio set Repair and Installation Work, etc.

No Previous Experience Needed

It makes no difference what your education has been. I can fit you for a good-paying Radio Job. Your success is my full responsibility.

You Get Professional Test Equipment Plus Experimental Outfits

. . . Includes 146 Radio Parts (to build complete receiver), Tools, All-Wave, All-Purpose Analyzer, and Experimental Outfits for conducting actual experiments with your own hands.

Earn While You Learn

My **BUSINESS BUILDERS** show you how to put your Equipment to practical use in handling actual money-making Radio Service Jobs shortly, after you begin training.



The Sprayberry Course Is Sold Under a Money-back Agreement

Read What This Student Says Earned \$250, Since Starting Course

"I have only completed one third of the Sprayberry Course and I find it very interesting, which makes it easy to learn. By devoting several hours' spare time daily to studying and servicing I have made about \$250 gross since starting the course." Earl W. Hostetter, R. No. 4, Lebanon, Pa.

SERVICEMEN

I offer Advanced Training for those already in Radio. Get complete details in my FREE 52-page Book.

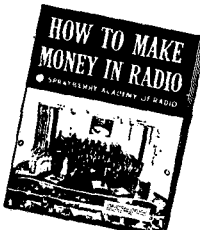

RUSH THIS COUPON for BIG FREE BOOK

SPRAYBERRY ACADEMY OF RADIO
F. L. Sprayberry, Pres.
1610-K University Place, N. W., Washington, D. C.
Please send me FREE copy of "HOW TO MAKE MONEY IN RADIO."

Name _____ Age _____

Address _____

City _____ State _____

Tear off this coupon, mail in envelope or paste on penny post-card.
Servicemen—Check here

the plate dissipation corresponds to the maximum rated value.

20. Why is bias voltage generally necessary on the grid of an audio amplifier tube, and what is the principal result of improper bias?

Negative bias ordinarily is required in order to permit the tube to operate over the desired portion of its characteristic curve. Improper bias reduces the maximum amount of output that is obtainable without objectionable distortion.

21. What improper operating conditions are indicated by grid current flow in a conventional class A amplifier?

Grid current flow indicates either insufficient bias, excessive audio input, or a combination of both.

22. What is the principal advantage of a class B audio amplifier as compared to other types?

For a given pair of tubes, the most possible audio power output (with tolerable distortion) is obtainable with the tubes operating in class B. Thus a high order of output may be obtained with small tubes operating at moderate plate voltage.

23. How should the average plate current vary in a properly designed and operated amplitude-modulated radio-frequency power amplifier?

Assuming a constant carrier system, the average plate current should remain constant during modulation.

24. What are the notable efficiency and distortion characteristics of a class B modulator employing two triodes in push-pull?

A large amount of audio power may be obtained with tolerable distortion, and high average efficiency is obtained.

25. How do the excitation requirements of a class B modulator compare with those of a class A modulator having equal grid voltage swing?

As the grids of the class B modulator tubes are driven considerably positive on modulation peaks, an appreciable amount of driving power is required. Because of the non-linear impedance offered by the grids, the driver stage must be capable of supplying the required power with good regulation.

As the grid or grids of the class A modulator are not driven positive, little power is required to drive the modulator to full output.

26. What would happen if the grid bias supply to a class B modulator were suddenly short circuited?

The bias pack or battery would be damaged if left shorted for more than a very short time. The effect upon the modulator tubes would depend upon their amplification factor and plate resistance. Unless the tubes had a very high amplification factor or the plate voltage were low, the plate dissipation of the tubes would probably be exceeded as a result of the loss in bias.

27. What is the ratio of modulator audio power output to class C amplifier unmodulated plate power input in a plate modulation system:

- (a). With a sinusoidal signal?
- (b). With a two-tone signal equivalent to speech?

Vibrapack . . . The Ideal Source of Plate Voltage for Transmitters, Receivers, P. A. Systems

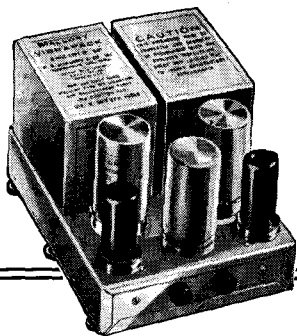

Mallory Vibrapacks have won top honors with radio operators, engineers and public address men everywhere as the most economical source of plate voltage for battery operated equipment. The Vibrapack line includes types for 6, 12 and 32 volt operation, with outputs up to 60 watts in the new dual units. Send for free booklet giving complete technical data.

Constructed with an exclusive dielectric that gives longer life and greater dependability . . . Mallory Transmitting Capacitors are a real safeguard for expensive rigs. This Mallory developed dielectric provides high dielectric constant, high voltage breakdown and high, stable insulation resistance, with low power factor under all operating conditions. See your distributor for TX, TR and TZ types.

P. R. MALLORY & CO. INC.
MALLORY

Transmitting
Capacitors



.. for Meter
Switching

Mallory-Yaxley Push
Button Switch
Type 2190

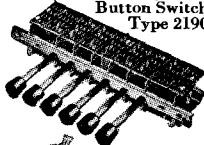

.. for Trans-
mitter Band
Switching

160C Ham-
Band Switch

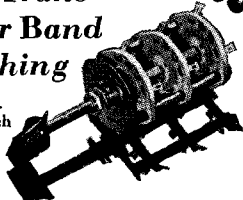

Here are two Mallory-Yaxley switches that give new operating convenience for amateurs. The push button switch makes it possible to measure any one of a number of circuits with a single meter while other circuits connected remain closed. The HamBand Switch brings new convenience to transmitter band switching . . . makes it as easy as receiver band switching. Unique design offers wide range of applications. Write for details.

Other MALLORY Products for Amateurs

Dry Electrolytic Condensers
Wet Electrolytic Condensers
Tip Jacks and Plugs
Phone Plugs
Jacks and Jack Switches
Grid Bias Cells
Vitreous Resistors

Variohm Resistors
Rheostats
Potentiometers
Volume Controls
T & L Pads
Rotary Switches

Cable Connectors
Dial and Panel Lights
Radio Convenience
Outlets
Knobs—Nuts—Washers
Dry Disc Rectifiers
Auto Radio Vibrators

P. R. MALLORY & CO., Inc., Indianapolis, Indiana

Cable Address—PELMALLO

Use
P. R. MALLORY & CO. INC.
MALLORY
APPROVED
PRECISION PRODUCTS

Includes VIBRATORS • VIBRAPACKS • CONDENSERS
VOLUME CONTROLS • ROTARY SWITCHES
SINGLE AND MULTIPLE PUSH BUTTON SWITCHES
RESISTORS • RADIO HARDWARE

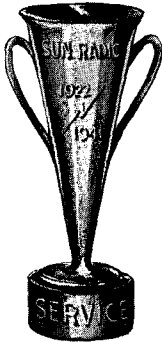

TOPS IN ACHIEVEMENT!

Nobody's showered us with loving cups or pinned any medals upon our heaving chests (as yet) but you ought to see some of the letters pouring in from all corners of the world heaping praise upon praise for our unstinted efforts in providing exemplary SERVICE. No wonder we've a right to crow, for where else but at SUN can you obtain such fine, individual treatment?

Everything in
AMATEUR RADIO
 LARGEST STOCKS in the EAST

ALL NATIONALLY-KNOWN BRANDS
 COMMUNICATIONS RECEIVERS
 TRANSMITTERS
 TUBES — PARTS
 Also PUBLIC ADDRESS SYSTEMS
 F/M — A/M — TELEVISION

TIME PAYMENTS
TRADE-INS ACCEPTED

FREE TECHNICAL SERVICE
 SUN RADIO maintains a highly competent staff of engineers amply qualified to solve the most complex technical problems. Feel free to call upon us whenever you desire any expert advice or suggestions relative to your equipment.

"You'll Find SUN SERVICE is Best"
 W2JEH — W2DXC — W2LFV — W2CLH
 New York's Oldest "Ham" House

SUN RADIO CO.
 212 Fulton St. New York City
 — DEPT. RH —
 Cable Address: "SUNRADIO"

The ratio of 50 per cent with sinusoidal signal and 25 per cent with a signal equivalent to speech.

28. Define amplitude modulation.

Amplitude modulation is the process by which the peak r.f. voltage of the transmitted signal varies in amplitude in accordance with sound to be transmitted. Strictly speaking, the amplitude of the carrier wave does not vary; it is the mixing of the carrier and sidebands which produces the resulting r.f. voltage which varies in accordance with the modulation.

29. What are sideband frequencies?

Sideband frequencies are a product of modulation, and result when the radio frequency carrier wave and audio frequency signal to be transmitted are mixed. They are radio frequency oscillations having a frequency of the carrier frequency plus and minus each modulation frequency. Thus, when a 1000 kc. carrier is amplitude modulated by a 1000 cycle sine wave tone, the transmitted signal will contain the steady carrier at 1000 kc., a sideband at 999 kc., and a sideband at 1001 kc.

30. What radiotelephone transmitter operating deficiencies might be indicated by downward deflection of the antenna r.f. current meter during modulation of the final r.f. amplifier?

If a single ended modulator is used, it might indicate overloading of the modulator. If a class B modulator is used, and fed from the same power supply as the modulated stage, it might indicate poor regulation of the power supply; or, if separate power supplies are used, poor power line regulation. It may also be caused by one flat tube in a class B modulator.

The following deficiencies in a plate modulated class C stage also will cause "downward modulation": inadequate filament emission (flat tube), insufficient bias, insufficient excitation.

When grid bias modulation is used, downward modulation may be a result of insufficient antenna loading, insufficient bias, or excessive excitation.

31. Draw a diagram of a combination heterodyne frequency meter and monitor.

Refer to diagram A31-A. For use as a c.w. monitor or as a heterodyne frequency meter the switch SW is left open so that the circuit will oscillate. For use as a phone monitor it is closed, thus shorting the tickler and preventing oscillation.

32. Draw a simple schematic diagram of a peak modulation monitor which will indicate

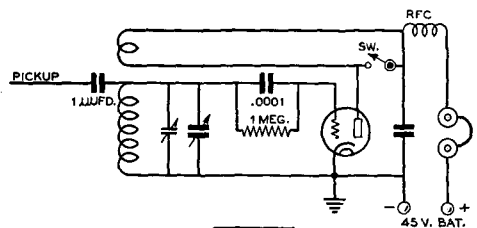

A31-A

Quality above all!

Meissner

PRECISION-BUILT RADIO EQUIPMENT

The Standard of Comparison

UNI-SIGNAL SELECTOR

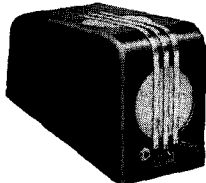

Connects as a speaker to the output of any receiver. Eliminates all interference in the form of QRM, QRN, Tube Hiss, etc. For CW only — can not be used on phone. Has clean, 1000-cycle note. 25-cycle selectivity — takes up where crystal leaves off.

No. 9-1026, Amateur Net.....\$13.75

DE LUXE SIGNAL SHIFTER

The accepted standard for ECO operation. Shifts your frequency to a clear spot with ease and accuracy. All-band operation; voltage-regulated for stability. Features positive oscillator keying for "break-in" operation. Complete with tubes.

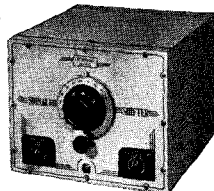

No. 9-1027, Amateur Net.....\$47.50

SIGNAL SPLICER

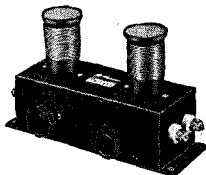

Designed to match any type of antenna to the input of any receiver. Where transmitting antenna is used for receiving also, this unit will provide material increase in Signal Gain. Uses no power — no tubes! Improves image rejection — reduces noise pick-up.

No. 9-1022, Amateur Net.....\$3.95

SIGNAL BOOSTER

Used ahead of any receiver, provides average gain of 40 db. Two stages of high-gain RF amplification, self-powered. Covers full range between 1.8 and 31 mc. Has RF Gain, Range, Antenna Compensator, Cut-Over Switch and Tuning Control. Complete with tubes.

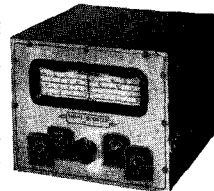

No. 9-1031, Amateur Net.....\$43.50

SIGNAL RESONATOR

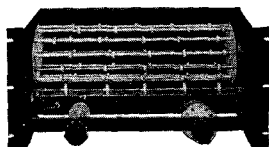

Single Control unit for YOUR transmitter! Automatically sets all condensers, band-switches, etc. to completely tune your transmitter to any of eleven desired frequencies.

Entirely mechanical, easy to install; only 3 seconds to change frequency with the Signal Resonator!

No. 9-1024, Amateur Net.....\$29.50

MC 28-56 CONVERTER

Covers 28 to 30 mc and 56 to 60 mc. Converts to 6.9-7.4 mc IF to work into any communications receiver. Uses 1852, high-gain RF amplifier. Provides consistent reception on the 5 and 10 meter bands. Voltage regulated. Complete with tubes.

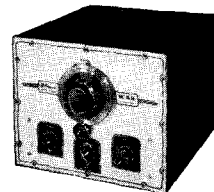

No. 9-1032, Amateur Net.....\$44.75

Write for your Free copy of the New Amateur Catalog
Read the story behind Meissner Precision-Built Equipment

Address Dept. RH-41

Meissner

MT. CARMEL, ILLINOIS

"A FAMOUS NAME FOR TWO DECADES"

**STANDARD B&W AIR
INDUCTORS SOLVE 95% OF ALL
AMATEUR COIL PROBLEMS!**

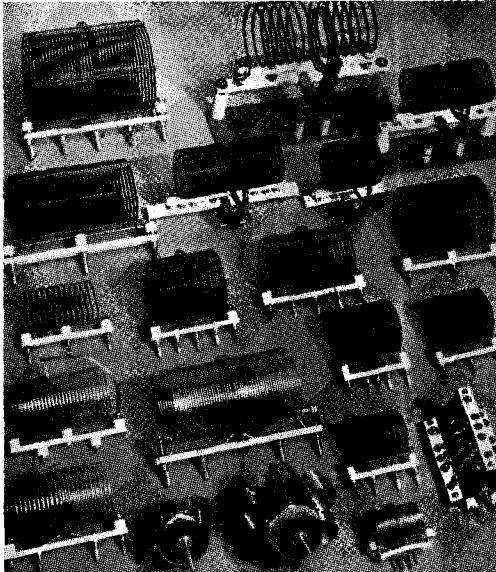

The B&W line is so complete that the selection of the proper inductor for 'most any amateur application is a split-second job. You don't need the help of an engineering genius, nor you don't have to be one, just look in the B&W Catalog—and bingo! . . . you're all set!

You'll find B&W's give you better, more dependable performance. You'll like their unwavering accuracy, their amazing ruggedness, their trim appearance.

The brief listing below gives you an idea . . . but be sure to get the whole story. Ask your jobber to show you the B&W line—or write today for the B&W Catalog.

VARIABLE LINK ASSEMBLIES

- TYPE BVL—100 W. Rating—A compact unit for direct mounting on condenser. Six interchangeable plug-in coils, from 5 to 160 meters.
- TYPE TVL—250 W. Rating—A dependable medium-power assembly. 10 to 160 meter range.
- TYPE TVH—500 W. Rating—New! . . . and "best yet" for those 500 Watt rigs. 10 to 160 meter coils.
- TYPE HDVL—1 K.W. Rating—The rugged heavy-duty favorite for high-power final stages. 10 to 160 meters.

BAND SWITCHING ASSEMBLIES

- 100 W. 5-BAND TURRETS—Type BCL (center linked) and Type BEL (end linked)—Equal in efficiency to the best individual plug-in-coil systems. More compact, faster, lower in cost than any comparative method now available for 100 W. applications. Net, \$8.50.
- B&W "BAND-HOPPERS"—Cover all five bands, yet require very little space. Panel control. Now available in two types—MODEL 2A, (25 W. Rating) for interstage capacity coupling with beam power tubes, \$3.25 net; and MODEL 2AB, (50 W. Rating), for interstage capacity coupling between beam power tubes and triodes or high-powered beam tubes, \$3.50 net.

FIXED LINK INDUCTORS

Four standard and four linked types, each type covering the 10 to 160 meter bands, comprise the B&W Fixed Link line and provide the speedy, correct solution to practically any fixed coil problem. Write for complete listing.

FOR THOSE SPECIAL IDEAS

B&W engineers are at your service—to suggest ways of utilizing standard units, or to design and build special coils and assemblies to meet your requirements. This Service is available through your jobber or direct from factory.

BARKER & WILLIAMSON

Radio Manufacturing Engineers • ARDMORE, PENNSYLVANIA

when 100 per cent modulation occurs or is exceeded.

Refer to diagram A32-A.

33. Draw the trapezoidal type patterns showing 50 per cent modulation, 100 per cent modulation, and overmodulation as they would appear on the screen of a cathode ray oscilloscope properly connected to a phone transmitter.

Refer to diagram A33-A.

34. Draw a diagram of an absorption type frequency meter including a resonance indicator.

Refer to diagram A34-A.

35. Draw a simple schematic diagram of a radio frequency doubler stage driving a neutralized push pull power amplifier using triodes, showing the method of interstage coupling and indicating the relative resonance frequencies of the grid and plate circuits.

Refer to diagram A35-A, page 576.

36. Draw a schematic diagram of a two-stage r.f. amplifier using screen grid tubes, showing a suitable method of interstage coupling.

Refer to diagram A36-A.

37. Using a frequency meter with a possible error of 0.75 per cent, on what whole number kilocycle frequency nearest the low frequency end of the 14,000-14,400 kc. band could a transmitter safely be set?

14,106 kc.

38. Using a frequency meter with a possible error of 0.75 per cent, on what whole number

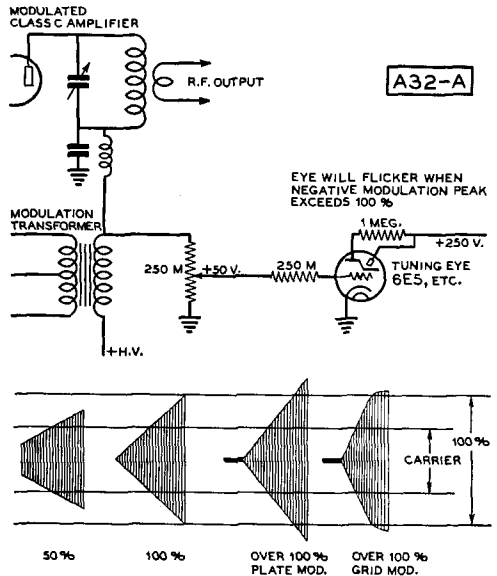

A32-A

A33-A

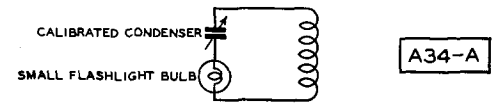

A34-A

THE GIRL WHO WOULDN'T TAKE NOAH

for an answer . . .



This is the story of Noah—a "ham".

Noah was in love with a girl named Doris. Now, as it happened, this Doris was in the market for a good, steady, devoted husband. But she wouldn't take Noah for an answer!

You see, Noah—poor guy—wasted so much of his time — and "hard-earned" — chasing around after this "ham" part and that for his rig that . . . well, it simply knocked all devotion to Doris four ways to Sunday.

Until a ham with a heart tipped Noah off to Lafayette. Like smart amateurs everywhere, Noah now looks to Lafayette for all his radio needs.

It saves time—and how it saves money! Lafayette prices are definitely lower. And Lafayette stocks are always complete. Here is everything—literally everything for the "ham". That includes the hard-to-get stuff now off the market, as well as all the latest nationally advertised amateur radio equipment.

Order at home from our big free catalog. Lafayette's shipping service delivers the goods to your door, quickly and in perfect condition. All of which is why so many hams in-the-know look to Lafayette today for everything in radio.

Are you one of these "hams"?

Answer Yes or Noah.

Our catalog for use in your shack is an up-to-date record of Lafayette's complete stock of quality parts and equipment. Send for your FREE copy of the new 1941 edition.

We know all the answers
— AND HAVE 'EM:

Hammarlund
Hallicrafters
RCA-GE-IRC
National
Lafayette
Bliley
Thordarson
Raytheon
UTC
Cardwell



Aerovox
Sangamo
Weston
Sprague
Belden
Stancor
Vaxley
Meissner
E. F. Johnson

Hytron and others

Lafayette Radio

20th ANNIVERSARY

100 SIXTH AVENUE, NEW YORK,
901 W. JACKSON BLVD., CHICAGO,
265 PEACHTREE STREET, ATLANTA,

110 FEDERAL ST., BOSTON • 24 CENTRAL AVE., NEWARK
542 E. FORDHAM RD., BRONX, N. Y. • 90-09 166th ST., JAMAICA, L. I.

THORDARSON TRANSFORMERS

Below are listed, for your convenience, the Thordarson units required in the construction of the circuits illustrated and described in this Handbook. These are a few of the many Thordarson transformers and chokes available. Complete electrical and physical characteristics of these and many more will be found in Catalog #400-E. A copy will be sent without charge, postpaid, from the factory or will be supplied by your Thordarson Distributor.

815 F. M. Transmitter T-19F99 **\$2.10 Net.**

Frequency Spotter T-13R11 **\$1.65 Net.**

Crystal Calibrator T13R01 **\$1.65 Net.**

Wide Range A. F. Modulator

T-57S01 **\$1.20 Net.** T-13R11 **\$1.65 Net.**

T-13C28 **\$0.72 Net.**

112MC Transmitter T-86A02 **\$1.05 Net.**

T-17M59 **\$1.65 Net.** T-70R62 **\$3.30 Net.**

T-57C53 **\$1.20 Net.**

125-Watt UHF Amplifier T-19F98 **\$1.65 Net.**

Med. Power F. M. Transmitter

T-19F99 **\$2.10 Net.** T-14A90 **\$1.50 Net.**

112MC Receiver T13A35 **\$0.90 Net.**

224MC Receiver T-13A35 **\$0.90 Net.**

Mobile Tranceiver T-72A59 **\$0.99 Net.**

T-13S38 **\$0.90 Net.**

Battery Tranceiver T-72A59 **\$0.99 Net.**

T-14C61 **\$0.60 Net.**

Small C. R. Scope T-92R33 **\$2.40 Net.**

902 Scope with Sweep T-92R33 **\$2.40 Net.**

250-Watt (813) Trans CW

T-19F96 **\$2.10 Net.** T-19F76 **\$2.85 Net.**

T-84P60 **\$3.90 Net.** (2) T-75C51 (Each)

\$3.00 Net.

Receiver Power Supply T-13R13 **\$2.40 Net.**

T-57C53 **\$1.20 Net.**

500-Watt Amplifier T-74F23 **\$3.00 Net.**

700-Watt Amplifier T-19F96 **\$2.10 Net.**

Receiver Power Supply T-13R14 **\$2.55 Net.**

T-68C07 **\$1.20 Net.**

Thordarson transformers are available or will be especially designed and produced for any electronic requirement.

THORDARSON

ELEC. MFG. CO.

500 WEST HURON STREET, CHICAGO

"TRANSFORMER SPECIALISTS SINCE 1895"

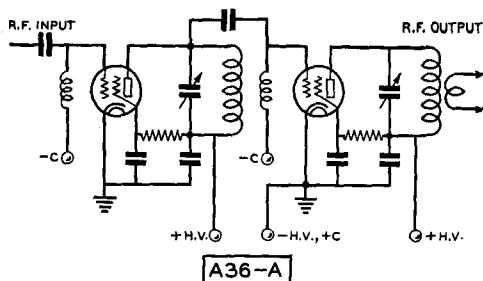

kilocycle frequency nearest the high frequency end of the 14,000-14,400 kc. band could a transmitter safely be set?

14,292 kc.

39. What particular precaution should be observed in using a battery operated heterodyne frequency meter?

Care should be taken that the batteries have not started to run down, as the filament and plate voltages will affect the calibration.

40. What particular precaution should be observed in using an absorption type frequency meter to check a self-excited oscillator?

The inductive coupling should be sufficiently loose that it does not appreciably affect the frequency of oscillation of the self-excited oscillator by altering the effective inductance of the oscillator tank coil.

41. What are the undesirable operation characteristics of a Y-cut crystal and what precautions should be taken when it is to be used for transmitter frequency control?

A Y-cut crystal has a large temperature coefficient of frequency, and therefore the frequency of a Y-cut crystal will change considerably with a change in temperature, especially when the operating frequency is in one of the higher frequency bands.

For a considerable change in temperature, the frequency change with temperature is not continuous; in other words the frequency will suddenly jump when the temperature passes through a certain critical temperature.

Some Y-cut crystals have a tendency to oscillate on either of two closely separated frequencies, depending upon the tuning of the circuit. Under certain conditions the crystal may jump from one frequency to the other, and be unsuitable for frequency control.

42. What is the purpose in using a quartz crystal in a transmitter?

A quartz crystal has an extremely high "Q", and therefore makes an excellent, highly stable frequency determining element.

43. What are the desirable characteristics of an A-cut crystal?

A properly ground A-cut crystal is highly active, will handle considerable power, and has a very low temperature coefficient at room temperatures normally encountered. The frequency change with temperature is not only very low, but continuous.

44. What particular physical characteristic distinguishes an X-cut crystal from Y- and A-cut crystals of the same frequency?

There is a
BURGESS BATTERY
 FOR EVERY PURPOSE

You will find no lazy, inactive cells in Burgess Batteries! First-grade material in carefully selected, tested cells are responsible for Burgess quality. Longer, dependable service, resulting in more econ-

omy, makes Burgess the first choice of amateur, engineer, and scientist. Satisfy yourself on the next dry battery that you need, by specifying Burgess.



No. 4FA Little Six—1½ volts—replaces one round No. 6. Radio "A" type, is recommended for the filament lighting of vacuum tubes. Size, 4¹⁵/₁₆" x 2⁵/₈" x 2⁵/₈". Weight, 1 lb. 6 oz.

No. Z30BP—A new improved midget "B" battery. Adapted for radio, portable receivers and transmitters, laboratory and medical instruments. Taps at minus, plus 22½, plus 45 volts. Size, 2⁹/₃₂" x 3⁵/₈" x 3³/₄". Weight, 1 lb. 7 oz.



No. F2BP—A small 3-volt "A" battery used in portable transceivers, radio test instruments, and portable lighting equipment. Equipped with screw terminals and insulated junior knobs. Size, 1⁵/₁₆" x 2⁵/₈" x 4¹/₁₆". Weight, 12 oz.



No. 2F2H—A 3-volt radio "A" battery used with portable radios, amplifiers, and special instruments. Size, 2⁵/₈" x 2⁵/₈" x 4³/₈". Weight, 1 lb. 6 oz.



No. 44—A special 1½ volt dry cell. Ideal for microphones, laboratory and surgical instruments, and portable radios. Screw terminals and brass knurled nuts. Size, 1⁷/₈" diameter x 4²⁵/₆₄" overall height. Weight, 10 oz.

No. W30BPX—Extremely small and light in weight. Very suitable for personal transceivers used by amateur clubs and radio stations. Equipped with insulated junior knobs. Size, 1¹/₃₂" x 2²⁹/₃₂" x 3³¹/₃₂". Weight, 10 oz.



No. F4BP—A 6-volt heavy-duty portable battery, designed for Burgess X109 headlight. Contains four F cells connected in series. Screw terminals and brass knurled nuts. Size, 2²¹/₃₂" x 2²¹/₃₂" x 4⁷/₃₂". Weight, 1 lb. 10 oz.



No. 2308—Super-service standard size radio "B". Built to deliver maximum service for medium size battery. Designed for receivers with plate current drain of 10 to 15 milliamperes. Size, 7¹/₈" x 8" x 2¹/₈". Weight, 7 lbs. 6 oz.



No. 2FBP—A small 1½ volt "A", designed for radio test instruments, portable amplifiers, and radios requiring 1½ volts for the "A" circuit. Equipped with screw terminals and brass knurled nuts. Size, 1⁵/₁₆" x 2⁵/₈" x 4⁷/₁₆". Weight, 12 oz.

No. 5360—A very compact 4½ volt "C" battery designed for portable use. Brass posts, contacts, and nuts. Size, 3" x 1¹³/₁₆" x 2⁵/₈". Weight, 5 oz.



No. M30—A small light weight "B" battery for use in portable radios. Universal size; will fit the majority of portables on the market today. Size 5⁵/₈" x 3⁹/₁₆" x 1⁷/₈". Weight 1 lb. 10 oz.



The Amateur's Friend

BURGESS

The Engineer's Choice

FOR FURTHER INFORMATION, WRITE BURGESS BATTERY COMPANY, FREEPORT, ILLINOIS

Buyer's Guide

Parts Required for Building Equipment Shown in This Book

The parts listed are some of those actually used by "Radio's" laboratory in constructing the models shown. Other parts of equal merit and equivalent electrical characteristics may usually be substituted without materially affecting the performance of the units.

CHAPTER 6

RAIDO RECEIVER CONSTRUCTION

Figure 4, page 131

Two-Tube Autodyne

C₁—Hammarlund SM-15
C₂—Hammarlund SM-100
C₃, C₅—Solar type MT
C₄, C₆—Solar "Sealdtite"
R₁—Centralab 710
R₂—Centralab "Radiohm"
R₃, R₄—Centralab 514
BC—Mallory 1.25 v.
CH₁—Stancor type C-2300
Panel—Bud PS1201
Tuning dial—Bud D-103B

Figure 7, page 134

Three-Tube Simple Super

C₁, C₂—Hammarlund MC-50-S
C₃—Hammarlund MC-140-S
C₄, C₅, C₁₁, C₁₄—Cornell-Dubilier DT-4P1

"... by the company we keep!"

... so are we known... We are proud to have fourteen CARDWELLS chosen for the model transmitters described in this authoritative amateur transmitter guide. Hundreds of other quality condensers available for all purposes. SEE THEM AT YOUR DEALER

**THE ALLEN D. CARDWELL
MANUFACTURING CORPORATION**
83 PROSPECT STREET, BROOKLYN, NEW YORK

C₅, C₆—Cornell-Dubilier DT-4T1
C₉, C₇, C₁₂—Cornell-Dubilier DT-4S1
C₁₀—Cornell-Dubilier DT-4D1
C₁₃—Cornell-Dubilier BR-252
C₁₅—Cornell-Dubilier EDJ-9040
R₁, R₂, R₄, R₇, R₉—Centralab 516
R₃, R₅—Centralab 514
R₈—Yaxley L
R₉, R₁₀—Ohmite Brown Devil
IFT—Meissner 16-8092
CH—Stancor C-2300
J—Mallory-Yaxley 705
Dial—Crowe 123M

Figure 10, page 137

Economical 5 Tube Super

C₁, C₂—Cardwell ZR-50-AS
C₃—Cardwell ZR-25-AS
C₄—Cardwell ZU-140-AS
C₅, C₇, C₈, C₉, C₁₀, C₁₁, C₁₄, C₁₇—Cornell-Dubilier DT-4P1
C₆, C₁₃—Cornell-Dubilier 5W-5T1
C₁₂—Cornell-Dubilier 5W-5T5
C₁₅—Cornell-Dubilier BR-845
C₁₆—Cornell-Dubilier BR-102-A
R₁, R₆, R₇, R₈, R₁₁, R₁₃, R₁₄—Centralab 710
R₂—Centralab 516
R₃, R₁₀—Centralab 514
R₅, R₉—Mallory-Yaxley G
R₁₂—Ohmite Brown Devil
IFT₁—Meissner 8091
IFT₂—Meissner 8099
Tubes—RCA

Figure 14, page 140

Advanced Bandswitching Receiver

C₁, C₂, C₃—Hammarlund MC-35-S
C₄, C₅, C₆, C₇, C₁₄, C₁₅, C₁₇, C₂₂, C₃₃—Solar MW
C₈, C₉, C₁₁, C₁₂, C₁₆, C₁₈, C₁₉, C₂₀, C₂₁, C₂₃, C₂₄, C₂₆, C₃₀, C₃₅—Solar S-0238
C₁₀, C₁₃—Solar S-0228
C₂₅, C₂₇, C₂₈—Solar S-0219
C₂₉—Solar M-010
C₃₁, C₃₂—Solar DBB-669
C₃₄—Hammarlund SM-15
C₃₆—Meissner 22-7028
C_{1A}, C_{2A}, C_{1B}, C_{2B}—Hammarlund CTS
C_{1C}, C_{2C}—Hammarlund MEX
C_{3A}—Hammarlund APC-100
C_{3B}—Hammarlund APC-75
C_{3C}—Hammarlund APC-50
R₁ to R₃₀ inclusive, R₃₁, R₁₆, R₁₈ to R₂₂ inclusive, R₂₄ to R₃₀ inclusive, R₃₂, R₃₃, R₃₀, R₃₈—Centralab 710
R₁₁, R₁₂—Mallory-Yaxley E
R₁₅—Mallory-Yaxley C1MP
R₁₇—Centralab 516
R₂₃—Mallory-Yaxley E12
R₃₁—Mallory-Yaxley N
R₃₇—Mallory-Yaxley Y10MP
T₁—Meissner 16-8091
T₂, T₃, T₄—Meissner 16-8095
T₇—Meissner 16-5728
T₈—Meissner 16-5730
T₉—Meissner 17-6747
Shield cans for T₅, T₆—Meissner 25-8272

STANCOR Kits-

These are but a few of the many popular kits which appeared in the Fourth Edition Hamanual. All have been revised to incorporate new features found in a year's advancement of the art. Although the prices are extremely attractive, no compromise of design or quality has been tolerated.

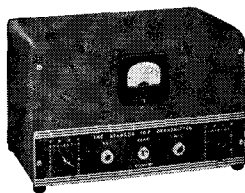

10-P TRANSMITTER

A compact 12-watt phone, 20-watt CW Transmitter for five band operation. Novel design involves but one tuned circuit. Price and features extremely attractive.

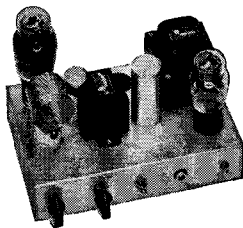

25-B TRANSMITTER

Beginner's 25-watt crystal oscillator for CW. Internal antenna tuning. Flexibility permits experimentation. Very low price.

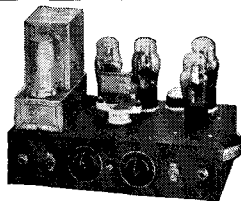

12-E TRANSMITTER

Phone-CW emergency Transmitter. Works from a 6 volt storage battery. Features self-contained universal antenna coupling. No battery drain during standby. Easy band shifting.

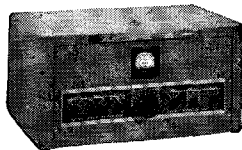

100-MB TRANSMITTER

A real 100-watt Transmitter with front panel band switching, priced remarkably low. Also crystal and meter switching. Easily constructed. Works all bands from 1.7 to 14.4 MC.

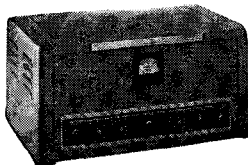

440-M MODULATOR

Companion unit to the 100-MB for radiotelephony. Many other applications. 40 watts of high fidelity audio.

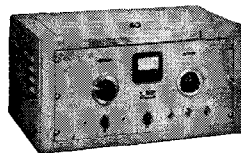

20-N, 60-P, 110-CM TRANSMITTERS

Representative of all three which are complete phone-CW rigs. 20-N for 20-watt and 60-P for 60-watt multi-band operation. 110-CM for Cathode-Modulation multi-band operation.

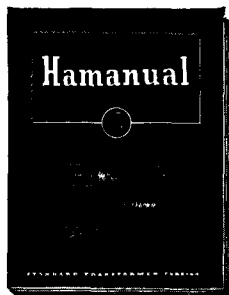

NOW! THE FIFTH EDITION HAMANUAL

The Fifth Edition Hamanual contains complete information on all of the units shown above plus many more. All transmitters and amplifiers in the Hamanual have been thoroughly tested under actual working conditions for long periods of time to assure maximum performance. In addition, the Hamanual contains a section on Audio amplifiers, Gadgets, Power Supply kits and many other subjects of interest and value.

We recommend that every user of amateur, commercial or P. A. transformers secure a copy of this valuable book. Price 15c—available from your regular Stancor jobber.

Request Fifth Edition Hamanual.

ASK YOUR NEAREST STANCOR DISTRIBUTOR OR WRITE FOR HIS NAME



STANDARD TRANSFORMER

• CORPORATION •

1500 NORTH HALSTED STREET . . . CHICAGO

S₁—From Centralab "Switchkit"
 S₂, S₃—Mallory-Yaxley 8
 S₄—Centralab 1461
 S₅—Centralab 1462
 S₆—Mallory-Yaxley 6-9
 S₇—Centralab 1460
 Tubes—RCA
 Dial—Crowe 525
 Control Knobs—Meissner 25-8222

Figure 16, page 143

Power Supply for Advanced Receiver

T—Stancor P-6014
 CH₁, CH₂—Stancor C-1001
 C₁, C₂—Solar DA-0616
 R—Ohmite "Brown Devil"

Figure 20, page 147

Battery Powered Converter

C₁—Cardwell ZR-50-AS
 C₂—Cardwell ZR-35-AS
 C₃—Cardwell ZU-100-AS
 C₄, C₅—Cornell-Dubilier 5W-5T1
 C₆, C₇—Cornell-Dubilier DT-6S1
 C₈—Bud 833 trimmer
 R₁, R₂, R₃—Centralab 710
 L₁—Meissner 16-8100
 L₂—Meissner 17-8175
 S₁, S₂—Arrow H&H s.p.s.t.
 A battery—Burgess 2F
 B battery—Burgess A30
 Coil forms—Bud 595 and 596
 Dial—Crowe 123M
 Tubes—RCA miniature
 Chassis—Bud CB-41
 Cabinet—Bud C-973

HENRY RADIO SHOP

• Butler, Missouri •

Our experience selling every model amateur receiver, of all makes, enables us to help you get the best set for your use. We are the *World's Largest Sellers of Amateur Receivers and Transmitters* because we make it to your advantage to buy from us.

You get best trade-in for your receiver. Get our offer.

I finance all terms myself so that I can give you better terms with less cost—less red tape—quicker shipment. Write me for terms.

You get ten days free trial of any receiver. Immediate shipment from our world's largest stock or shipment from the factory if you prefer.

So send to me for any amateur equipment in any catalog or advertisement. I guarantee you can't buy for less or on better terms elsewhere. We have all Stancor, Thordarson, other kits and can supply them wired ready to use. Write me about your needs and wishes. Tell me what you want and how you want everything handled.

73,

Bob Henry
 WBARA

P.S.: We have Reconditioned Guaranteed Receivers and Transmitters of nearly all models cheap. Terms and ten day free trial on these, too. Write for free list.

Figure 23, page 148

High Gain Preselector

C₁, C₂—Bud type 903
 Cabinet—Bud 870
 Coil sockets—Hammarlund S5
 Tuning dial—Crowe 124
 Tubular condensers—Cornell-Dubilier "Dwarf Tiger"
 Shaft coupling—Bud 795
 Tube—RCA

CHAPTER 12

EXCITERS AND LOW POWER TRANSMITTERS

Figure 2, page 251

One-Tube Exciter

C₁, C₂—Cardwell ZR-50-AS
 C₃—Aerovox 1450
 C₄, C₅, C₇—Aerovox 684
 R₁—Centralab 516
 R₂, R₃, R₄—Ohmite Brown Devil
 RFC—Bud 920
 X—Bliley LD2
 Coil Forms—Hammarlund XP-53
 Tube—Taylor T21

Figure 3, page 251

Power Supply for Figure 2

T—Thordarson T-13R13
 CH—Thordarson T-57C53
 C—Sprague LR-88
 R—Ohmite "Brown Devil"

Figure 6, page 253

V.F.O. Exciter

C₁, C₂—Bud type MC-1857
 C₃, C₄, C₇, C₉, C₁₀, C₁₁—Aerovox 484
 C₅—Aerovox 484
 C₆—Centralab 816-Z 350
 C₈—Aerovox 634
 R₁, R₂—Centralab 714
 R₃, R₄, R₅—Ohmite "Brown Devil"
 R₆—Centralab 516
 S—Bud SW-1005
 RFC—Hammarlund CH-8
 Tubes—RCA
 Jacks—Mallory-Yaxley 702-A
 Panel—Bud PS-1202
 Chassis—Bud CB-997

Figure 10, page 256

Cascade Frequency Multiplier

C₁, C₂—Cardwell ZR-35-AS
 C₃, C₄—Cardwell ZR-25-AS
 C₅ to C₁₂—Solar type MW
 R₁ to R₆—Centralab 516
 R₇—Ohmite "Brown Devil"
 S₁—Bud SW-1005
 S₂—Centralab 1405
 Chassis—Bud CB-997
 Panel—Bud PS-1202
 Tubes—RCA throughout

Figure 15, page 259

814 Bandswitching Exciter

R₁, R₂, R₃—Ohmite "Brown Devil"
 R₁₃, PC—Ohmite P-300
 C₁—Cardwell EU-140-AD
 C₂—Cardwell EU-100-AD
 C₃—Cardwell MT-100-GS
 C₄ to C₁₃—Solar MO and MW
 C₁₄—Solar XM-25-22
 C₁₅—Cardwell JD-50-OS
 M₁, M₂—Triplett 227-A
 T₁—Kenyon T-351
 T₂—Kenyon T-365
 Coil turret—Barker & Williamson type 2-A
 S₁—Centralab 1461
 S₂—Centralab 1460
 S₃—Heintz & Kaufman 892
 S₄—Mallory-Yaxley 151-L

DUNCO RELAYS for AMATEUR USE



As specialists for many years in the production of highest quality relays and timers, Dunco offers a complete line of standard and special types engineered for specific requirements. We welcome the opportunity to cooperate with you in supplying suitable units for any application.

(1) DUNCO RADIO RELAY

Isolated contacts permit operation in high or low voltage circuits at any frequency. No feedback or hum. Unit is designed for extremely fast operation. Unexcelled for bug keying. Low contact resistance; single break contacts; high voltage and current carrying and breaking capacity. Vibration-proof construction makes the relay suitable for use on autos, trains, planes, elevators, boats, etc.

Type	Operates On	Amateur Net
RA1	2.5 V. 60 Cycle Coil.....	\$2.00
RA2	2.5 V. 25 Cycle Coil.....	2.00
RA3	6.3 V. 60 Cycle Coil.....	2.00
RA15	115 V. 60 Cycle Coil.....	3.50
RD1	5 to 6 V. D.C. Coil.....	2.00
RD15	10 to 12 V. D.C. Coil.....	3.00

(3) DUNCO TIME DELAY RELAYS

By connecting input terminals across primary of filament transformer, and output terminals to primary of plate transformer, power is delivered to the latter 30 seconds after filaments are turned on, thereby prolonging tube life. Unit has snap-on housing with panel mounting as illustrated for back-of-panel connection. Contacts rated 6 amps. at 115 v., a.c. 3" high, 2 1/2" wide, 2 1/8" deep inc. cover.

Dunco Type-TD-327, Amateur Net \$8.80

Other Time Delays and Time Controls available.
Tell us your requirements.

(4) DUNCO MERCURY PLUNGER RELAY

This power type relay handles loads up to 30 amperes at 110 volts a.c. or 20 amperes at 220 volts a.c. Unexcelled for remotely controlled transmitters, receivers, motors, etc. The mercury tube is of the plunger type with only one moving part. It is completely silent in operation. Due to the use of mercury contacts, there is no sticking or burning of contacts. Standard coils operate on 115 volts, 60 cycles, but other coils are available. Vertical panel mounting. Size 3 1/4" high x 2 1/4" wide x 2 1/4" deep.

Dunco Type MR-1, single pole, Amateur Net, \$6.00

(2) DUNCO MIDGET KEYING RELAY

A high quality relay for speeds up to 40 w.p.m. Silver button replaceable contacts will interrupt currents of 6 amps. at 110 v., a.c. Contacts are single pole, and close when coil is energized. Consumes 50 ma. at 110 v., 60 cycles. Vertical panel mounting. Handles loads to 660 watts. 2 1/4" high, 1 1/8" wide, 1 1/4" deep.

Dunco Type ASBX1, Amateur Net \$3.75

NOTE: Dunco makes many other Midget Relay Types which are described in detail in our general catalog. Among these are: ABTX1 S.P.D.B. Front Contact, \$3.75, ABTX1P S.P.D.B. Front Contact with pigtail, \$4.00; ADBX1 D.P.S.B. Front Contact, \$4.75; BSBX1 S.P.S.B. Back Contact, \$3.75; CSBX1 S.P.S.B. Double Throw, \$4.00; and CDBX1 D.P.S.B. Double Throw, \$5.25 amateur net. These do not operate as fast as Type ASBX1.

(5) DUNCO RADIO FREQUENCY RELAY

Developed for use with low power transmitters. Contacts are double pole, double throw rated 6 amperes at 500 volts R.F. Mounted on micaalex base and a micaalex crossarm insulates the moving contacts from armature. Vertical mounting. Standard coil operates on 115 volts, 60 cycles, consumes 4 watts. Other voltage coils available. Size 3" high x 2" wide x 2 1/4" deep.

Dunco Type CXA1946, Amateur Net \$5.25

(6) DUNCO VACUUM TUBE RELAY

An ultra-sensitive unit specifically designed for operation in plate circuits of small tubes. Takes d.c. in coil circuit and either d.c. or a.c. in contact circuit. S.P., D.T. contacts make one circuit when coil is energized, and another circuit when de-energized. Coil has 4600 ohms resistance. Handles up to 18 ma. Unit may be adjusted for operation down to 1.32 ma. Contacts rated 2 amps. at 110 v., a.c. 2 1/8" high, 2 1/4" wide, 2" deep.

Dunco Type SD4052, Amateur Net, \$6.00

Write for details on Dunco sequence, ratchet or "step-by-step" relays.

THE DUNCO CATALOG is your guide to better relays. Lists the full line of standard and special Dunco relays and contains a wealth of engineering and application information. Write for your copy.



STRUTHERS DUNN · Inc.

1331 CHERRY STREET · PHILADELPHIA · PA.

Crystals—Bliley B5 and LD2
Tubes—RCA throughout

CHAPTER 13

MEDIUM AND HIGH POWER AMPLIFIERS

Figures 1 and 4, pages 263 and 265
400-Watt Amplifier

- C₁—Hammarlund MCD-100-S
- C₂—Hammarlund HFBD-65-E
- C₃, C₄—Hammarlund N-10
- C₅, C₆—Aerovox 1450
- L₁—Barker and Williamson MCL Series
- L₂—Barker and Williamson TVL Series
- Tubes—Eimac

Figures 1, 2 and 3, pages 263 and 264
"Accordion Coil" Amplifier

- C₁—Hammarlund MCD-35-MX
- C₂—Eimac vacuum type
- T—Thordarson T-74-F23
- Fil. meter—Triplett 237
- Tubes—Eimac
- R₁—Ohmite 50W

Figures 1 and 5, pages 263 and 266
1-KW. Amplifier

- C₁—Bud 1576
- C₂—Bud 1818
- C₃, C₄—Bud 1000
- C₅, C₆—Solar XM-6-24
- L₁—Bud VCL Series
- L₂—Bud MCL Series
- RFC—Bud 568
- Sockets—Bud 226
- Tubes—Taylor

Figures 1 and 6, pages 263 and 267

- C₁—Johnson 150FD20
- C₂—Johnson 150DD70
- C3, C4—Johnson 6G70
- RFC—Johnson 752

Tube sockets—Johnson 211

- L₁ socket—Johnson 225
- L₂ supports—Johnson 67
- L₃ coil jacks—Johnson type 70
- L₃ coil plugs—Johnson type 71
- Control handles—Johnson 204
- Tubes—H & K type HK-254

Figures 7, 8 and 9, pages 268, 269 and 270
Single-Ended Amplifier

- C₁—Cardwell MT-100-GS
- C₂—Cardwell XG-50-XD
- C₃—Bud 1519
- C₄, C₅, C₆—Aerovox 1450
- C₇—Aerovox 1457
- L₁—Barker and Williamson BL Series
- L₂—Barker and Williamson HDVL Series
- R—Ohmite 50 Watt
- RFC—Hammarlund CH-500
- T—Thordarson T-19F96
- Socket—Johnson 213

CHAPTER 14

SPEECH AND MODULATION EQUIPMENT

Figure 3, page 273
25-Watt Modulator

- Tubular condensers—Aerovox 484
- C₃, C₆—Aerovox PR5450 12 μ fd.
- C₃—Aerovox 1467 mica
- C₅, C₇—Aerovox PB-10-10 25 volt
- C₉—Aerovox 600-LU 4 μ fd.
- C₁₀—Aerovox GL-475 8 μ fd.
- Carbon resistors—Centralab 1 watt
- Wirewound resistors—Ohmite "Brown Devil"
- R₁—Mallory-Yaxley M control
- T₁—Stancor A-4721
- T₂—Stancor A-3892
- T₃—Stancor P-3005
- CH—Stancor C-1001
- Bias cell—Mallory-Yaxley
- Tubes—RCA throughout

Figure 5, page 275

60-Watt T-21 Modulator

- C₁, C₄—Solar S-0240
- C₂—Solar S-0215
- C₃, C₇—Solar S-0263
- C₁₃, C₁₄, C₅, C₁₅—Solar LG5 8-8
- C₁₁, C₁₂—Solar M116
- C₆—Solar M010
- R₁—Centralab 72-116
- All 1/2-watt resistors—Centralab 710
- All 1-watt resistors—Centralab 714
- R₁₉, R₁₆, R₂₁—Centralab 516
- R₁₇, R₁₈, R₁₉, R₂₀—Ohmite "Brown Devil"
- BC—Mallory-Yaxley Bias Cell
- T₁—Thordarson T-84D59
- T₂—Thordarson T-11M75
- T₃—Thordarson T-79F84
- T₄—Thordarson T-84P60
- CH₁—Thordarson T-75C49
- CH₂—Thordarson T-75C51
- CH₃—Thordarson T-68C07
- Tubes—RCA 6J5, 6L7, 83, 45, Taylor T-21

Figure 9, page 278

6-Watt 6L6 Grid Modulator

- C₁, C₄, C₇—Cornell-Dubilier EDJ-3100
- C₃, C₅, C₆—Cornell-Dubilier BR-845
- C₂—Cornell-Dubilier DT-681
- C₈—Cornell-Dubilier DT-4P1
- C₉—Cornell-Dubilier SM-6S5
- 1-watt resistors—Centralab 714
- 1/2-watt resistors—Centralab 710
- R₁₂, R₁₃, R₁₄—Ohmite "Brown Devils"
- R₅—Centralab 72-105 potentiometer
- T₁—Stancor A-4406
- T₂—Stancor P-3005
- CH—Stancor C-1421
- Feed-thru insulators—Bud I-436
- Chassis—Bud CB-1194
- Pilot light—Mallory-Yaxley 310R
- Tubes—RCA throughout

RELAYS BY STACO

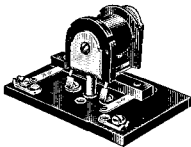

* RBA-1:— General Purpose and R. F. SPST (double break), 110 v. AC, 4 ampere pure silver contacts, \$1.65 net.

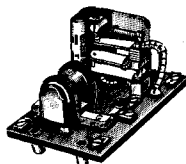

* TD-11:— Adjustable time delay 5 sec. to 1 min., Room Temperature Compensator, 110v. AC. \$6.45 net.



Communication Relays:— Sensitive DC relays, 250 to 10,000 ohms coils. 3/16" pure silver contacts. \$2.00 to \$2.70 net.

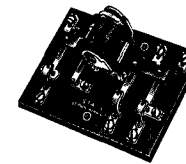

* BBA—R.F. Break-in Relay, 3/16" pure silver contacts, 110 v. AC coil, \$4.20 net. Other units from \$2.55 to \$6.00.

SEE YOUR JOBBER OR WRITE FOR CATALOG

Standard Electrical Products Co.

316 Sibley St.

St. Paul, Minnesota

These McGRAW-HILL Books will help make 1941 a better year for you!

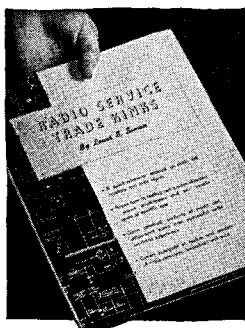

RADIO SERVICE TRADE KINKS

By Lewis S. Simon. This is one service manual it will pay you to use. It gives blunt, step-by-step directions for finding troubles and for fixing them. Some of the methods are homely trade kinks that have never before been known except to a few expert service men. Every trouble solution has been checked again and again. Every page of directions may be depended upon.

The book points out the weak points of radio receivers of specific makes and models, and so enables you to go right to that point to spot the trouble. It will save you hours of time and give you satisfied customers. 269 pp., spiral-bound, \$3.00.

UNDERSTANDING RADIO

By Watson, Welch and Eby of Stockton Junior College. This book covers the radio field for the radio new-comer who knows nothing about radio art and little about electricity. As he studies the text, builds the equipment, and performs the tests, he acquires a knowledge of radio principles and how they are put into practice. He gains confidence, as he deals with sets and circuits, from the simple, clear explanations of electrical and radio principles involved in their operation. 601 pp., 406 illus., \$2.80.

See any of these books under one of these offers: (1) Send name, address, and business identification for a copy on approval, subject to remittance, plus few cents postage, or return of book ten days after receipt. (2) Books sent postpaid for cash with order, subject to return and refund in 10 days if you are not satisfied.

RADIO OPERATING QUESTIONS & ANSWERS

New 7th Edition

By Nilson and Hornung, Radio Engineers. A famous book for those preparing to take radio operator license examinations, giving nearly 1,300 questions on radio communication—theory, apparatus, circuits, laws and regulations,—together with full, correct answers for review and study. Helps the beginner and the experienced operator seeking advancement, to check their training and knowledge and to focus on the key points of theory and practice as covered in new Government procedure and requirements for examinations. 398 pp., \$2.50.

Principles of TELEVISION ENGINEERING

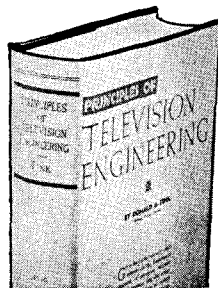

By Donald G. Fink,
Managing Editor *Electronics*.

Here is the television of 1941, in ten fact-packed chapters that cover fundamental principles, design, and equipment. The whole process is carefully investigated, from studio camera right through to the receiver screen image, with a thorough exposition of basic theory and today's practice. In logical sequence the book presents the camera, amplifying and transmitting equipment, radiation through space, reception and amplification, detection, and image reproduction. 541 pp., 313 illus., \$5.00.

FRANK DICKMAN

330 West 42nd Street

New York City

Figure 11, page 280

Push-Pull 2A3 Amplifier-Driver

- C₁₁, C₃, C₅—Aerovox 484
- C₂₀, C₇—Aerovox PBS-25 10
- C₄₁, C₇—Aerovox PBS-5 8-8
- C₈₁, C₉—Aerovox WG-5 8
- R₁₁, R₂, R₃, R₄—Centralab 710
- R₅—Centralab 72-105
- R₆—Centralab 710
- R₇, R₉—Ohmite Brown Devil
- Input trans.—Stancor A-72-C
- T Stancor P-4049
- CH—Stancor C-1421
- Tubes—RCA throughout

Figure 13, page 281

Class B 809 Modulator

- T₁—Stancor A-4762
- T₂—Stancor A-3894
- T₃—Stancor P-3064
- M—Triplet no. 221A
- Tubes—General Electric

Figure 16, page 283

TZ-40 Modulator

- T₁—Thordarson 81D42
- T₂—Thordarson 15D79
- T₃—Thordarson 11M77
- T₄—Thordarson 70R62
- T₅—Thordarson 16F13
- CH₁—Thordarson 74C29
- CH₂—Thordarson 13C28
- All tubular condensers—Cornell-Dubilier DT
- All filter condensers—Cornell-Dubilier EDJ
- Tubes—RCA. TZ-40's Taylor

Figure 18, page 285

203Z Modulator

- All tubular condensers—Cornell-Dubilier DT

All resistors—I.R.C. BT-1/2 and BT-1

- R₇—Mallory-Yaxley O control
- R₁₄—Mallory-Yaxley Y50MP
- T₁—Thordarson T-57A41
- T₂—Thordarson T-75D10
- T₃—Thordarson T-11M77
- T₄—Thordarson T-19F96
- M—Triplet 221A
- 203Z—Taylor, Rest—RCA
- Sockets for 203Z—Johnson 211

CHAPTER 15

POWER SUPPLIES

Figure 13, page 298

Voltage Regulated Supply

- T—Kenyon T-206
- CH—Kenyon T-154
- C₁, C₂—Sprague type TC
- C₃, C₄—Sprague UT-16
- R₃—Centralab W-32
- Tubes—Hytron

Figure 24, page 302

350-Volt Power Supply

- T—Thordarson T-13R14
- CH—Thordarson T68C07
- C—Cornell Dubilier EH-9808
- R—Ohmite Brown Devil
- 83—Hytron

Figure 26, page 303

500 Volt Power Supply

- Transformers—Stancor P-3699 and P-5009
- Chokes—Stancor C-1401 and C-1411
- Condensers—Cornell Dubilier TLA-6040
- 83—Hytron

Figure 27, page 303

Rack Mounted Supply

- Transformers—Kenyon T-Line
- Chokes—Kenyon T-Line
- Bleeders—Ohmite Dividohm
- 866's—General Electric
- Condensers—Cornell Dubilier TJU-200-20 and PE-CH-4008

Figure 30, page 307

Modulator and Power Supply

- Transformers—Kenyon T-Line
- Chokes—Kenyon T-Line
- TZ-40's—Taylor
- 866's—Taylor
- Ma.—Triplet 227-A
- Condensers—Aerovox

Figure 31, page 309

Dual Power Supply

- Transformers and Chokes—Thordarson "19" Type
- Tubes—GL-866 and RCA 83
- Condensers—Mallory

Figure 32, page 310

Compact Power Supply

- Transformers and Chokes—Thordarson "CHT" type
- Condensers—Aerovox
- Bleeders—Ohmite "Dividohm"
- Tubes—RCA-866

CHAPTER 16

TRANSMITTER CONSTRUCTION

Figure 4, page 315

Exciter-Transmitter R.F. Section

- C₁₁, C₂—Hammarlund MC-325-M
- C₃—Hammarlund MTC-25-C
- C₄₁, C₅₁, C₆—Sprague TC-11
- C₇—Sprague 1FM-21
- C₈, C₉, C₁₂, C₁₃—Sprague 1FM-24
- C₁₀—Sprague 1FM-35
- R₁₁, R₂₁, R₄, R₆—Ohmite Brown Devil
- R₃₁, R₅, R₇—Centralab 516
- RFC₁₁, RFC₂₁, RFC₃—Hammarlund CHX
- S₁—Centralab 1462
- X—Billey LD2
- 6L8's—RCA
- HY-69—Hytron
- Bias Battery—Burgess B30

MAILING LISTS

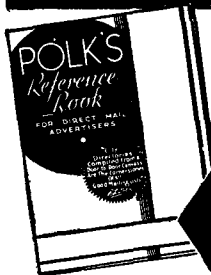

GET OUR FREE REFERENCE BOOK and MAILING LIST CATALOG

FREE

Gives counts and prices on accurate guaranteed mailing lists of all classes of business enterprises in the U. S. Wholesalers—Retailers—Manufacturers by classification and state. Also hundreds of selections of individuals such as professional men, auto owners, income lists, etc.

Write today for your copy

R. L. POLK & CO.

Polk Bldg.—Detroit, Mich.

Branches in Principal Cities

World's Largest City Directory Publishers
Mailing List Compilers. Business Statistics. Producers of Direct Mail Advertising.

5 BIG ISSUES FOR \$1



For all new subscribers or those who have not been on our subscription lists during the past year, we make this introductory offer of *five big issues of RADIO for only one dollar!* This rate is good in U.S.A. only (elsewhere, half the one-year rates quoted below).

Here's the magazine that's known the world over as the authority of practical and technical radio. Every issue is packed with easy-to-understand and profusely illustrated text written by our own editors—and as RADIO pays for technical and constructional material, we publish the “cream of the crop” from outside authors.

Take advantage of this introductory offer by acting now. We'll send you the *next five issues of RADIO* for only one dollar!

\$2.50 yearly

(U. S. A.)

Two years **\$4.50**

To Canada (inclusive of current taxes), Newfoundland, Pan-American countries, and Spain, add 50c per year. Elsewhere add \$1. per year. Illinois customers: please add sales tax.

THE EDITORS OF
RADIO *technical publishers*

1300 Kenwood Road, Santa Barbara
CALIFORNIA

- Coil Turret—Bud XCS-1
- Chassis—Bud 772
- Panel—Bud 1254
- Panel Brackets—Bud 460
- Cabinet—Bud CR-1743
- Meters—Triplet 227A

Figure 6, page 316
Speech Amplifier-Modulator

- C₁—Sprague 2FM-31
- C₂, C₇—Sprague TA-10
- C₃—Sprague TC-11
- C₄—Sprague TC-2

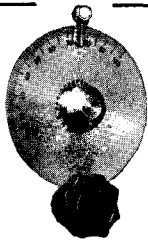

RADIOCRFTER DIALS

Lead the field with their smooth, non-slip friction drive, handsome roto-buffed electro-etched nickel silver disc and reputation for dependability. Used on marine, plane and portable commercial equipment, yet priced low enough for use on low-cost experimental gear.

4" VERNIER DIAL \$1.20 NET WITH KNOB

AND COMPLETE LINE OF DIALS, DISCS, KNOBS SWITCHES, PANELS, LACQUER, COIL FORMS, ETC

5 BAND SWITCH-COIL KIT REPLACES PLUG-IN COILS

Now you can design your own tuning unit for receiver, exciter, preslector, etc. at a big saving! Use our turn-per-inch inductance table reading in microhenries with simple L/C formula.

Sold Only by Radiocrafter Distributors

Send 20c for 5-1/2"x2" polystyrene fibre coil forms and winding instructions. Offer made to popularize the convenience and efficiency of "C" forms.

RADIOCRFTERS

1156 Commonwealth, Brookline, Mass.

CATALOG FREE

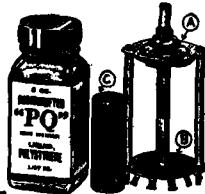

- C₈, C₉, C₁₁—Sprague UT-8
- C₆, C₉—Sprague TC-15
- C₁₀—Sprague TA-510
- R₁ to R₉, inclusive—Centralab 710
- R₇, R₈, R₉—Centralab 714
- R₁₀—Centralab 72-121
- R₁₁, R₁₂—Centralab 516
- R₁₃—Ohmite Brown Devil
- T₁—Kenyon T-254
- T₂—Kenyon T-493
- T₃ Driver Transformer—Kenyon T-271
- 6SJ7, 6J5, 6V6—RCA
- 6A3—Hytron
- Chassis—Bud CB-1762
- Panel—Bud 1254

Figure 7, page 317
Power Supply

- T₁—Kenyon T-655 (Use "low" pri. tap).
- T₂—Kenyon T-367
- CH₁, CH₂—Kenyon T-153
- CH₃—Kenyon T-152
- C₁, C₂—Sprague PC-46
- C₃, C₄—Sprague SC-8
- C₅—Sprague UT-161
- R₁, R₂—Centralab 516
- R₃, R₄—Ohmite Brown Devil
- Tubes—Hytron

Figure 9, page 318
R. F. Amplifier and Modulator

- C₁—Bud 912
- C₂—Bud BC-1629
- C₃, C₄, C₅—Aerovox 1450
- C₆, C₇—Bud MC-567
- C₈—Aerovox 1457
- C₉, C₁₀—Aerovox 1509
- R₁, R₂—Ohmite Brown Devil
- R₃, R₄, R₅—Centralab 714
- RFC—Bud 569
- L₁—Bud OLS Series
- L₂—Bud VLS Series
- L₃ Coupling and Jack Assembly—Bud AM-1352
- T₁—Stancor A-3894
- T₂—Stancor P-6309
- T₃—Stancor P-3060
- T₄—Stancor P-6152
- RY—Staco T-10E
- S₁—Centralab 2542
- S₂—Bud 1270
- PC—Ohmite P-300
- 811's—General Electric
- 812's—General Electric
- R.F. Chassis—Bud 643
- Modulator and Power Supply
- Chassis—Bud CB-1762
- Cabinet—Bud CR-1744
- Modulator and Power Supply
- Panel—Bud 1256
- R.F. Panel—Bud 1257
- 812,866 Sockets—Johnson 210
- Feed Through Insulators—Johnson 44
- Meters—Triplet 326
- 866's—General Electric

Figure 17, page 324

- 35-T Cathode-Modulated Phone
- Carbon resistors—Centralab 710 and 714
- Wirewound resistors—Ohmite "Brown Devil" and "Dividohm"
- R₁₀, R₁₁—Mallory-Yaxley Standard Universal
- C₂—Bud 903
- C₄, C₅, C₉, C₁₀—Cornell-Dubilier type 9
- C₆—Bud type 1540
- C₇—Bud type NC-890
- C₁₁—Bud type 1559
- C₁₂—Bud types 780 and 781
- C₁₅—Mallory-Yaxley TX808
- T₁—Thordarson T-70R78
- T₂—Thordarson T-19F83
- T₃—Thordarson T-19F90
- T₄—Thordarson T-19P60

"RADIO" AMATEUR NEWCOMER'S HANDBOOK

Really two complete books under one cover, the big "Radio" Amateur Newcomer's Handbook contains everything needed to obtain a

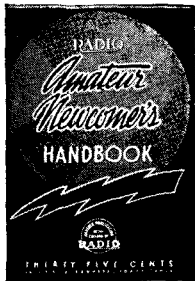

license and get on the air!

Easy - to - understand data on elementary radio theory (simplified), radio laws and regulations; how to learn the code; how to pass the amateur examination (including Editor's notes on new F.C.C. examination questions); detailed construction data

on simple receivers; a low-powered c.w. transmitter; and a beginner's phone transmitter.

Order from your favorite radio dealer, newsstand, or direct from us postpaid.

35c in U.S.A., Elsewhere 40c

T₅—Thordarson T-70R62
 T₉—Thordarson T-19F84
 T₇—Thordarson T-17S15
 CH₁—Thordarson T-16C07
 CH₂₉, CH₃—Thordarson T-75C51
 CH₄—Thordarson T-17C00-B
 35T₅—Eitel McCullough
 866's—General Electric
 Other tubes—RCA
 X—Bliley type VF-1
 RFC₁ to RFC₄—Bud type 920
 RFC₅—Bud type 568
 Cabinet, chassis and panels—Bud
 Figure 21, page 328
 250-Watt C.W. Transmitter
 C₁, C₂—Cardwell ZR-50-AS
 C₃—Cardwell ZR-35-AS
 C₄—Cardwell ZT-15-AS
 C₅₇, C₆—Cardwell MT-70-GS
 C₇₇, C₈₁, C₉, C₁₀—Aerovox 1467
 C₁₁₁, C₁₂₁, C₁₃—Aerovox 1450
 C₁₄ to C₂₁, inclusive—Aerovox 1467
 C₂₂—Aerovox 1457
 C₂₃—Cornell-Dubilier BR-255
 C₂₄, C₂₅—General Electric Pyranol
 R₁, R₂, R₃, R₄, R₅—Centralab 710
 R₆—Centralab 714
 R₇ to R₁₄, inclusive—Centralab 516
 R₁₅, R₁₆, R₁₇, R₁₈—Ohmite Brown Devil
 T₁—Thordarson T-19F96
 T₂—Thordarson T-19F76
 T₃—Thordarson T-84P60
 CH₁₁, CH₂—Thordarson 75C51
 RFC₁, RFC₂—Hammarlund CHX
 S₁—Centralab 2543
 S₂—Centralab 2505
 Chassis—Bud 733
 Panel—Bud 1593

Panel Brackets—Bud 460
 813—General Electric
 Other tubes—RCA
 813 Socket—Johnson 237
 Crystal—Bliley LD2
 Figure 29, page 334
 400-Watt Phone Transmitter
 All variable condensers—Bud
 All mica fixed condensers—Cornell-Dubilier type 9
 All paper by-pass condensers—Solar Domino
 Electrolytic condensers—Mallory-Yaxley
 Ceramic sockets—Hammarlund type S
 All wirewound resistors—Ohmite
 All carbon resistors—Centralab Insulated type
 Tubes—Heintz & Kaufman HK254's or Eimac
 100TH's, Heintz & Kaufman HK54 or Eimac
 35T, Taylor 203Z's. All others RCA
 RFC—Bud type 920
 RFC₅—Bud type 569
 R₁₅, R₂₁—Yaxley universal type
 Tuning dials—Bud type 165
 Coil Forms—Bud type 126
 C₃₈, C₃₄, C₃₅—Mallory oil type
 T₁—19F83
 T₂—19F85
 T₃—33A91
 T₄—75D10
 T₅—T-1177
 T₆—T-75R50
 T₇—T-19F96
 T₈—T-19P59
 T₉—T-19F90
 T₁₀—T-19P62
 T₁₁—T-19F90
 CH₁, CH₂—T-19C42
 CH₃—T-19C36
 CH₄—T-19C43
 CH₅—T-19C36

PAR-METAL

Stands for Quality

When you buy Par-Metal parts you buy more than merely metal. You get streamlined beauty, handsome finish, chromium trim. You get parts which have been accurately machined for easy assembly. Quality Parts such as these give your finished job the look of commercially built equipment.

Chassis • Cabinets • Racks • Panels

Par-Metal Parts Are Available in Both Standard and DeLuxe Qualities

Catalog No. 40 describes our complete line. At your jobber or write direct.

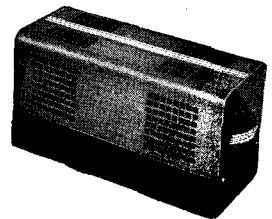
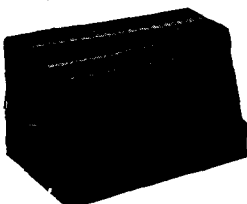
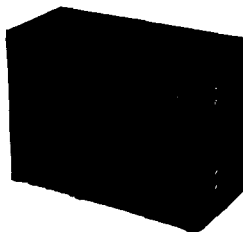
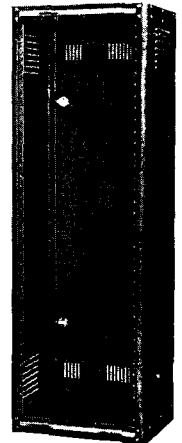
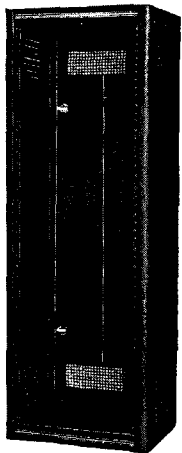

PAR-METAL PRODUCTS CORP.

3262, 49th St. LONG ISLAND CITY, N. Y.
 Export Dept: 100 Varick St., New York, N. Y.

Crystal—Bliley LD2 or B5
 HK-54—Heintz and Kaufman Ltd.
 HK-254's—Heintz and Kaufman Ltd.
 Other tubes—RCA

CHAPTER 18

U.H.F. RECEIVERS AND TRANSCEIVERS

Figure 2, page 351

Five and Ten Meter Converter

C₃₁, C₃₂—Rebuilt Cardwell ER-25-AD, see text
 C₃₃, C₃₄—Cornell-Dubilier 1W-5S1



HANDI-MIKES FOR THE AMATEUR

Universal's new handi-mike for small transmitters, sound equipment, etc. Clear, crisp voice reproduction. Bal. grip, pol. chrome plate, snap switch, 6 ft. flex. cord. Choice of circuits and switches, single and double button carbon, crystals, dynamics in all impedances. At your dealer or jobber.

Universal also manufactures over 100 models and types of microphones, stands and accessories: recording machines, blank discs, lead screws, cutting heads, needles, styli and the new UNIVERSAL RECORDER KIT.

UNIVERSAL MICROPHONE CO., Ltd.
 Inglewood Calif., U. S. A.

RADIO BINDER

Keep your copies of RADIO and your big "Radio" Handbook in this handsome binder!

Holds a full year's copies of RADIO and the "Radio" Handbook, in addition to one smaller book by the Editors of RADIO. Each book or magazine may be inserted or removed at will and the sturdy, red imitation leather binding which is embossed in gold, will last a lifetime!

1.50 in Continental U. S. A. Elsewhere, **1.75**

THE EDITORS OF
RADIO 1300 Kenwood Road, Santa Barbara
 CALIFORNIA

C₄₁, C₄₂—Cornell-Dubilier 5W-5T5
 C₄₃—Meissner 22-7002
 C₄₄—Hammarlund APC-25
 C₄₅—Hammarlund HF-15
 C₄₆—Cornell-Dubilier EDJ-9080
 R₁₁, R₅—Centralab 710
 R₂₁, R₃₁, R₄₁—Centralab 714
 Chassis and cabinets—Bud 870-A
 Tubes—RCA

Figure 5, page 353

UHF R/C Superhet

C₁—Hammarlund HF-15
 L₁—Ohmite Z1
 L₂—Hammarlund RFC-85
 Mica condensers—Cornell-Dubilier type 5W
 Tubular condensers—Cornell-Dubilier type DT
 Tuning dial—Bud type D-103-B
 R₂₁, R₇—Mallory-Yaxley Standard Universal
 Tubes—RCA throughout

Figure 9, page 356

FM-AM Superhet

C₁, C₂, C₃, C₄, C₁₂₁, C₁₇₁, C₁₈₁, C₂₈₁—Sprague 2FM-31
 C₁—Johnson 7J12
 C₂—Johnson 15J12
 C₃₁ to C₃₁₁ inclusive, C₁₃₁, C₁₄₁, C₁₅₁, C₁₉₁, C₂₁₁, C₂₈₁—
 Sprague TC-11
 C₁₀—Sprague 2FM-45
 C₂₀₁, C₂₇₁—Sprague TA-10
 C₂₂—Sprague TC-1
 C₂₃—Sprague TX45-35
 C₂₄₁, C₂₉—Sprague 2FM-35
 C₂₆—Sprague UT-8
 R₁₁, R₈₁, R₄₁, R₆₁, R₉₁, R₈₁, R₉₁, R₁₀₁, R₁₂₁, R₁₃₁, R₁₄₁, R₁₅₁, R₁₈₁,
 R₁₉₁, R₂₀₁, R₂₁₁, R₂₂₁, R₂₃₁, R₃₀—Centralab 710
 R₂₁, R₇₁, R₁₁₁, R₁₉₁, R₂₃₁, R₂₄₁—Centralab 714
 R₁₇—Mallory-Yaxley G
 R₂₇₁, R₂₈₁—Ohmite Brown Devil
 R₂₈—Mallory-Yaxley N
 T₁₁, T₂₁, T₃₁, T₄—Meissner 16-4261
 S₁—Mallory-Yaxley 8
 RFC—Hammarlund CHX
 Tubes—RCA throughout

Figure 12, page 360

112 Mc. Receiver

C₁—Johnson 7J12
 R₁₁, R₃—Centralab 710, 714
 R₂₁, R₄—Centralab Midget Radiohm
 R₅—Sprague 5-K Koolohm
 BC—Mallory Bias Cell
 T₁—Thordarson T-13A35
 Cabinet—Bud CU-728
 RFC—Bud CH-925

Figure 15, page 361

224 Mc. Receiver

C₁—Modified Cardwell Trim-Air
 C₂—Aerovox 1468
 C₃₁, C₄—Aerovox type 84
 C₅₁, C₆—Aerovox type PRS
 C₇—Aerovox 1467
 R₁₁, R₂₁, R₈—Centralab 710
 R₄—Centralab 714
 R₅—Centralab 72-122
 R₆—Ohmite "Brown Devil"
 T₁—Thordarson T-13A35
 HY615 and 6J5GT—Hytron
 6F6—RCA

Figure 17, page 362

112 Mc. Mobile Transceiver

C₁—Cardwell ZV-5-TS with unsplit stator
 C₂—Sprague 2FM-31
 C₃₁, C₄—Sprague TC

It's a Masterpiece

Took 5 years and thousands of dollars to develop the
MASTER CATALOG of the **RADIO INDUSTRY**
to its present size — — yet it costs you only **\$2.50.**

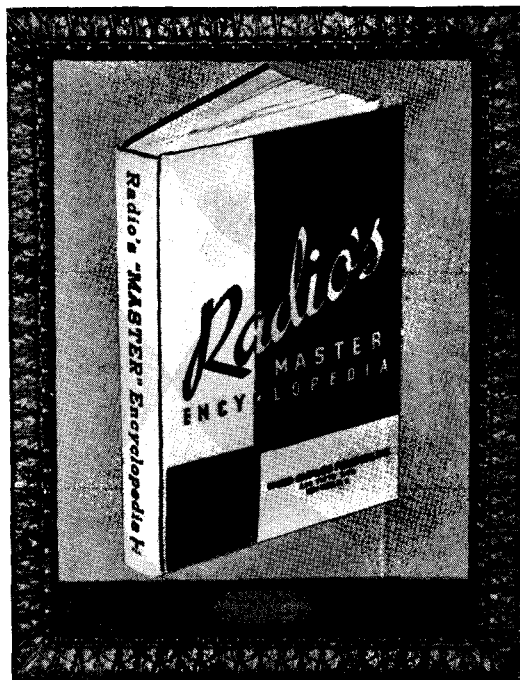

Bound in
one large
volume.

Replaces
bulky
files.

Completely
indexed.

Saves
Time
and Money.

Thousands
in use by those
who buy, sell
or specify.

Indispensable
for everyday
reference.

A handy book
to have
around
at all times.

1940-41 EDITION

Approved by and with the cooperation of the Radio Manufacturers' Group. This authentic source book is universally used by governmental agencies, industrials, purchasing agents, foreign organizations, amateurs, servicemen, schools, libraries, broadcasting stations and others interested in the radio equipment field.

Contained within the hard covers of this 750 page book are the listings of many thousands of items, such as, transmitting and receiving sets, tubes, antennas, transformers, condensers, replacement parts, instruments, test equipment, relays, wire, coils, plugs and numerous other radio classifications. Thousands of illustrations beautifully reproduced with complete

description and specifications makes this "THE RADIO MASTER ENCYCLOPEDIA" a "must" book. Price is \$2.50 in U. S. A. and \$3.00 elsewhere. Remittance with order saves you transportation charges. Order your copy TODAY and start the latest edition of RADIO'S MASTER ENCYCLOPEDIA on its way. Do it NOW.

UNITED CATALOG PUBLISHERS, INC.

230 Fifth Avenue
New York, N. Y.

C₆—Sprague TA-10
 C₆—Sprague UT-8
 R₁—Centralab 516
 R₂, R₄, R₅—Centralab 714
 R₃—Centralab 710
 R₃, R₆—Mallory-Yaxley type L
 RFC—Ohmite Z-1
 S₁—Centralab type 1450
 T₁—Thordarson T-72A59
 T₂—Thordarson T-13S38
 Power Sup.—Mallory Vibrapak

Figure 20, page 365
 Battery Transceiver

C₁—ZU-100-AS
 C₂—Cornell Dubilier type 1-W
 C₃, C₄—Cornell Dubilier DT-4P1
 C₆—Cornell Dubilier DT-4S1
 C₆—Meissner 22-5255
 R₂—Centralab Universal
 T—Thordarson 72-A-59
 CH—Thordarson T-14C61
 S₂—Centralab 1450
 Cabinet—Bud 999 with CB976 chassis
 Battery Pack—Burgess 4TA60
 Feed Through Insulators—Johnson type 42

CHAPTER 19 U.H.F. TRANSMITTERS

Figure 2, page 369
 HY75 112 Mc. Oscillator

C₁—Johnson 15J12
 C₂—Solar type MO
 RFC—Bud CH-925
 Tube—Hytron
 R₁—Centralab 516

NEW W.A.Z. MAP

The "DX" map by the Editors of "Radio" consists of the W.A.Z. (worked all zones) map which shows in detail the forty DX zones of the world under the W.A.Z. plan. This has become by far the most popular plan in use today for measurement of amateur radio DX achievement.

An additional feature of this new, up-to-date edition is the inclusion of six great-circle maps which enable anyone, without calculations, to determine directly the great-circle direction and distance to any point in the world from the base city for the map in use!

POSTPAID 35c ANYWHERE

Seven international postal reply coupons accepted
 as 35c

THE EDITORS OF
RADIO
 1300 Kenwood Road, Santa Barbara
 CALIFORNIA

Figure 4, page 371
 10 W. 112 Mc. Transmitter

T₁—Thordarson type T-86A02
 T₂—Thordarson T-17M59
 T₃—Thordarson T-70R62
 CH—Thordarson T-57C53
 C₁—Cornell-Dubilier type EDJ2250
 C₂, C₃—Cornell-Dubilier EH 9808 (one)
 R₁, R₂, R₃—Centralab 514
 R₄, R₅—Centralab 516
 Tubes—RCA
 M—Triplet 221

Figure 6, page 372
 75-T Oscillator

C₁—Bud MC-902
 C₂—Aerovox 1457
 C₃—Aerovox 1467
 C₄—Aerovox 1450
 R₁—Ohmite "Brown Devil"
 RFC—Bud CH-925

Figure 12, page 374
 P.P. 224 Mc. Oscillator

C₁—Cornell Dubilier 1-W
 R₁—Ohmite "Brown Devil"
 Tubes—Hytron

Figure 15, page 376
 829 224 Mc. Transmitter

C₁—Solar MO
 C₂—Solar MT
 R₂—Ohmite "Brown Devil"
 RFC₁—Ohmite Z-1
 HY-75—Hytron
 829—RCA

Figure 18, page 377
 56-Mc. Transmitter Exciter

C₁, C₂—Solar MP-4119
 C₃—Cardwell ZU-75-AS
 C₄—Solar MW-1239
 C₅—Solar MW-1216
 C₆—Solar MW-1210
 C₇—Cardwell ZR-50-AS
 C₈, C₁₀, C₁₁, C₁₃—Solar MW-1227
 C₉—Solar MW-1233
 C₁₂—Cardwell ZT-15-AS
 R₁, R₄, R₇—IRC "BT"
 R₂, R₃, R₅, R₆—Ohmite "Brown Devil"
 RFC—Bud 920
 Crystal—Bliley B-5
 Tubes—RCA 6L6, Taylor T21

Figure 20, page 380
 125-Watt Amplifier

C₁—Cardwell ET-30-ADI
 C₂—Cardwell NP-35-ND
 R₁—Ohmite "Brown Devil"
 J₁, J₂—Yaxley 702
 RFC—Johnson 760
 T—Thordarson, T-19F98
 Sockets—Hammarlund S-4
 Tubes—Heintz & Kaufman
 Bar Knobs—Crowe

Figure 21, page 381
 HK54 U.H.F. Amplifier

C₁—Hammarlund MCD-35-MX
 C₂—Aerovox 1467
 R₁—Ohmite 25W
 M₁, M₂—Triplet 321
 T—Kenyon T-357
 Tubes—Heintz and Kaufman

Figure 24, page 383
FM Transmitter
Exciter Chassis

- C₁—Cardwell ZU-75-AS
- C₂—Cardwell ZR-35-AS
- C₃—Cardwell ZR-25-AS
- C₄—Cardwell MT-20-GS
- C₅₁, C₆₁, C₇₁, C₈₁, C₉₁, C₁₀₁, C₁₁₁—Aerovox 1467
- C₁₂₁, C₂₄—Aerovox 484
- C₁₃₁, C₁₅ to C₂₂₁ inclusive—Aerovox 1467
- C₂₅—Aerovox—1496
- C₂₆—Aerovox PR-450
- C₂₇—Aerovox—MM-25
- C₂₇—Centralab 910-Z
- R₁₁₁, R₁₄₁, R₁₅₁, R₁₆₁, R₁₇₁—Ohmite "Brown Devil"
- R₂₂—Mallory-Yaxley
- S₁—Mallory-Yaxley 151L
- T₁—Thordarson 19F99
- T₂—Thordarson 14A90
- RFC—Bud 920
- Octal Steatite Sockets—Meissner 25-8439
- HK-24 Socket—Bud 954
- Pillar Insulators—Meissner 27-1013
- Tubes—HK-24. Balance RCA, Heintz & Kaufman
- M—Triplett 221

Output Stage Chassis, Figure 25

- C—Cardwell ER-50-AD
- R—Ohmite "Brown Devil"
- M₁, M₂—Triplett 326
- Tubes—Heintz and Kaufman
- Plate-Line Supporting Insulators—Johnson 67

Figure 29, page 387
815 FM Transmitter

- C₁₁, C₈—Bud LC-1682
- C₃—Bud LC-1662
- C₂—Bud LC-1661
- C₅—Dismantled Bud NC-890
- C₆₁, C₇—Sprague 1FM
- C₈—Centralab 910-Z
- C₉ to C₁₅—Sprague 1FM
- C₁₆—Sprague SM33
- C₂₀—Sprague UT-8
- C₂₁—Sprague TC
- C₂₂—Sprague 1FM
- C₂₃—Sprague TA-10
- R₁₁, R₂₁, R₃₁, R₅₁, R₆₁, R₂₂₁, R₂₃₁, R₂₄₁, R₂₅₁—Centralab 710
- R₄₁, R₇₁, R₈₁, R₁₀₁, R₁₇₁, R₁₈₁, R₁₉₁, R₂₀₁—Centralab 714
- R₆₁, R₁₃₁, R₂₁—Ohmite "Brown Devil"
- R₁₀₁, R₁₂₁, R₁₄₁, R₁₅₁—Centralab 516
- R₁₁—Mallory-Yaxley type N

A GIFT!

When you buy parts required for building equipment shown in this edition, remember that our advertisers have made possible the low cost of this book. Your thanks for this present can best be expressed by patronizing them whenever possible.

The Editors

- RFC₁, RFC₂—Hammarlund CHX
- RFC₃—Ohmite Z-1
- T—Thordarson T-19F99
- M—Triplett 326
- Meter Sw.—Mallory-Yaxley 151-L
- Tubes—RCA throughout

CHAPTER 22 TEST AND MEASURING EQUIPMENT

Figure 5, page 455
Frequency Spotter

- C₁₁, C₂—Hammarlund Star SM-100
- C₄₁, C₅—Solar type MW
- C₆₁, C₇—Solar type MP "Domino"
- C₈₁, C₉₁, C₁₀—Solar type MW
- C₁₁₁, C₁₂—Solar type MP "Domino"
- C₁₃—Solar type MW
- C₁₄₁, C₁₅—Solar D-820 electrolytic
- R₅₁, R₆—Ohmite "Brown Devil"
- S₁—Centralab 1465 switch
- L₁—Meissner 17-6753 b.f.o. coil
- T₁—Thordarson T-13R11

Figure 8, page 457
Dual Crystal Calibrator

- X—Bliley SMC-100
- L—Hammarlund CH-8
- L₁—Hammarlund CH-X (altered)
- C₁—Meissner 22-7002
- C₂, C₃, C₄—Solar "Sealdtite"
- C₆—Hammarlund SM-25
- C₇₁, C₈—One Solar LGS-44
- T—Thordarson T-13R01
- Tubes—RCA

THE "RADIO" NOISE REDUCTION HANDBOOK

Tells in simple language, how to eliminate or greatly reduce every form of radio noise with the exception of natural static.

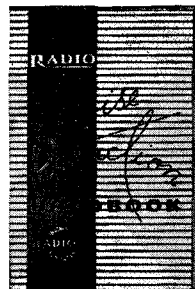

Use of the systems described will frequently mean the difference between an unintelligible signal and one which can be read with ease. Emphasis is laid on elimination of noise at its source. When this is impractical, a highly effective modification of the noise balancing method, which brings equally good results, is explained. A complete description, theoretical and constructional, of the application of this method is included.

35c in U.S.A. Elsewhere, 40c

THE EDITORS OF
RADIO
1300 Kenwood Road, Santa Barbara
CALIFORNIA

Figure 10, page 458
Field Strength Meter

Variable condenser—Hammarlund "Star"
Coil form—Bud type 906
Tube—RCA

Figure 14, page 460
Sensitive F.S. Meter

C₁—Hammarlund "Star"
C₂—Cornell Dubilier 1-W
Coil Form—Hammarlund XP-53
M—Triplett 221

Figure 17, page 462
Grid Leak F.S. Meter

C₁—Cardwell ZR-50-AS
C₂—Sprague 45-35
C₃—Sprague 1FM-35
C₄—Sprague 1FM-21
R—Centralab 516
M—Triplett 321
Cabinet—Bud 999 with chassis
Feed-Through Insulators—Johnson 44
1½-Volt A bat.—Burgess "Little Six"
45-Volt B bat.—Burgess B-30
4½-Volt bat.—Burgess 5360

Figure 22, page 464
Frequency Meter-Monitor

C₁, C₂—Hammarlund MC-150-B
CH—Thordarson T-13C26
R₁ to R₃—Centralab 710-714
C₃, C₄, C₅, C₇—Cornell Dubilier type 1W
C₆, C₈, C₉, C₁₀, C₁₁—Cornell Dubilier DT
C₁₂, C₁₃—Cornell Dubilier JRC-288
Tubes—RCA

Figure 28, page 467
C. W. Monitor

C₁, C₂—Cornell Dubilier type 1W
C₃—Hammarlund SM-50
C₄, C₅—Cornell Dubilier DT
R₁, R₂, R₃—Centralab 710
S₁—Centralab 1405
Tube—RCA
RFC—Hammarlund CHX
Dial—Bud D103B

Figure 31, page 469
Phone Test Set

S₁—Yaxley selector type
C₁—Bud type 906
Dial—Crowe type 292
Tube—RCA
M—Triplett 321

Figure 33, page 470
Keying Monitor

Speaker—Wright DeCoster N5LBU with trans.
C₁, C₂, C₃—Sprague TC
R—Centralab 710

Figure 34, page 470
Ohmmeter

Resistors—Ohmite
Meter—Triplett 221
Switch—Mallory-Yaxley 3100-J

Figure 37, page 472
R.F. and A.F. Power Meter

R—Ohmite D-100
M—Weston 425

Figure 42, page 474
Wide Range A. F. Oscillator

C₂, C₃—Solar MW-1216
C₄—Solar S-0257
C₅—Solar S-0263
C₆—Solar S-0240
C₇—Solar DT-874
C₈—Solar DAA-708
C₉, C₁₀—Solar D-820
½ and 1 Watt resistors—Centralab 710 and 714
10-watt resistors—Ohmite "Brown Devil"
S₁—Yaxley 3226J
T₁—Thordarson T-57S01
T₂—Thordarson T-13R11
CH—Thordarson T-13C28
R—GE Mazda no. S6

Figure 46, page 476
Cathode-Ray Modulation Checker

Resistors—Centralab 514-516
T—Thordarson T-92R33
C₂—General Electric Pyranol type
R₂, R₃, R₇—Yaxley universal type
C₁—Solar "Domino"
Tubes—RCA

Figure 49, page 479
902 Oscilloscope with Sweep

R₉, R₂₀—Yaxley Y50MP
R₁₀—Yaxley UC506
R₁₂—Yaxley UC504
R₂₀—Yaxley Y500MP
R₂₁—Yaxley Y25MP
R₂₀, R₃₀—Yaxley Y100MP
All tubulars—Solar "Sealdtite"
Filter condensers—Solar DE908
SW₃—Yaxley 3215J
SW₄, SW₅—Yaxley 3234J
All tubes—RCA
T₁—Thordarson T-92R33

CHAPTER 25 RADIO THERAPY

Figure 3, page 500
200-Watt Portable Diathermy

C₂, C₃—Solar type
C₄—Cardwell MT-100-GS
C₅, C₇—Solar type
C₆—Solar type
R₁—Ohmite type
RFC₁—National R-154-U
RFC₂—National R-154-U
M—Triplett type 326
T₁—Thordarson T-74F23
T₂—Thordarson T-19P58
T₃—Thordarson T-19F90
Overload relay—Guardian
75-T's—Eitel McCullough
TW-75's—Taylor
866's—General Electric

SEND POSTAGE STAMP FOR

CATALOG

BOOKS, MAGAZINES,
MAPS, BINDERS

THE EDITORS OF
RADIO 1300 Kenwood Road, Santa Barbara
CALIFORNIA

Index

A	
Absorption Wavemeter	452
A.c. Component	292
A.c. Generator	35
"Accordion Coil" R.F. Amplifier	264
Acorn Tubes—See "Receiving Tube Characteristics"	
Adjustment of Crystal Oscillators	153 to 158
Adjustment of Receivers	90, 93
Adjustment of Transmitters, Safety in	247
Aerial: See—"Antennas"	
A.f. Peak Limiters	87, 212
A.f. Power Measuring Device	471
Air Core	44
Air Gap, Filter Choke	295
Air Gap, Tuning Condenser	31, 170
Alignment, Receiver:	
I.F.	91
Multiband	92
Superheterodyne	90
Tuned R.F.	90
All-Wave Receivers, Interference in	496
Allocation of Frequencies	13
Alternating Current	35
Angular Velocity	37
Effective Value	37
Generation	35
Rectified	37
Transformers	44
Alternator	35
Aluminum Drilling	486
Aluminum Paint	489
A.M.	184
Amateur, The	7
Amateur Bands	13
Amateur Call Areas	11
Amateur Licenses	8
Amateur Operators	8
Amateur Radio, Introduction to	7
Amateur Radio Laws and Regulations—See "Radio Laws"—Appendix	
Amateur Service, Defined—See "Radio Laws"—Appendix	
Ampere, Definition	21
Amplification	56
Amplification Factor (μ)	57
Amplifier:	
"Accordion Coil"	264
Action of Vacuum Tube	56
A.f.	57, 60, 70, 271
Beam Power Tube	55
Bias	173
Class A	57
Class AB	58
Class B	58, 61, 159
Class BC	188
Class C	61, 159
Degenerative Feedback (see also—Inverse Feedback)	209
Excitation	165
Gain	208
High Powered (r.f.)	262
Hints, U.H.F.	348
I.f.	81, 91
Input	271
Inverse Feedback	210
Linear	197
Load Impedance	59, 164
Medium Powered (r.f.)	262
Microwave	391
Parallel Rod—See "U.H.F. Transmitters"	
Parallel Tube	59
Power	60, 208, 471
Push-Pull Tube	262, 509
Ratings	505
R.f.	61, 69, 159
R.f., Neutralization	160
R.f. Tank Circuit Capacities	167
Series Feed	177
Shunt Feed	61
Single-Ended r.f.	269
Specifications	509
Speech (See also—"Modulators")	207
Standard Push-Pull Circuit	262
Television Pentodes	55
Voltage	507
Amplitude	184
Amplitude Modulation	184
Systems	187
Angle of Plate Current Flow	61, 166
Angle of Radiation	394, 395
Angular Velocity	37
Antenna Couplers	416, 421, 442
Antenna Coupling	416, 421, 442
Antenna Directivity	399, 423, 443
Antenna Feeding—See "Antennas: Feed Systems"	
Antenna Impedance	397, 398, 442
Antenna Insulation	446
Antenna Length	397
Antenna Matching (see also—"Antennas: Feed Systems")	416, 421, 442
Antenna, Mobile	450
Antenna Radiation	393
Antenna, U.H.F.	447
Antenna Wire	446
Antennas	393
Angle of Radiation	394, 395
Broadside Arrays	431
Broadside Radiation	431
Characteristics and Considerations	398
Collinear	429
Compact	440
Coupler, Simple Universal	421
Coupling to Transmitter	416
Current Fed	403, 411
Delta-Matched	409
Diamond	426
Dipole	395, 428
Directional Arrays	423
Aperiodic Long Wire	424
Barrage	432
Close-Spaced—See "Kraus Flat-Top"	
Collinear	429
Diamond	426
Double Extended Zepp	430
Franklin	429
Kraus Flat-Top	438
Loop	443
Multiple-Stacked Broadside	431
Orientation of	435
Rhombic	426
Rotatable Arrays	437
Smith X-H	431
Stacked Dipole	428
Sterba Barrage	432
Unidirectional	433
V	425
W8JK Rotary Flat-Top	438
X-H Array	431
Direction Indicators	439
Directivity	399, 423, 443
"Don'ts"	420
Double Extended Zepp	430
Doublet	405
Doublet, Two Wire	410
Doublet, Multi-Wire	410
Dummy	422
Effect of Ground	400
Electrical Length	397
End Fed	400
End-Fire Directivity	432
Feed Systems:	
Close-Spaced Antenna—See "Kraus Flat Top"	
Coaxial	408
Concentric Lines	408
Considerations	405
Coupling to Transmitter	416, 421
Current	411
Delta-Matched	409
Discussion	400, 405
End	400
EO-1	409
Four-Wire	415
Impedance	405
Johnson-Q	414
Linear Transformers	407, 414
Losses in	408
Matching Non-Resonant Lines	409
Matching Stubs	411
Multi-Wire	415
Nonresonant	407
Open Lines	406
Q Antenna	414

Q-Matching Section	414	Arrays (See—"Antennas, Directional Arrays")	
Resonant	405	AT-Cut Crystals	153
Rotatable Antenna	437	Atomic Number	19
Rotating Mechanisms	439	Atomic Theory	19
Semi-Resonant	406	Atoms	19
Shorted Stub	413	Audio-Frequency Amplifiers	57, 84, 271
Single-Wire Feed	410	Distortion in	60
Spreaders	405	Audio-Frequency Impedance Matching	45
Sterba Barrage Array	432	Audio-Frequency Interstage Coupling	60
Stub Matching	411, 412	Audio-Frequency Power Measuring Device	471
Surge Impedance	407	Audio Gain Calculations	208
Transmission Lines	405	Audio Oscillator, Wide Range	473
Tuned Transmission Lines	405	Audio System, Transmitter	245
Twisted-Pair Feeders	407	Aurora Type DX	340
Universal Coupler	421	Auto Transformer	45, 46
Untuned Transmission Lines	406	Auto Transformer, r.f.	45, 46
Voltage	411	Autodyne Detector	129
Y-Matched Impedance	409	Automatic Bias	174
Field Strength Meters—See "Test and Measuring Equipment"		Automatic Gain Control	84, 93, 282
Flat-Top Beam	433	Automatic Modulation Control	212, 285, 287
Four-Wire R.F. Transformer	415	Automatic Modulation Control, Universal	287
Franklin	429	Automatic Peak Limiting	212
Fuchs	400	Automatic Volume Control	84
Fundamental Frequency	397	Automobile "Rear End," Antenna Rotating Systems	439
Ground Connection	401	Average D. C. Value	38
Ground Effect	393, 394	Average Power	186, 199
Ground Resistance	399	Axis, Crystallographic	153
Grounded Antennas—See "Marconi"			
Guy Wires	445		
Half-Frequency Operation	397, 440		
Half Wave	396		
Harmonic Operation	416		
Harmonic Resonance	397		
Harmonic Radiation Suppression	419		
Hertz	397, 403		
Horizontal Pattern vs. Vertical Angle	399, 423		
Impedance	397, 398		
Insulation	446		
Johnson Q	414		
Kraus Flat-Top Beam	433		
Length	397		
Linear r.f. Transformers	414		
Loading Coils	403		
Loading of Transmitter	416		
Long-Wire Directive Antennas	424		
Loop	443		
Marconi (Grounded) Antennas	397, 401, 402		
Masts, Fixed	445		
Masts, Rotatable	437		
Matching Non-Resonant Lines	409		
Matching Stubs	411		
Mobile U.H.F.	450		
Multiple-Stacked	431		
Multi-Wire Doublet	410		
Non-Resonant (Rhombic)	426		
Open-Ended Stubs	412		
Orientation	435		
Phased Arrays	429		
Polarization, Vertical vs. Horizontal (U.H.F.)	448		
Portable (See—"Mobile U.H.F.")	450		
Q-Matching Section	414		
Radiation	394, 395		
Radiation Characteristics	398		
Radiation, End Fire	432		
Radiation Resistance	397, 398		
Receiving	441		
Resonance	397, 398		
Rhombic	426		
Rotary (Rotatable)	436		
Shorted Stubs	411		
Single Wire Fed	410		
Smith X-H Array	431		
Stacked Dipole	428		
Standing Wave Indicator	413		
Stubs	411, 412, 413		
Support	445		
Transformers, Matching	414, 415		
Transmission Lines	403, 405		
Tuned Doublet	405		
Tuned Feeder Considerations	405		
Two Wire Doublet	410		
U.H.F.	447		
Unidirectional	433, 436		
Universal Coupler	421		
V Type	425		
Vertical	397		
Voltage-Fed	403, 411		
Wavelength	397		
W8JK Rotary Flat-Top	438		
Wire	446		
X-H Array	431		
Zepp	403		
Antilogarithm	505		
Appendix	513		
Application for Licenses	8		
Application of the Vacuum Tube	56		
Arithmetical Selectivity	72		
Armstrong System of Frequency Modulation	184		
		B	
		B5-Cut	153
		Back E.m.f.	27
		Balanced Lines (See—"Transmission Lines")	
		Balancing Coils	442
		Balancing Noise, Systems for	86
		Band-Edge Frequency Spotter	453
		Bandpass Circuits	81
		Bands, Amateur	13
		Bandset Condenser	78
		Bandspread	78
		Electrical	78
		Mechanical	78, 80
		Tapped-Coil	79
		Bandswitching	78 to 80
		Bandswitching Exciter, 100 Watt	256
		Bandswitching Test Oscillator	472
		Bandwidth, for F.M.	215
		Barkhausen-Kurtz Oscillator	152
		Barrage Array, Sterba	432
		Bass Suppression	201
		Battery Bias	174
		Battery, Dry	49
		Battery, Storage	49
		Beam Power Amplifier—See "Medium and High Power R.F. Amplifiers"	
		Beam Power Tubes	55
		Beams (See—"Antennas, Directional Arrays")	
		Beat-Frequency Oscillator	86
		Beat-Frequency Oscillator Adjustment	86, 92
		Beat-Note	68
		Bel	502
		Bending Effect	339, 393
		Bending Ends of Antenna	440
		Bias:	
		Automatic	174
		Battery	174
		Cathode	174
		Considerations	173, 302
		Cutoff	53, 58, 61
		Definition	53
		Detector	63
		Doubler	165
		For Cathode Modulation	195
		Grid Leak	173
		Separate Supply	174, 301
		Transmitter	173
		B-K Oscillator	152
		Blanketing	491
		Bleeder Resistor	23, 296
		Bleeder, Safety	247
		Blocked-Grid Keying	180
		Bombardment, Filament	50, 55
		Bonding Water Pipe Grounds	402
		Brass Drilling	486
		Breadboard Construction	482
		Breakdown, Dielectric	30
		Breakdown Potential, Mercury Vapor	63
		Breakdown Ratings of Transmitting Condensers	171
		Break-In Keying	181
		Bridge Rectifier	294, 300, 301
		Broadcast Interference	491
		Broadside Antenna Arrays (See—"Antennas, Directional")	
		Brute Force Filter	293
		Bug Key	14
		Buzzers, Code Practice	14
		Buyer's Guide	576

C

C Value for Crystal Oscillator Tanks.....	154
C Value for R.F. Amplifier Tanks.....	167
Cable, Coaxial (Concentric).....	408
Cable, EO1 Transmission.....	407
Calculations (General.).....	502
Calculations:	
Amplification Factor.....	57
Amplifier Specification.....	208
Antenna Length.....	397
Bleeder Resistor.....	23, 25
Capacitive Reactance.....	34
Capacity.....	30
Circuit Q.....	41, 77, 168
Coil.....	29, 510
Concentric (Coaxial) Line Impedance.....	408
Decibel.....	502
Delta-Matched Antenna.....	409
Effective Values.....	37
Frequency of Resonance.....	40, 397, 509
Gain Amplifier.....	504, 506
Impedance.....	40, 42, 292
Impedance Matching, Voltage & Turns Ratio.....	44
Impedance, Parallel Resonance.....	42
Impedance, Series Resonance.....	40
Inductance.....	28
Inductive Reactance.....	33
Instantaneous Voltage.....	36
Johnson Q Antenna.....	414
Logarithmic.....	502
Modulation Percentage.....	186
Modulation Transformer.....	200
Mu.....	57
Nomograph, Coil Calculator.....	510
Peak Values.....	37
Power.....	502
Power Factor.....	37, 38
Q.....	41
Q Matching Section.....	414, 415
Reactance, Capacitive.....	509, 511
Reactance, Inductive.....	33, 509, 511
Reactance and Resistance in Combination.....	34
Resistance.....	21
Resonant Frequency.....	40, 508
R.f. Tank Circuit.....	512
R. M. S. Values.....	37, 294
Series Resonant Circuit, Impedance of.....	40
Specifications, Amplifier.....	509
Surge Impedance, Concentric (Coaxial) Line.....	341 to 348
Surge Impedance, 2-Wire Transmission Lines.....	407
Transformer Design.....	305
Transmission Line.....	407, 415
Transmission Range, U.H.F.....	339
Voltage Dividers.....	25
Wattage.....	23
Wavelength-Frequency.....	397
Y-Matched Antenna.....	409
Calibration:	
Frequency Meter.....	465
Instruments.....	465
Monitor.....	465
Oscillator.....	465
Signal Generator.....	476
V. T. Voltmeter.....	463
Wavemeter.....	453
Call Areas, Amateur.....	11
Call Letters, Amateur Radio Station.....	9
Capability, Modulation.....	186, 201
Capacitance, Vacuum Tube.....	54, 80
Capacities:	
Circuit.....	80
Inter-electrode.....	54
Capacitive Coupling.....	175
Capacitive Reactance.....	34, 67
Comparison to Inductive Reactance.....	34
Capacity:	
Calculation of.....	30
Circuit.....	80
Coupling—"Interference".....	493
Definition.....	29
Distributed.....	397
Formulas.....	30, 31
Switching.....	80
Tank Circuit.....	167
Unit of.....	29
Carbon Microphone.....	205
Carrier.....	184
Carrier Power.....	186
Carrier Shift.....	186
Cathode.....	50
Cathode Bias.....	174, 305
Cathode, Heater Type.....	50, 52
Cathode Impedance.....	194
Cathode Modulated Transmitter.....	322
Cathode Modulation.....	192
Cathode Modulator.....	194
Cathode Ray Oscilloscope.....	476

Cathode Ray Tubes (Characteristics).....	128
Cathode Regeneration.....	165
Cavity Resonance.....	341, 349
Cell, Dry.....	49
Cell, Edison.....	49
Cell, Lead.....	49
Cell, Primary.....	49
Cell, Secondary.....	49
Center-Tap Keying.....	182
Centimeter Waves and Microwaves.....	349
Characteristic Impedance, Feeder.....	405
Characteristic, of Logarithm.....	502
Characteristics and Considerations of Antennas.....	398
Characteristics of Vacuum Tubes:	
Discussion.....	52
Receiving.....	96
Rectifiers—See "Transmitting" or "Receiving Tubes".....	
Transmitting.....	224
Voltage Regulators—See "Receiving Tubes".....	
Charts:	
Amateur Abbreviations—See "Appendix".....	
Amateur Wavelength-Frequency Bands.....	13
Antenna Coupling to Transmitter.....	400
Antenna and Feeder Lengths.....	413
Antenna Feeding Methods.....	400
Antenna Transformer.....	407
Antenna Field Patterns.....	423
Cathode Modulation Operation.....	193
Choke Design (Filter).....	311
Circular Plate Condensers.....	31
Coaxial Lines (See also: "Concentric Lines").....	408
Coil Inductance, Nomograph.....	510
Coil Tables (These are included in all Constructional Chapters).....	
Collinear Antenna Design.....	430
Concentric Line Impedance.....	408
Concentric Line Resonance.....	342
Condenser Air Gap.....	171
Condenser Breakdown Voltage.....	171
Condenser Microphone.....	205
Continental Code.....	12
Copper Wire Tables.....	306, 308
Coupling into Transmission Lines.....	343
Coupling Transmission Lines to Antennas.....	418
Db Power Levels.....	506
Db-Power Ratios.....	504
Detector Circuits.....	68
Diamond (Rhombic) Antenna Design.....	427
Dielectric Constants.....	30
Drill Sizes.....	487
Filter Choke Design.....	311
Flat-Top Antenna Design.....	434
Four-Wire Matching Section.....	415
Franklin Antenna.....	430
Frequency Meter Curve.....	465
Horizontal Doublet, Vertical Directivity.....	399
Inductance.....	510
Johnson Q.....	414
L-C Data.....	169
Logarithms.....	503
Long-Antenna Design.....	424
Matching Section Surge Impedance.....	407
Matching Stub Applications.....	411
Mixer-Oscillator Combinations.....	73
Modulated Class C Input Values.....	201
Modulator Data.....	201
Oscilloscope Patterns.....	477
Q-Antenna Dimensions.....	414
Q-Bar Dimensions.....	414
Q Signals—See "Appendix".....	
Radiation Resistance.....	398
Radio Symbols—See "Appendix".....	
Reactance, Frequency Chart.....	508, 511
Receiving Tubes.....	95
Rectifier-Filter Chart.....	300, 301
R.F. Feeder Losses.....	408
Rhombic Antenna Design Charts.....	427
R-S-T Reporting System—See "Appendix".....	
Selectivity.....	41
Series Circuit Reactance-Frequency Variation.....	39
Socket Connections.....	116, 225
Stacked Dipole Design.....	432
Stub Length.....	411
Surge Impedance:	
Coaxial Line.....	408
Multiconductor Transmission or Matching Transformer.....	415
Open Line.....	407
Q Section.....	414
Tank Circuit Voltage.....	171
Tools.....	483
Transformer Design.....	308
Transformers, Antenna.....	414, 415
Tube Tables:	
Receiver Types.....	95
Rectifier Types (See "Transmitting" or "Receiving" Tube Tables).....	
Transmitting Types.....	224

U. S. Call Areas	11
U. S. Radio Districts	11
V-Antenna Design	426
Vacuum Tube Characteristics, Receiving	95
Vacuum Tube Characteristics, Transmitting	224
Vertical Directivity, Horizontal Doublet	399
Wire Tables	306, 308
Chassis Building:	
Assembly	482
Dish Type	283
Layout	487
Metal	487
Plating and Painting	489
Punching	488
Choke Air Gap	295
Choke Coil	292
Choke Considerations	295
Choke, Core Material	29, 295
Choke Design	28, 312
Choke, Filter	295
Choke Input	292, 293
Choke, R.f.	177
Choke, Smoothing	295, 312
Choke, Swinging	295, 312
Chokes, Types of	295
Chromium Polish	490
Circuit:	
A.V.C.	84
A.M.C.	285, 287
Analysis: (See Particular Circuit Under "Theory")	
Bridge Rectifier	299
Capacities	80, 83, 167
Coupling	46, 47, 60
Feedback (Modulator)	278
Filter	82, 83
Flywheel Effect in	43
F.M. Modulator	215
Impedance of	35, 42, 46
Neutralizing	160
Noise Balancing	86
Noise Limiting	87
Parallel Tube	177
Phase Inverter	275
Push-Pull Audio	59, 60, 200, 273
Push-Pull r.f.	178, 262
Q	41, 242
Reactance-Resistance Modulator	216
Rectifier	295, 298, 299, 300, 301
Relation to Tank Current (Parallel Resonance)	42
Resonant	40
Series	39
Circuits:	
Bandpass	81
Bandspread	79
Crystal Filter	82
Doubler	165
Neutralizing	161, 162, 163
Oscillator-Doubler	159
Receiving (See—"Receivers")	
Rectifier	299
Regenerative Detector	68
Regenerative Doubler	165
Series Filament	26
Single-Frequency	77
Transmitting (See—"Transmitters")	
Tuned	39, 41
Voltage Regulating	298
Circular Mills	306
Circulating Tank Current	42
C-L Ratios	41, 167
Class A Amplifier	57
Class A Modulator	209
Class AB Amplifier	58, 209
Class AB Modulator	209
Class B Amplifier	58, 61, 159, 197
Class B Bias	58, 61
Class B Modulator	209
Class B Modulator Voltage Regulation	290
Class BC Amplifier	188
Class C Amplifier	61, 159
Class C Bias	61, 173
Class C Grid Modulation	189
Clickless Keying Methods	178
Clicks, Key	178
Close-Spaced Directional Array	438
Coaxial Line	341 to 348, 408
Code:	
Buzzer	14
Classes	18
Continental	11
Correct Position for Sending	12
Learning the	12
Monitor	469
Practice Oscillator	14, 469
Coefficient of Coupling	28
Coil, Balancing	442
Coil, Loading	403, 440
Coil, Placement of	242

Coll Tables (These accompany each of the Constructional Chapters)	
Coil Winding, Transformer	308
Coil Windings	44, 510
Collinear Antenna	429
Collinear Antenna Design Chart	430
Collins Antenna Coupler	416
Combination of Reactance and Resistance	34
Communication, U.H.F.	339
Communications Law, Amateur—See "Radio Laws"—Appendix	
Compact Antennas	440
Comparative Feeder Losses	408
Complex Waves	185
Component, A. C.	292
Components, Basic Receiver—See "Radio Receiver Theory"	
Components, Mounting	489
Concentric Lines—(See also—"Coaxial Lines")	341
Concentric-Line Oscillators	347
Condenser:	
Air Gap	30, 31, 170
Bandset	78
Breakdown Rating	30, 32
Capacitance	29, 30
Definition	29
Discharge	30
Dry Electrolytic	295
Electrolytic	295
Energy Stored in	29
Filter	295
Ganged Tuning	69
Input (Rectifier)	293
Microphone	206
Oil Filled	295
Padder—(See also—"Trimmer Condenser")	93
Paper Dielectric	295
Parallel Connection	31, 32
Plug-In	242
Rating (Series Connection)	32
Reactance	34
Series Connection	31, 32
Series-Parallel Connection	31, 32
Switching	80
Tank Circuit	167
Tracking	78, 93
Trimmer	93
Tuning	67, 170
Variable, Transmitter	170, 242
Wet Electrolytic	32
Condensers in A. C. Circuits	32, 34
Condensers in D. C. Circuits	31, 34
Conductance, Conversion	65
Conductance, Mutual	57
Conduction of Electric Current	20, 48
Conduction, Electrolytic	48
Conduction, Gaseous	48
Conduction by Ions	48
Conductivity	20, 48
Conductors	20, 48
Connections, Electrolytic Condensers	32
Connections, Tube Socket:	
Receiving Tubes	116
Transmitting Tubes	225
Constant Efficiency Modulation	187
Construction:	
Breadboard	482
Transmitter	313, 482
Dish Type	483
Metal Chassis	482
Practice	487
Push-Pull Amplifier	262, 267
Radio Receiver	129
Radio Therapy (Diathermy) Machine	498
Radiophone Transmitter	313-338
Relay Rack Type	483
R. F. Amplifier	262-270
Tools	482
Transmitter	313
Two-Wire Transmission Lines	407
Continental Code	12
Control, Automatic Modulation	212, 274, 286
Control Grid	53
Control Grid Injection	74
Controlled Regeneration	76
Conversion Conductance	65
Conversion, Decibels to Power	505
Conversion, Doublet	76
Conversion Efficiency	72
Conversion, Frequency to Wavelength	396
Converter:	
Circuits	75, 350
Dual Unit	74
Frequency	65, 72
High Frequency	850
Pentagrid	55, 74
Tubes	74
U. H. F.	850
Copper Tubing, Antenna Element	436, 446

Copper-clad Wire	446
Copper Wire Tables	306, 308
Core, Air	29, 44
Core Losses	29, 307
Core Material	29, 44
Core, Powdered Iron	29, 81
Core Saturation	27, 307
Core Size	29, 305
Cottrell Process	48
Coulomb, Definition	21
Counter E. M. F.	27
Counterpoise	402
Coupler, Antenna	442
Coupler, Pi-Section (Collins)	416
Coupling:	
Antenna to Receiver	441
Antenna to Transmitter	164
Capacitive	175
Coefficient of	28
Devices	46, 47, 175, 441
Effect of Impedance on	43
Impedance	43, 46, 60
Inductive	28, 46, 67, 175
Input	441
Interstage	46, 47, 60, 81, 175
Link	47, 176
Loops	176
Methods	46, 47, 176, 343, 441
Resistance	60
R.F. (See listings under "Capacitive, Inductive," etc.)	
Taps	45, 47
Transformer	45, 60
Unity	47
Coupling Transformer for Grid Modulation	190
Cross Index to Transmitting Tubes	224
Crystal:	
Action in I.F. Amplifier	82, 91
AT-Cut	153
Axes	153
B5-Cut	153
Calibrator	456
Current	153 to 158
Dual Frequency	456
Filters	82
HF-2 Cut	153
High Frequency	154
LD2	153
Low Drift	153
Mechanical Activity of	153
Microphone	206
Mounting	154
Oscillators	153, 155 to 158
Parasitics in	172
Power Limitations	153, 154
Special Cuts	153
Temperature Effects	153
Theory of	153
Tourmaline	153
Twin Peaks	153
Use and Care of	154
V-Cut	153
X-Cut	153
Y-Cut	153
Crystal Axes	153
Crystal Calibrator, Dual Frequency	456
Crystal-Controlled 5-Meter Transmitters—See "U.H.F. Transmitters"	
Crystal Current	153 to 158
Crystal Cuts	153
Crystal Filter	82
Crystal Filter Alignment	82, 91
Crystal Holders	153
Crystal Microphone	206
Crystal Oscillator Tuning Procedure	153, 154, 158
Crystal Oscillators	153 to 158
Current:	
Alternating	33
Conduction	20, 48
Crystal	153 to 158
Direct	20, 48
Electric	20, 48
Feed for Antenna	403, 411
Flow	20, 21, 48
Flow in Bias Supply	301, 302
In A.c. Circuits	37, 38
In Voltage Divider	24
Lag	38
Lead	38
Load, Peak	294
Loops	395
Magnetic	27
Nodes	395
Peak	38
Cutoff Bias	53, 58, 61, 174
Cutoff Frequency	292
Cutouts, Chassis	488
Cuts, Crystal	153
Cutting Sheet Metal	487

C.w. Keying	178-183
C.w. Monitor	463, 466
C.w. Transmitter (See—"Transmitters")	
Cycle	33

D

Damping Action	70
Db Units	502
D.c. Working Voltage, Definition	30
Decibel Calculations, Speech Amplifier	502
Decibel-Power Chart	504, 506
Decibels to Power	504, 506
Decibels, Voltage Ratio	507
Degeneration	209
Degenerative Feedback Amplifier	210
Degree, Electrical	36
Delta-Matched Impedance Antenna	409
DeLuxe Cathode Ray Oscilloscope	476
Demodulation	63, 66
Density, Flux	27
Design:	
Bleeder-Resistor	23
Cathode Modulation	192
Collinear Antenna	430
Diathermy Machine	498
Direction Indicator, Rotary Antenna	439
Filter Choke	312
Filter Circuits	82, 83
Flat-Top Beam	434
Four-Wire Matching Section	415
Johnson Q Antenna	414
Keying Systems	178-183
Long-Wire Antenna	424
Mobile-U.H.F. Antennas	450
Modulator	271-290
Power Supplies	291-312
Power Supplies for Radiotelephony	289
Push-Pull R.F. Amplifier	171, 262
Q-Matching Section	414
Rectifier Circuits	295, 298, 299, 300, 301
Rhombic Antenna	427
Rotary Antenna	436
Rotating Systems for Antennas	439
Series Filament Circuits	26
Speech Equipment	271-290
Stacked Dipole	428, 432
Tank Circuit	167
Transformer	305
Transmitter	240
Universal Antenna Coupler	421
V Beam Antenna	426
Voltage Dividers	24
Voltage Regulators	290, 297
Design Considerations, F.M. Receiver	223
Design Considerations, Transmitter	240, 242
Detection	63, 66, 84
Detector Circuits (Regenerative)	67, 68
Detector-Oscillator Alignment	93
Detector, Frequency	221
Detectors (Discussion of types)	63
Definitions, F.C.C.—See "Radio Laws"—Appendix	
Deviation	215
Deviation, Measurement	218
Deviation Ratio	215
Diamond Antenna (Rhombic)	426
Diaphragm, Microphone	206
Diathermy	498
Dielectric	29
Dielectric Breakdown	30
Dielectric Constant (and values)	30
Dielectric Stress	30
Dielectric Thickness	30
Difference of Potential	21
Dimensions, Delta-Matched Antenna	409
Dimensions, Marconi	402
Diode	50, 52
Diode Bend	53
Diode Detector	64, 67
Diode Feedback Rectifier	212
Diode-Type F.S. Meter	457
Diode V.T. Voltmeter	462
Dipole	393
Dipole Antenna, Stacked	428
Direct Current	20, 48
Direct Current, Pulsating	62
Direction of Current Flow	20, 21, 40
Direction Indicator, Rotatable Antenna	439
Directional Effects of Crystal Microphone	207
Direction Finders	443, 451
Directive Antennas	423
Directive Properties of Antennas	399, 423
Dish-Type Constructions	483
Discharge, Condenser	29
Discharge, Glow	297
Discriminator, Travis	221
Discriminator, Foster-Seeley	222
Dissipation, Plate	60, 224
Distortion	60

Distributed Capacity	80, 397
Distributed Inductance	397
Distributed Resistance	397
Dividers, Voltage	24
Doherty, Linear Amplifier	198, 203
Double-Button Microphone	205
Double Conversion	76
Double Extended Zepp	430
Doublers:	
Angle of Plate Current Flow in	165
Bias	165
Conventional	165
Frequency	165
Push-Push	167
Regenerative	165
Tube Requirements	165
Doublet Antenna	405, 410, 440
Drift, Frequency	152, 154
Drill Sizes	487
Drilling	485
Drilling Glass	490
Driving Mechanism, Antenna Rotating	439
Driving Power, R.F. Grid	241
Drop, Voltage	21, 24
Dropping Resistor	24
Dry Cell	49
Dry Electrolytic Condensers	295, 296
Dual Frequency Crystal Calibrator	456
Dual Rotor Bandsread	79
Dual Tubes	56
Dummy Antennas	422
Duralumin Diaphragm	206
DX, Aurora Type	340
Dynamic Characteristic	59
Dynamic Microphone	207
Dynatron	152

E

E.c.o. Harmonics in Superheterodyne	74
Eddy Current Losses	29, 305
Edison Cell	49
Edison Effect	50
Effect of L/C Ratio, Parallel Circuits	42
Effect of Coupling upon Impedance	43
Effect of Coupling upon Resonance	47
Effect of Loading upon Q	168
Effect, Piezoelectric	153
Effective Resistance	22
Effective Value of Voltage	37, 38
Efficiency, Amplifier	58, 159
Efficiency Modulation	187
Efficiency, Plate	159
Efficiency, Rectifier	63, 64
Electric Charge	29
Electric Current, the	20
Electric Field	27
Electric Power	23
Electrical Bandsread	78
Electrical Length	397
Electrical Storage of Energy	29
Electrical Units	21
Electricity	20
Electrolyte	49, 296
Electrolytic Condensers	32, 295
Electrolytic Conduction	48
Electromagnetism	27
Electromagnetic Component	393
Electromagnetic Effects	27
Electromagnetic Radiation	393, 395
Electromagnetic Waves	393
Electromotive Force (E.M.F.)	21
Electron	19, 48
Electron Flow	20, 48
Electron, Free	19, 48
Electron Orbit Oscillator	389
Electron Ray Tube	85
Electronic Conduction	20, 48
Electronic Emission	50
Electronic Saturation	52
Electrostatic Component	393
Electrostatic Coupling	420
Electrostatic Energy	29
Electrostatic Shield	47, 420, 442
Elements, Rotatable Antenna	436
Elimination of Harmonics	419
Elimination of Interference	72, 75, 178, 491-497
E.M.F. (Back) Counter	28
E.M.F., Unit of	21
Emission, Electronic	50
Emission, Secondary	55
Emitters, Types of	50
End-Fed Antennas	400
End-Fire Directivity	432
Energy Stored in Condensers	29
Energy Stored Electrostatically	29
Energy Stored in Magnetic Field	21
EO1 Cable	407
Equipment Considerations	341

Equivalent Circuit, Crystal Filter	82
Etching Solution	490
Evolution of a Zepp Antenna	404
Examination, Amateur Licenses	526
Excitation, Grid	165
Excitation Keying	178
Exciter Design	240
Exciters and Low Powered Transmitters	249-261
Exciters (See also—"Oscillators and Crystal Oscillators")	
Multiband Frequency Multiplier	255
Multiband 100 Watt	256
Simple 15-Watt Two Band	249
Ten-Watt V.F.O.	252
Exponent, Decibel Calculations	502
Exposed Components and Wires in Transmitters	246
External Load	292
Extended Positive Peak Modulation	187
Factor, Amplification (μ)	57

F

Factor of Merit (Q)	41, 77, 168
Factor, Power	38
Fading	394
Fading, Selective	394
Farad, Definition	(29), 30
Faraday Screen (Shield)	47, 420, 442
Federal Communications Commission (F.C.C.)	8
Federal Communications Commission Regulations	See "Radio Laws"—Appendix
Feed:	
Current	403
Series	177
Shunt (Parallel)	177
Voltage	403
Feedback Circuit (Modulator)	196, 209, 212
Feedback, Degenerative	196, 209
Feedback Rectifier, Diode	212
Feedback, Inverse	210
Feeder Losses	408
Feeders, Antenna (See also—"Antennas")	
for Rotary Antennas	437
Johnson Q	414
Single-Wire	410
Tuned (Zepp)	403, 405
Untuned	406
Feeding the Antenna	400, 437
Fever, Induced by Diathermy	498
Field, Electric	27
Field Strength Meter	457, 459, 460
Filament	50
Filament, Reactivation	51
Filaments in Series and Parallel	26
Files	485
Filter	291
Bardpass	81
Brute Force	293
Choke Considerations	312
Choke-Input	292, 293
Chokes	295, 312
Circuit Considerations	294
Circuits	292 to 295
Condensers (Discussion)	295
Crystal	82
Double Section	293
Key-Click	178
Line	86
Low Pass	292, 497
Noise	86, 87
Pi-Section	293
R-C	84
R.F. Filters	86
Resonance in	293
Resonant	292, 293
Single Section	292, 293
Two Section	293
Variable Selectivity	82
Final Amplifier (See also—"Transmitter Construction")	262
First Detector	65, 57
Five Meters (See—"U.H.F.")	339-367
Flat-Top Beams	433
Flat-Top Length, Zepp Antenna	404
Flexible Transmission Line	407
Flicker Effect (Shot Effect)	75
Floating Volume Control	494
Flow, Current	20, 27
Flux	27
Flux Density	27
Flux, Magnetic	27
Flux, Soldering	489
Flywheel Effect	42, 43
F.M.	184, 214
Foreword	6
Formulas (See—"Calculations")	
Foster-Seely Discriminator	222
Four-Wire Q Sections	415
Frame, Lecher	345

Franklin Antenna	430
Franklin Oscillator	153
Frequencies, Amateur	13
Frequency	33, 35
Antenna	397
Bands, Amateur	13
Calibrator	456
Conversion (in Mixers)	72
Conversion (to Wavelength)	396
Converters	65
Cutoff	292
Detector	221
Determination	40, 452, 463
Doublers	165
Drift	152, 154
Formula	40
Fundamental	40
Interruption	70
Measurement, U.H.F.	344
Mixers	65, 72
Modulation	184, 214
Multipliers	165, 255
Radio	33
Rejection	76
Relation to Wavelength	397
Resonance, Antenna	397
Resonance, of Coil (Inductance)	40, 508
Resonance (Formula)	40
Resonant Line	405
Spotting	453
Stability	72, 151, 162, 153
U.H.F.	339
Frequency Converter (Mixer)	72
Frequency Doubler	221
Frequency Doublers	165, 255
Frequency, Interruption	70
Frequency Measurement:	
100-Kc. Oscillator	456
Absorption Frequency Meters	452
Band-Edge Spotter	453
Checking Transmitter Frequency	452-457, 463
Frequency-Calibrated Signal Generator	472
Frequency Meter Calibration	453, 465
Heterodyne Frequency Meters	463
Lecher Frame	345
Lecher Wires	344
Meters (Monitors)	463
U.H.F.	344
Frequency Modulation	184, 214
Frequency Modulation Receiver	220
Frequency Modulation Transmitters	380 to 388
75 Watt 112 Mc.	381
50 Watt 112 Mc.	386
Frequency Multipliers	165, 255
Frequency-Wavelength Conversion	397
Front-End Alignment	92
Fuchs Antenna	400
Full-Wave, Radiation	397
Full-Wave Rectification	62, 291
Full-Wave Rectifier	291, 300
Full-Wave Three-Phase Rectifier	300
Fundamental Frequency	40
Fuse	304

G

Gain:	
A. F. Calculation	208, 505
Decibels	505
Effect of L/C Ratio (Parallel Circuits)	42
R.F.	61, 69
Ganged Condensers	69, 79
Gas-Filled Transmission Lines	408
Gaseous Conduction	48
Gasoline-Gauge Direction Indicator	439
Gears, Rotating Antenna Mechanism	439
General Rules, Amateur Service (See "Radio Laws"—Appendix)	
Generator:	
A.C.	35
Signal	472
Gilbert	27
Gill-Morrell Oscillator	152
Glass Drilling	490
Glow-Discharge Voltage Regulators	297
Government (See—"Federal Communications Commission")	
Great Circle Direction	399
Grid	50, 53
Grid Bias	53, 173, 190
Grid Bias Modulation	187
Grid Bias Pack Considerations	302
Grid Controlled Rectifiers	179
Grid Detection	63
Grid Excitation	165
Grid, Injection	56
Grid Keying	180
Grid Leak	68, 187
Grid Leak Bias	173

Grid Leak F. S. Meter	460
Grid Leak Modulation	187
Grid Loading Effect	78
Grid Modulated Amplifier	187
Grid Modulation	187
Grid Modulation Coupling Transformers	190
Grid Modulation, Tubes for	190
Grid Neutralization	54, 160
Grid Saturation	165
Ground Connection, Importance	401, 402
Ground, Radial Type	402
Ground Resistance	399
Ground Wave	339, 393
Grounded Antennas (Marconi)	402
Grounds	246, 400, 402
Guy Wires	445

H

H (Lazy) Antenna	431
Half-Frequency Antenna Operation	440
Half-Wave Radiators	440
Half-Wave Rectification	62, 291
Half-Wave Rectifiers	291
Half-Wave Three-Phase Rectifier	299
Hard Drawn Copper Wire	446
Harmonic Amplifier	165, 454
Harmonic Content	60
Harmonic Distortion	60
Harmonic Elimination	419, 421
Harmonic Frequency Determination	344
Harmonic Generation	165, 454
Harmonic Operation of Antennas	416
Harmonic Oscillator, Crystal	157, 159
Harmonic Radiation vs. Q.	168
Harmonic Resonance	397
Harmonic Suppression	419
Harmonic Tolerance	60
Hartley Oscillator	150
Heater Cathode	50, 52
Heating Pads, Diathermy	501
Heising Modulation	198
Henry, The	28
Heptode Tube	56
Hertz Antenna	397
Heterodyne Reception	68
HF2-Cut Crystal	153
High-Frequency Converters	350
High-Frequency Crystals	154
High-Gain Preselector	147
High-Mu Tubes (Receiving Type)	56
High Powered Amplifiers	292, 270
High Vacuum Rectifier	294
High Voltage Filter Condensers	295
High Voltage, Safety Precautions	246
Hints, Tool	484
HOLDERS, Crystal	154
Horizontal Directivity	399, 423
Horizontal Pattern vs. Vertical Angle	423
Horizontal Polarization	393
Horizontal vs. Vertical Antennas	399
Hum Difficulties	271
Hysteresis	305

I

I.f. Amplifier	81
I.f. Amplifier Alignment	91
I.f. Amplifier Noise Silencers	89
I.f. Transformer	81
Image	72, 75, 496
Image Interference	75, 496
Image Ratio	76
Impedance	77
Antenna	397
Calculation	35, 42, 407, 408
Calculation of Parallel	42
Calculation of Series	35
Cathode	194
Characteristic Surge	405
Coupling	60
Definition	20
Effect of L/C Ratio upon	42
Feeder (See also—"Transmission Lines")	405
Four-Wire R.F. Transformer	415
Johnson Q Matching Section	414
Load	45, 59
Matching (A. F. Circuits)	45, 59
Matching (R. F. Circuits) (See also—"Antennas")	46, 403
Matching, Voltage & Turns Ratio	43, 46
Parallel Resonance	42
Receiver Input Matching	77, 442
Reflected	45
Series Resonance	40
Single-Wire Feeder	410
Surge	405
Tank Circuit	42
Transformer Coupling Method	60

Transmission Line	407
Tube Plate Circuit	42
Index to Transmitting Tubes	224
Indicator, Antenna Direction	439, 444
Indicator, Field Strength	457-460
Indicator, Modulation	467, 476
Indicator, Neutralizing	468
Indicator, Signal Strength (Resonance)	85, 457-460
Indicator, Tuning	85, 467
Indirectly Heated Cathode	52
Induced Current, Losses from	305
Induced Voltage	28, 43
Inductance:	
Calculation	28
Definition	27
Frequency of Resonance	40, 508
Mutual	28
Parallel Connection	28
Self	28
Series Connection	28
Series Loading	28
Tapped	45, 46, 172
Unit of	28
Inductive Coupling	28, 46, 67, 175
Inductive Output Amplifier	349
Inductive Reactance	33
Comparison to Capacitive Reactance	34
Infinite-Impedance Detector	64
Injection	56, 72
Injector Grid	56, 74
Input Capacity	83
Input Choke	292, 293
Input Condenser	293
Input Coupling Circuit, Receiver	447
Input Impedance, Receiver	442
Input Level	207
Input Power Control	303
Input Resistance	77
Input Voltages	509
Instantaneous Voltage, Generator	36
Instantaneous Power Output	186
Instruments:	
Wavemeters (See also—"Frequency Meters")	
Audio Oscillator	473
Calibration Oscillator	453, 456, 472
Cathode-Ray Oscilloscopes	476, 479
Field Strength Meters	457-460
Frequency Meters	452, 453, 463
Generator Signal	472
Measuring	452-481
Modulation Meter	467
Monitor	463, 466, 469
Neutralizing Indicator	468
Ohmmeters	471
Receiver Testing	90, 472-478
Standing Wave Detector	413
Test Oscillator	472
Vacuum Tube Voltmeters	459
Voltmeters	462, 470
Wavemeters (See also—"Frequency Meters")	
452, 453, 463	
Insulation, Antenna	446
Insulation, Transformer	311
Insulation, Transmitter	242
Insulators	20, 242
Interelectrode Capacitance	54
Interference Classifications	491
Interference, Diathermy	501
Interference Elimination	72, 75, 178, 491-497
Blanketing	491
Diathermy	501
Electrical Noise	86-89, 491
Image	75
Key Clicks (See also—"Keying")	178
Radiotelephone Interference	492
R.F. Filters	86
Superheterodyne Harmonics	75
Thermal (In Vacuum Tubes)	75
Wavetraps	492
Intermediate Frequency	72
Intermediate Frequency Amplifiers	81, 91
Internal Noise	75
Interruption Frequency	70
Interstage Coupling	28, 46, 47, 60, 175
Introduction to Amateur Radio	7
Inverse Feedback (A.F.)	210
Inverse Feedback (R.F.)	211
Inverse Peak Voltage	294
Inversion, Temperature	339
Inverter, Phase	274
Ionization	48
Ionosphere	393
Iron Core	29, 44, 305
Iron Core I.F. Transformer	29, 81

J

Jacks, Meter	244
Johnson Q Antennas	414

K

Key Clicks	178
Key, Semi-Automatic (Bug)	14
Key, Use of	17
Keying:	
Blocked Grid	180
Break-in	181
Cathode	181
Center Tap	182
Click Elimination	178
Click Filters	178
Design Considerations	178
Excitation	178
Grid	180
Keying Tubes	182
Lag	178
Manipulation of Hand Key	11, 17
Methods:	
Center Tap	182
Controlled Rectifier Keying	179
Excitation	178
Grid	180
Plate	179
Primary	178
Monitor	469
Oscillator	181
Parasitic Clicks	179, 182
Primary	178
Transmitter	178
Tails	179
Vacuum Tube	182
Keying Interference Elimination	178
Kilocycle	33
Kozanowski Oscillator	152
Kraus Flat-Top Beam	433

L

Lag, Current	38
Lag, Keying	178
Law, Ohm's	21
Laws, U. S. Radio (Amateur Service)	513
Layer Height (Ionosphere)	393
Layouts, Chassis	487
Lazy H Antenna	431
L-C Circuits	41, 167
L/C Ratio	42, 167
LD2-Cut Crystals	153
Lead Cell	49
Lead and Lag	38
Learning the Code	12
Lecher Frame	345
Lecher Wires	344
Lecher Wire Antenna Transformer	411
Length, Antenna	397
Level, Power	504
License, Amateur	8
License, Examination for	8
License Requirements	8
Lightning	48
Limiter, Automatic Peak	87
Limiter, F. M.	222
Limiting (Noise) Circuits	86-89
Line, Transmission	341, 403
Linear Amplifier	61, 159, 197, 380, 381
Linear Amplifier, Doherty	198, 203
Linear Tank Circuits	159, 197
Linear Transformers (Antenna)	414
Linearity of Class C Amplifiers	61
Lines of Force, Magnetic	27
Link Coupling	47, 176
Load Impedance (Resistance)	43, 59
Loading Coil	403, 440
Loading, Transmitter	164
Logarithms	502
Long Skip	340, 394
Long-Wire Radiators	424
Loop Antenna	443
Loop, Current	395
Loops, Coupling	47, 176
Loops, Voltage	395
Losses, Core	29, 305
Losses, Eddy Current	29, 305
Losses, Feeder	408
Losses, Hysteresis	305
Low-Frequency Parasitics	172
Low-Pass Filter	292, 497
Low-Power Transmitters and Exciters	249

M

Magnetic Current	27
Magnetic Fields	27, 35
Magnetic Flux	27
Magnetic Line of Force	27
Magnetic Voltage	27

Magnetism	27
Magnetomotive Force	37
Magnetron Oscillator	389
Mains Supply	245
Mantissa	502
Map of U. S. Call Areas	11
Marconi Antenna	401
Masts, Rotatable	See "Rotatable Antennas"
Matched Impedance Lines	403
Matched Impedance (A. F. Circuits)	45
Matched Impedance (R.F. Circuits) (See also—"Antennas")	46, 403
Matching Impedance, Voltage & Turns Ratio	43
Matching Section, Q	414
Matching Stubs	411
Material, Core	29
Mathematics and Calculations, Radio	502
Measurements:	
A. F. Power	471
Deviation	218
R. F. Power	471
Ripple Voltage (Filter)	293
Wavelength	344
Measuring Equipment	452
Mechanical Bandspread	78, 80
Mechanics of Modulation	185
Medium and High Powered Amplifiers	262-270
Megacycle	33
Megohm	21
Memorizing the Code	12
Mercury Vapor Rectifier	301
Metal Chassis	482
Metal Saws	485
Meter, Field Strength	457, 459, 460
Meter Jacks	244
Meter Switching	243
Metering, Transmitter Circuit	243
Meters (See—"Instruments")	
Microfarad	30
Microhenry	28
Micromicrofarad	30
Microphones	204
Carbon	205
Condenser	206
Crystal	206
Decibel Rating	(See particular type.)
Directional Effects	207
Double Button	205
Dynamic	207
Loudspeaker	207
Single Button	205
Velocity (Ribbon)	206
Microwave Amplifiers	391
Microwave Antennas	451
Microwave Equipment	388
Microwave Transmitters	388
Microwaves	349, 388
Millihenry	28
Mixer	65
Mixer Noise	75
Mixer-Oscillator Circuits	73
Mixer Stage, Superheterodyne	72
Mixer Tube	55, 56
Mobile Communication	339-349
Mobile U.H.F. Antennas	450
Mobile U.H.F. Receivers	See "U.H.F."
Mobile U.H.F. Transmitters	See "U.H.F."
Modulation:	
Amplitude	184
Automatic Control	212, 274, 286
Bass Suppression in	201
Calculations	200
Capability	186, 201
Cathode	192
Checker	476
Circuits for F.M.	215
Class A	209
Class AB	209
Class B	199, 209
Class B Linear	197
Constant Efficiency	187
Control, Automatic	212, 274, 286
Cross	492
Diode Feedback Rectifier	212
Doherty	190, 203
Efficiency (Variable)	187
Equipment	271-290
Extended Positive Peak	187
Feedback Circuit	196, 209, 212
Feedback, Degenerative	209
Frequency (Armstrong)	184, 214
Grid	188, 189
Grid Leak	187
Helsing	198
Indicator	467
Mechanics	185
Meter	467
Methods	184
Monitor	467
Peaks	185
Percentage	186
Phase Inverter Circuit	274
Plate	198
Plate-and-Screen	201
Power	198
Ratings (See also "Modulators")	201
Screen Grid	191
Series	203
Sidebands	185, 288
Sine Wave	185
Splatter Suppressor	288
Suppressor Grid	191
Systems of Amplitude	187
Terman-Woodward	198, 203
Transformers	200
Tubes	190, 201
Modulators	209
Cathode	194
Classes	209
Class B 809's	279
Class B 811's	317
Class B 2A3's	279
Class B TZ-40's	281
Class B 203Z's	284
Class B T-21's	274
Feedback Circuit	210, 274
Frequency	215
Inexpensive 25 Watt	272
Mechanical	215
Phase Inverter	274
Power Supply Design	290, 299
Reactance-Resistance	216
Reactance-Tube	216
Simplified Automatic Modulation Control	212, 285, 287
Transmission Line	218
Voltage Regulation for Class B	290
6.5 Watt for Grid Modulation	277
60 Watt T-21, with A.M.C.	274
2A3 Amplifier-Driver	279
203Z for 800 Watt Transmitter	284
TZ40, for 600 Watt Transmitter	281
See also "Transmitter Construction"	
Molecule	19
Monitor	463, 466
M.O.P.A. Transmitters, U.H.F.	368
Motors, Antenna Rotating	439
Mounting Components	489
Movement, Electronic	50
Mu (Amplification Factor)	57
Multi-Band Antenna	416
Multi-Band Exciters	249
Multi-Band Frequency Multiplier	255
Multiple-Stacked Broadside Arrays	431
Multipliers, Frequency	165
Multi-Range Volt-Ohmmeter	470
Multi-Tube Exciters	252-261
Multi-Wire Doublet Antenna	410
Multi-Wire Transmission Lines	415
Mutual Conductance	57
Mutual Coupling, Antennas	436
Mutual Inductance	28
N	
Negative and Positive	19, 20
Negative Grid Oscillators	150
Negative Resistance	152
Neutralization:	
Circuits	160, 161, 162, 163
Grid	54, 160
Indicator	468
Plate	161
Problems	160, 164
Procedure	164
Push-Pull	162
Shunt	162
Nodal Point	176
Note	395
Noise-Balancing Systems	86-89
Noise, Internal	75
Noise-Limiting Circuits	86-89
Noise, Mixer	75
Noise Ratio	75, 77
Noise Silencers	87
Noise Suppression	86-89
Noise, Tube (Shot Effect)	75
Nomograph, Coll Calculator	510
Non-Inductive Resistor	427
Non-Resonant Line (Untuned)	406
North Pole	35
Nuclear Charge	19
Nucleus	19
Null Indicator	413, 444
O	
Ohm	21

Ohm's Law:	
A.C.	33, 38, 39
Application	21, 33
D.C.	21
Ohmmeter	470, 471
Oil-Filled Condensers	295
Open-End Stub Tuning	412
Open Lines	406
Optical Axis	154
Optimum Angle of Radiation	395
Orbital Electrons	19, 389
Orientation of Antennas	435
Oscillation:	
Frequency of	40, 62, 150
Parasitic	172
Piezoelectric	153
Triode	151, 153
Twin Peak	153
Vacuum Tube	62, 150
Oscillator-Detector Relationship	71
Oscillator-Doubler Circuits	159
Oscillator-Mixer Circuits	73
Oscillators:	
Barkhausen-Kurtz	152
Beat Frequency	86
Calibration	465
Circuits	151, 155
Code Practice	14, 469
Colpitts	151
Concentric Line	347
Crystal Controlled	153, 155 to 158
Dual Triode	156
Electron-Coupled	151
Electron Orbit	152, 389
Franklin	153
Gill-Morell	152
Harmonic	157, 158, 159
Hartley	150
Interruption Frequency	70
Keying	181
Kozanowski	152
Linear Tank	360, 364
Magnetron	152, 389
Microwave	388
Negative Grid	150, 152
Push-Pull Crystal	153
Pierce	156
Quench	70
Regenerative	157, 389
Reinartz	153
Self-Excited	150
Superregenerative	70, 359, 360, 362
Test	91
Transmitting Types	150
Triode	156
Tritet	157
Tuned-Plate Tuned-Grid	151
U.H.F.	347
Vacuum Tube	62
Wide Range Audio	473
Oscilloscope, C.R.	476
Oscilloscope Patterns	477
Overload Protection	304
Overmodulation:	
Indication	467, 476, 478
Interference	492
Nature	492
Oxide-Coated Cathode (Filament)	50, 51

P

Padder Condenser (See also—Trimmer Condenser)	93
Painting Antenna Masts	445
Paper Condenser	295
Parallel Amplifiers	59
Parallel and Push-Pull Amplifiers	59
Parallel Bandspread	79
Parallel Cathode Modulation	195
Parallel Circuits, Circulating Current	167
Parallel Circuits, Effect of L/C Ratio in	167
Parallel Condensers (Capacities)	30
Parallel Feed	177
Parallel Filaments	26
Parallel Inductances	28
Parallel Resistors	22
Parallel Resonance	41
Parallel Resonance, Circulating Current	42
Parallel Resonance in Power Supply Filters	293
Parallel Rod Amplifier—See "U.H.F. Transmitters," etc.	
Parallel Rod Oscillators—See "U.H.F. Transmitters," etc.	
Parallel Tube Circuits	59
Parasitic Elements, Antenna	435
Parasitic Suppressors	173
Parasitics (Oscillations)	172, 182
Patterns, Oscilloscopic	477
Patterns (Radiation—See "Antennas")	

Peak Current	38
Peak Inverse Voltage	294
Peak Limiters	87, 212
Peak Power	185, 199
Peak Values	38
Peak Voltage	36, 171, 294
Peak Voltmeter, Diode	462
Peaked Wave Form	166
Pentagrid Converter	55, 74
Pentode	55
Pentode Crystal Oscillator	155
Pentode, Television Amplifier	55
Percentage Modulation	186
Percentage Modulation Checker	476
Perfect Tracking	78, 93
Performance, Receiver	90, 93
Permeability	27
Phase	37
Phase Angle	38
Phase Inverter	274
Phased Antennas	428-435
Phasing Adjustment, Unidirectional Array	435
Phasing Condenser	82
Phenomena, Wave Propagation	393
Phone Test Set	467
Phone Transmitters (See—"Transmitters, Phone")	
Pi (μ), Section Antenna Coupler	417
Pi (μ) Type Filter	293
Pierce Crystal Oscillator	156
Piezoelectric Effect	153
Pipes, Concentric—See "Concentric Line"	
Placement of Coils	242
Plaque Resistors	422, 427
Plastics, Drilling	486
Plate Circuit Tuning	164
Plate Current	53
Angle of Flow	61
Plate Detection	63
Plate Dissipation	60
Plate Dissipation, Transmitting Tubes	224
Plate Efficiency	159
Plate Modulation	198
Plate Neutralization	161
Plate Resistance	57, 59
Plate and Screen Grid Modulation	201
Plate Spacing, Condenser	170
Points of Saturation	27
Polarity	36
Polarization, Radio Wave	393
Polarized Condenser	296
Poles, Antenna	445
Poles, Generator	35
Portable Equipment (See—"U.H.F." and "Mobile")	
Position of Beam Antennas	435
Positive and Negative	19, 20
Positive Peak Modulation	187
Potential Difference	21
Potential Energy	29
Powdered Iron Core	29
Power, A.C.	39
Power Actual	23
Power Amplification	60
Power Amplifiers:	
A.F.	60
R.F. (See "Transmitters, Final Amplifiers")	
Power, Apparent	39
Power, Audio	208, 471
Power, Average	186, 199
Power, D.C.	23
Power Detector	63
Power Dissipated in Resistors	23
Power Drills	485
Power Factor	38
Power Gain, Amplifier	208
Power Input Control, Transmitter	303
Power, Instantaneous	186
Power Levels	504
Power Line r.f. Filters	86
Power Measurements	471
Power Output	422, 471
Power, Peak	185, 199
Power, Radio Frequency	471
Power Ratings, Transmitting Tubes	224
Power Relation in Speech Waveforms	199
Power Supplies	291
Bias	174
Bleeder Resistors for	23, 296
Class B Modulator Voltage Regulation	290
Construction (See also "Transmitter Construction")	291
Control	247
Design	299
Filter Circuits	295
Radiotelephone (Design)	289
Rectifier Circuits—See "Power Supplies"	
Safety Switch	246
Transformer Design	305
Voltage Regulated	298
Voltage Regulation	290, 297

Power to Decibel Conversion	504
Power Transformer Design—See "Transformer Design"	
Power, Watts	23
Practice, Code	12, 14
Practice, Workshop	482
Preamplifiers (See—"Speech and Modulation Equipment")	
Preselector	69, 76, 147
Preselector, High Gain 5 Band	147
Primary	44
Primary Cell	49
Primary Keying	178
Primary Winding	44
Protection from High Voltage	242, 246
Protection, Overload	304
Protective Bias (See also—"Bias")	173, 301
Propagation of Radio Waves	393
Propagation of Ultra-High Frequencies	339
Proton	19
Pulling	74
Pulsating D.C.	37, 291
Punching Chassis	488
Push-Pull Amplifier	59, 171, 262
Push-Pull Crystal Oscillators	158
Push-Pull R.F. Circuits	262
Push-Pull Doubler	162
Push-Push Doubler	167

Q

Q	41, 77, 168
Calculation of	41
Circuit	77
Effect of Loading on	168
Relation to Circulating Current (Parallel Circuits)	42, 168
Values for Transmitter Circuits	168
Q Antennas	414
Q Bars	414
Q Matching Section	414
Q Signals	542
Quarter-Wave Antenna U.H.F.—Mobile	450
Quarter-Wave Antenna Transformer	449
Quarter-Wave Matching Stub	411-413
Quartz Crystals	163
Quasi-Optical Paths	339
Quench	70
Quench Frequency	70
Quench Oscillator	70
Quenching Action	70

R

R Meter	85
Rack Panel Construction	483
Radial Ground	402
Radian	36
Radiation	393, 395
Radiation, Angle of	394, 395
Radiation, Antenna	393, 395
Radiation, Broadside	432
Radiation, End-Fire	432
Radiation, Harmonic, vs. Q	168
Radiation, Patterns	423
Radiation Range, U.H.F.	339
Radiation, Resistance	397, 398
Radiation, Suppression of Harmonic	419
Radiator, Long Wire	424
Radiators, Vertical vs. Horizontal	399
Radio Calculations and Mathematics	502-512
Radio Frequency Amplifiers (See also—"Transmitters"):	
Class B	61
Class BC	188
Class C	61, 159, 173
For Receivers	61, 69
Grid Bias	173
Neutralization	160
Parasitics in	172
Push-Pull	171, 262
U.H.F.	348
Radio Frequency Chokes	177
Radio Frequency Current	33
Radio Frequency Inverse Feedback	211
Radio Frequency Power Measurement	471
Radio Frequency Tank Circuit Calculations	512
Radio Laws and Regulations, Amateur	513
Radio Mathematics and Calculations	502
Radio Receiver Alignment	90
Radio Receiver Construction	129
Radio Receiver Theory	66
Radio Receiver Tube Characteristics	96
Radio Service, Amateur—See "Radio Laws"—Appendix	
Radio Therapy	498
Radio Waves	393

Radio Transmitters (See—"Transmitter Construction")	
Radiotelegraph Code	12
Radiotelegraph Transmitters (See—"Transmitters")	
Radiotelephony, Power Supplies for	289
Radiotelephony Theory	184, 214
Ratings, A.F. Amplifier	505
Ratings, Rectifier	301
Ratio, Deviation	215
Ratio, Image	76
Ratio, I/C	42, 167
Ratio, Signal to Image	76
Ratio, Signal to Noise	75, 77
Ratio, VA/W	168
R/C Coupled I.F. Superheterodyne	351
R-C Filters	84
Reactance	33, 509
Capacitive	34, 67
Inductive	33, 67
Reactance-Frequency chart	508, 511
Reactance and Resistance in Combination	34
Reactance-Resistance Modulator	216
Reactance-Tube Modulator	216
Reactivation of Filaments	51
Receiver:	
Adjustment	90
Alignment	90
Amplifiers	69
Antennas	441
Bandspread in	78
Basic Components	67
Battery Operation	144
Construction	129
Coupling	69, 441
Frequency Modulation	220
Input Coupling Circuit	441
Input Resistance	77
Linear Tank Circuits	360
Preselector	69
Regenerative	67
R.f. Amplifiers	61, 69, 76
Superheterodyne	71, 345
Superregeneration	70, 345
Test Instruments	90, 472-478
Theory	66, 345
Tracking	78, 93
Tubes, Characteristics of	95
Tubes, Discussion	66
U.H.F.	345, 350
Receivers:	
224 Mc. Superregenerative Receiver	360
Advanced Superheterodyne	138
and Transceivers, U.H.F.	350
Antennas for	441
Battery Converter	144
Battery Powered 112 Mc. Transceiver	364
Converter, 56 Mc.,	350
Economic Five-Tube Superheterodyne	134
F.M.—A.M. 112 Mc. Superheterodyne	359
High-Frequency Converters	350
High-Gain 5-band Preselector	147
Microwave See "U.H.F."	
Mobile, 112 Mc. Superregenerative	362
Simple Two-Tube Autodyne	129
Simple Three-Tube Superheterodyne	132
Superheterodyne	71, 345, 353, 359
Superregenerative	70, 345
U.H.F.	345, 350, 360
U.H.F., Superhet, R/C Coupled I.F.	351
Rectification	291
Rectification Efficiency	63, 64
Rectified A.c.	37
Rectifier	62, 291
Rectifier and Filter Circuit Considerations	294
Rectifier, Bridge Type	294, 299, 301
Rectifier Circuits	299
Rectifier, Diode Feedback	212
Rectifier-Filter System	292
Rectifier, Full Wave	62, 291, 299
Rectifier-Grid Controlled	179
Rectifier, Half Wave	62, 291, 299
Rectifier, High Vacuum	294
Rectifier, Mercury Vapor (See also—"Tubes")	63, 301
Rectifier Rating (Discussion)	301
Rectifier, Three-Phase, Full Wave	300
Rectifier Tubes (for High Power Service)	See Chapter Ten
Reduction Gears, Antenna Rotation	439
Reflected Impedance (resistance)	45
Reflection of Radio Waves	393
Refraction of Radio Waves	393
Regeneration:	
Cathode	165
Methods	68
Regenerative Crystal Oscillator	157, 389
Regenerative Detector	67, 68
Regenerative Doubler	165
Regenerative Oscillators, U.H.F.	389

Regenerative Preselector	76	Second Detectors	84
Regenerative R.F. Amplifier	70	Second Detector Noise Limiters	89
Regulation, Power Supply	297	Secondary Cell	49
Regulations, U.S. Amateur	513	Secondary Emission	55
Reinartz Oscillator	158	Secondary Winding	44
Rejection Control	82	Selective Fading	394
Rejection, Noise	86-89	Selectivity	41, 42, 72
Rectivity, Effect of L/C Ratio (Parallel Circuits)	42	Selectivity Curve	41
Rejuvenation of Filaments	51	Selectivity, Effect of L/C Ratio (Parallel Circuits)	42
Relay-Rack Construction	483	Self-Bias (see—"Bias")	
Reluctance	27	Self-Excited Oscillator	150
Resistance and Reactance in Combination	34	Self-Inductance	28
Resistance	20	Self-Synchronous (Selsyn) Motors	439
Resistance, Effective	22	Self-Quenching	70
Resistance, Input	77	Selsyn Motors	439
Resistance, Radiation	397, 398	Semi-Flexible Transmission Line	408
Resistances:		Semi-Resonant Transmission Lines	406
Bleeder	23, 295	Sensitivity	67
Equations	21	Separate Bias Supply	174, 301
Ground	399	Series Bandspread	80
Molecular Theory of	20	Series Cathode Modulation	195
Parallel	22	Series Circuits	39
Plate	57, 59	Series Condensers	31
Radiation	397, 398	Series Crystal Filter	82
Radio-Frequency	41	Series Feed	177
Series	22	Series Filament Operation	26
Series-Parallel	23	Series Inductances	28
Unit of	21	Series Loading Coil	403, 440
Voltage Dividers	24	Series Modulation	203
Wattage	23	Series Parallel Condensers	31, 32
Resistive Coupling	60	Series Parallel Resistance	22
Resistors	22	Series Resistance	40
Resistors, Bleeder	23, 296	Series Resonance	40
Resistors for Series Filament Operation	26	Series Resonant Circuits	292
Resistors, Non-Inductive	427	Series Resonant Filter	78
Resistors, Plaque	422, 427	Series System Bandspread	93
Resistors, Terminating for Rhombic (Diamond)	427	Series Tracking Condensers	93
Antenna	427	Service, Amateur See "Radio Laws"—Appendix	
Resistors, Vacuum Sealed	471	Set Noise	75
Resistors, Voltage Equalizing	32	Sharpness of Resonance	41
Resonance:		Sheet metal working	483, 488
Antenna	397, 398	Shield, Electrostatic	47, 420, 442
Cavity	341	Shield, Faraday	47, 420, 442
Curve	41, 47	Shielding	47, 289
Formula	40	Short Line Tuning (U.H.F.)	343
Harmonic	397	Short Skip	340, 394
Of Inductance	40, 508	Shorted Stub Tuning	412
Parallel	41	Shot Effect	75
Series	40	Shunt Feed	61, 177
Sharpness of	41	Sidebands	185
Resonant Circuit Impedance	42	Signal Generator	472
Resonant Circuits	39, 67	Signal Image Ratio	76
Resonant Filter	292	Signal Noise Ratio	75, 77
Resonant Frequency	39	Signal Skip See "Skip"	
Resonant Line (Tuned)	405	Signal Strength Meters	85, 457-460
Resonant Line Circuits (See "Antennas, Receivers" and "U.H.F.")		Silencers, Noise	86-89
Resonant Tank Current	42	Simple 15-Watt Exciter	249
Resonant Trap Circuit	293	Simple Universal Coupler, Antenna	421
Resonator, Crystal	82, 153	Simple V.T. Voltmeter	459, 462
R.F. Amplifier (See also—"Radio Frequency Amplifiers")	61, 69, 76, 159, 348	Simplified A.M.C.	285
R.f. Auto Transformer	45, 46	Sine	36
R.f. Choke	177	Sine Wave	36
R.f. Coupling Systems (See listings under Capacitive, Inductive, etc.)		Single-Ended Amplifiers, r.f.	269
R.f. Inverse Feedback	211	Single-Ended Tubes	56
R.f. Power Measuring Device	471	Single-Frequency Tuned Circuits	77
Rhombic Antenna	426	Single-Phase Full-Wave Rectifier	292
Ribbon Microphone	206	Single-Section Filter	292, 293
Ripple	292	Single Signal Effect	82
Ripple Voltage	292, 293	Single-Wire Transmission Line	410
R.m.s.	37, 294	Skin Effect	41
Root Mean Square Value	37, 294	Skip Distance	339, 394
Rotatable Antennas	436	Skip, Long	340, 394
Rotating Mechanisms	439	Skip, Short	340, 394
		Sky Wave	339, 393
		Slack, Guy Wire	445
		Smith X-H Array	431
		Smoothing Choke	295, 312
		Socket Connections, "Receiving Tubes"	116
		Socket Connections, "Transmitting Tubes"	225
		Socket Holes, Punching	488
		Soldering	489
		Soldering Irons	484
		Sound Waves	184
		South Pole	35
		Space Charge Effect	52, 55
		Spacing, Condenser Plate	170
		Spacing, Rotatable Antenna Element	436
		Special Framework, Transmitter	483
		Special Purpose Vacuum Tubes	56, 114
		Speech Amplifiers (See also—"Modulators")	207
		Speech Equipment	204, 271
		Speech and Modulation Equipment	271
		Speech Waveforms	199
		Splatter Suppressor	288
		Spray-Shield Tubes	495
		Spreaders, Feeder	405
		Spurious Emissions	494
		Stability, Crystal	153
		Stability, Receiver	72

S

Stability, Transmitter:	
Crystal	153
E. C. Oscillator	152
Oscillator	151, 152
Stacked Dipole Antenna	428
Standard Push-Pull Amplifier	262
Standing Wave Detector	413
Standing Waves	395
Starting Voltage, Rectifier	62, 297
Static Characteristics	53
Static Charge	29
Station, Amateur—Defined—See "Radio Laws"—	
Appendix	
Station Arrangement (Photographs)	8, 9, 10
Station Control System	246, 247
Station License	8
Steel Core Wire	445
Steel Drilling	485
Sterba Array	432
Storage Batteries	49
Storage of Electrical Energy	21, 29
Stray Capacity	80
Stray Pickup, Receiver	441, 494
Stress, Dielectric	30
Stubs, Matching	411
Study, for License	11
Sun, Effect on Ionosphere	393
Superheterodyne Alignment	90
Superheterodyne Interference	496
Superheterodyne Receivers (See also—"Receivers")	71
Superheterodyne Theory	71
Superheterodyne Tracking	78, 90
Superregeneration	70
Superregenerative Receiver	70
Supply, A. C. Mains	245
Supply, Bias	174, 301
Supply, Power—See "Power Supplies"	
Supporting the Antenna	445
Suppression, Bass	201
Suppression, Harmonic	419
Suppression, Noise	86-89
Suppressor Grid	55
Suppressor Grid Modulation	191
Suppressor, Parasitic	173
Suppressor, Splatter	288
Surface Wave	393
Surge Impedance	405
Sweep Circuit	479
Swinging Choke	295, 312
Switching, Condenser	80
Switching, Control System	247
Switching, Meter	242
Symbols, Radio—See "Appendix"	
Synchronous Motors, Antenna Rotation	439
Systems, Amplitude Modulation	187
Systems,*Noise Reduction	86-89

T

Tables (See: "Charts")	
Tank Circuit	41, 42
Tank Circuit Capacities	167
Tank Circuit Considerations, Crystal Oscillator	
.....	153 to 158
Tank Circuit Flywheel Effect	43
Tank Circuits, Linear	360
Tank Current	42
Tapped Circuits	80
Tapped Inductances	80, 161
Telephone Poles, Antenna Support	445
Television Amplifier Pentodes	56
Temperature Coefficient, Crystal	153
Temperature Inversion	339
Terman-Woodyard Amplifier	198, 203
Terminating Resistor Rhombic (Diamond)	
Antenna	427
Termination, Transmission Line	427
Test and Measuring Equipment	452
Test Instruments for Receivers	90
Test Oscillator	91
Test Set, Phone	467
Testing, Receiver	93
Tetrode	54
Theory, Fundamental Radio and Electrical	20
Amplifier	56
Atomic	19
Antenna Radiation	393, 395
Conduction	20, 48
Crystal Filter	82
Demodulation	66
Detector	66
Electronic Emission	50
Filaments	50
Filters	292
Frequency Multipliers	165
Frequency Modulation	214
Heaviside-Kennelly Layer (Ionosphere)	393
Inverse Feedback	210

Ionization	48, 393
Ionosphere	393
Microphone	204
Modulation	184
Neutralization	160
Noise Reduction Systems	86
Oscillators	62, 153
Polarization, Radio Wave	393
Piezoelectric Oscillation	153
Radiotelephony	184
Receiver	66, 345
Rectifier	62, 291
Regenerative Detector	67
Superheterodyne	71, 345
Superregenerative Detector	70, 345
Transmitter	150, 346
U.H.F. Communication	339
Unidirectional Radiation	433, 436
Vacuum Tube	50
Wave Propagation	393
Therapy, Radio	498
Thermal Agitation	75
Thermal Noise	75
Thermionic Emission	50
Thoriated-Tungsten Filament	50
Three-Phase Full-Wave Rectifier	300
Three-Phase Half-Wave Rectifier	299
Thump Filters	178
Tickler Coil	68
Tool Hints	484
Tools	483
Tools, Receiver Alignment	91
Torque, Rotating	439
Tourmaline Crystals	153
TPTG Circuit	151
Tracking	78, 93
Transceivers	350, 362, 364
Transconductance	57, 65
Transconductance (Converter)	65
Transformer	44
Transformer Action	44, 45
Transformer, Antenna Matching	414
Transformer, Auto	45, 46
Transformer Coupling	45, 46, 60, 190
Transformer Cutouts	488
Transformer Design and Construction	305
Transformer, i.f.	81
Transformer, Impedance	43, 45
Transformer, Insulation	311
Transformer, Modulation Calculations	200
Transformer, r.f.	44, 46
Transitron	152
Transmission Lines	341, 403
Transmission Line Circuits, U.H.F. Equipment	341
Transmission Line Modulator	218
Transmission Speed, Radio Waves	393, 396
Transmission Range, U.H.F.	339
Transmitter Adjustment	248
Transmitter Circuit Q	167 to 170
Transmitter Construction	313
Transmitter Coupling to Antenna	416-422, 442
Transmitter Design	240
Transmitter Ground	246
Transmitter Power Input Control	247
Transmitter Power Output, Measurement	422, 471
Transmitter Theory	150, 346
Transmitter Wiring	242
Transmitters:	
Adjustments	248
Antenna Coupling	416-422, 442
Bandswitching	256
Bias Supplies	173, 301
Bias Supply Considerations	173, 302
Cathode Bias	174
Chokes, R.f.	177
Complete:	
HY69, 40 Watt	313
35T, 100 Watt Cathode Mod. Phone	322
813, 250 Watt C.W. Transmitter	325
400 Watt Plate Mod. Phone	332
Components	242
Condenser	167, 170, 242
Construction	313
Control, Power Input	247
Crystals, Control	153
Crystals, Mounting	154
Dummy Antennas for	422
Efficiency, Amplifier	160
Excitation	165, 241
Exciters	241, 313
Final Amplifiers (See also—"Transmitter Construction")	
"Accordion Coll"	256
Bandswitching	256
Class B	159, 197
Class C	159
Construction	262-270
Loading	164
Neutralization	160, 164

One-kilowatt	266
Parallel	177
Parallel Rod, U.H.F.	368-392
Plate Circuit Tuning	164
Power Input Control	303
Push-Pull	177, 262
Push-Pull TW150	266
Push-Pull 35TG	265
Push-Pull 812, with Modulator	317
Push-Pull HK254	267
Single-Ended	268, 269
Forty-Watt HY69	313
Frequency Modulation	380 to 388
Frequency Multipliers	165
Frequency Stability	151, 152, 153
Grid Neutralization	54, 160
Grid Bias	173
Grounds	246, 400-402
Harmonic Generation	165, 454
Harmonic Suppression	419
Hartley Circuit	150
Interstage Coupling	175
Keying	178
L-C Ratios	42, 167
Link Coupling	176
Load Impedance	292
Metering	243
Microwave	388
Mobile U.H.F.	368-392
M.O.P.A.	368
Neutralizing	160, 164
Oscillator Circuits	150
Oscillator Keying	181
Parallel Feed	177
Parallel Operation	177
Parasitic Oscillations	172
Pentode Crystal Oscillators	155
Plate Neutralization	160
Portable	368-392
Power Amplifiers	159
Power Input Control	303
Power Output Measurement	422, 471
Power Supplies	291
Push-Pull Operation	171, 177
Push-Push Doublers	167
R.F. Chokes	177
Safety Switch	247
Screen Grid Amplifiers	160, 172, 256
Self-Controlled Oscillator Circuits	150
Series Feed	177
Standard Push-Pull Amplifier	262
Tank Circuits	167
Tetrode Crystal Oscillators	155
Tube Tables, Manufacturers	56
Tube Tables of Characteristics for Transmitting	224
Tube Tables (Transmitting Type) Cross Index by Plate	224
Dissipation	297
Tubes, Voltage Regulator	436
Tubing, Metal, as Antenna Elements	151
Tuned-Plate Tuned-Grid Oscillator	158, 164, 190
Tuning	346, 350, 368
Ultra-High Frequency	242
Wiring	224
Transmitting Tubes	221
Travis Discriminator	445
Trees, Antenna Supports	93
Trimmer Condenser	50, 53
Triode	156
Triode Crystal Oscillators	67
Triode Detector	74
Triode-Heptode	74
Triode-Hexode	153
Triplers (see "Frequency Multipliers")	93, 288
Tritet Oscillator	75
Trouble Shooting	50
Tube Noise	95
Tubes, Vacuum (See also—"Vacuum Tubes")	56
Discussion of Receiver Types	241
Dual	177
for Exciters and Transmitters	66, 95
Parallel and Push-Pull	62
Receiving	50
Rectifiers (See also—"Tube Tables")	224
Theory	39, 41
Transmitting	405
Tuned Circuits	405
Tuned Doublet	90
Tuned Feeders	347
Tuned R. F. Receiver Alignment	50
Tuned Transmission Line	67
Tungsten Filament	78
Tuning	167
Tuning Arrangements and Bandspreading	153, 154, 158
Tuning Capacities	85
Tuning Crystal Oscillators	85
Tuning Eye	85
Tuning Indicators	412
Tuning Open Stubs	343
Tuning Short Lines	307
Turns Calculation, Transformer	43, 45
Turns Ratio	43
Turns-Voltage Ratio	153
Twin Peaks	407
Twisted-Pair Feeders (EO1)	293
Two-Section Filter	405
Two-Wire Doublet Antenna	406
Two-Wire Open Line	295
Types of Filter Condensers	50
Types of Emitters	52
Types of Vacuum Tubes	

U	
U.H.F. Communication	339
Ultra-High Frequencies	
Antenna Systems	447
Centimeter Waves	349
Concentric-Line Oscillator Circuit	347
Converters, U.H.F. Frequency (See also—"Receivers")	350
Crystal Control	376
Direct Communication	339
Direction Finders	451
DX	340
Equipment Considerations	341
Filament Circuit	349
Frequency Measurement	344
Frequency Modulation Transmitters	380 to 388
Lecher Frame	345
Lecher Wire Systems	344
Linear Oscillator Circuits	341
Long Skip	341
Microwaves	349
Microwave Transmitters	388 to 391
Mobile Antennas	450
Mobile Receivers—See "U.H.F. Receivers"	
Mobile Transmitters—See "U.H.F. Transmitters"	
Modulators (See—"U.H.F. Transmitters" and "Main Index Item, "Modulators"")	
M.O.A.P. Transmitters	368
Open-Line Circuits	344
Oscillators	368
Oscillator Circuits	347
Propagation	339
Push-Pull Beam Tubes	369
Receivers:	
Battery Powered 112 Mc. Transceiver	364
A.M.-F.M. 112 Mc. Superhet	353
Microwave	349
Mobile, 112 Mc. Transceiver	362
R/C Coupled I.F. Superheterodyne	351
R/C Superheterodyne	351
56 Mc. Converter	350
Superheterodyne	345, 351, 353
Superregenerative	345, 359, 360
Theory	345
112 Mc. Superregenerative	359
224 Mc. Superregenerative	360
Transceiver	362, 364
Receivers and Transceivers	350
Resonant-Line Construction	405
R.F. Amplifiers	348
Self-Quenched Receivers	70
Short Skip	340
Superheterodyne Receivers	345, 351, 353
Superregenerative Receivers	344, 359, 360
Therapy Machine	498
Transceivers	362, 364
Transmission Line Circuits	341
Transmission Range	339
Transmitters:	
Amplifier Hints	348
Crystal-Controlled	376 to 380
Frequency Modulation	380 to 388
General	346, 368
HY-75, 224 Mc., 8 Watt Oscillator	373
Microwave	388
M.O.P.A.	368, 374
Mobile	368-392
Push-Pull HY-75 Oscillator	373
Theory	346
Transceivers	362, 364
2-Watt, 224 Mc., 7A4 Oscillator	372
8-Watt Oscillator and Modulator	369
20-Watt HY-75 Oscillator, 112 Mc.	369
50-Watt M.O.P.A. Transmitter	374
100-Watt Resonant Line 112 Mc. Oscillator	370
Wavemeters: See—"Lecher Wires" and "Frequency Measurement"	
Unidirectional Array	433, 436
Units, Electrical	21
Unity Coupling	47
Universal A.M.C.	286
Universal Antenna Coupler	421
Untuned Transmission Lines	406
Use of Amateur Stations—See "Radio Laws"—Appendix	

V

V Antenna	425
V-Cut Crystals	153
Vacuum Tube:	
Amplifier	56
Amplification Factor (μ)	57
Application	56
Detectors	63
Inductive Output Amplifier (825)	349, 392
Operation	50
Oscillator	62, 150
Reactivation	51
Rectifier	62
Theory	50
Vacuum Tube Keying	182
Vacuum Tube Operation:	
As Amplifier	56
Class A	57
Class AB	58
Class B	58, 61
Class C	61
Other Classifications	62
As Detectors	63
As Measuring Device	65
As Oscillator	62, 150
As Rectifier	62
Vacuum Tube Theory	50
Vacuum Tube Voltmeters	459
Vacuum Tubes:	
Beam Tubes	55, 269
Cathodes	50
Cathode Ray	128
Converters	55
Diode	52
Discussion of Receiver Type	66
for A.M.C.	286
for Grid Modulation	190
for U.H.F.	369
Glow Discharge	297
Heptode	56
Keying	181
Mixer Tubes	56
Mutual Conductance	57
Pentagrid Converters	55
Pentode	55
Plate Dissipation	60, 224
Plate Resistance	57, 59
Ratings and Characteristics, Receiving Types	95-128
Ratings and Characteristics, Transmitting Types	224-239
Receiving	66, 95
Rectifiers	62, 301
Screen Grid	54
Single-Ended Types	56
Socket Connections:	
Receiving Tubes	116
Transmitting Tubes	225
Space Charge	52, 55
Special Types	114, 297
Tables:	
Cathode Ray	128
Receiving	96
Rectifiers (See Receiving or Transmitting Tube Tables)	
Socket Connections	116, 225
Transmitting	224
Television Amplifier Types (See also "Receiving Types")	55
Tetrode	54
Transconductance	57
Transmitting	55
Triode	50
Types	52
Voltage Regulator	297
Vacuum Type Condenser	267
Vacuum Type Resistor	471
Valve (Action of Vacuum Tube)	54
Variable Condenser, Transmitter	242
Variable Efficiency Modulation	187
Variable Frequency Oscillator	152, 252
Variable Selectivity	82
Variation of Ionosphere Height	394
VA/W Ratio	168
Velocity, Angular	37
Velocity Microphone	206
Velocity of Radio Waves	393
Vertical Angle vs. Horizontal Pattern, Antenna	423
Vertical Polarization	393
Vertical vs. Horizontal Antennas	399
V.f.o. Exciter	252
Vibration, Axial	153
Vibration, Piezoelectric	153
Volt, Definition	21
Voltammeter	470
Voltage, Across Coil and Condenser	41
Voltage Amplification	60, 507
Voltage Amplifier	60, 507
Voltage, A.V.C.	84

Voltage, Bias	53, 174, 301
Voltage, Bias Supply	174, 301
Voltage, Breakdown (Of Mercury Vapor)	63
Voltage Control, Transmitter	303
Voltage, Cutoff Bias	53, 58, 61, 174
Voltage-Decibel Ratio	507
Voltage Dividers	24
Voltage Drop	21, 24
Voltage Feed	403
Voltage, Induced	28, 43
Voltage, Input	509
Voltage, Inverse Peak	294
Voltage Loops	395
Voltage Nodes	395
Voltage, Peak	37, 294
Voltage Equalizing Resistors	32
Voltage Rating of Series Condensers	32
Voltage Regulation for Class-B Modulator	290
Voltage Regulator Tubes	297
Voltage, Ripple	293
Voltage, R.M.S.	294
Voltage in Series Resonant Circuit	40
Voltage-Turns Ratio	43
Voltage, Working (D.C.)	30, 295
Voltmeter	470
Voltmeter, A.C. Ripple	293
Voltmeter, Vacuum Tube	459, 462
Voltammeter	470
Volume Compressor (Automatic Peak Limiters)	212
Volume Control, Automatic	84
Volume Control, Floating (Interference Relationship)	494
V.T. Voltmeter	459, 462

W

W8JK Rotary Array	438
Water Pipe Ground	402
Watt	23
Watt-Decibel Chart	504, 506
Wave Propagation	393
Wave Propagation, U.H.F.	339
Wave, Sine	36
Wave, Speed of Radio	393, 396
Wave Traps	491
Waveform:	
Class A	58
Class B	59
Class C	61, 168
Peaked	166
Power Relations in	199
Rectifier	37
Sine	36
Speech	199
Waveform Distortion	167
Waveform, Peaked	166
Wavelength	395, 396
Wavelength Determination	40, 452, 463
Wavelength-Frequency Conversion	397
Wavemeters	452
Wavemeters, U.H.F. (See also: "Lecher Wires")	452
Waves, Standing	395
Wave Trap	492
Wet Electrolytic Condensers	295
Wide Range Audio Oscillator	473
Wind, Guying Against	445
Wind, Torque Developed by	445
Winding, Transformer	308
Wire, Antenna	446
Wire, Copperweld	446
Wire, Guy	445
Wire Tables	306, 308
Wiring Transmitter	242
Wood Saw	485
Working Voltage	30, 295
Workshop Practice	482

X

X Axis	153
X-Cut Crystals	153
X-H Array	431

Y

Y Axis	153
Y-Cut Crystals	153
Y-Matched Impedance Antenna	409

Z

Z Axis	153
Zepp Antenna	403
Zepp Feeders	403
Zero Beat	68, 455
Zinc Alloy Drilling	486
Zone of Silence (Skip Distance)	339, 394

Index to Advertisers

The following advertisers are recommended to our readers. Their products and services are nationally known and respected. Similar books in other technical fields sell for \$5.00 upwards—mostly upwards. Whatever value this book may have for you above its purchase price is a gift to you from these advertisers, who have made such a policy possible. We suggest that you patronize them when purchasing parts for construction of equipment shown in this book.

Barker & Williamson.....	572	Polk & Co., R. L.	584
Bliley Electric Co.	536, 537	RADIO, The Editors of:	
Bud Radio, Inc.	577	RADIO	585
Burgess Battery Co.	575	Radio Binder	588
Candler System Co.	576	Radio Catalog	592
Cardwell Mfg. Co., The Allen D.	578	Editors of RADIO	591
Centralab	567	RADIO Amateur Newcomer's	
Cornell-Dubilier Electric Corp.	528, 529	Handbook	586
Eitel-McCullough, Inc.	539	RADIO Noise Reduction Handbook....	591
Frank Dickman	583	RADIO WAZ Map.....	590
General Electric	520, 521	RCA Mfg. Co., Inc.	516, 517, 553
Hallierafters, Inc., The.....	546, 547	Radio Mfg. Engineers, Inc.	565
Hammarlund Mfg. Co., Inc.	559	Radiocrafters, The	586
Heintz & Kaufman, Ltd.	555	Solar Mfg. Corp.	543
Henry Radio Shop.....	580	Sprague Products Co.	557
Hytronic Laboratories	541	Sprayberry Academy of Radio.....	568
Johnson Co., E. F.	532, 533	Standard Electrical Products Co.	582
Kenyon Transformer Co., Inc.	563	Standard Transformer Corp.	579
Lafayette Radio Co.	573	Struthers Dunn, Inc.	581
Mallory & Co., Inc., P. R.	569	Sun Radio Co.	570
Meissner Mfg. Co.	571	Taylor Tubes, Inc.	561
McElroy, T. R.	550, 551	Thordarson Elec. Mfg. Co.	574
Ohmite Mfg. Co.	524, 525	United Catalog Publishers, Inc.	589
Par-Metal Products Corp.	587	Universal Microphone Co., Inc.	588